

MANATEE COUNTY, FLORIDA

57TH AVE. SIDEWALK FROM US 41 TO 26TH ST. W.

MANATEE COUNTY, FL

9012180

October 28, 2013

57TH AVE. SIDEWALK FROM
 US 41 TO 26TH ST.W.
 MANATEE COUNTY, FL
 COVER SHEET



VICINITY MAP
N.T.S.

PROJECT SITE

RELATED STANDARDS AND SPECIFICATIONS

GOVERNING STANDARDS AND SPECIFICATIONS:
 FLORIDA DEPARTMENT OF TRANSPORTATION 2013 DESIGN STANDARDS AND REVISED INDEX DRAWINGS, AS APPENDED HEREIN, AND APPLICABLE ARTICLES AND SUBARTICLES OF DIVISION I AND ALL OF DIVISIONS II & III OF THE 2013 STANDARD SPECIFICATIONS FOR ROAD AND BRIDGE CONSTRUCTION, AS AMENDED BY CONTRACT DOCUMENTS.

FOR DESIGN STANDARDS CLICK ON THE "DESIGN STANDARDS" LINK AT THE FOLLOWING WEB SITE:
[HTTP://WWW.DOT.STATE.FL.US/RDDDESIGN/](http://www.dot.state.fl.us/RDDDESIGN/)

FOR THE STANDARD SPECIFICATIONS FOR ROAD AND BRIDGE CONSTRUCTION CLICK ON THE "SPECIFICATIONS" LINK AT THE FOLLOWING WEB SITE:
[HTTP://WWW.DOT.STATE.FL.US/SPECIFICATIONSOFFICE/](http://www.dot.state.fl.us/SPECIFICATIONSOFFICE/)

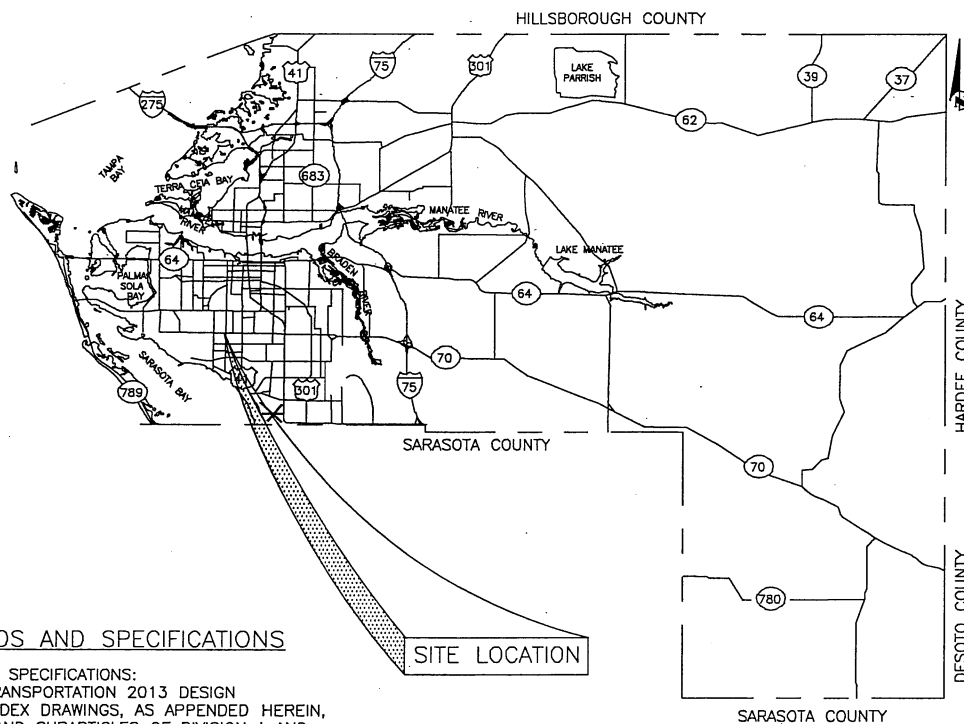

SITE LOCATION

FINAL PLANS

NO.	INDEX OF SHEETS
1	COVER SHEET
2-3	GENERAL NOTES & LEGEND (2)
4	PROJECT LAYOUT
5	TYPICAL SECTION
6-14	PLAN & PROFILE (9)
15	DRAINAGE CROSS SECTION
16	PEDESTRIAN BRIDGE DETAILS
17	PEDESTRIAN BRIDGE FOUNDATION

SHOP DRAWINGS
TO BE SUBMITTED TO :

JOHN SEALS, P.E.
 KING ENGINEERING ASSOC, INC.
 4921 MEMORIAL CENTER, SUITE 300
 TAMPA, FLORIDA 33634
 PHONE: 813 880 8881
 FAX: 813 880 8882

PLANS PREPARED BY:



4921 Memorial Highway
 One Memorial Center, Suite 300
 Tampa, Florida 33634
 Phone 813 880-8881
 Fax 813 880-8882
www.kingengineering.com
 Engineering License #2610

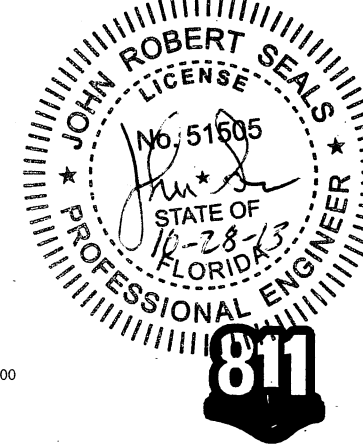

Know what's below
 Call before you dig

NO.	REVISION DESCRIPTION	BY	DATE

PROJECT #	9012180
SURVEY #	000
SEC./TWN./RGE	----
SCALE	1"=40'
SURVEYED	----
DESIGNED	CKH 08/27/13
DRAWN	CKH 08/27/13
CHECKED	JRS 08/27/13

JOHN SEALS, P.E.
 FLORIDA P.E. # 51505

Signature & Date

SHEET 1

I:\P\c\m\B281\000\000\cadd\cadd\KEYS8001.dwg, KEYS8001, 10/28/2013 4:20 PM, Colin K. Harde, 1:2,549, ANSI A (8.50 x 11.00 inches)

D:\VPW-Civil\5881\000\000\Cadd\5881\Plan\10\21/2013 11:21 AM Calvin K. Hardee, I.T. AISE D (22.00 x 34.00 inches)

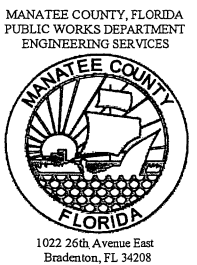
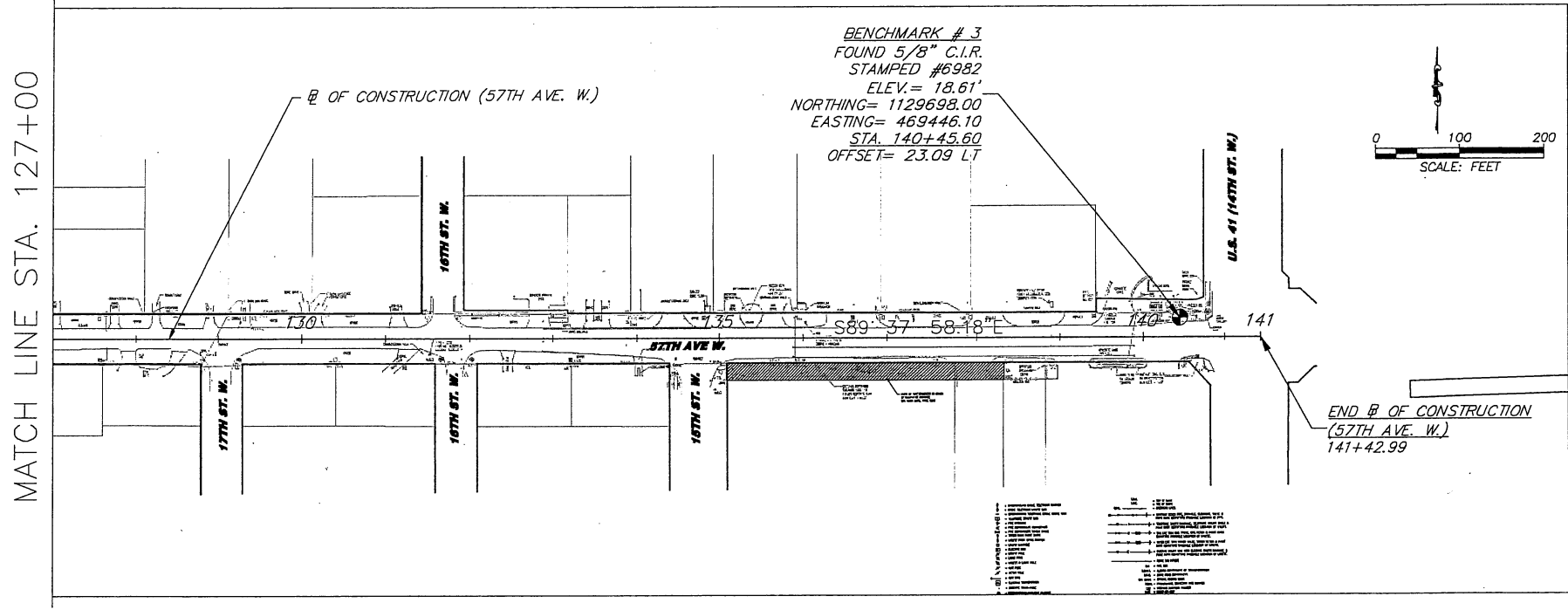
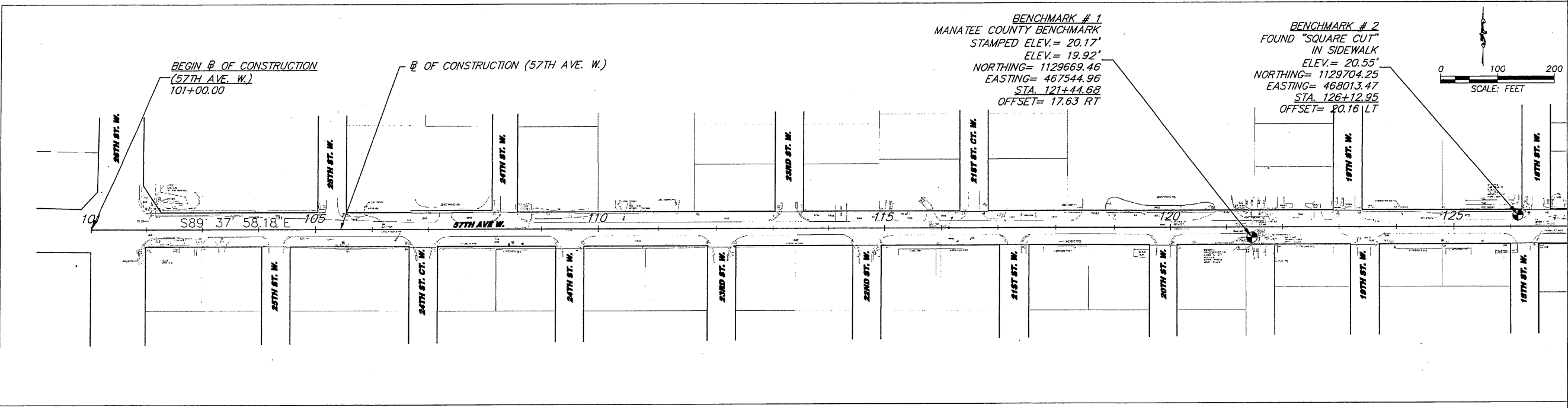

57TH AVE. SIDEWALK FROM US 41 TO 26TH ST.W. MANATEE COUNTY, FL PROJECT LAYOUT

NO.	REVISION DESCRIPTION	BY	DATE

PROJECT #	9012180
SURVEY #	000
SEC./TWN./RGE	----
SCALE	1"=40'
SURVEYED	----
DESIGNED	CKH 08/27/13
DRAWN	CKH 08/27/13
CHECKED	JRS 08/27/13

JOHN ROBERT SEALS
LICENSE SEALS
No. 51505
STATE OF FLORIDA
PROFESSIONAL ENGINEER

JOHN SEALS, P.E.
FLORIDA P.E. # 51505
Signature & Date
SHEET 4

D:\PW-CAD\B2B1\000\000\000\CADD\05\TYPICAL SECTION_10/24/2013 11:21 AM C:\win.k. hards. 11. ANSI D (22.00 x 34.00 inches)

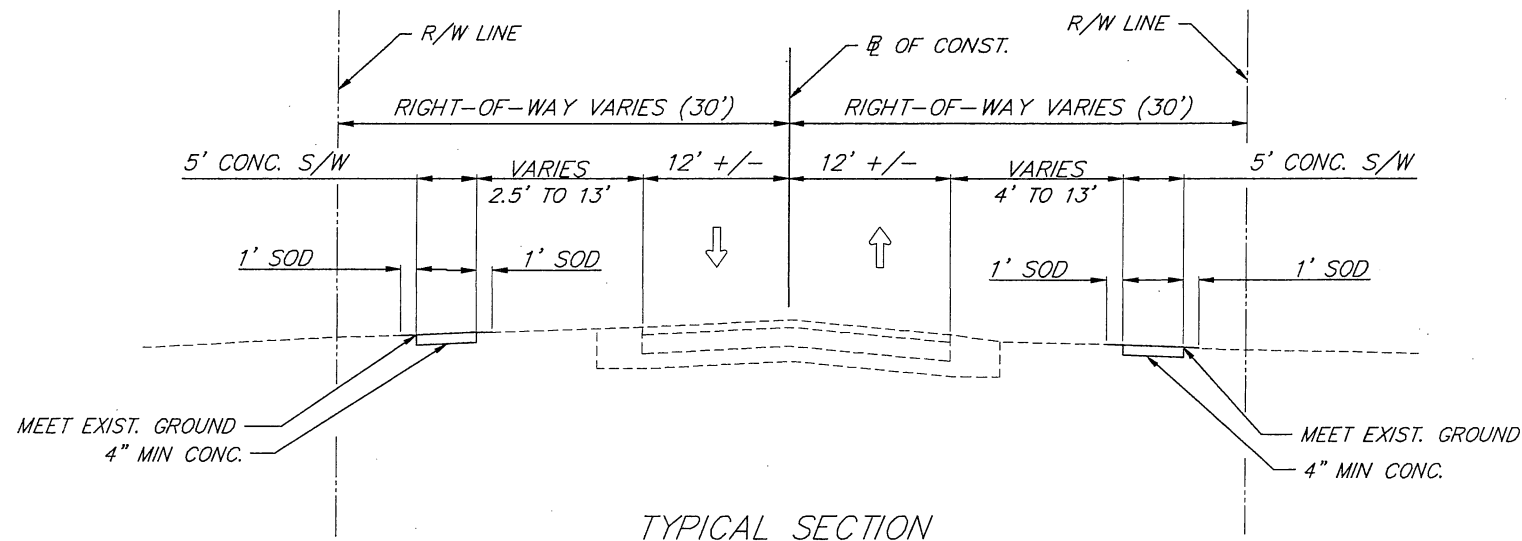

TYPICAL SECTION
N.T.S.
57TH AVE W. SIDEWALK
FROM US 41 (14TH ST. W.) TO 26TH ST. W.

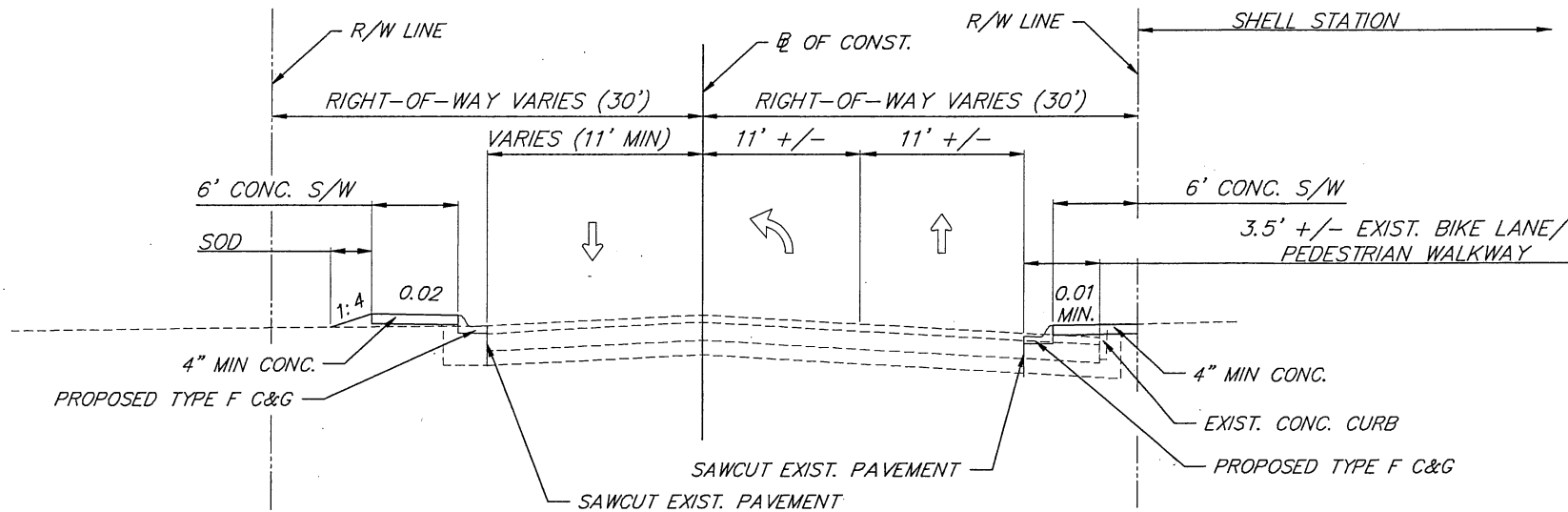

TYPICAL SECTION
N.T.S.
57TH AVE W. SIDEWALK
NEAR US 41 (14TH ST. W.)

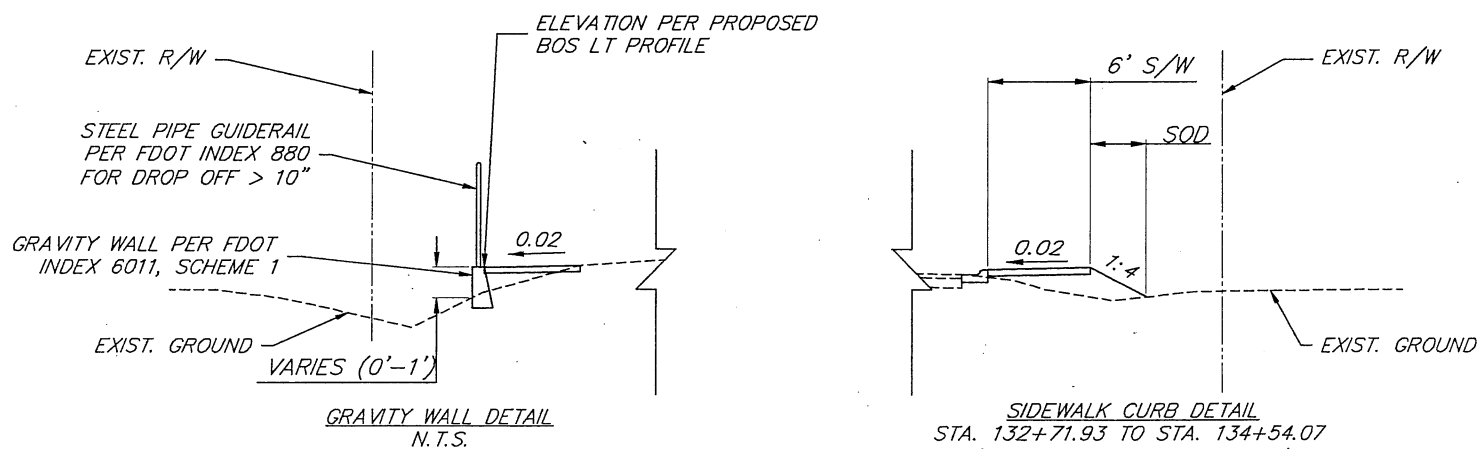

GRAVITY WALL DETAIL
N.T.S.

SIDEWALK CURB DETAIL
STA. 132+71.93 TO STA. 134+54.07
(EXCEPT FOR CLOSED FLUME)
N.T.S.

POSTED SPEEDS:
57TH AVE W. 35 MPH
26 ST. W. 40 MPH
US 41 (14TH ST. W.) 45 MPH
SIDE STREETS 30 MPH

LAYER COEFFICIENTS:
0.44 TYPE FC-9.5 FRICTION COURSE
0.44 TYPE SP-9.5 STRUCTURAL COURSE

EXISTING PAVEMENT REHABILITATION DRIVEWAY REHABILITATION:
MILL 1" AVERAGE DEPTH EXIST. ASPHALT PAVEMENT
1" TYPE SP-9.5 ASPHALT CONCRETE (TRAFFIC B) STRUCTURAL COURSE (OR MANATEE COUNTY APPROVED EQUIVALENT)

NOTES:
SIDEWALKS SHALL BE CONSTRUCTED IN ACCORDANCE TO THE FOLLOWING MANATEE COUNTY HIGHWAY TRAFFIC AND STORMWATER STANDARDS SECTION 300:
<http://www.mymanatee.org/home/government/departments/public-works/engineering-services/engineering-standards.html>

- SIDEWALK SHALL BE CONSTRUCTED A MINIMUM OF 4" THICK, USING 3000 PSI CONCRETE. WHERE SIDEWALK BISECTS A DRIVEWAY, THE MINIMUM SHALL BE 6" OF CLASS I CONCRETE. *SEE SHEETS #101.2 AND 101.3
- ALL SIDEWALKS SHALL BE CONSTRUCTED TO THE SPECIFICATIONS OF THE MANATEE COUNTY LAND DEVELOPMENT CODE, SECTION 722. A MINIMUM (5) FOOT WIDE SIDEWALK SHALL BE INSTALLED ALONG THE NORTH AND WEST SIDES OF ALL NEW LOCAL STREETS WHICH ARE CONSTRUCTED IN CONJUNCTION WITH A NEW RESIDENTIAL DEVELOPMENT. A SIDEWALK A MINIMUM OF (5) FEET IN WIDTH SHALL BE INSTALLED ON BOTH SIDES OF ALL THOROUGHFARES. REFER TO FDOT ROADWAY AND TRAFFIC STANDARDS, LATEST REVISION FOR CURB CUT RAMP SPECIFICATIONS.
- THE CONCRETE SHALL BE GIVEN A BROOM FINISH. THE SURFACE VARIATIONS SHALL NOT BE MORE THAN 1/4" UNDER A TEN FOOT STRAIGHTEDGE, NOR MORE THAN 1/8" ON A FIVE-FOOT TRAVERSE SECTION. THE EDGE OF THE SIDEWALK SHALL BE CAREFULLY FINISHED WITH AN EDGING TOOL HAVING A RADIUS OF 1/2".
- EXPANSION JOINT: EXPANSION JOINTS BETWEEN THE SIDEWALKS AND THE CURB OR DRIVEWAY OR AT FIXED OBJECTS AND SIDEWALK INTERSECTIONS SHALL BE 1/2" MATERIAL SHALL MEET THE REQUIREMENTS OF AASHTO M153 OR AASHTO M213. FOR LONG POORS, AN EXPANSION JOINT SHALL BE PLACED AT INTERVALS NOT TO EXCEED 120'.
- CONTRACTION JOINTS:
OPEN TYPE JOINTS:
OPEN TYPE CONSTRUCTION JOINTS SHALL BE FORMED BY STAKING A METAL BULKHEAD IN PLACE AND DEPOSITING THE CONCRETE ON BOTH SIDES. AFTER THE CONCRETE HAS SET SUFFICIENTLY TO PRESERVE THE WIDTH AND THE SHAPE OF THE JOINT, THE BULKHEAD SHALL BE REMOVED. AFTER THE SIDEWALK HAS BEEN FINISHED OVER THE JOINT, THE SLOT SHALL BE FINISHED WITH A TOOL HAVING A 1/2" RADIUS.
SAWED JOINTS:
A SLOT APPROXIMATELY 3/16" WIDE AND NOT LESS THAN 1" DEEP AT 10' CENTERS SHALL BE CUT WITH A CONCRETE SAW AFTER THE CONCRETE HAS SET.
- SIDEWALKS ALONG OTHER STREETS SHALL BE CONSTRUCTED AND DEDICATED AS REQUIRED BY THE APPROVING AUTHORITY WHEN NECESSARY TO CONTINUE AN EXISTING OR PROPOSED SIDEWALK.
- HANDICAP RAMPS SHALL MEET FLORIDA ACCESSIBILITIES STANDARDS, AND SECTIONS 301.0, 301.1 AND 301.2.
- ALL SIDEWALKS ON R/W WITH 10' OF AN EXISTING OR PROPOSED TREE THAT WILL EXCEED 6" IN DIAMETER AT MATURITY SHALL BE 5" THICK AND CONTAIN 2-#3 REBAR CENTERED VERTICALLY AND SPACED 3' ON CENTER. PALMS ARE NOT CONSIDERED TREES.
- CONCRETE DRIVEWAY REPLACEMENT SHALL BE 6" CLASS I CONCRETE, 3000 PSI MIN. W/ FIBER.

*NOTE: FOR COMPLETE SIDEWALK DETAILS, SEE FDOT DESIGN STANDARDS, 2013 EDITION, INDEX 304, SHEETS 1 THROUGH 6 AND INDEX 310, SHEETS 1 & 2.

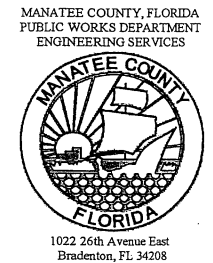
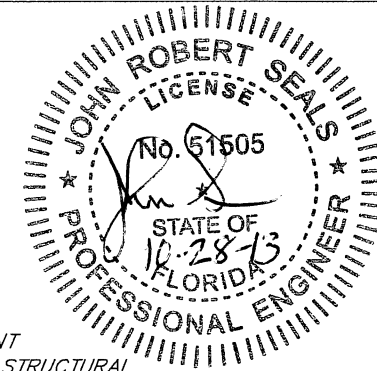

**57TH AVE. SIDEWALK FROM
US 41 TO 26TH ST. W.
MANATEE COUNTY, FL
TYPICAL SECTION**

NO.	DATE	BY	REVISION DESCRIPTION



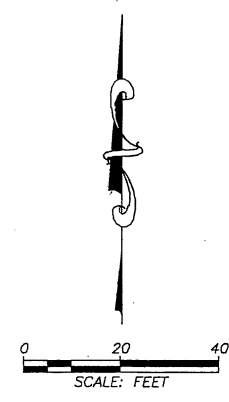
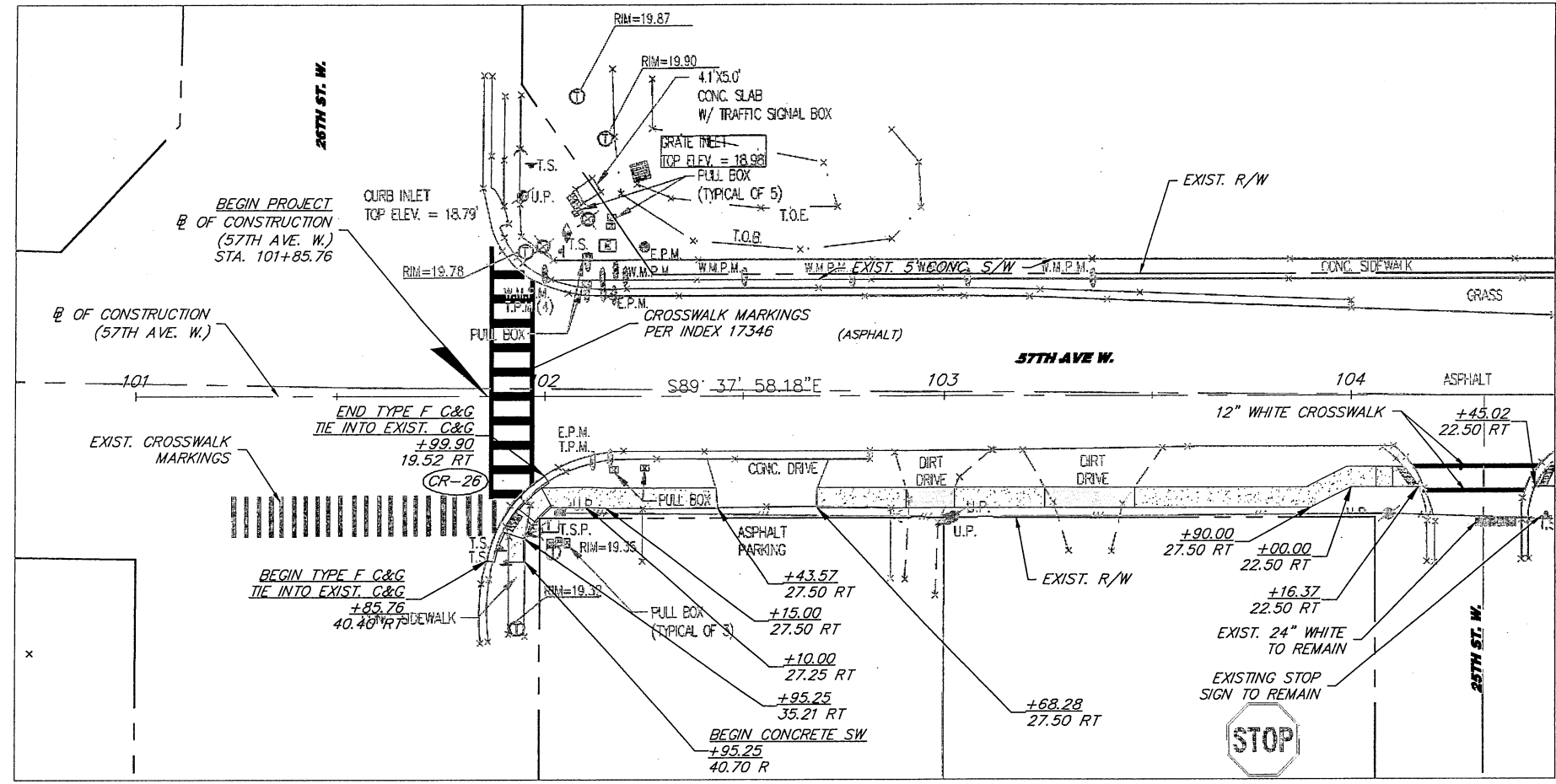

PROJECT #	9012180
SURVEY #	000
SEC./TWN./RGE	-----
SCALE	1"=40'
BY DATE	
SURVEYED	-----
DESIGNED	CKH 08/27/13
DRAWN	CKH 08/27/13
CHECKED	JRS 08/27/13

JOHN SEALS, P.E.
FLORIDA P.E. # 51505
Signature & Date
SHEET 5

**57TH AVE. SIDEWALK FROM
US 41 TO 26TH ST.W.
MANATEE COUNTY, FL
PLAN & PROFILE STA. 101+00 TO STA. 104+50**



LEGEND

-  CONC. SIDEWALK
-  6" CONC. SIDEWALK/ DRIVEWAY PAVEMENT
-  CONC. OR ASPHALT PAVEMENT REMOVAL
-  DETECTABLE WARNING SURFACE

- NOTE:**
- ALL CROSSWALKS SHALL HAVE A MINIMUM WIDTH OF 6 FEET BETWEEN PAINT LINES.
 - 24" STOP BAR TO BE PLACED 4' BEHIND CROSSWALK MARKINGS UNLESS OTHERWISE NOTED IN PLANS.

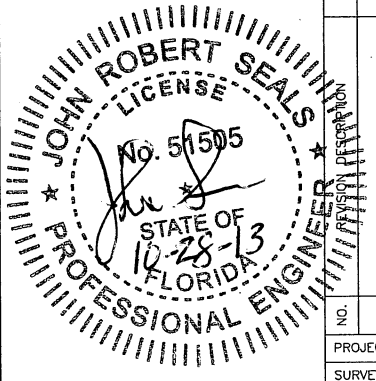
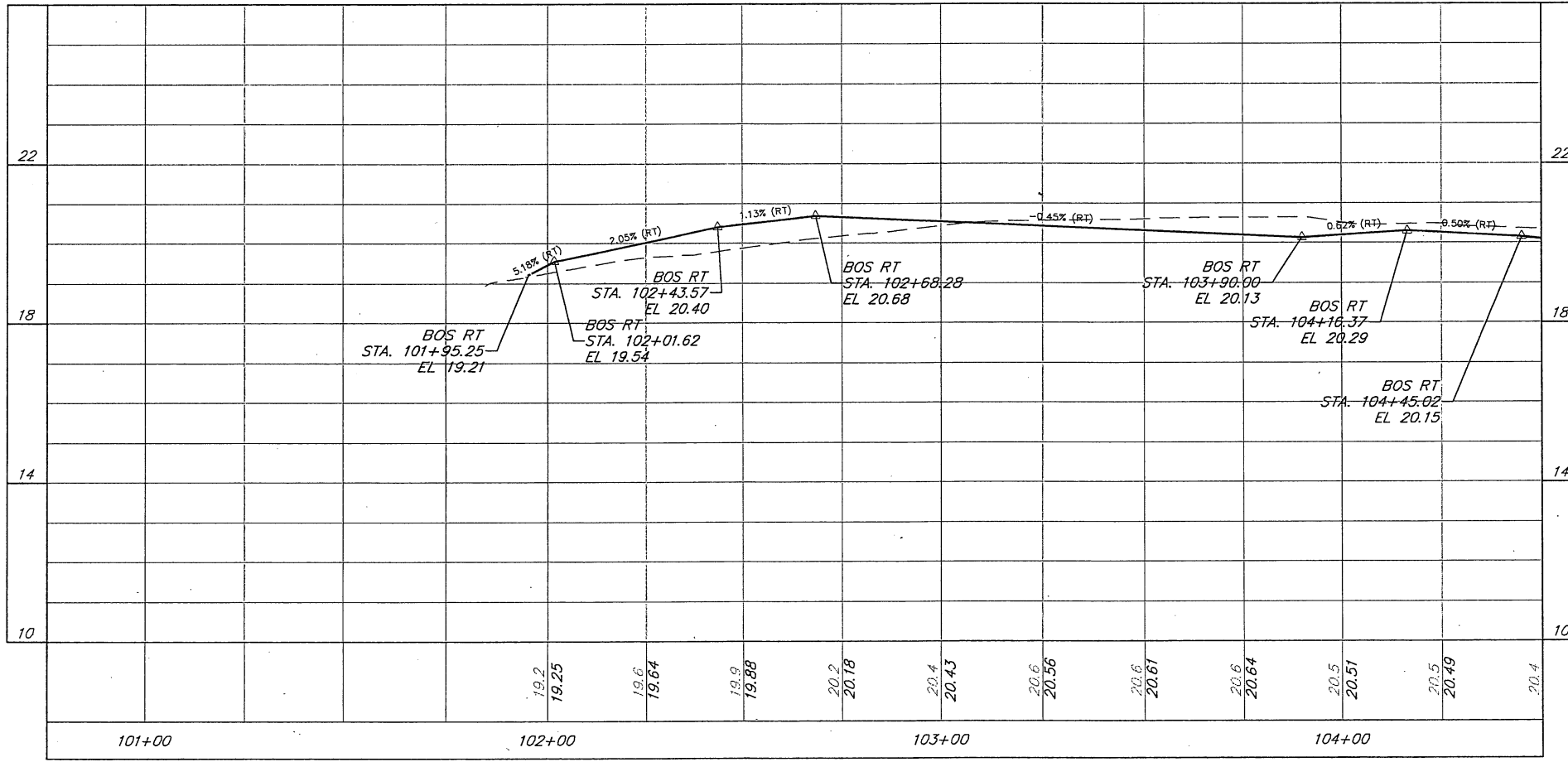

SCALE: 1" = 40' HORIZ.
SCALE: 1" = 5' VERT.

DATE	
BY	
NO.	
PROJECT #	9012180
SURVEY #	000
SEC./TWN./RGE	-----
SCALE	1" = 40'
	BY DATE
SURVEYED	-----
DESIGNED	CKH 08/27/13
DRAWN	CKH 08/27/13
CHECKED	JRS 08/27/13
JOHN SEALS, P.E.	
FLORIDA P.E. # 51505	
Signature & Date	
SHEET 6	

D:\PW-Civil\2013\10-27-2013\1121 AM Civil K. Hardie, 12.28.13, ANS A (8.59 x 11.00 inches)

57TH AVE. SIDEWALK FROM US 41 TO 26TH ST.W. MANATEE COUNTY, FL PLAN & PROFILE STA. 104+50 TO STA. 109+50

MATCH LINE STA. 104+50

MATCH LINE STA. 109+50

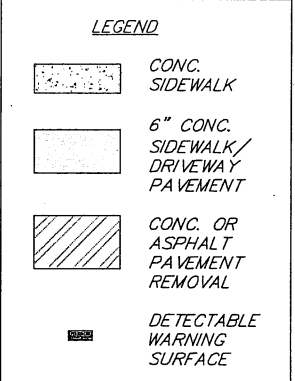
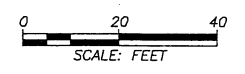
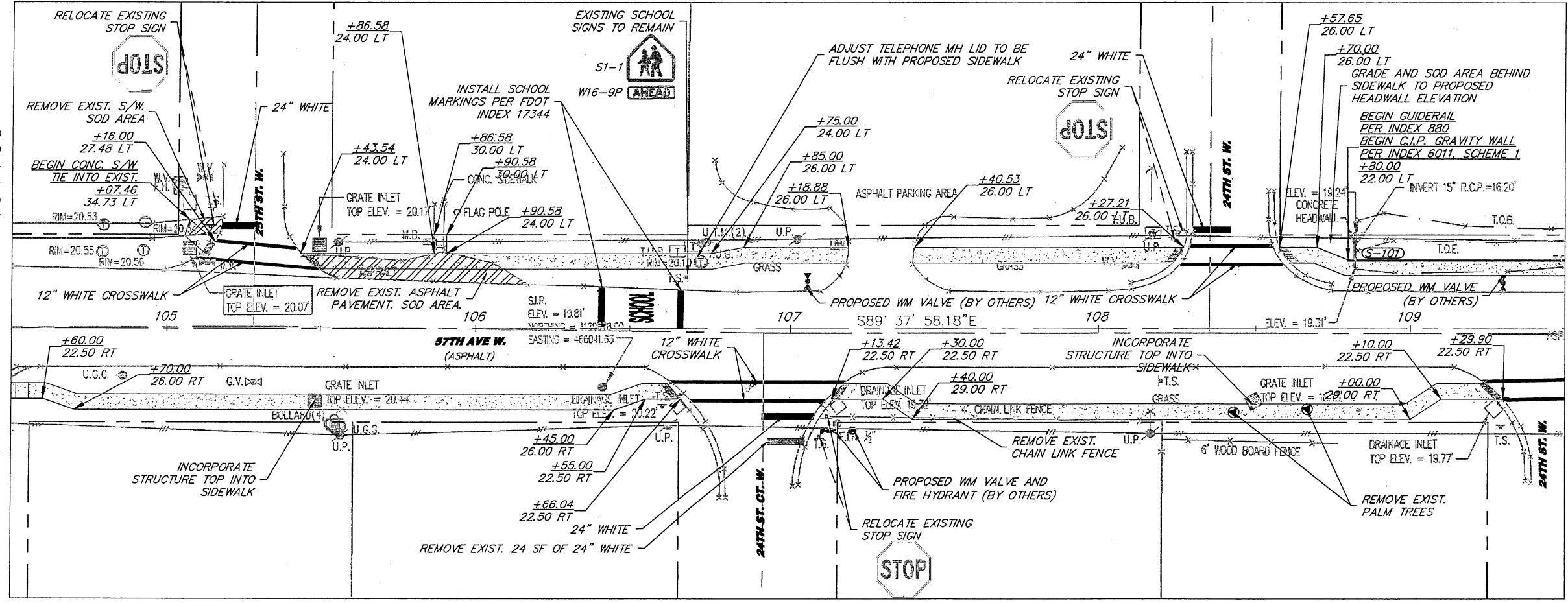

- NOTE:**
- ALL CROSSWALKS SHALL HAVE A MINIMUM WIDTH OF 6 FEET BETWEEN PAINT LINES.
 - 24\"/>

S-101
RECONSTRUCT CONCRETE ENDWALL. INCORPORATE EXISTING 15\"/>

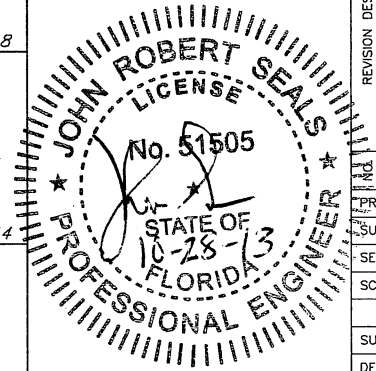

SCALE: 1\"/>

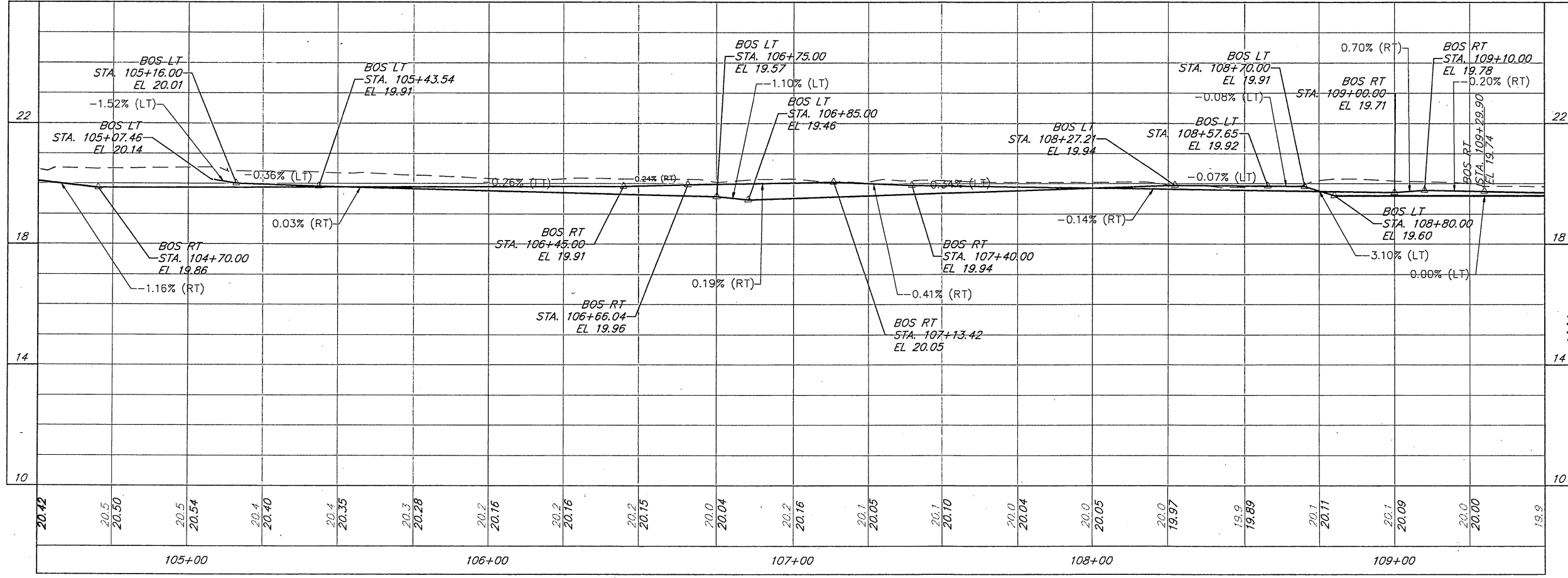

DATE	BY	REVISION DESCRIPTION

PROJECT #	9012180
SURVEY #	000
SEC./TWN./RGE	-----
SCALE	1"=40'
BY	DATE
SURVEYED	-----
DESIGNED	CKH 08/27/13
DRAWN	CKH 08/27/13
CHECKED	JRS 08/27/13
JOHN SEALS, P.E.	
FLORIDA P.E. # 51505	
Signature & Date	
SHEET 7	

G:\VW-CAD\26TH\26TH\CONC\CONC\PLANS\26_102713\11:21 AM\CONC.K_Herde_1125549_ANSI_A (6.50 x 11.00) (Metric).dwg

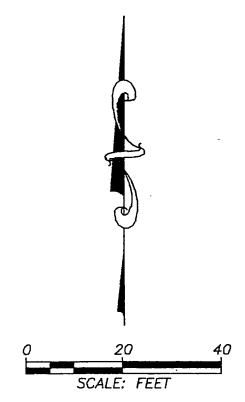
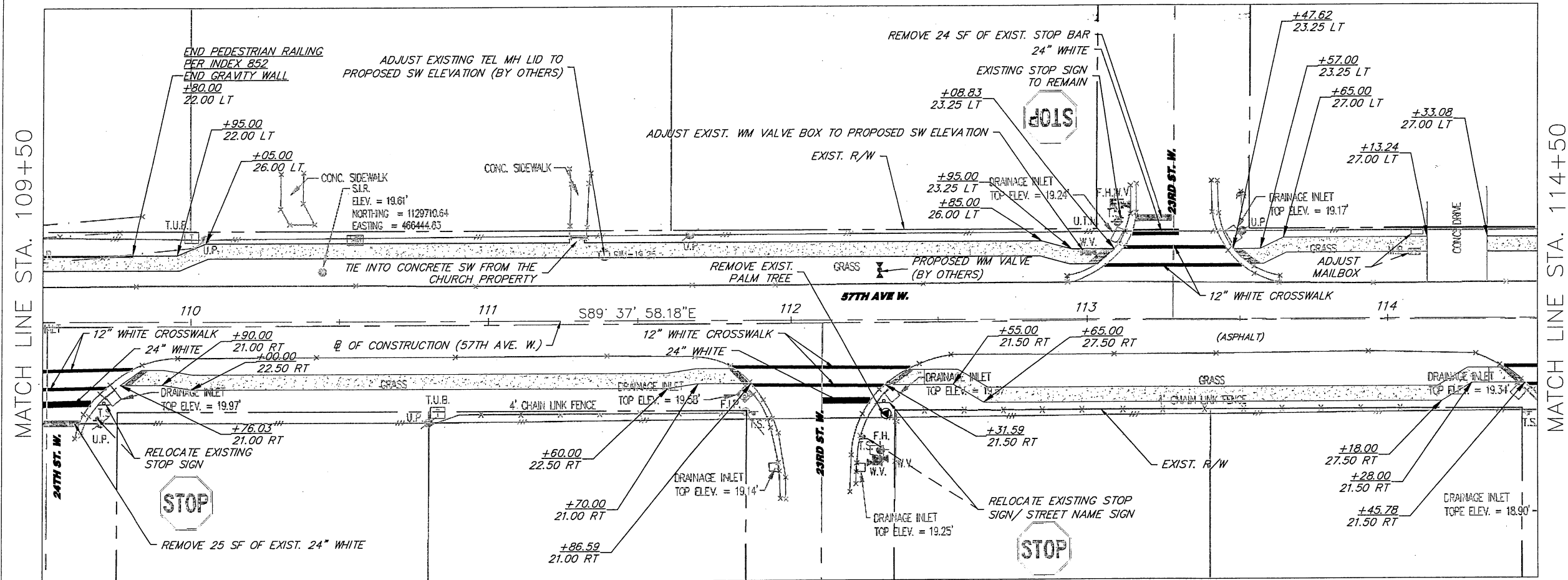

LEGEND

(Pattern)	CONC. SIDEWALK
(Pattern)	6" CONC. SIDEWALK/ DRIVEWAY PAVEMENT
(Pattern)	CONC. OR ASPHALT PAVEMENT REMOVAL
(Pattern)	DETECTABLE WARNING SURFACE

- NOTE:
- 1. ALL CROSSWALKS SHALL HAVE A MINIMUM WIDTH OF 6 FEET BETWEEN PAINT LINES.
 - 2. 24" STOP BAR TO BE PLACED 4' BEHIND CROSSWALK MARKINGS UNLESS OTHERWISE NOTED IN PLANS.

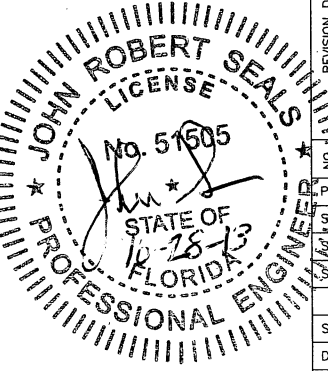
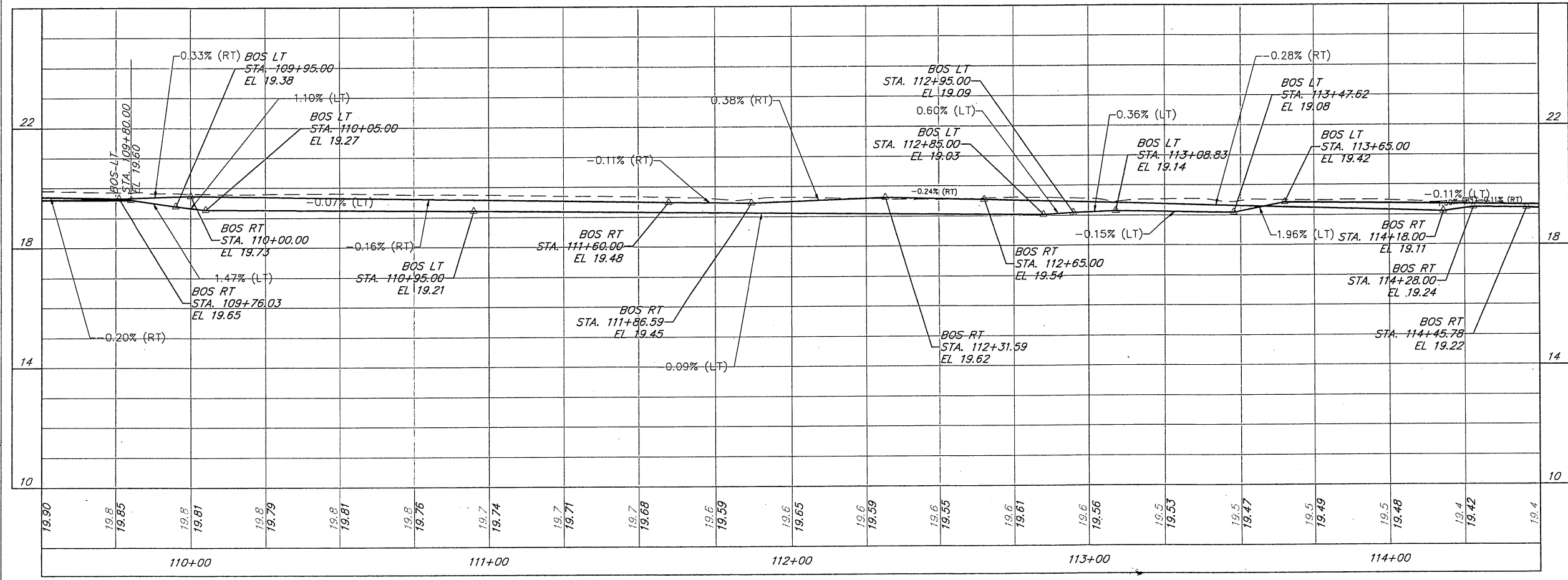

SCALE: 1"=40' HORIZ.
SCALE: 1"=5' VERT.

**57TH AVE. SIDEWALK FROM
US 41 TO 26TH ST.W.
MANATEE COUNTY, FL**

PLAN & PROFILE STA. 109+50 TO STA. 114+50

NO.	REVISION DESCRIPTION	DATE

PROJECT #	9012180
SURVEY #	000
SEC./TWN./RGE	
SCALE	1"=40'
BY DATE	
SURVEYED	
DESIGNED	CKH 08/27/13
DRAWN	CKH 08/27/13
CHECKED	JRS 08/27/13
JOHN SEALS, P.E. FLORIDA P.E. # 51505	
Signature & Date	

MATCH LINE STA. 114+50

MATCH LINE STA. 119+50

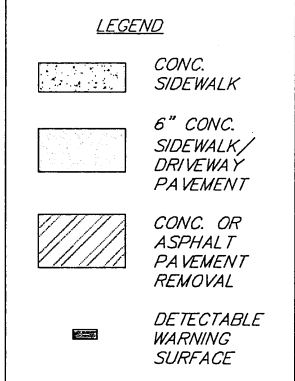
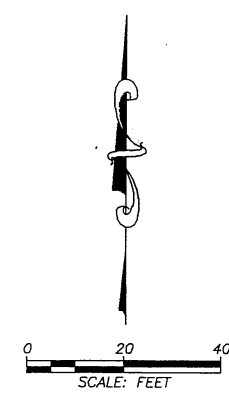
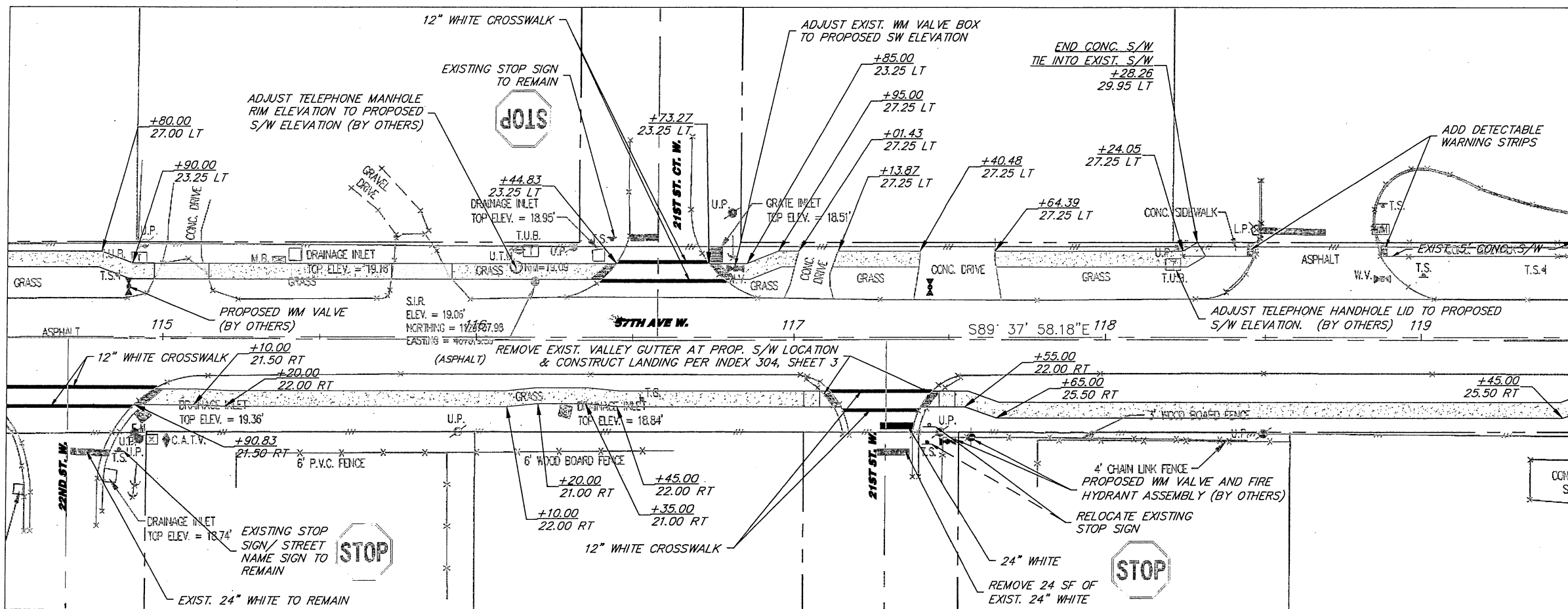

- NOTE:**
- ALL CROSSWALKS SHALL HAVE A MINIMUM WIDTH OF 6 FEET BETWEEN PAINT LINES.
 - 24" STOP BAR TO BE PLACED 4' BEHIND CROSSWALK MARKINGS UNLESS OTHERWISE NOTED IN PLANS.

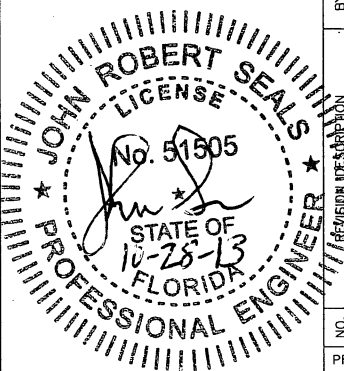
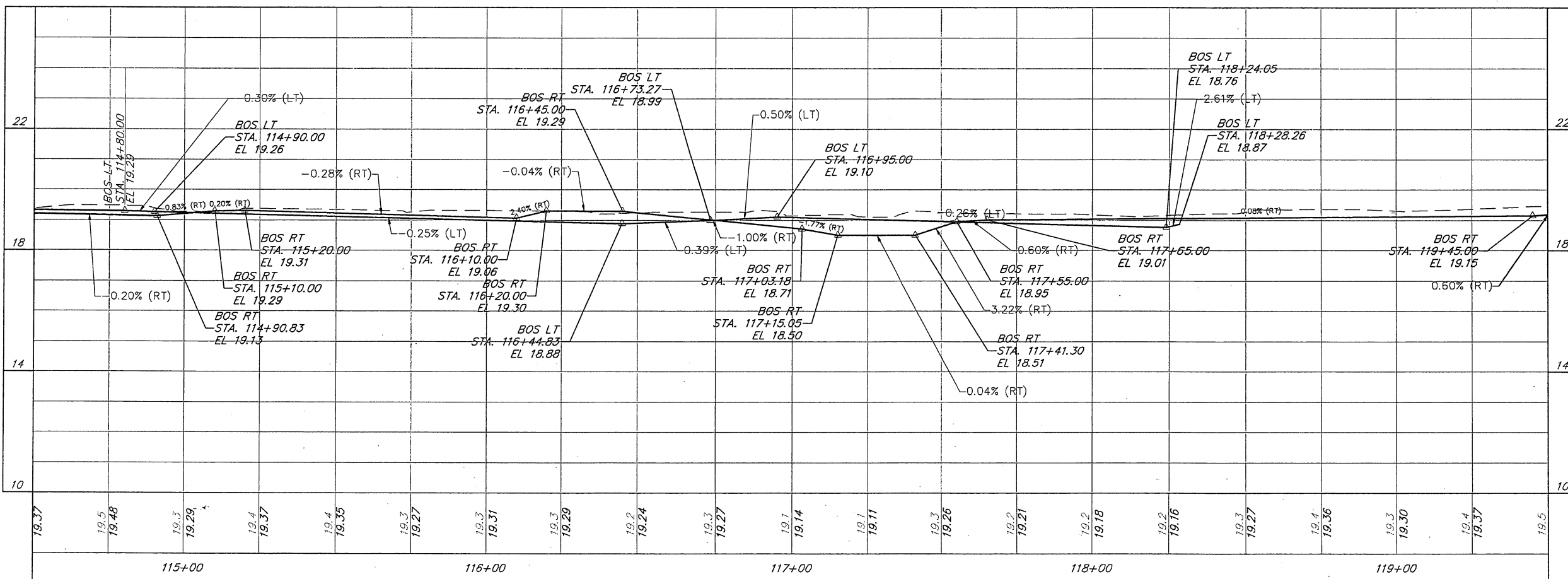

SCALE: 1"=40' HORIZ.
SCALE: 1"=5' VERT.

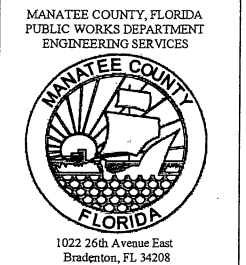

**57TH AVE. SIDEWALK FROM
US 41 TO 26TH ST.W.
MANATEE COUNTY, FL
PLAN & PROFILE STA. 114+50 TO STA. 119+50**

DATE	
BY	
NO.	
PROJECT #	9012180
SURVEY #	000
SEC./TWN./RGE	---
SCALE	1"=40'
SURVEYED	---
DESIGNED	CKH 08/27/13
DRAWN	CKH 08/27/13
CHECKED	JRS 08/27/13
JOHN SEALS, P.E.	
FLORIDA P.E. # 51505	
Signature & Date	
SHEET 9	

MATCH LINE STA. 119+50

MATCH LINE STA. 124+50

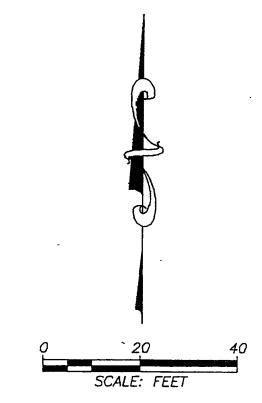
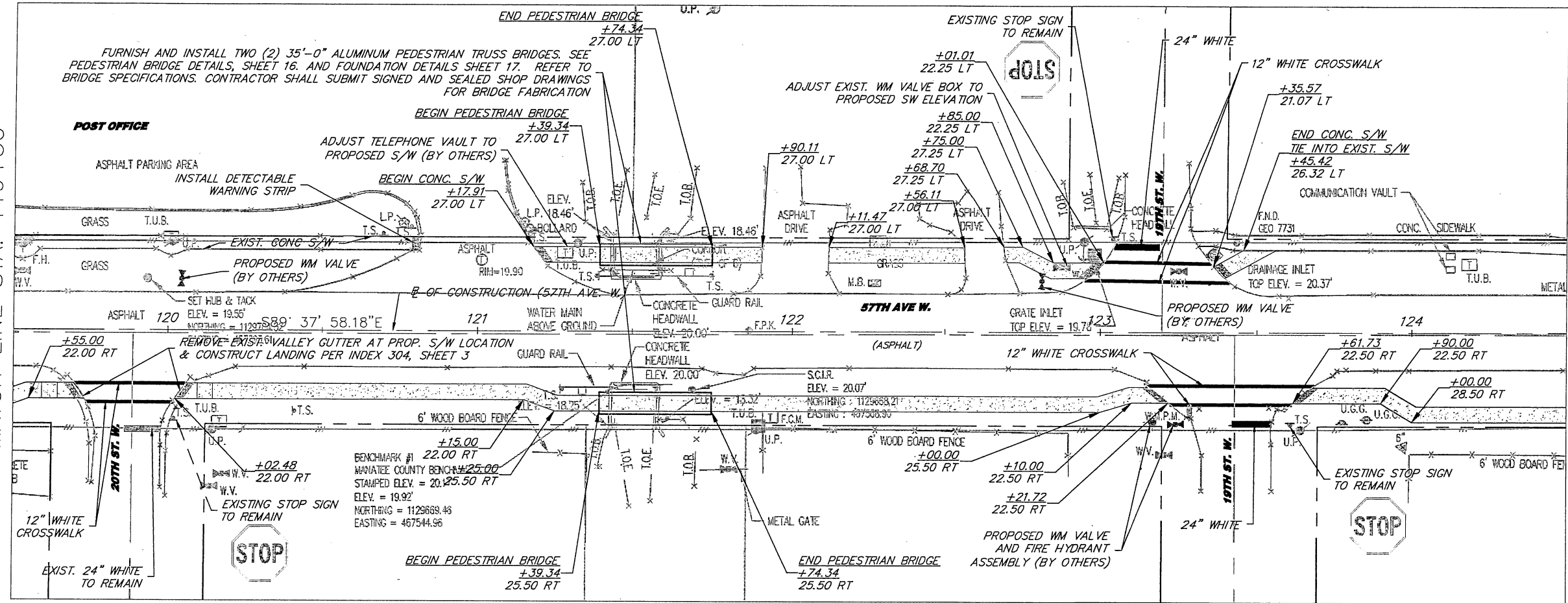

LEGEND

	CONC. SIDEWALK
	6" CONC. SIDEWALK/ DRIVEWAY PAVEMENT
	CONC. OR ASPHALT PAVEMENT REMOVAL
	DETECTABLE WARNING SURFACE

- NOTE:**
- ALL CROSSWALKS SHALL HAVE A MINIMUM WIDTH OF 6 FEET BETWEEN PAINT LINES.
 - 24" STOP BAR TO BE PLACED 4' BEHIND CROSSWALK MARKINGS UNLESS OTHERWISE NOTED IN PLANS.
 - THE FOLLOWING SIDE STREETS ON THE SOUTHSIDE OF 57TH AVE. W. WILL BE RESURFACED UNDER A SEPARATE PROJECT:
19TH ST. W.
18TH ST. W.
17TH ST. W.
16TH ST. W.

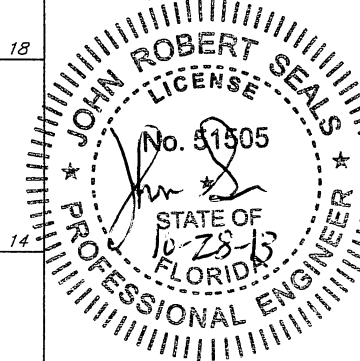
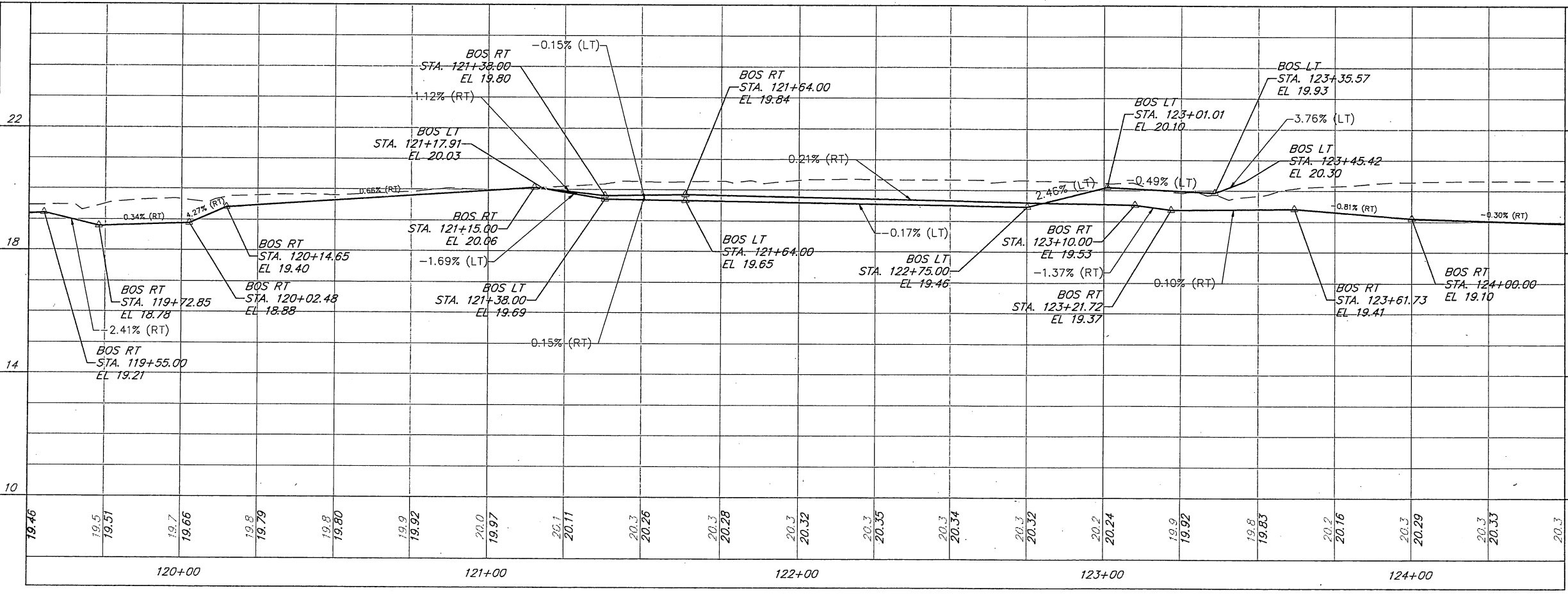

SCALE: 1" = 40' HORIZ.
SCALE: 1" = 5' VERT.

**57TH AVE. SIDEWALK FROM
US 41 TO 26TH ST. W.
MANATEE COUNTY, FL
PLAN & PROFILE STA. 119+50 TO STA. 124+50**

NO.	DATE	BY	REVISION DESCRIPTION

PROJECT #	9012180
SURVEY #	000
SEC./TWN./RGE	---
SCALE	1"=40'
SURVEYED	---
DESIGNED	CKH 08/27/13
DRAWN	CKH 08/27/13
CHECKED	JRS 08/27/13
JOHN SEALS, P.E.	
FLORIDA P.E. # 51505	
Signature & Date	

0:\PW-Civil\2013\08\13\08130813\11:22 AM\John K. Herald, 12:56:46, ANSI X (8.50 x 11.00 inches)

MATCH LINE STA. 124+50

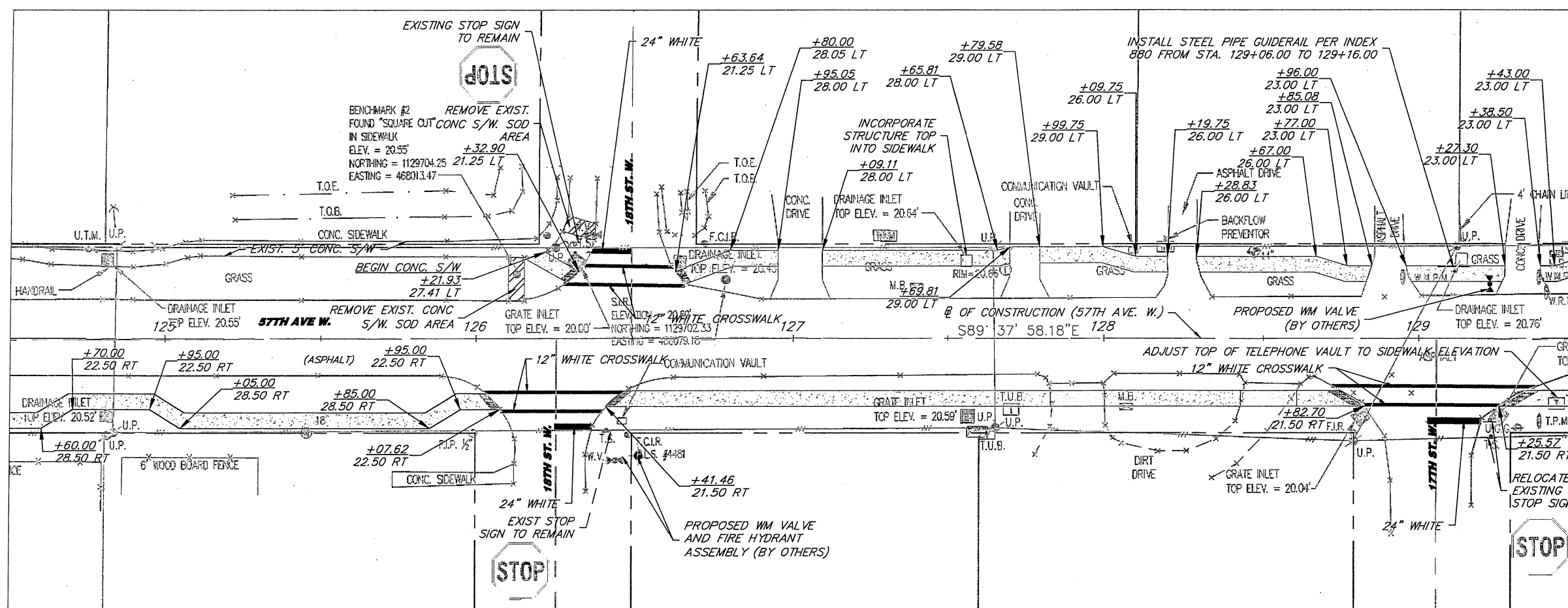

MATCH LINE STA. 129+50

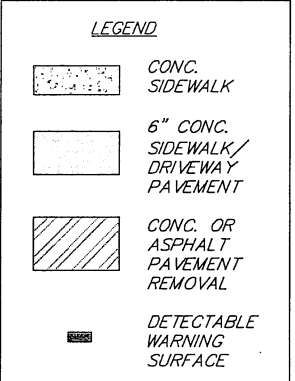
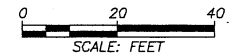

- NOTE:**
- ALL CROSSWALKS SHALL HAVE A MINIMUM WIDTH OF 6 FEET BETWEEN PAINT LINES.
 - 24" STOP BAR TO BE PLACED 4' BEHIND CROSSWALK MARKINGS UNLESS OTHERWISE NOTED IN PLANS.
 - THE FOLLOWING SIDE STREETS ON THE SOUTHSIDE OF 57TH AVE. W. WILL BE RESURFACED UNDER A SEPARATE PROJECT:
19TH ST. W.
18TH ST. W.
17TH ST. W.
16TH ST. W.

57TH AVE. SIDEWALK FROM US 41 TO 26TH ST.W. MANATEE COUNTY, FL PLAN & PROFILE STA. 124+50 TO STA. 129+50

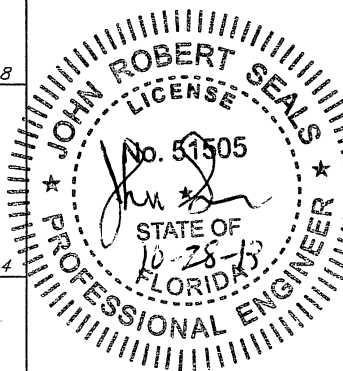
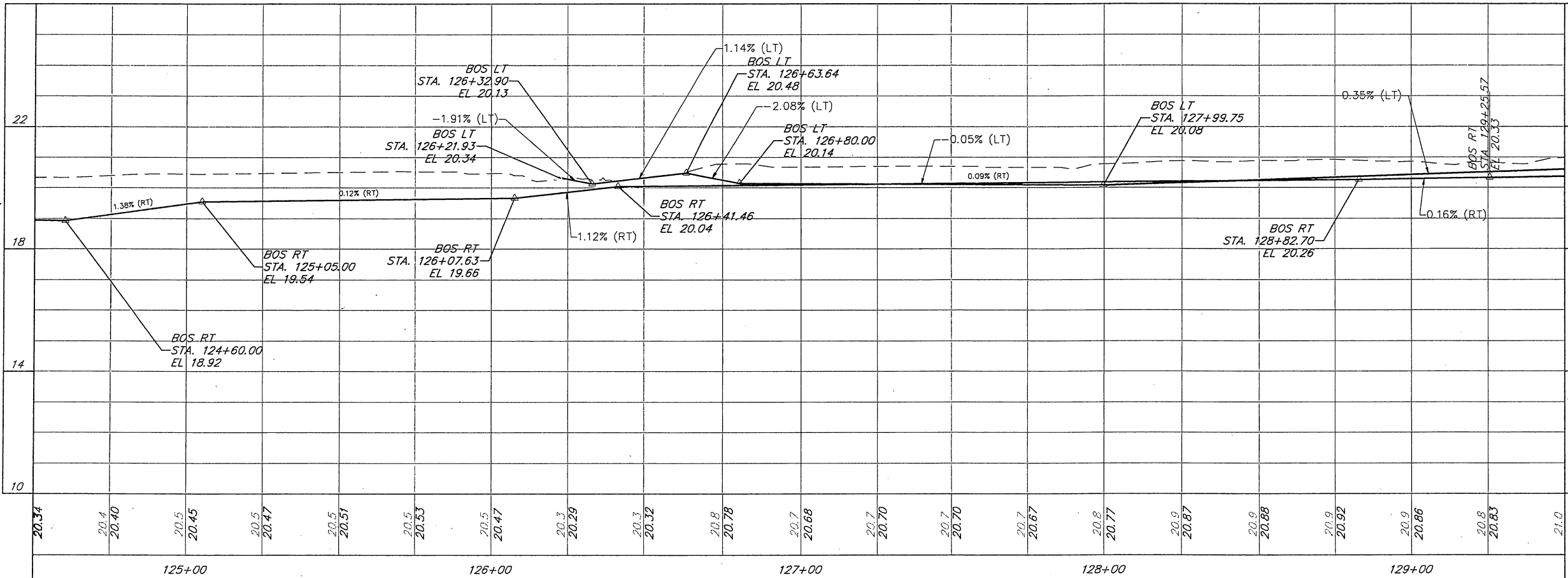

SCALE: 1" = 40' HORIZ.
SCALE: 1" = 5' VERT.

REVISION DESCRIPTION		DATE

PROJECT #	9012180
SURVEY #	000
SEC./TWN./RGE	-----
SCALE	1" = 40'
BY	DATE
SURVEYED	-----
DESIGNED	CKH 08/27/13
DRAWN	CKH 08/27/13
CHECKED	JRS 08/27/13
JOHN SEALS, P.E.	
FLORIDA P.E. # 51505	
Signature & Date	
SHEET 11	

D:\VW-CWA\281\000\Cadd\GVSS\PERIOD1.dwg:PLAN06_10/27/2013 11:22 AM Edwin K. Harde, 1:2,5648, ANSI A (8.50 x 11.00 Inches)

MATCH LINE STA. 129+50

MATCH LINE STA. 134+50

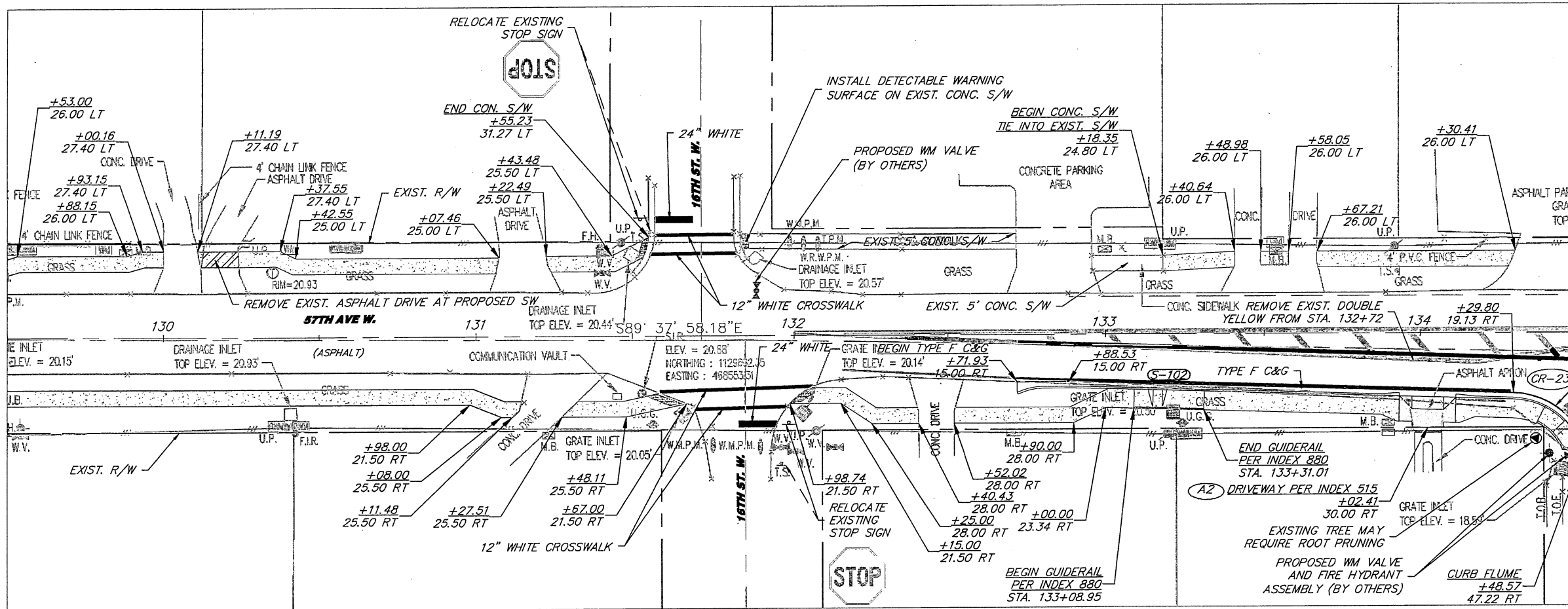

LEGEND

- CONC. SIDEWALK
- 6" CONC. SIDEWALK DRIVEWAY PAVEMENT
- CONC. OR ASPHALT PAVEMENT REMOVAL
- DETECTABLE WARNING SURFACE

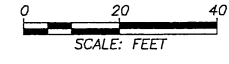

- NOTE:**
1. ALL CROSSWALKS SHALL HAVE A MINIMUM WIDTH OF 6 FEET BETWEEN PAINT LINES.
 2. 24" STOP BAR TO BE PLACED 4' BEHIND CROSSWALK MARKINGS UNLESS OTHERWISE NOTED IN PLANS.
 3. THE FOLLOWING SIDE STREETS ON THE SOUTHSIDE OF 57TH AVE. W. WILL BE RESURFACED UNDER A SEPARATE PROJECT:
19TH ST. W.
18TH ST. W.
17TH ST. W.
16TH ST. W.

S-102
CONSTRUCT SIDEWALK FLUME STA. 133+16.45, 17.32' RT DRAIN TO EXIST. INLET PER FDOT INDEX 216

D:\PWP-Civil\281\1000\1000\1000\CADD\PLANS\PLANS\170724\2013 11:22 AM Civil K. Horne, 1:2:54:49, ANSI A (8.50 x 11.00 inches)

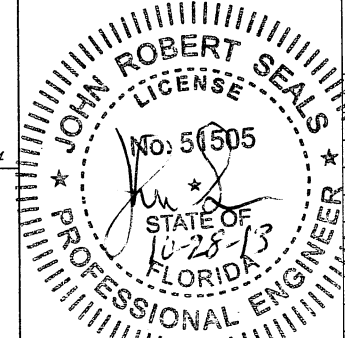
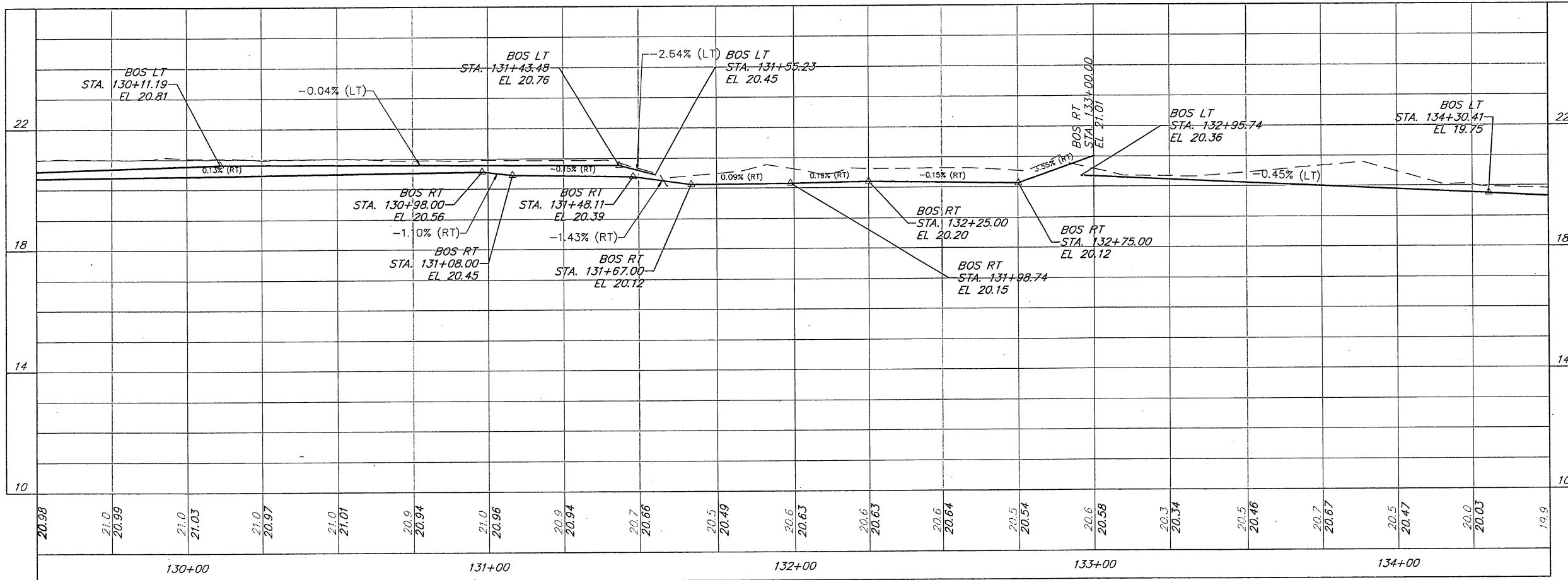

SCALE: 1"=40' HORIZ.
SCALE: 1"=5' VERT.

NO.	DATE	BY	REVISION DESCRIPTION

PROJECT #	9012180
SURVEY #	000
SEC./TWN./RGE	-----
SCALE	1"=40'
SURVEYED	----
DESIGNED	CKH 08/27/13
DRAWN	CKH 08/27/13
CHECKED	JRS 08/27/13

**57TH AVE. SIDEWALK FROM
US 41 TO 26TH ST. W.
MANATEE COUNTY, FL
PLAN & PROFILE STA. 129+50 TO STA. 134+50**

JOHN SEALS, P.E.
FLORIDA P.E. # 51505

Signature & Date
SHEET 12

MATCH LINE STA. 134+50

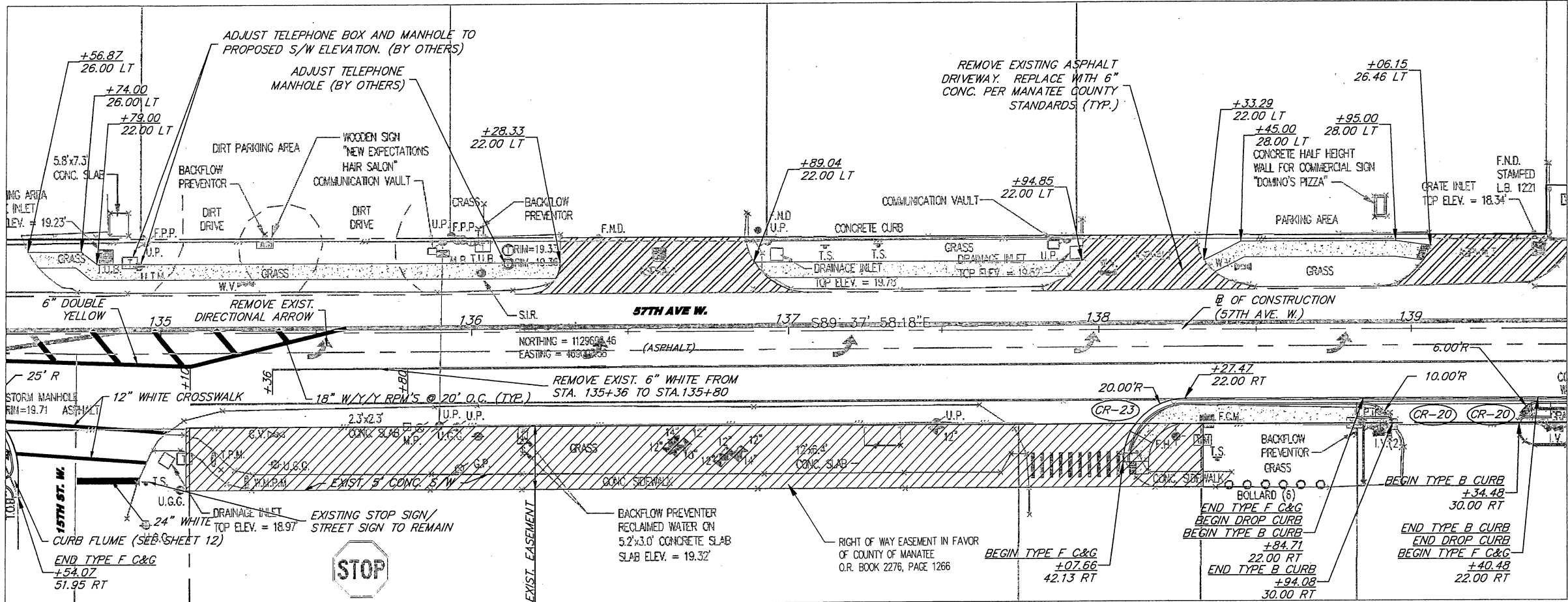

MATCH LINE STA. 139+50

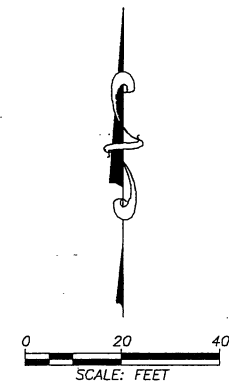

LEGEND

	CONC. SIDEWALK
	6" CONC. SIDEWALK/ DRIVEWAY PAVEMENT
	CONC. OR ASPHALT PAVEMENT REMOVAL
	DETECTABLE WARNING SURFACE

- NOTE:**
- ALL CROSSWALKS SHALL HAVE A MINIMUM WIDTH OF 6 FEET BETWEEN PAINT LINES.
 - 24" STOP BAR TO BE PLACED 4' BEHIND CROSSWALK MARKINGS UNLESS OTHERWISE NOTED IN PLANS.

**57TH AVE. SIDEWALK FROM
US 41 TO 26TH ST.W.
MANATEE COUNTY, FL
PLAN & PROFILE STA. 134+50 TO STA. 139+50**

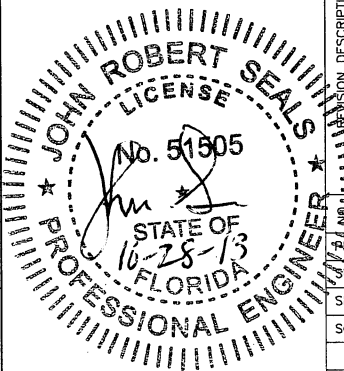
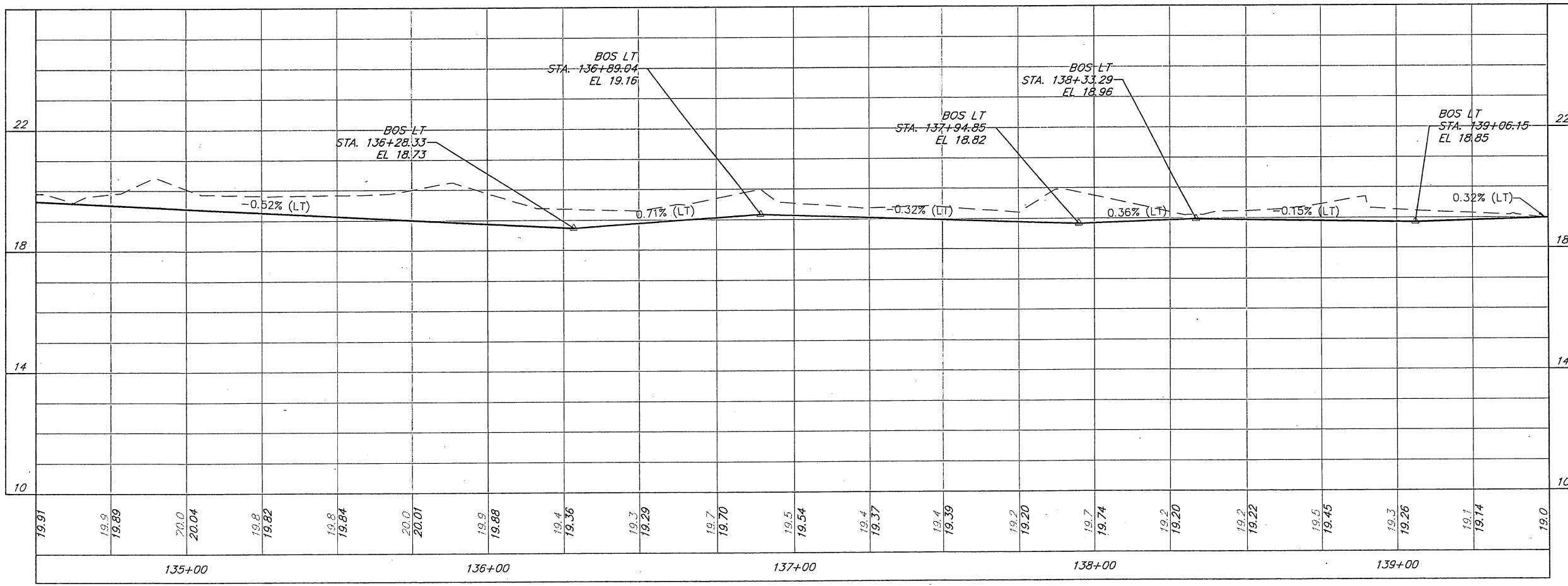

SCALE: 1" = 40' HORIZ.
SCALE: 1" = 5' VERT.

DATE		
BY		
DESCRIPTION		
PROJECT #	9012180	
SURVEY #	000	
SEC./TWN./RGE		
SCALE	1" = 40'	
	BY	DATE
SURVEYED		
DESIGNED	CKH	08/27/13
DRAWN	CKH	08/27/13
CHECKED	JRS	08/27/13
JOHN SEALS, P.E.		
FLORIDA P.E. # 51505		
Signature & Date		
SHEET 13		

C:\PW-Civil\B281\000\000\000\CADD\PLAN\10724\2013 11:22 AM Civil K. Hardie, 12.25.13.dwg

G:\V\F-Civil\8581\0000\Cadd\Cadd\PLANS\10/24/2013 11:22 AM Calvin K. Horvath, 1235843, MSJ A (6.50 x 11.00 Inches)

MATCH LINE STA. 139+50

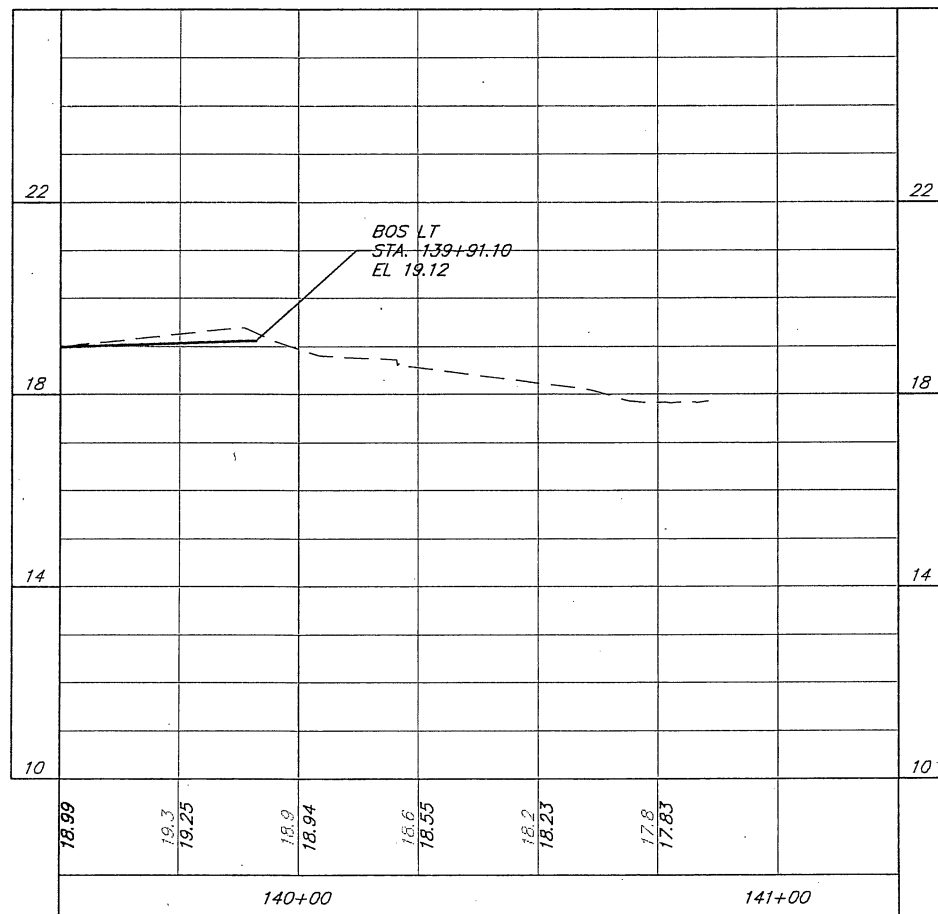
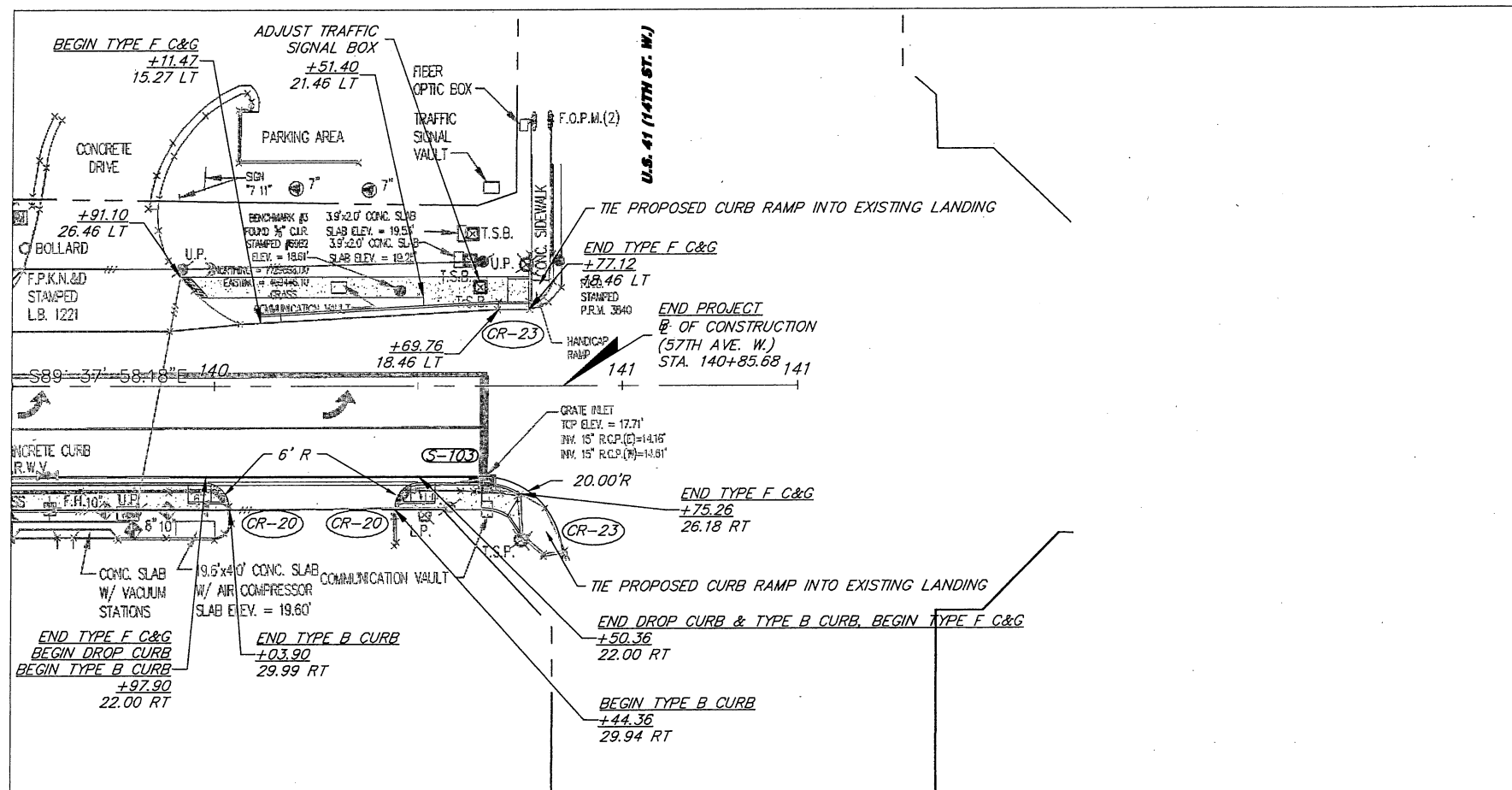

SCALE: 1" = 40' HORZ.
SCALE: 1" = 5' VERT.

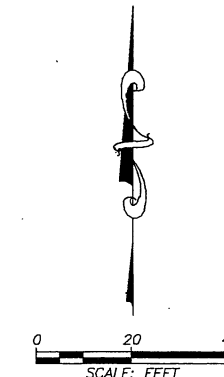

LEGEND	
	CONC. SIDEWALK
	6" CONC. SIDEWALK/DRIVEWAY PAVEMENT
	CONC. OR ASPHALT PAVEMENT REMOVAL
	DETECTABLE WARNING SURFACE

NOTE:
1. THE COST OF ANY PIPE REMOVAL AND THE COST OF REMOVAL OF THE EXISTING STRUCTURE REQUIRED FOR THE CONSTRUCTION OF STRUCTURE S-103 SHALL BE INCLUDED IN THE COST OF THE PROPOSED STRUCTURE S-103.

S-103
REMOVE EXIST. GRATE INLET AND STRUCTURE.
INSTALL TYPE 9 CURB INLET STA. 140+64.17, 23.00' RT
FOOT INDEX 200, 201, 214

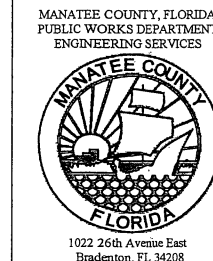

57TH AVE. SIDEWALK FROM US 41 TO 26TH ST.W. MANATEE COUNTY, FL PLAN & PROFILE STA. 139+50 TO STA. 141+43

NO.	REVISION DESCRIPTION	BY	DATE

PROJECT # 9012180
SURVEY # 000
SEC./TWN./RGE -----
SCALE 1" = 40'

	BY	DATE
SURVEYED	-----	-----
DESIGNED	CKH	08/27/13
DRAWN	CKH	08/27/13
CHECKED	JRS	08/27/13

JOHN SEALS, P.E.
FLORIDA P.E. # 51505

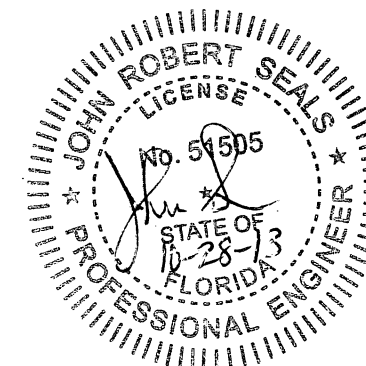

**57TH AVE. SIDEWALK FROM
US 41 TO 26TH ST.W.
MANATEE COUNTY, FL
DRAINAGE CROSS SECTION**

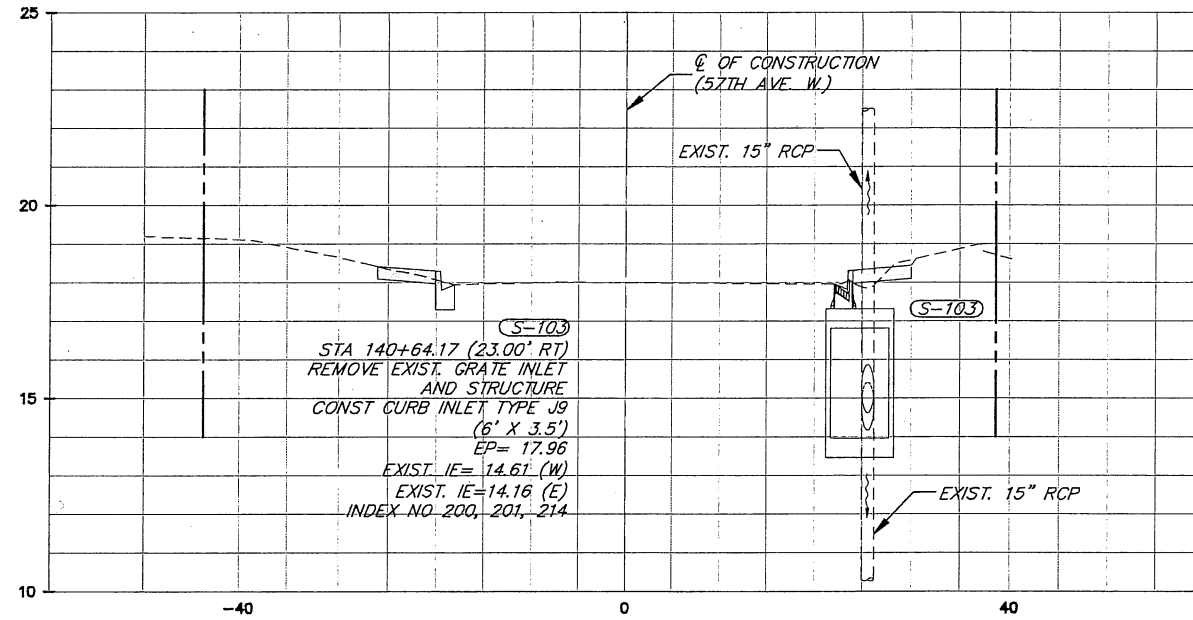

140+64.17

HORIZ. 1"=20'
VERT. 1"=5'

D:\p\cmt\1000\1000\cadd\GIS\files\SD01.dwg DRG XSEC. 10/24/2013 11:23 AM Colin K. Hordle, P.E. ANSI D (22.00 x 34.00 Inches)

NO.	REVISION DESCRIPTION	BY	DATE

PROJECT #	9012180
SURVEY #	000
SEC./TWN./RGE	----
SCALE	1"=40'
SURVEYED	----
DESIGNED	CKH 08/27/13
DRAWN	CKH 08/27/13
CHECKED	JRS 08/27/13

JOHN SEALS, P.E.
FLORIDA P.E. # 51505

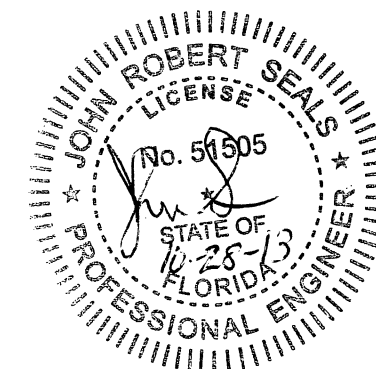

**57TH AVE. SIDEWALK FROM
US 41 TO 26TH ST.W.
MANATEE COUNTY, FL
PEDESTRIAN BRIDGE DETAILS**

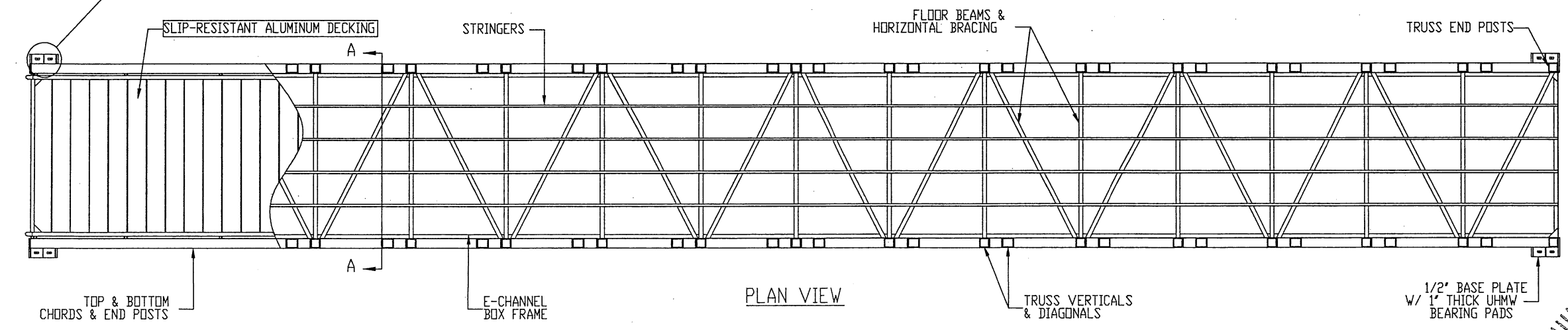
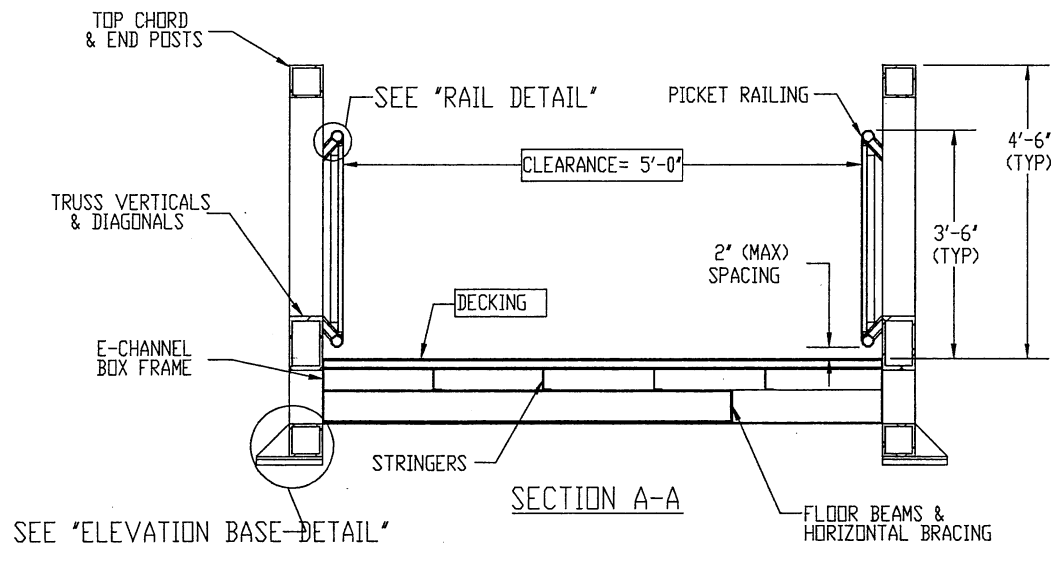
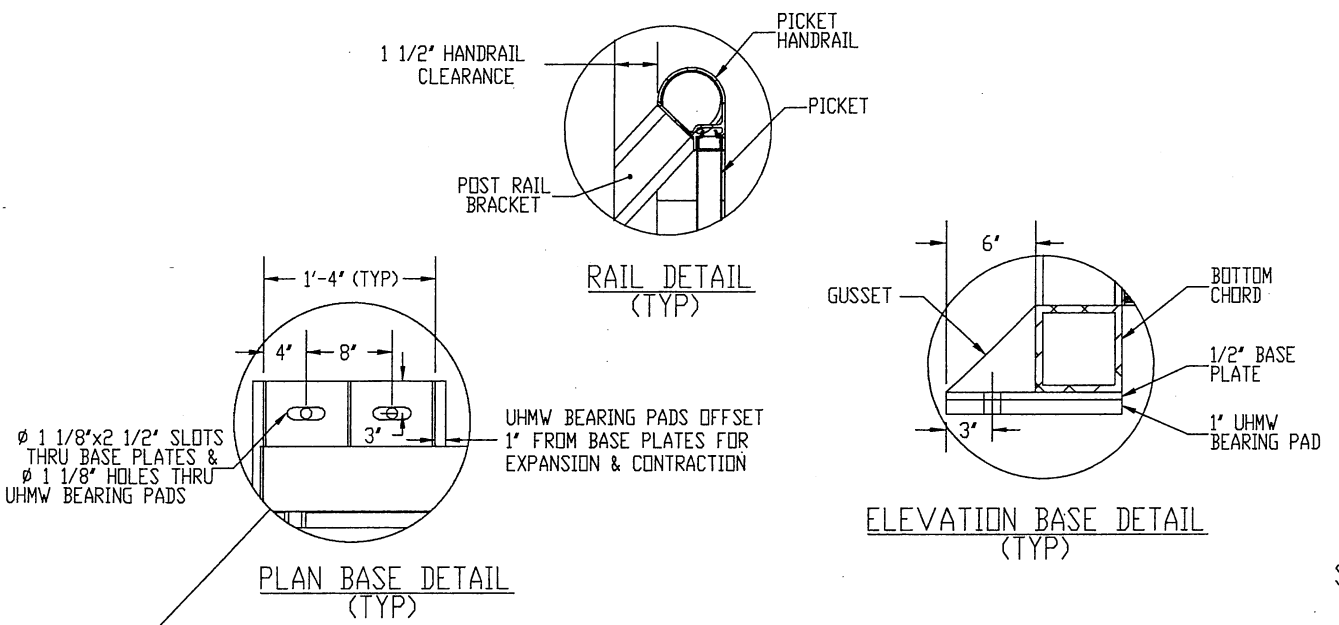
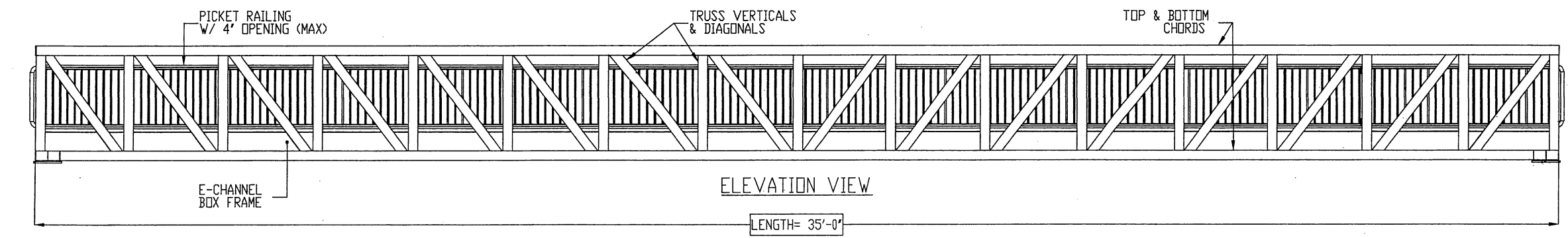

NO.	REVISION DESCRIPTION	BY	DATE

PROJECT #	9012180	
SURVEY #	000	
SEC./TWN./RGE	----	
SCALE	1"=40'	
SURVEYED	BY	DATE
DESIGNED	CKH	08/27/13
DRAWN	CKH	08/27/13
CHECKED	JRS	08/27/13

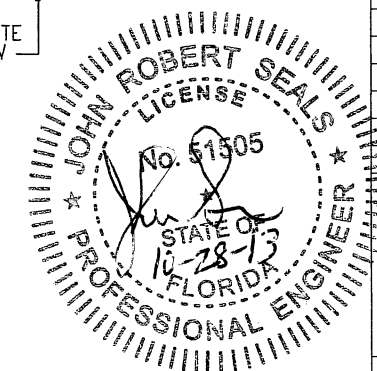

JOHN SEALS, P.E.
FLORIDA P.E. # 51505

D:\PW-GMA\2611\000\000\CADD\CADD\57TH\001.dwg PEDESTRIAN BRIDGE DETAILS, 10/24/2013 11:23 AM Calvin K. Herring, 1:1, ANSI D (22.00 x 34.00 inches)

**57TH AVE. SIDEWALK FROM
US 41 TO 26TH ST.W.
MANATEE COUNTY, FL
PEDESTRIAN BRIDGE FOUNDATION**

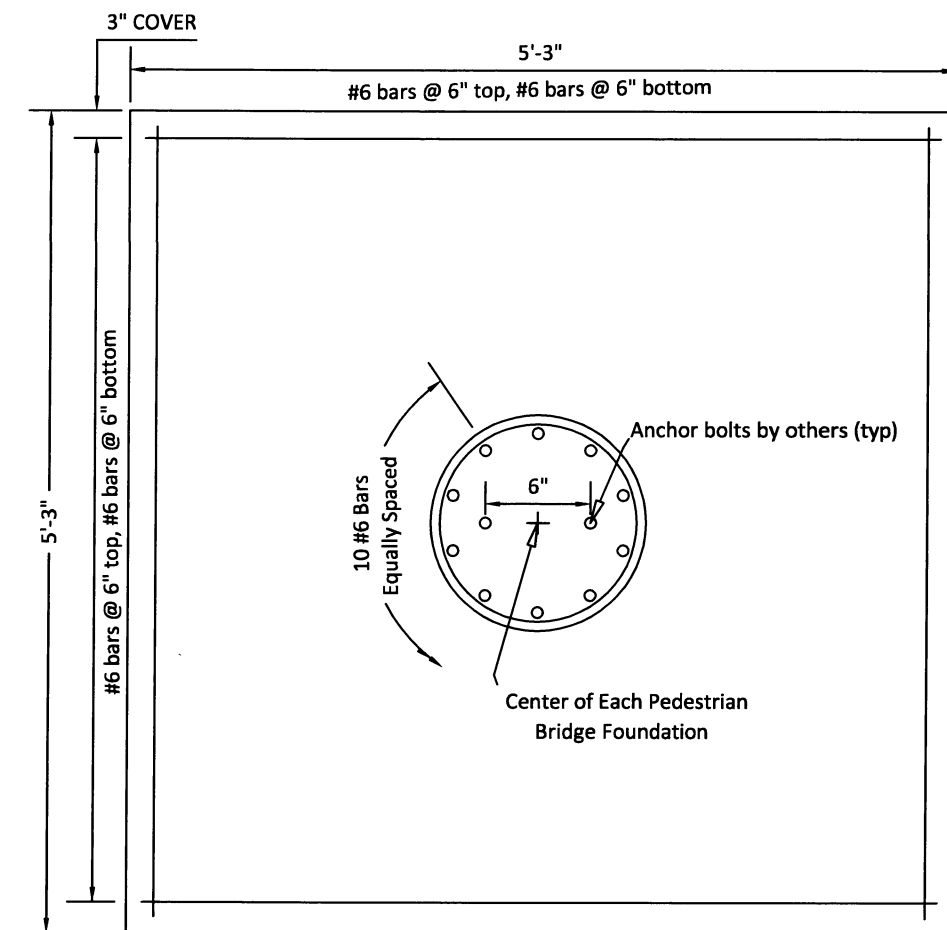

FOOTING PLAN

Direction of Stationing →

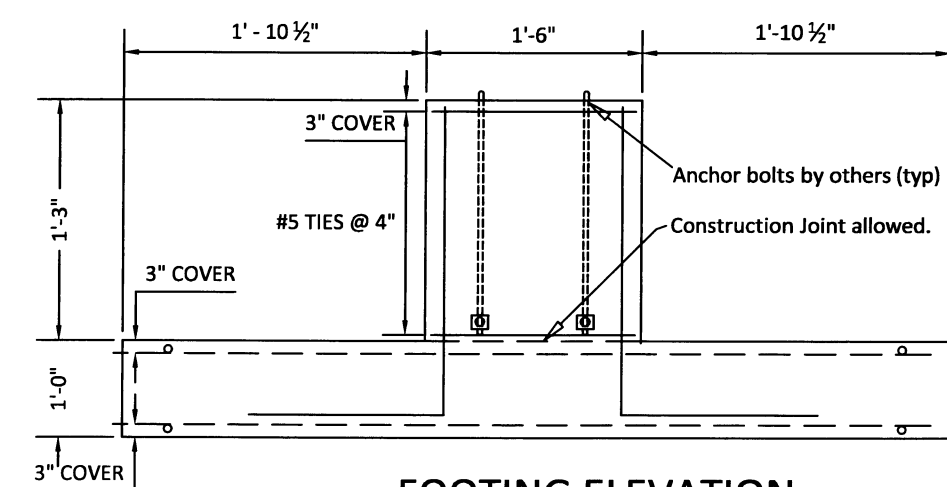

FOOTING ELEVATION

Direction of Stationing →

#5 TIES DETAIL

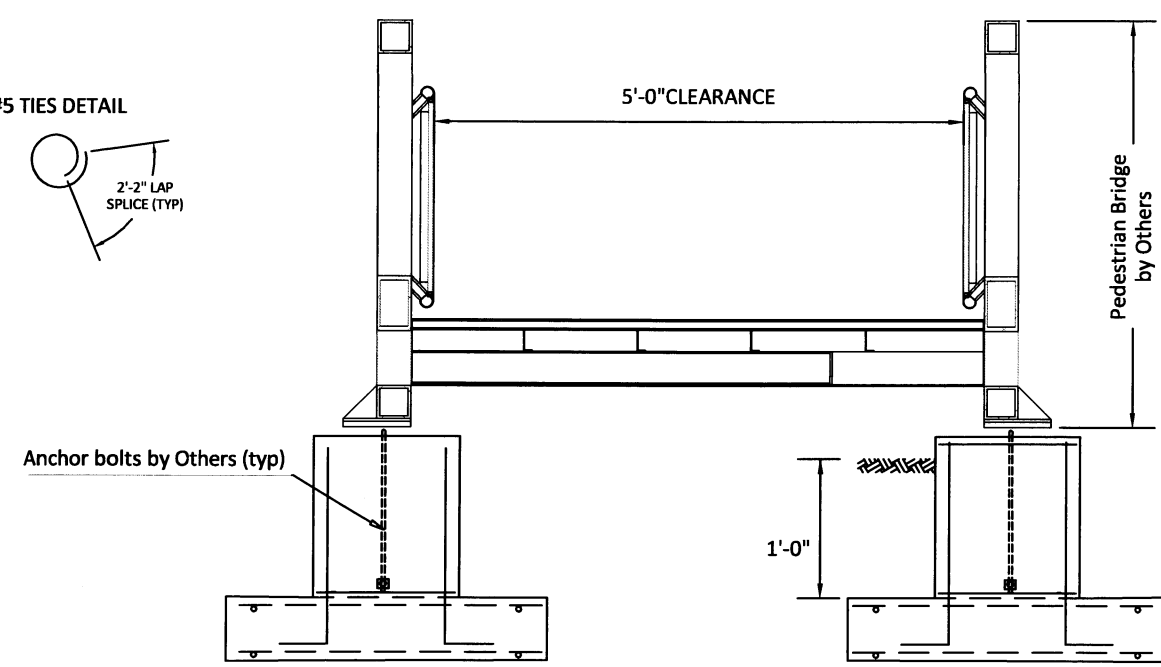
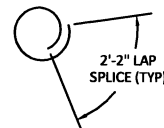

BRIDGE END ELEVATION

Centers of each Pedestrian Bridge Foundation shall be placed at the following stations and offsets:

- Northern-most Foundations**
 121+39.34, 27.00' Lt
 121+39.34, 19.27' Lt
 121+74.34, 27.00' Lt
 121+74.34, 19.27' Lt

- Southern-most Foundations**
 121+39.34, 25.5' Rt
 121+39.34, 17.77' Rt
 121+74.34, 25.5' Rt
 121+74.34, 17.77' Rt

Notes:

- Fy = 60 ksi
- f'c = 5,500 psi
- Assumed soil conditions:
- Buoyant Unit Weight = 37 pcf
- Soil Friction Angle = 26°
- Allowable Bearing Pressure = 2 ksf

Allowable Service Loadings on Each Foundation:
 Vertical = 7.5 kip
 Horizontal = 1.5 kip

Pedestrian Bridge Shop Drawings must be submitted to the following and approved prior to fabrication of any and all bridge and/or foundation component(s):

Thomas E. Slaughter, Jr., P.E.
 MAP Engineering Company
 550 N. Reo Street, Suite 300
 Tampa, FL 33609

Contractor shall verify foundation locations properly and match anchor bolt locations prior to Pedestrian Bridge Fabrication and prior to construction of each foundation.

T.E.S.
2013.10.28

Thomas E. Slaughter, Jr., P.E.
 #38833
 MAP Engineering Company
 550 N. Reo Street, Suite 300
 Tampa, FL 33609
 C.A. 6772

NO.	REVISION DESCRIPTION	BY	DATE

PROJECT #	9012180
SURVEY #	000
SEC./TWN./RGE	-----
SCALE	1"=40'
SURVEYED	-----
DESIGNED	CKH 10/27/13
DRAWN	CKH 10/27/13
CHECKED	JRS 10/27/13

T.E. SLAUGHTER, JR., P.E.
 FLORIDA P.E. # 38833

Signature & Date