

REQUEST FOR PROPOSALS  
No. 26-R089352DJ  
BISHOP POINT LIVING SHORELINE  
FEBRUARY 9, 2026

Manatee County BCC  
Procurement Division  
1112 Manatee Avenue West, 7th Floor, Suite 705  
Bradenton, FL 34205  
[purchasing@mymanatee.org](mailto:purchasing@mymanatee.org)



**ADVERTISEMENT  
REQUEST FOR PROPOSALS No. 26-R089352DJ  
BISHOP POINT LIVING SHORELINE**

Manatee County, a political subdivision of the State of Florida (hereinafter referred to as County) will receive proposals from individuals, corporations, partnerships, and other legal entities authorized to do business in the State of Florida (Proposers), to provide Bishop Point Living Shoreline, as specified in this Request for Proposals.

**DATE, TIME, AND PLACE DUE**

The Due Date and Time for submission of Proposals in response to this RFP is **March 19, 2026 at 11:00 A.M. ET.** Proposals must be delivered to the following location: Manatee County Administration Building, 1112 Manatee Avenue West, 7th Floor, Suite 705, Bradenton, FL 34205 prior to the Due Date and Time.

**SOLICITATION INFORMATION CONFERENCE**

There is no Solicitation Information Conference for this Request for Proposals.

**DEADLINE FOR QUESTIONS AND CLARIFICATION REQUESTS**

The deadline to submit all questions, inquiries, or requests concerning interpretation, clarification or additional information pertaining to this Request for Proposal to the Manatee County Procurement Division is **February 25, 2026, 5:00 P.M. ET.** Questions and inquiries should be submitted via email to the Designated Procurement Contact shown below.

**Important: A prohibition of lobbying is in place. Review Section A.13 carefully to avoid violation and possible sanctions.**

**DESIGNATED PROCUREMENT CONTACT:** Dave Janney, Procurement Agent III

(941) 749-3056, Fax (941) 749-3034  
Email: [Dave.Janney@mymanatee.org](mailto:Dave.Janney@mymanatee.org)  
Manatee County Financial Management Department  
Procurement Division

AUTHORIZED FOR RELEASE:

## TABLE OF CONTENTS

<b>SECTION</b>		<b>Page</b>
A	Instructions to Proposers	4
B	Evaluation of Proposals	18
C	Negotiation of the Agreement	20

### **SECTION D, FORMS** (to be executed and return with the Proposal)

Form 1	Acknowledgement of Addenda
Form 2	Proposal Signature Form
Form 3	Public Contracting and Environmental Crimes Certification
Form 4	Conflict of Interest Disclosure Form
Form 5	Non-Collusion Affidavit
Form 6	Truth-in Negotiation Certificate
Form 7	Scrutinized Company Certification
Form 8	Insurance Statement
Form 9	Indemnity and Hold Harmless
Form 10	Anti-Human Trafficking Affidavit

### **SECTION E, EXHIBITS**

Exhibit 1	Scope of Services
Exhibit 2	Proposal Response
Exhibit 3	Bid Pricing Form
Exhibit 4	Plans
Exhibit 5	Technical Specifications
Exhibit 6	FDEP Permit
Exhibit 7	US Army Corp. Permit
Exhibit 8	Grant Agreement
Exhibit 9	Grant Terms and Conditions
Exhibit 10	Federal Funding Compliance Addendum
Exhibit 11	Sample Agreement

## **SECTION A, INSTRUCTIONS TO PROPOSERS**

In order to receive consideration, Proposers must meet the minimum qualification requirements and comply with the following instructions. Proposals will be accepted from a single business entity, joint venture, partnership, or corporation.

### **A.01 INFORMATION CONFERENCE**

There is no Solicitation Information Conference scheduled for this Request for Proposal.

### **A.02 PROPOSAL DUE DATE**

The Due Date and Time for submission of Proposals in response to this Request for Proposals (RFP) is **March 19, 2026, at 11:00 A.M. ET**. Proposals must be delivered to the following location: Manatee County Administration Building, 1112 Manatee Ave. W., 7th Floor, Suite 705, Bradenton, FL 34205 and be time stamped by a Procurement representative prior to the Due Date and Time. Proposals will be opened immediately following the Due Date and Time at the Manatee County Administration Building, 7th Floor, Suite 705.

Proposal(s) received after the Due Date and Time will not be considered. It will be the sole responsibility of the Proposer to deliver its proposal to the Manatee County Procurement Division for receipt on or before the Due Date and Time. If a proposal is sent by U.S. Mail, courier or other delivery services, the Proposer will be responsible for its timely delivery to the Procurement Division. Proposals delayed in delivery will not be considered, will not be opened at the public opening, and arrangements will be made for their return at the Proposer's request and expense.

### **A.03 PUBLIC OPENING OF PROPOSALS**

Sealed Proposals will be publicly opened at Manatee County Administration Procurement Division, 1112 Manatee Avenue West, 7th Floor, Suite 705, Bradenton, Florida 34205, in the presence of County officials immediately upon expiration of the Due Date and Time.

Manatee County will make public the names of the business entities which submitted a proposal and city and state in which they reside at the opening. No review or analysis of the proposals will be conducted at the proposal opening.

### **A.04 SUBMISSION OF PROPOSALS**

The contents of the proposal sealed package must include:

- One (1) bound original clearly identifying Proposer and marked "ORIGINAL".
- Three (3) bound copies clearly identifying Proposer and marked "COPY" with all required information and identical to the original.
- One (1) electronic format copy(s) clearly identifying Proposer.

Electronic format copies should be submitted on separate Universal Serial Bus (USB) portable flash memory drives or compact disc (CD) in Microsoft Office® or Adobe Acrobat® portable document format (PDF) **in one file that includes all required TAB sections shown in Exhibit 2 in a continuous file. Do not** submit electronic format proposal with separate files for each TAB section. **Do not** password protect or otherwise encrypt electronic proposal copies. Electronic copies must contain an identical proposal to the “ORIGINAL”.

Submit the proposal package in a sealed container with the following information clearly marked on the outside of the package: RFP No. 26-R089352DJ, Bishop Point Living Shoreline, Proposer’s name, and Proposer’s address. Proposals must be received by the Manatee County Procurement Division prior to the Due Date and Time at the following address:

Manatee County  
Procurement Division  
1112 Manatee Avenue West, 7th Floor, Suite 705  
Bradenton, FL 34205

#### **A.05 ORGANIZATION OF PROPOSALS**

Proposals must be organized and arranged with TABS in the same order as listed in the subsections within Exhibit 2 identifying the response to each specific item.

Proposals must clearly indicate the legal name, address, and telephone number of the Proposer. Proposals must be signed by an individual authorized to make representations for the Proposer.

#### **A.06 DISTRIBUTION OF SOLICITATION DOCUMENTS**

All documents issued pursuant to this RFP are distributed electronically and available for download at no charge at [www.mymanatee.org](http://www.mymanatee.org) > *Bids and Proposals*. This link is located on the left side of the County website home page. Documents may be viewed and downloaded for printing using Adobe Reader® software. At its sole discretion, the County may utilize a third-party provider, to distribute proposals. Visit the third-party’s website for more information regarding this service. Participation in the third-party system is not a requirement for doing business with Manatee County.

Additionally, the RFP and all related documents are available for public inspection at the Manatee County Procurement Division, 1112 Manatee Avenue West, 7th Floor, Suite 705, Bradenton, FL 34205. Call (941) 749-3014 to schedule an appointment. Documents are available between the hours of 8:00 A.M. and 5:00 P.M., Monday through Friday, with the exception of County holidays.

As a courtesy, Manatee County notifies the Manatee County Chamber of Commerce and the Manasota Black Chamber of Commerce of all active solicitations, who then distributes the information to its members.

**A.07 ADDENDA**

Any interpretations, corrections or changes to this RFP will be made by addenda. Addenda will be posted on the Procurement Division's web page of the County website at <http://www.mymanatee.org/purchasing> > *Bids and Proposals*. For those solicitations that are advertised on a third-party distribution system, addenda will also be posted on the third-party distribution system on the 'Planholders' link.

All addenda are a part of the RFP, and each Proposer will be bound by such addenda. It is the responsibility of each Proposer to read and comprehend all addenda issued. Failure of any Proposer to acknowledge an issued addendum in its Proposal will not relieve the Proposer from any obligation contained therein.

**A.08 PROPOSAL EXPENSES**

All costs incurred by Proposer in responding to this RFP and to participate in any interviews/presentations/demonstrations, including travel, will be the sole responsibility of the Proposer.

**A.09 QUESTION AND CLARIFICATION PERIOD**

Each Proposer shall examine all RFP documents and will judge all matters relating to the adequacy and accuracy of such documents. Any questions or requests concerning interpretation, modification, clarification or additional information pertaining to this RFP shall be made in writing via email to the Manatee County Procurement Division to the Designated Procurement Contact or to [purchasing@mymanatee.org](mailto:purchasing@mymanatee.org). All questions received and responses given will be provided to potential Proposers via an addendum to this RFP.

If the Proposer requests modifications to the RFP documents, the Proposer must provide detailed justification for each modification requested. The County will determine what changes will be acceptable to the County and changes approved by the County will be issued in a written addendum.

Manatee County will not be responsible for oral interpretations given by other sources including County staff, representative, or others. The issuance of a written addendum by the Procurement Division is the only official method whereby interpretation, clarification or additional information will be given.

**A.10 FALSE OR MISLEADING STATEMENTS**

Proposals which contain false or misleading statements, or which provide references which do not support an attribute or condition claimed by the Proposer, may be rejected. If, in the opinion of the County, such information was intended to mislead the County in its evaluation of the proposal, and the attribute, condition or capability is a requirement of this RFP such Proposer will be disqualified from consideration for this RFP and may be disqualified from submitting a response on future solicitation opportunities with the County.

**A.11 WITHDRAWAL OR REVISION OF PROPOSALS**

Proposers may withdraw Proposals under the following circumstances:

- a. If Proposer discovers a mistake(s) prior to the Due Date and Time. Proposer may withdraw its proposal by submitting a written notice to the Procurement Division. The notice must be received in the Procurement Division prior to the Due Date and Time for receiving proposals. A copy of the request shall be retained, and the unopened proposal returned to the Proposer; or
- b. After the Proposals are opened but before a contract is signed, Proposer alleges a material mistake of fact if:
  - 1. The mistake is clearly evident in the solicitation document; or
  - 2. Proposer submits evidence which clearly and convincingly demonstrates that a mistake was made in the Proposal. Request to withdraw a Proposal must be in writing and approved by the Purchasing Official.

**A.12 JOINT VENTURES**

Proposers intending to submit a proposal as a joint venture with another entity are required to have filed proper documents with the Florida Department of Business and Professional Regulation and all other State or local licensing agencies as required by Florida Statute Section 489.119, prior to the Due Date and Time.

**A.13 LOBBYING**

After the issuance of any solicitation, no prospective Proposers, or their agents, representatives or persons acting at the request of such Proposers, shall contact, communicate with, or discuss any matter relating in any way to the solicitation with any County officers, agents or employees, other than the Purchasing Official or designee, unless otherwise directed by the Purchasing Official or designee. This prohibition includes copying such persons on written communications (including email correspondence) but does not apply to presentations made to evaluation committees or at a County Commission meeting where the Commission is considering approval of a proposed contract/purchase

order. This requirement ends upon final execution of the contract/purchase order or at the time the solicitation is cancelled. Violators of this prohibition will be subject to sanctions as provided in the Manatee County Code of Ordinances Section 2-26-31 and 2-26-32. Sanctions may include (a) written warning; (b) termination of contracts; and (c) debarment or suspension.

**A.14 EXAMINATION OF PROPOSALS**

The examination and evaluation of the proposals submitted in response to this solicitation generally requires a period of not less than ninety (90) calendar days from the Due Date and Time.

**A.15 ERRORS OR OMISSIONS**

Once a proposal is opened, the County will not accept any request by Proposer to correct errors or omissions in the proposal other than as identified in paragraph A.11.

**A.16 DETERMINATION OF RESPONSIBLENESS AND RESPONSIVENESS**

The County will conduct a due diligence review of all proposals received to determine if the Proposer is responsible and responsive.

To be responsive a Proposer must submit a proposal that conforms in all material respects to the requirements of this RFP and contains all the information, fully completed attachments and forms, and other documentation required. Proposals that are deemed non-responsive will not be considered or evaluated.

To be responsible, a Proposer must meet the minimum qualification requirements and have the capability to perform the Scope of Services contained in this RFP. Proposals submitted by Proposers that are deemed non-responsible will not be considered or evaluated.

**A.17 RESERVED RIGHTS**

The County reserves the right to accept or reject any and all proposals, to waive irregularities and technicalities, to request additional information and documentation, and to cancel this solicitation at any time prior to execution of the contract. In the event only one proposal is received, the County reserves the right to negotiate with the Proposer. The County reserves the right to award the contract to a responsive and responsible Proposer which in its sole determination is the best value and in the best interests of the County.

The County reserves the right to conduct an investigation as it deems necessary to determine the ability of any Proposer to perform the work or service requested. Upon request by the County, Proposer shall provide all such information to the County. Additional information may include, but will not be limited to, current financial



statements prepared in accordance with generally accepted accounting practices and certified by an independent CPA or official of Proposer; verification of availability of equipment and personnel; and past performance records.

**A.18 APPLICABLE LAWS**

Proposer must be authorized to transact business in the State of Florida. All applicable laws and regulations of the State of Florida and ordinances and regulations of Manatee County will apply to any resulting contract. This solicitation process will be conducted in accordance with Manatee County Code of Ordinances, Chapter 2-26.

**A.19 TAXES**

Manatee County is exempt from Federal Excise and State Sales Taxes. (F.E.T. Cert. No. 59-78-0089K; Florida Sales Tax Exempt Cert. No. 85-8012622206C-6). Therefore, the Proposer is prohibited from delineating a separate line item in its proposal for any sales or service taxes.

The successful Proposer will be responsible for the payment of taxes of any kind, including but not limited to sales, consumer, use, and other similar taxes payable on account of the work performed and/or materials furnished under the award in accordance with all applicable laws and regulations.

**A.20 SCRUTINIZED COMPANIES**

Pursuant to Florida Statute Section 287.135, as of July 1, 2012, a company that, at the time of submitting a response for a new contract or renewal of an existing contract, is on the Scrutinized Companies with Activities in Sudan List or the Scrutinized Companies with Activities in the Iran Petroleum Energy Sector List, created pursuant to Florida Statute Section 215.473, is ineligible for, and may not submit a response for or enter into or renew a contract with an agency or local governmental entity for goods or services of \$1 million or more.

**A.21 COLLUSION**

Proposer certifies that its Proposal is made without prior understanding, agreement, or connection with any other corporation, firm or person submitting a Proposal for the same materials, services, supplies, or equipment and is in all respects fair and without collusion or fraud.

Any such violation may result in contract cancellation, return of materials or discontinuation of services and the possible removal of Proposer from participation in future County solicitations for a specified period.

The County reserves the right to disqualify a Proposer during any phase of the solicitation process and terminate for cause any resulting contract upon evidence of collusion with intent to defraud on the part of the Proposer.

**A.22 CODE OF ETHICS**

With respect to this proposal, if any Proposer violates, directly or indirectly, the ethics provisions of the Manatee County Procurement Code and/or Florida criminal or civil laws related to public procurement, including but not limited to Florida Statutes Chapter 112, Part II, Code of Ethics for Public Officers and Employees, such Proposer will be disqualified from eligibility to perform the work described in this RFP, and may also be disqualified from submitting any future bids or proposals to supply goods or services to Manatee County.

**A.23 PUBLIC ENTITY CRIMES**

In accordance with Section 287.133, Florida Statutes, a person or affiliate who has been placed on the convicted vendor list following a conviction for a public entity crime may not submit a proposal on a contract to provide any goods or services to a public entity, may not submit a proposal on a contract with a public entity for the construction or repair of a public building or public work, may not submit proposals on leases or real property to a public entity, may not be awarded or perform work as a contractor, subcontractor, or consultant under a contract with any public entity, and may not transact business with any public entity in excess of the threshold amount provided in Section 287.017 for Category Two for a period of 36 months from the date of being placed on the convicted vendor list.

In addition, Manatee County Code of Laws Chapter 2-26 Article V prohibits the award of County contracts to any person or entity who/which has, within the past 5 years, been convicted of, or admitted to in court or sworn to under oath, a public entity crime or of any environmental law that, in the reasonable opinion of the Purchasing Official, establishes reasonable grounds to believe the person or business entity will not conduct business in a reasonable manner.

To ensure compliance with the foregoing, Manatee County Code of Laws requires all persons or entities desiring to contract with Manatee County to execute and file with the Purchasing Official an affidavit, executed under the pain and penalties of perjury, confirming that person, entity, and any person(s) affiliated with the entity, does not have such a record and is therefore eligible to seek and be awarded business with Manatee County. Proposer is to complete Form 3 and submit with its Proposal.

**A.24 AMERICANS WITH DISABILITIES**

Manatee County does not discriminate upon the basis of any individual's disability status. This non-discrimination policy involves every aspect of County's functions including

one's access to participation, employment, or treatment in its programs or activities. Anyone requiring reasonable accommodation for an information conference or proposal opening should contact the person named on the cover page of this document at least twenty-four (24) hours in advance of either activity.

**A.25 EQUAL EMPLOYMENT OPPORTUNITY**

In accordance with Title VI of the Civil Rights Act of 1964, Title 15, Part 8 of the Code of Federal Regulations and the Civil Rights Act of 1992, Manatee County hereby notifies all Proposers that it will affirmatively ensure minority business enterprises are afforded full opportunity to participate in response to this Request For Proposal and will not be discriminated against on the grounds of race, color, national origin, religion, sex, age, handicap, or marital status in consideration of award.

**A.26 MINORITY AND/OR DISADVANTAGED BUSINESS ENTERPRISE**

The State of Florida Office of Successful Proposer Diversity provides the certification process and maintains the database of certified MBE/DBE firms. Additional information may be obtained at <http://www.osd.dms.state.fl.us/iframe.htm> or by calling (850) 487-0915.

**A.27 DISCLOSURE**

Upon receipt, all inquiries and responses to inquiries related to this Request for Proposal become "Public Records" and shall be subject to public disclosure consistent with Florida Statute, Chapter 119.

Proposals become subject to disclosure thirty (30) days after the opening or if a notice of intent to award decision is made earlier than this time as provided by Florida Statutes § 119.071(1)(b). No announcement or review of the proposals shall be conducted at the public opening.

If County rejects all proposals and concurrently notices its intent to reissue the solicitation, the rejected proposals are exempt from public disclosure until such time the County provides notice of an intended decision concerning the reissued solicitation or until County withdraws the reissued solicitation. A proposal is not exempt for longer than twelve (12) months after the initial notice of rejection of all proposals.

Pursuant to Florida Statute 119.0701, to the extent successful Proposer is performing services on behalf of County, successful Proposer must:

- a. Keep and maintain public records required by public agency to perform the service. That information and data it manages as part of the services may be public record in accordance with Chapter 119, Florida Statutes and Manatee County public record policies. Proposer agrees, prior to providing goods/services, it will implement policies

and procedures, which are subject to approval by County, to maintain, produce, secure, and retain public records in accordance with applicable laws, regulations, and County policies including but not limited to Section 119.0701, Florida Statutes.

- b. Upon request from the public agency's custodian of public records, provide the public agency with a copy of the requested records or allow the records to be inspected or copied within a reasonable time at a cost that does not exceed the cost provided in Florida Statutes, Chapter 119, or as otherwise provided by law.
- c. Ensure that public records that are exempt or confidential and exempt from public records disclosure requirements are not disclosed except as authorized by law for the duration of the contract term and following completion of the contract if the successful Proposer does not transfer the records to the public agency.
- d. Upon completion of the contract, transfer, at no cost, to the public agency all public records in possession of contractor or keep and maintain public records required by the public agency to perform the service. If the successful Proposer transfers all public records to County upon completion of the contract, the successful Proposer shall destroy any duplicate public records that are exempt or confidential and exempt from public records disclosure requirements. If the successful Proposer keeps and maintains public records upon completion of the contract, the successful Proposer shall meet all applicable requirements for retaining public records. All records stored electronically must be provided to County, upon request from County's custodian of public records, in a format that is compatible with the information technology systems of County.

**IF THE SUCCESSFUL PROPOSER HAS QUESTIONS REGARDING THE APPLICATION OF CHAPTER 119, FLORIDA STATUTES, TO ITS DUTY TO PROVIDE PUBLIC RECORDS RELATING TO ANY RESULTING CONTRACT, CONTACT COUNTY'S CUSTODIAN OF PUBLIC RECORDS AT:**

**PHONE: (941) 742-5845**

**EMAIL: [LACY.PRITCHARD@MYMANATEE.ORG](mailto:LACY.PRITCHARD@MYMANATEE.ORG)**

**ATTN: RECORDS MANAGER**

**1112 MANATEE AVENUE WEST**

**BRADENTON, FL 34205**

#### **A.28 TRADE SECRETS**

Manatee County is subject to Chapter 119, Florida Statutes. Therefore, all documents, materials, and data submitted as part of a Proposal in response to a Request for Proposal

are governed by the disclosure, exemption and confidentiality provisions relating to public records in Florida Statutes.

**Notwithstanding any other provision in this solicitation, designation of the entire proposal as trade secret, proprietary, or confidential, is not permitted and may result in a determination that the Proposal is non-responsive and therefore the proposal will not be evaluated or considered.**

Except for materials that are ‘**trade secrets**’ as defined by Chapter 812, Florida Statutes, ownership of all documents, materials and data submitted as part of a Proposal in response to the Request for Proposal shall belong exclusively to County.

To the extent that Proposer desires to maintain the confidentiality of materials that constitute trade secrets pursuant to Florida law, trade secret material submitted must be segregated from the portions of the Proposal that are not declared as trade secret. In addition, Proposer shall cite, for each trade secret claimed, the Florida Statute number which supports the designation. Further, Proposer must offer a brief written explanation as to why the cited Statute is applicable to the information claimed as trade secret.

Additionally, Proposer shall provide a hard copy of its Proposal that redacts all information designated as trade secret.

In conjunction with trade secret designation, Proposer acknowledges and agrees that:

- a. Trade secret requests made after the opening will not be considered. However, County reserves the right to clarify the Proposers request for trade secret at any time; and
- b. County and its officials, employees, agents, and representatives are hereby granted full rights to access, view, consider, and discuss the information designated as trade secret throughout the evaluation process and until final execution of any awarded purchase order or contract; and
- c. That after notice from County that a public records request has been made pursuant to Proposer’s proposal, the Proposer at its sole expense, shall be responsible for defending its determination that submitted material is a trade secret and is not subject to disclosure. Action by Proposer in response to notice from the County shall be taken immediately, but no later than 10 calendar days from the date of notification or Proposer will be deemed to have waived the trade secret designation of the materials.

Proposer shall indemnify and hold County, and its officials, employees, agents, and representatives harmless from any actions, damages (including attorney’s fees and costs), or claims arising from or related to the designation of trade secrets by the Proposer, including actions or claims arising from County’s non-disclosure of the trade secret materials.

## **A.29 CONFIDENTIALITY OF SECURITY RELATED RECORDS**

- a. Pursuant to Florida Statutes § 119.071(3), the following records (hereinafter referred to collectively as “the Confidential Security Records”) are confidential and exempt from the disclosure requirements of Florida Statutes § 119.07(1):
  - i. A Security System Plan or portion thereof for any property owned by or leased to County or any privately owned or leased property held by County.
  - ii. Building plans, blueprints, schematic drawings, and diagrams, including draft, preliminary, and final formats, which depict the internal layout and structural elements of a building, arena, stadium, water treatment facility, or other structure owned or operated by County.
  - iii. Building plans, blueprints, schematic drawings, and diagrams, including draft, preliminary, and final formats, which depict the internal layout or structural elements of an attractions and recreation facility, entertainment or resort complex, industrial complex, retail and service development, office development, or hotel or motel development in the possession of, submitted to County.
- b. Successful Proposer agrees that, as provided by Florida Statute, it shall not, as a result of a public records request, or for other reason disclose the contents of, or release or provide copies of the Confidential Security Records to any other party absent the express written authorization of County’s Property Management Director or to comply with a court order requiring such release or disclosure. To the extent successful Proposer receives a request for such records, it shall immediately contact the County’s designated Contract administrator who shall coordinate County’s response to the request.

## **A.30 E-VERIFY**

Prior to the employment of any person under this contract, the successful Proposer shall utilize the U.S. Department of Homeland Security’s E-Verify system to verify the employment eligibility of (a) all persons employed during the contract term by the successful Proposer to perform employment duties within Florida and (b) all persons, including subcontractors, assigned by the successful Proposer to perform work pursuant to the contract with Manatee County. For more information on this process, please refer to United States Citizenship and Immigration Service site at: <http://www.uscis.gov/>. Only those individuals determined eligible to work in the United States shall be employed under this contract.

By submission of a proposal in response to this RFP, the successful Proposer commits that all employees and subcontractors will undergo e-verification before placement on this contract.

The successful Proposer shall maintain sole responsibility for the actions of its employees and subcontractors. For the life of the contract, all employees and new employees brought in after contract award shall be verified under the same requirement stated above.

**A.31 LICENSES AND PERMITS**

The successful Proposer shall be solely responsible for obtaining all necessary license and permit fees, including, but not limited to, all license fees, permit fees, impact fees, or inspection fees, and responsible for the costs of such fees. Successful Proposer is solely responsible for ensuring all work complies with all Federal, State, local, and Manatee County ordinances, orders, codes, laws, rules, regulations, directives, and guidelines.

**A.32 PROHIBITION AGAINST CONSIDERING SOCIAL, POLITICAL, OR IDEOLOGICAL INTERESTS IN GOVERNMENT CONTRACTS**

This section shall serve as notification that this solicitation is in accordance with Florida Statutes Chapter 287.05701.

**A.33 HEALTH INSURANCE PORTABILITY AND ACCOUNTABILITY ACT (HIPAA)**

Any person or entity that performs or assists the County with a function or activity involving the use or disclosure of “individually identifiable health information (IIHI) and/or Protected Health Information (PHI) shall comply with the Health Insurance Portability and Accountability Act (HIPAA) of 1996. HIPAA mandates for privacy, security, and electronic transfer standards include, but are not limited to:

- a. Use of information only for performing services required by the contract or as required by law;
- b. Use of appropriate safeguards to prevent non-permitted disclosures;
- c. Reporting to the County any non-permitted use or disclosure;
- d. Assurances that any agents and subcontractors agree to the same restrictions and conditions that apply to the Proposer and reasonable assurances that IIHI/PHI will be held confidential;
- e. Making PHI available to the customer;
- f. Making PHI available to the customer for review and amendment, and incorporating any amendments requested by the customer;
- g. Making PHI available to the County for an accounting of disclosures; and making internal practices, books, and records related to PHI available to the County for compliance audits.

PHI shall maintain its protected status regardless of the form and method of transmission (paper records and/or electronic transfer of data). The selected Proposer must give its customers written notice of its privacy information practices, including specifically, a description of the types of uses and disclosures that would be made with protected health information.

#### **A.34 BINDING OFFER**

Proposals will remain valid for a period of 120 days following the Due Date and Time and will be considered a binding offer to perform the required services and/or provide the required goods. The submission of a Proposal will be taken as prima facie evidence that the Proposer has familiarized itself with the contents of this Solicitation.

#### **A.35 PROTEST**

Any actual bidder, proposer, or contractor who is aggrieved in connection with the notice of intent to award of a contract with a value greater than \$250,000 where such grievance is asserted to be the result of a violation of the requirements of the Manatee County Procurement Code or any applicable provision of law by the officers, agents, or employees of the County, may file a protest to the Purchasing Official.

Protest must be in writing and delivered via email at [purchasing@mymanatee.org](mailto:purchasing@mymanatee.org) or by hand delivery to the Procurement Division at 1112 Manatee Avenue West, 7th Floor, Suite 705, Bradenton, FL 34205 by 5:00 p.m. on the fifth business day following the date of posting of the Notice of Intent to Award on the County website. There is no stay of the procurement process during a protest. The Purchasing Official shall have the authority to settle and resolve a protest concerning the intended award of a contract.

For additional information regarding the County protest process, visit the Procurement Division webpage on the County website.

#### **A.36 ACCESSIBILITY**

The County is committed to making its documents and information technologies accessible to individuals with disabilities by meeting the requirements of Section 508 of the Rehabilitation Act and best practices (W3C WCAG 2). **For assistance with accessibility regarding this solicitation, contact the Manatee County Procurement Division via email at [purchasing@mymanatee.org](mailto:purchasing@mymanatee.org) or by phone at 941-748-4501, X3014.**

Successful Proposer shall ensure all its electronic information, documents, applications, reports, and deliverables required in the proposal are in a format that meets the requirements of Section 508 of the Rehabilitation Act and best practices (W3C WCAG 2).

Where not fully compliant with these requirements and best practices, Successful Proposer shall provide clear points of contact for each document and information technology to direct users in how to obtain alternate formats. Further, successful Proposer shall develop accommodation strategies for those non-compliant resources and implement strategies to resolve the discrepancies.



**A.37 PROJECTED SOLICITATION SCHEDULE**

The following projected solicitation schedule has been established for this Solicitation process. Refer to the County’s website ([www.mymanatee.org](http://www.mymanatee.org) > *Business* > *Bids & Proposals*) for meeting locations and updated information pertaining to any revisions to this schedule.

<b>Scheduled Item</b>	<b>Scheduled Date</b>
No Information Conference has been scheduled for this solicitation	N/A
Question and Clarification Deadline	February 25, 2026
Proposal Due Date and Time	March 19, 2026, by 11:00 A.M., ET
Technical Evaluation Meeting	TBD
Technical Evaluation Meeting	TBD
Interviews/Demonstrations/Presentations, if conducted	TBD
Final Technical Evaluations	TBD
Projected Award	May 2026

The purpose of the Solicitation Schedule is to provide a projected timeline of solicitation events. The County reserves the right to modify or change any of the projected dates and times.

**END SECTION A**

## SECTION B, EVALUATION OF PROPOSALS

### B.01 EVALUATION

Evaluation of proposals will be conducted by an evaluation committee. Each evaluation committee member will evaluate and score the proposals for each of the evaluation criteria.

The committee reserves the right to provide a final score without conducting interviews, presentations, and/or demonstrations with Proposers. Therefore, each Proposer must ensure that its proposal contains all the information requested in this RFP and reflects Proposer's best offer.

The committee will consider all information submitted by each responsible and responsive Proposer, clarification information provided by Proposer, information obtained during the interview/presentation/demonstration, feedback received from Proposer's references, and any other relevant information received during any investigation of Proposer, to ascertain the ability of the Proposer(s) to perform the scope of services as stated in this RFP.

### B.02 EVALUATION CRITERIA

The following evaluation criteria have been established for this RFP.

<b>Criteria</b>	<b>Maximum Score</b>
Proposer & Team's Experience	20
Approach	25
Capacity	20
Similar Completed Projects	25
Fee Proposal	10

### B.03 CLARIFICATIONS/INTERVIEWS /PRESENTATIONS/ DEMONSTRATIONS

As part of the evaluation process the evaluation committee may request additional information or clarification from Proposers for the purpose of further evaluation of (a) conformance to the solicitation requirements, (b) the abilities of the Proposer, and (c) understanding of the proposal submitted. Additional information and/or clarification must be submitted by Proposer within the requested time-period.

Additionally, interviews, presentations and/or demonstrations may be conducted with Proposers as part of the evaluation process. If conducted, the evaluation committee will make a determination of those proposals that are deemed by the committee as having a

reasonable probability of being selected for award. The Proposers for this ‘short-list’ of proposals will be invited to meet with the committee. Proposers shall make arrangements to attend the interviews, presentations and/or demonstrations if invited. The interviews, presentations and/or demonstrations are closed to the public to the extent permitted by law.

The committee reserves the right to provide a final score without conducting interviews, presentations, and/or demonstrations with Proposers. Therefore, each Proposer must ensure that its proposal contains all the information requested in this RFP and reflects Proposer’s best offer.

**B.04 BEST AND FINAL OFFER (BAFO)**

The County may request a BAFO if additional information or modified proposals are necessary for the evaluation committee to complete its evaluation and scoring. The information received from the BAFO will be used by the evaluation committee to re-evaluate and re-score the Proposers.

**B.05 SCORING OF PROPOSALS**

The evaluation committee will determine from the responses to this RFP and subsequent investigation as necessary, the Proposer(s) whose proposal(s) best meet the County’s requirements and recommend the County enter into negotiations for an agreement.

In its review, the evaluation committee may take the following actions:

- a. Review all responses pursuant to the evaluation factors stated herein.
- b. Short list Proposers to be further considered in written or oral interview/presentation/product demonstrations.
- c. Recommend commencement of negotiations to the Purchasing Official.
- d. Reject all proposals received and cancel the Request for Proposal.
- e. Receive written clarification of proposal.

**END SECTION B**

## **SECTION C, NEGOTIATION OF THE AGREEMENT**

### **C.01 GENERAL**

- a. The proposal will serve as a basis for negotiating an agreement.
- b. Upon submission, all proposals become the property of Manatee County which has the right to use any or all ideas presented in any proposal submitted in response to this Request for Proposal whether, or not, the proposal is accepted.
- c. All products and papers produced by Proposer and submitted to the County during the solicitation process become the property of Manatee County.

### **C.02 NEGOTIATION**

The evaluation committee will make a recommendation as to the Proposer which the County should enter into negotiations, if any. Upon approval of the recommendation, the successful Proposer will be invited to enter negotiations led by the County Procurement Division. These negotiations are generally relative to the scope of work/services to be provided and any associated costs.

The County will publicly notice the Intent to Negotiate prior to commencing negotiations as required by law and policy.

### **C.03 RECOMMENDATION FOR AWARD**

Upon successful completion of negotiations, a recommendation for award to the successful Proposer(s) will be presented for approval per County ordinances, policies, and procedures.

### **C.04 AGREEMENT**

The successful Proposer(s) will be required to enter into an agreement. Agreement may, or may not, include all elements of this RFP or the resulting successful Proposer's Proposal where alternatives provide best value, are desirable to the County, and the parties agree to such terms.

### **C.05 AWARD**

The County does not make award to a Proposer who is delinquent in payment of any taxes, fees, fines, contractual debts, judgments, or any other debts due and owed to County, or is in default on any contractual or regulatory obligation to County. By submitting this solicitation response, Proposer attests that it is not delinquent in payment of any such debts due and owed to County, nor is it in default on any contractual or regulatory obligation to County. In the event the Proposer's statement is discovered to be false, Proposer will be subject to suspension and/or debarment and County may terminate any contract it has with Proposer.

Award of an agreement is subject to the approval of either the Purchasing Official or the Board of County Commissioners, as provided for in the current Manatee County Procurement Code.

**END SECTION C**

**FORM 1 - ACKNOWLEDGMENT OF ADDENDA**  
**RFP No. 26-R089352DJ**

The undersigned acknowledges receipt of the following addenda:

Addendum No. _____	Date Received:
Addendum No. _____	Date Received:
Addendum No. _____	Date Received:
Addendum No. _____	Date Received:
Addendum No. _____	Date Received:
Addendum No. _____	Date Received:
Addendum No. _____	Date Received:
Addendum No. _____	Date Received:
Addendum No. _____	Date Received:

Print or type Proposer's information below:

_____	_____
Name of Proposer	Telephone Number
_____	_____
Street Address	City/State/Zip
_____	_____
Email Address	Website Address
_____	_____
Print Name & Title of Authorized Officer	Signature of Authorized Official and Date

**Return this fully executed form with your Proposal.**

**FORM 2 - PROPOSAL SIGNATURE FORM**  
**RFP No. 26-R089352DJ**

The undersigned represents that by signing this Proposal Signature Form that:

- (1) He/she has the authority and approval of the legal entity purporting to submit the Proposal and any additional documentation which may be required such as the Joint Venture Agreement or Joint Venture Affidavit, if applicable; and
- (2) All facts and responses set forth in the Proposal are true and correct; and
- (3) If the Proposer is selected by County to negotiate an agreement, that Proposer's negotiators will negotiate in good faith to establish an agreement to provide the services described in this RFP; and
- (4) By submitting a Proposal and signing below, the Proposer agrees to the terms and conditions in this RFP, which incorporates all addenda, appendices, exhibits, and attachments, in its entirety, and is prepared to sign the Agreement, of which a sample is incorporated into this RFP as Exhibit 3. The Proposer understands that if it submits exceptions to the Sample Agreement in its Proposal, the Proposer may be determined non-responsive.

Print or type Proposer's information below:

_____	_____
Name of Proposer	Telephone Number
_____	_____
Street Address	City/State/Zip
_____	_____
Email Address	Web Address
_____	_____
Print Name & Title of Authorized Officer	Signature of Authorized Officer      Date

**Return this fully executed form with your Proposal.**

**FORM 3 - PUBLIC CONTRACTING AND ENVIRONMENTAL CRIMES  
CERTIFICATION  
RFP No. 26-R089352DJ**

SWORN STATEMENT PURSUANT TO MANATEE COUNTY PROCUREMENT CODE  
SECTION 2-26 ARTICLE V,

THIS FORM MUST BE SIGNED AND SWORN TO IN THE PRESENCE OF A NOTARY  
PUBLIC OR OTHER OFFICIAL AUTHORIZED TO ADMINISTER OATHS.

This sworn statement is submitted to Manatee County by \_\_\_\_\_  
\_\_\_\_\_ [print individual's name and title]

for \_\_\_\_\_  
\_\_\_\_\_ [name of entity submitting sworn statement]

whose business address is: \_\_\_\_\_

and (if applicable) its Federal Employer Identification Number (FEIN) is \_\_\_\_\_.

If the entity has no FEIN, include the Social Security Number of the individual signing this sworn  
statement:

I, the undersigned, understand that no person or entity shall be awarded or receive a County  
contract for public improvements, procurement of goods or services (including  
professional services) or a county lease, franchise, concession, or management agreement,  
or shall receive a grant of County monies unless such person or entity has submitted a  
written certification to County that it has not:

(1) been convicted of bribery or attempting to bribe a public officer or employee of  
Manatee County, the State of Florida, or any other public entity, including, but not limited  
to the Government of the United States, any state, or any local government authority in the  
United States, in that officer's or employee's official capacity; or

(2) been convicted of an agreement or collusion among Proposers or prospective Proposers  
in restraint of freedom of competition, by agreement to bid a fixed price, or otherwise; or

(3) been convicted of a violation of an environmental law that, as determined by the  
County, reflects negatively upon the ability of the person or entity to conduct business in a  
responsible manner; or

(4) made an admission of guilt of such conduct described in items (1), (2) or (3) above,  
which is a matter of record, but has not been prosecuted for such conduct, or has made an  
admission of guilt of such conduct, which is a matter of record, pursuant to formal  
prosecution. An admission of guilt shall be construed to include a plea of nolo contendere;  
or

(5) where an officer, official, agent or employee of a business entity has been convicted of, or has admitted guilt to, any of the crimes set forth above on behalf of such and entity and pursuant to the direction or authorization of an official thereof (including the person committing the offense, if he/she is an official of the business entity), the business shall be chargeable with the conduct herein above set forth. A business entity shall be chargeable with the conduct of an affiliated entity, whether wholly owned, partially owned, or one which has common ownership or a common board of directors.

For purposes of this Form, business entities are affiliated if, directly or indirectly, one business entity controls or has the power to control another business entity, or if an individual or group of individuals controls or has the power to control both entities. Indicia of control shall include, without limitation, interlocking management or ownership, identity of interests amount family members, shared organization of a business entity following the ineligibility of a business entity under this Article, or using substantially the same management, ownership or principles as the ineligible entity.

Any person or entity who claims that this Article is inapplicable to him/her/it because a conviction or judgment has been reversed by a court of competent jurisdiction, shall prove the same with documentation satisfactory to Manatee County's Purchasing Official. Upon presentation of such satisfactory proof, the person or entity shall be allowed to contract with Manatee County.

**I UNDERSTAND THAT ANY CONTRACT OR BUSINESS TRANSACTION SHALL PROVIDE FOR SUSPENSION OF PAYMENTS, OR TERMINATION, OR BOTH, IF THE PROCUREMENT DIVISION OR THE COUNTY ADMINISTRATOR DETERMINES THAT SUCH PERSON OR ENTITY HAS MADE FALSE CERTIFICATION.**

\_\_\_\_\_  
Signature of Contractor Representative

STATE OF \_\_\_\_\_

COUNTY OF \_\_\_\_\_

Sworn to and subscribed before me this \_\_\_\_\_ day of \_\_\_\_\_, 20\_\_\_\_\_

by \_\_\_\_\_.

Personally known    OR     Produced the following identification.

\_\_\_\_\_  
[Type of identification]

\_\_\_\_\_  
Notary Public Signature

My commission expires: \_\_\_\_\_



---

[Print, type or stamp Commissioned name of Notary Public]

**Signatory Requirement** - In the case of a business entity other than a partnership or a corporation, this affidavit shall be executed by an authorized agent of the entity. In the case of a partnership, this affidavit shall be executed by the general partner(s). In the case of a corporation, this affidavit shall be executed by the corporate president.

**Return this fully executed form with your Proposal.**

**FORM 4 - CONFLICT OF INTEREST DISCLOSURE FORM**  
**RFP No. 26-R089352DJ**

The award of an agreement resulting from this RFP is subject to the provisions of Manatee County Code of Laws. Proposer must disclose within its Proposal: the name of any officer, director, or agent who is also an employee of Manatee County. Furthermore, Proposer must disclose the name of any County employee who owns, directly or indirectly, an interest of more than five percent (5%) in the Proposer's firm or any of its branches, divisions, or affiliates.

By signing below, Proposer confirms that it is not currently engaged or will not become engaged in any obligations, undertakings or contracts that will require the firm to maintain an adversarial role against the County or that will impair or influence the advice or recommendations it provides to the County.

Please check one of the following statements and attach additional documentation if necessary:

\_\_\_\_\_ To the best of my knowledge, the undersigned firm has no potential conflict of interest for this RFP.

\_\_\_\_\_ The undersigned firm, by execution of this form, submits information which may be a potential conflict of interest for this RFP.

Acknowledged and attested to by:

\_\_\_\_\_  
Firm Name

\_\_\_\_\_  
Signature

\_\_\_\_\_  
Name and Title (Print or Type)

\_\_\_\_\_  
Date

**Return this fully executed form with your Proposal.**

**FORM 5 - NON-COLLUSION AFFIDAVIT**  
**RFP No. 26-R089352DJ**

STATE OF \_\_\_\_\_

COUNTY OF \_\_\_\_\_

Before me, the undersigned authority, personally appeared \_\_\_\_\_, who, after being by me first duly sworn, deposes and says of his/her personal knowledge that:

a. He/She is \_\_\_\_\_ of \_\_\_\_\_, the Proposer that has submitted a Proposal to perform work for the following:

RFP No.: \_\_\_\_\_ Title: \_\_\_\_\_

b. He/She is fully informed respecting the preparation and contents of the attached Request for Qualifications, and of all pertinent circumstances respecting such Solicitation.

Such Proposal is genuine and is not a collusive or sham Proposal.

c. Neither the said Proposer nor any of its officers, partners, owners, agents, representatives, employees, or parties in interest, including this affiant, has in any way colluded, conspired, connived, or agreed, directly or indirectly, with any other Proposer, firm, or person to submit a collusive or sham Proposal in connection with the Solicitation and contract for which the attached Proposal has been submitted or to refrain from proposing in connection with such Solicitation and contract, or has in any manner, directly or indirectly, sought by agreement or collusion or communication or conference with any other Proposer, firm, or person to fix the price or prices in the attached Proposal or any other Proposer, or to fix any overhead, profit, or cost element of the Proposal price or the Proposal price of any other Proposer, or to secure through any collusion, conspiracy, connivance, or unlawful agreement any advantage against the City or any person interested in the proposed contract.

d. The price or prices to be submitted shall be fair and proper and shall not be tainted by any collusion, conspiracy, connivance, or unlawful agreement on the part of the Proposer or any of its agents, representatives, owners, employees, or parties in interest, including this affiant.

Signature: \_\_\_\_\_

Subscribed and sworn to (or affirmed) before me this \_\_\_\_\_ day of \_\_\_\_\_ 20 \_\_, by \_\_\_\_\_, who is personally known to me OR has produced \_\_\_\_\_ as identification.

Notary Signature \_\_\_\_\_

Notary Name: \_\_\_\_\_

Notary Public (State): \_\_\_\_\_

My Commission Number: \_\_\_\_\_

Expires on: \_\_\_\_\_

SEAL

**Return this fully executed form with your Proposal.**

**FORM 6 - TRUTH – IN – NEGOTIATION CERTIFICATE**  
**RFP No. 26-R089352DJ**

The undersigned warrants (i) that it has not employed or retained any company or person, other than bona fide employees working solely for the undersigned, to solicit or secure the Agreement and (ii) that it has not paid or agreed to pay any person, company, corporation, individual, or firm other than its bona fide employees working solely for the undersigned or agreed to pay any fee, commission, percentage, gift, or any other consideration contingent upon or resulting from the award or making of the Agreement.

The undersigned certifies that the wage rates and other factual unit costs used to determine the compensation provided for in the Agreement are accurate, complete, and current as of the date of the Agreement.

(This document must be executed by an authorized official of Proposer (e.g., President, CEO, Partner, Managing Partner))

Name: \_\_\_\_\_

Title: \_\_\_\_\_

Date: \_\_\_\_\_

Signature: \_\_\_\_\_

**Return this fully executed form with your Proposal.**

**FORM 7 – SCRUTINIZED COMPANY CERTIFICATION**  
**RFP No. 26-R089352DJ**

This certification is required pursuant to Florida State Statute Section 287.135 and must be executed and returned with Proposer’s Proposal.

As of July 1, 2011, a company that, at the time of bidding or submitting a Proposal for a new contract or renewal of an existing contract, is on the Scrutinized Companies with Activities in Sudan List or the Scrutinized Companies with Activities in the Iran Petroleum Energy Sector List is ineligible for, and may not bid on, submit a Proposal for, or enter into or renew a contract with an agency or local governmental entity for goods or services of \$1 million or more.

Companies must complete and return this form with its response.

Company: \_\_\_\_\_

FEIN: \_\_\_\_\_

Address. \_\_\_\_\_

City/State/Zip. \_\_\_\_\_

I, \_\_\_\_\_, as a representative of \_\_\_\_\_  
certify and affirm that this entity is not on the Scrutinized Companies with Activities in Sudan List  
or the Scrutinized Companies with Activities in the Iran Petroleum Energy Sector List.

\_\_\_\_\_  
Signature

\_\_\_\_\_  
Title

\_\_\_\_\_  
Printed Name

\_\_\_\_\_  
Date

**Return this fully executed form with your Proposal.**

**FORM 8, INSURANCE REQUIREMENTS**  
**RFP No. 26-R089352DJ**

The Successful Proposer will not commence work under the resulting Agreement until all insurance coverages indicated by an “X” herein have been obtained. The Successful Proposer shall obtain and submit to the Procurement Division within ten (10) calendar days from the date of notice of intent to award, at its expense, the following minimum amounts of insurance (inclusive of any amounts provided by an umbrella or excess policy): Work under this Agreement cannot commence until all insurance coverages indicated herein have been obtained on a standard ACORD form (inclusive of any amounts provided by an umbrella or excess policy):

**Automobile Liability Insurance Required Limits**

Coverage must be afforded under a per occurrence policy form including coverage for all owned, hired and non-owned vehicles for bodily injury and property damage of not less than:

- \$1,000,000 Combined Single Limit; OR
- \$ 500,000 Bodily Injury and \$500,000 Property Damage
- \$10,000 Personal Injury Protection (No Fault)
- \$500,000 Hired, Non-Owned Liability
- \$10,000 Medical Payments

*This policy shall contain severability of interests’ provisions.*

**Commercial General Liability Insurance Required Limits (per Occurrence form only; claims-made form is not acceptable)**

Coverage shall be afforded under a per occurrence policy form, policy shall be endorsed and name ‘Manatee County, a political subdivision of the State of Florida’ as an Additional Insured, and include limits not less than:

- \$1,000,000 Single Limit Per Occurrence
- \$1,000,000 Aggregate
- \$1,000,000 Products/Completed Operations Aggregate
- \$1,000,000 Personal and Advertising Injury Liability
- \$50,000 Fire Damage Liability
- \$10,000 Medical Expense, and
- \$1,000,000, Third Party Property Damage
- \$        Project Specific Aggregate (Required on projects valued at over \$10,000,000)

*This policy shall contain severability of interests’ provisions.*

**Employer’s Liability Insurance**

Coverage limits of not less than:

- \$100,000 Each Accident
- \$100,000 Disease Each Employee
- \$500,000 Disease Policy Limit

- Worker's Compensation Insurance
- US Longshoremen & Harbor Workers Act**
- Jones Act Coverage**

Coverage limits of not less than:

- Statutory workers' compensation coverage shall apply for all employees in compliance with the laws and statutes of the State of Florida and the federal government.
- If any operations are to be undertaken on or about navigable waters, coverage must be included for the US Longshoremen & Harbor Workers Act and Jones Act.

Should 'leased employees' be retained for any part of the project or service, the employee leasing agency shall provide evidence of Workers' Compensation coverage and Employer's Liability coverage for all personnel on the worksite and in compliance with the above Workers' Compensation requirements. NOTE: Workers' Compensation coverage is a firm requirement. Elective exemptions are considered on a case-by-case basis and are approved in a very limited number of instances.

**Aircraft Liability Insurance Required Limits**

Coverage shall be afforded under a per occurrence policy form, policy shall be endorsed and name 'Manatee County a political subdivision of the State of Florida' as an Additional Insured, and include limits not less than:

- \$ Each Occurrence Property and Bodily Injury with no less than \$100,000 per passenger each occurrence or a 'smooth' limit.
- \$ General Aggregate.

**Un-Manned Aircraft Liability Insurance (Drone)**

Coverage shall be afforded under a per occurrence policy form, policy shall be endorsed and name 'Manatee County a political subdivision of the State of Florida' as an Additional Insured, and include limits not less than:

- \$ Each Occurrence Property and Bodily Injury; Coverage shall specifically include operation of Unmanned Aircraft Systems (UAS), including liability and property damage.
- \$ General Aggregate

**Installation Floater Insurance**

When the contract or agreement **does not** include construction of, or additions to, above ground building or structures, but does involve the installation of machinery or equipment, Installation Floater Insurance shall be afforded under a per occurrence policy form, policy shall be endorsed and name "Manatee County, a political subdivision of the State of Florida" as an Additional Insured, and include limits not less than:

- 100% of the completed value of such addition(s), building(s), or structure(s)

**Professional Liability and/or Errors and Omissions (E&O) Liability Insurances**

Coverage shall be afforded under either an occurrence policy form or a claims-made policy form. If the coverage form is on a claims-made basis, then coverage must be maintained for a minimum of three years from termination of date of the contract. Limits must not be less than:

- \$ 1,000,000 Bodily Injury and Property Damage Each Occurrence
- \$ 2,000,000 General Aggregate

**Builder's Risk Insurance**

When the contract or agreement includes the construction of roadways and/or the addition of a permanent structure or building, including the installation of machinery and/or equipment, Builder's Risk Insurance shall be afforded under a per occurrence policy form, policy shall be endorsed and name "Manatee County, a political subdivision of the State of Florida" as an Additional Insured, and include limits not less than:

- An amount equal to 100% of the completed value of the project, or the value of the equipment to be installed
- The policy shall not carry a self-insured retention/deductible greater than \$10,000

Coverage shall be for all risks and include, but not be limited to, storage and transport of materials, equipment, supplies of any kind whatsoever to be used on or incidental to the project, theft coverage, and Waiver of Occupancy Clause Endorsement, where applicable.

**Cyber Liability Insurance**

Coverage shall comply with Florida Statute 501.171, shall be afforded under a per occurrence policy form, policy shall be endorsed and name 'Manatee County, a political subdivision of the State of Florida' as an Additional Insured, and include limits not less than:

- \$ Security Breach Liability
- \$ Security Breach Expense Each Occurrence
- \$ Security Breach Expense Aggregate
- \$ Replacement or Restoration of Electronic Data
- \$ Extortion Threats
- \$ Business Income and Extra Expense
- \$ Public Relations Expense

NOTE: Policy must not carry a self-insured retention/deductible greater than \$25,000.

**Hazardous Materials Insurance (As Noted Below)**

Hazardous materials include all materials and substances that are currently designated or defined as hazardous by the law or rules of regulation by the State of Florida or federal government.

All coverage shall be afforded under either an occurrence policy form or a claims-made policy form, and the policy shall be endorsed and name 'Manatee County, a political subdivision of the State of Florida' as an Additional Insured. If the coverage form is on a claims-made basis, then coverage must be maintained for a minimum of three years from termination of date of the contract. Limits must not be less than:



***Pollution Liability***

Amount equal to the value of the contract, subject to a \$1,000,000 minimum, for Bodily Injury and Property Damage to include sudden and gradual release, each claim and aggregate.

***Asbestos Liability (If handling within scope of Contract)***

Amount equal to the value of the contract, subject to a \$1,000,000 minimum, for Bodily Injury and Property Damage to include sudden and gradual release, each claim and aggregate.

***Disposal***

When applicable, Successful Proposer shall designate the disposal site and furnish a Certificate of Insurance from the disposal facility for Environmental Impairment Liability Insurance covering liability.

- Amount equal to the value of the contract, subject to a \$1,000,000 minimum, for Liability for Sudden and Accidental Occurrences, each claim and an aggregate.
- Amount equal to the value of the contract, subject to a \$1,000,000 minimum, for Liability for Non-Sudden and Accidental Occurrences, each claim and an aggregate.

**Hazardous Waste Transportation Insurance**

Successful Proposer shall designate the hauler and have the hauler furnish a Certificate of Insurance for Automobile Liability insurance with Endorsement MCS-90 for liability arising out of the transportation of hazardous materials. EPA identification number shall be provided.

All coverage shall be afforded under either an occurrence policy form or a claims-made policy form and the policy shall be endorsed and name “Manatee County, a political subdivision of the State of Florida” as an Additional Insured. If the coverage form is on a claims-made basis, then coverage must be maintained for a minimum of three years from termination of date of the contract. Limits must not be less than:

- Amount equal to the value of the contract, subject to a \$1,000,000 minimum, per accident.

**Liquor Liability Insurance**

Coverage shall be afforded under a per occurrence policy form, policy shall be endorsed and name “Manatee County, a political subdivision of the State of Florida” as an Additional Insured, and include limits not less than:

- \$1,000,000 Each Occurrence and Aggregate

**Garage Keeper’s Liability Insurance**

Coverage shall be required if the maintenance, servicing, cleaning or repairing of any County motor vehicles is inherent or implied within the provision of the contract.

Coverage shall be afforded under a per occurrence policy form, policy shall be endorsed and name “Manatee County, a political subdivision of the State of Florida” as an Additional Insured, and include limits not less than:

- Property and asset coverage in the full replacement value of the lot or garage.

**Bailee’s Customer Liability Insurance**

Coverage shall be required for damage and/or destruction when County property is temporarily under the care or custody of a person or organization, including property that is on, or in transit to and from the person or organization’s premises. Perils covered should include fire, lightning, theft, burglary, robbery, explosion, collision, flood, earthquake and damage or destruction during transportation by a carrier.

Coverage shall be afforded under a per occurrence policy form, policy shall be endorsed and name “Manatee County, a political subdivision of the State of Florida” as an Additional Insured, and include limits not less than:

- Property and asset coverage in the full replacement value of the County asset(s) in the Successful Proposer’S care, custody and control.

**Hull and Watercraft Liability Insurance**

Coverage shall be afforded under a per occurrence policy form, policy shall be endorsed and name “Manatee County, a political subdivision of the State of Florida” as an Additional Insured, and include limits not less than:

- \$ Each Occurrence
- \$ General Aggregate
- \$ Fire Damage Liability
- \$10,000 Medical Expense, and
- \$ Third Party Property Damage
- \$ Project Specific Aggregate (Required on projects valued at over \$10,000,000)

**Other [Specify]**

**BOND REQUIREMENTS**

**Bid Bond**

A Bid Bond in the amount of 5% of the total offer. Bid bond shall be submitted with the sealed response and shall include project name, location, and / or address and project number. In lieu of the bond, the bidder may file an alternative form of security in the amount of 5% of the total offer. in the form of a money order, a certified check, a cashier’s check, or an irrevocable letter of credit issued to Manatee County. NOTE: A construction project over \$200,000 requires a Bid Bond in the amount of 5% of the total bid offer.

**Payment and Performance Bond**

A Payment and Performance Bond shall be submitted by Successful Bidder for 100% of the award amount and shall be presented to Manatee County within ten (10) calendar days of issuance of the notice of intent to award. NOTE: A construction project over \$200,000 requires a Payment and Performance Bond.

## INSURANCE REQUIREMENTS

### I. THE POLICIES ARE TO CONTAIN, OR BE ENDORSED TO CONTAIN, THE FOLLOWING PROVISIONS:

#### **Commercial General Liability and Automobile Liability Coverages**

- a. **“Manatee County, a Political Subdivision of the State of Florida,” is to be named as an Additional Insured in respect to:** Liability arising out of activities performed by or on behalf of the Successful Proposer, his agents, representatives, and employees; products and completed operations of the Successful Proposer; or automobiles owned, leased, hired or borrowed by the Successful Proposer. The coverage shall contain no special limitation(s) on the scope of protection afforded to the COUNTY, its officials, employees or volunteers.  
In addition to furnishing a Certificate of Insurance, the Successful Proposer shall provide the endorsement that evidences Manatee COUNTY being listed as an Additional Insured. This can be done in one of two ways: (1) an endorsement can be issued that specifically lists “Manatee County, a Political Subdivision of the State of Florida,” as Additional Insured; or, (2) an endorsement can be issued that states that all Certificate Holders are Additional Insured with respect to the policy.
- b. The Successful Proposer'S insurance coverage shall be primary insurance with respect to the COUNTY, its officials, employees and volunteers. Any insurance or self-insurance maintained by the COUNTY, its officials, employees or volunteers shall be excess of Successful Proposer's insurance and shall be non-contributory.
- c. The insurance policies must be on an occurrence form.

#### **Workers' Compensation and Employers' Liability Coverages**

The insurer shall agree to waive all rights of subrogation against the COUNTY, its officials, employees and volunteers for losses arising from work performed by the Successful Proposer for the COUNTY.

### II. General Insurance Provisions Applicable to All Policies

1. Prior to the execution of contract, or issuance of a Purchase Order, and then annually upon the anniversary date(s) of the insurance policy's renewal date(s) for as long as this contract remains in effect, Successful Proposer shall furnish the COUNTY with a Certificate(s) of Insurance (using an industry accepted certificate form, signed by the Issuer, with applicable endorsements, and containing the solicitation or contract number, and title or description) evidencing the coverage set forth above and naming “Manatee County, a Political Subdivision of the State of Florida” as an Additional Insured on the applicable coverage(s) set forth above.
2. If the policy contains an aggregate limit, confirmation is needed in writing (letter, email, etc.) that the aggregate limit has not been eroded to procurement representative when supplying Certificate of Insurance. In addition, when requested in writing from the COUNTY, Successful Proposer will provide the COUNTY with a certified copy of all applicable policies. The address where such certificates and certified policies shall be sent or delivered is as follows:

**Manatee County, a Political Subdivision of the State of Florida**  
**Attn: Risk Management Division**  
**1112 Manatee Avenue West, Suite 969**  
**Bradenton, FL 34205**

3. The project's solicitation number and title shall be listed on each certificate.
4. Successful Proposer shall provide thirty (30) days written notice to the Risk Manager of any cancellation, non-renewal, termination, material change, or reduction in coverage of any insurance policies to procurement representative including solicitation number and title with all notices.
5. Successful Proposer agrees that should at any time Successful Proposer fail to meet or maintain the required insurance coverage(s) as set forth herein, the COUNTY may terminate this contract.
6. The Successful Proposer waives all subrogation rights against COUNTY, a Political Subdivision of the State of Florida, for all losses or damages which occur during the contract and for any events occurring during the contract period, whether the suit is brought during the contract period or not.
7. The Successful Proposer has sole responsibility for all insurance premiums and policy deductibles.
8. It is the Successful Proposer'S responsibility to ensure that his agents, representatives and subcontractors comply with the insurance requirements set forth herein. Successful Proposer shall include his agents, representatives, and subcontractors working on the project or at the worksite as insured under its policies, or Successful Proposer shall furnish separate certificates and endorsements for each agent, representative, and subcontractor working on the project or at the worksite. All coverages for agents, representatives, and subcontractors shall be subject to all of the requirements set forth to the procurement representative.
9. All required insurance policies must be written with a carrier having a minimum A.M. Best rating of A- FSC VII or better. In addition, the COUNTY has the right to review the Successful Proposer's deductible or self-insured retention and to require that it be reduced or eliminated.
10. Successful Proposer understands and agrees that the stipulated limits of coverage listed herein in this insurance section shall not be construed as a limitation of any potential liability to the COUNTY, or to others, and the COUNTY'S failure to request evidence of this insurance coverage shall not be construed as a waiver of Successful Proposer'S obligation to provide and maintain the insurance coverage specified.
11. Successful Proposer understands and agrees that the COUNTY does not waive its immunity and nothing herein shall be interpreted as a waiver of the COUNTY'S rights, including the limitation of waiver of immunity, as set forth in Florida Statutes 768.28, or any other statutes, and the COUNTY expressly reserves these rights to the full extent allowed by law.
12. No award shall be made until the Procurement Division has received the Certificate of Insurance in accordance with this section.

## BONDING REQUIREMENTS

**Bid Bond/Certified Check.** By submitting a proposal, the Successful Proposer agrees should its proposal be accepted, **to execute the form of Agreement and present the same to COUNTY for approval within ten (10) calendar days after notice of intent to award.** The Successful Proposer further agrees that failure to execute and deliver said form of Agreement **within ten (10) calendar days** will result in damages to COUNTY and as guarantee of payment of same a bid bond/certified check shall be enclosed within the submitted sealed proposal in the amount of five (5%) percent of the total amount of the proposal. The Successful Proposer further agrees that in case the Successful Proposer fails to enter into an Agreement, as prescribed by COUNTY, the bid bond/certified check accompanying the proposal shall be forfeited to COUNTY as agreed liquidated damages. If COUNTY enters into an agreement with a Successful Proposer, or if COUNTY rejects any and/or all proposals, accompanying bond will be promptly returned.

**Payment and Performance Bonds.** Prior to commencing work, the Successful Proposer shall obtain, for the benefit of and directed to COUNTY, a Payment and Performance Bond satisfying the requirements of Florida Statutes § 255.05, covering the faithful performance by the Successful Proposer of its obligation under the Contract Documents, including but not limited to the construction of the project on the project site and the payment and obligations arising thereunder, including all payments to Subcontractors, laborers, and materialmen. The surety selected by the Successful Proposer to provide the Payment and Performance Bond shall be approved by COUNTY prior to issuance of such Bond, which approval shall not be unreasonably withheld or delayed provided that surety is rated A- or better by Best's Key Guide, latest edition.

Failure to provide the required bonds on the prescribed form may result in Successful Proposer being deemed nonresponsive. Bonds must be in the form prescribed in Florida Statutes § 255.05, and must not contain notice, demand or other terms and conditions, including informal pre-claim meetings, not provided for in Florida Statutes § 255.05.

Bonds shall be in an amount equal to 100% of the contract price issued by a duly authorized and nationally recognized surety company, authorized to do business in the State of Florida, satisfactory to COUNTY. Surety shall be rated as "A-" or better by Best's Key Guide, latest edition. The attorney-in-fact who signs the bonds must file with the bonds, a certificate and effective dated copy of power-of-attorney. Payment and Performance Bonds shall be issued to "Manatee County, a political subdivision of the State of Florida", **within ten (10) calendar days after issuance of notice of intent to award.**

In addition, pursuant to Florida Statutes § 255.05(1)(b), Florida Statutes, prior to commencing work, the Successful Proposer shall be responsible and bear all costs associated to record the Payment and Performance Bond with the Manatee County Clerk of the Circuit Court. A certified copy of said recording shall be furnished to the Procurement Division upon filing. Pursuant to Florida Statutes § 255.05(1)(b), Florida Statutes, COUNTY will make no payment to the Successful Proposer until the Successful Proposer has complied with this paragraph.

Furnishing Payment and Performance Bonds shall be requisite to execution of an Agreement with COUNTY. Said Payment and Performance Bonds will remain in force for the duration of

this Agreement with the premiums paid by the Successful Proposer. Failure of the Successful Proposer to execute such Agreement and to supply the required bonds shall be just cause for cancellation of the award. COUNTY may then contract with the next lowest, responsive and responsible Successful Proposer or re-advertise this RFP.

Failure of COUNTY at any time to require performance by the Successful Proposer of any provisions set out in the resulting Agreement will in no way affect the right of COUNTY, thereafter, to enforce those provisions.

**FORM 8, INSURANCE STATEMENT**  
**RFP No. 26-R089352DJ**

**THE UNDERSIGNED** has read and understands the insurance requirements applicable to any Agreement resulting from this solicitation and shall provide the insurances required in this RFP within ten (10) days from the date of Notice of Intent to Award.

Proposer Name: \_\_\_\_\_ Date: \_\_\_\_\_

Signature  
(Authorized Official): \_\_\_\_\_

Printed Name/Title: \_\_\_\_\_

Insurance Agency: \_\_\_\_\_

Agent Name: \_\_\_\_\_ Agent Phone: \_\_\_\_\_

**Return this fully executed form with your Proposal.**

**FORM 9, INDEMNITY AND HOLD HARMLESS  
RFP No. 26-R089352DJ**

**MANATEE COUNTY, A POLITICAL SUBDIVISION OF THE STATE OF FLORIDA**

The Successful Proposer shall indemnify and hold harmless County, its officers, and employees from liabilities, damages, losses, and costs, including but not limited to reasonable attorney's fees, to the extent caused by the negligence, recklessness, or intentionally wrongful conduct of the Successful Proposer, its personnel, design professionals and other persons employed or utilized by the Successful Proposer in the performance of the Agreement, including without limitation, defects in design, or errors or omissions that result in material cost increases to County. Such indemnification shall include the payment of all valid claims, losses, and judgments of any nature whatsoever in connection therewith and the payment of all related fees and costs. County reserves the right to defend itself with its own counsel or retained counsel at Successful Proposer's expense.

Signature of Authorized Official of Proposer: \_\_\_\_\_

Title and Date: \_\_\_\_\_

Project Number and /or Name: \_\_\_\_\_

Insurance Agent: \_\_\_\_\_

Acknowledgement:

STATE OF \_\_\_\_\_

COUNTY OF \_\_\_\_\_

The foregoing instrument was acknowledged before me this \_\_\_\_ day of \_\_\_\_\_,  
20\_\_ by \_\_\_\_\_ [FULL LEGAL NAME],  
who is

Personally known to me

OR

has produced \_\_\_\_\_ as identification.

Notary Signature \_\_\_\_\_

Print Name \_\_\_\_\_

SEAL

**Return this fully executed form with your Proposal.**



**FORM 10, ANTI-HUMAN TRAFFICKING AFFIDAVIT**

**RFP No. 26-R089352DJ**

(Section 787.06, Florida Statutes)

Before me, the undersigned authority, personally appeared \_\_\_\_\_, who was sworn and says that the following information is true and correct:

1. My name is \_\_\_\_\_ of \_\_\_\_\_. I have been authorized by the Company to provide and execute this affidavit.
2. I am over eighteen years of age and the following information is given from my own personal knowledge.
3. Company is a nongovernmental entity and I hereby attest that Company does not use coercion for labor or services as defined in Section 787.06, Florida Statutes.
4. This affidavit is made and given by affiant under penalty of perjury with full knowledge of applicable Florida laws regarding sworn affidavits and the penalties and liabilities resulting from false statements and misrepresentations therein.

\_\_\_\_\_  
Signature

STATE OF \_\_\_\_\_  
COUNTY OF \_\_\_\_\_

Sworn to (or affirmed) and subscribed before me by means of

- physical presence or
- online notarization

this \_\_\_\_\_ day of \_\_\_\_\_, 2026, by \_\_\_\_\_, who

- is personally known to me or
- has produced \_\_\_\_\_ as identification.

[CHECK APPLICABLE BOXES TO SATISFY IDENTIFICATION REQUIREMENT OF SECTION 117.05, FLORIDA STATUTES]

\_\_\_\_\_  
Signature of Notary Public

My Commission Expires: \_\_\_\_\_

**Return this fully executed form with your Proposal.**

**EXHIBIT 1, SCOPE OF WORK/SERVICES**  
**RFP No. 26-R089352DJ**

**1.01 BACKGROUND INFORMATION**

Bishop Point is a Manatee County public park along the Manatee River located at 2020 72<sup>nd</sup> St. NW, Bradenton, FL. The peninsula-shaped park contains a degraded seawall along a narrow strip of land used for recreational activities such as fishing and watching sunsets. The proposed project will involve the transformation of the hardened shoreline into a living shoreline (LSL) using green and gray design techniques. Specifically, activities will include the removal of 426 lin. ft. of existing seawall, twenty-five (25) 5x5-inch concrete posts, twenty-five (21) concrete-filled, in-water PVC bollards, and approximately 24-lin. ft. of reinforced concrete pipe. On the eastern side of the peninsula, approximately 1,026 ft<sup>2</sup> of riprap will be installed at a 4:1 slope, while the western side will include 2952 ft<sup>2</sup> of riprap and deployment of 43-in-water, reef balls installed at 5-foot intervals. A 174- lin. ft., 5-foot-wide permeable paver walkway will be constructed in the uplands. Adjacent to the walkway, a 198- lin. ft., 4-foot-wide bioswale will be constructed within the uplands, passing under the walkway at one point eventually terminating at the Manatee River shoreline. Approximately 388 yd<sup>2</sup> of native vegetation will be planted along the shoreline in both uplands and along the tidal slopes. Finally, two staggered rows of in-water, reef balls, containing a total of 26 units, will be placed to the north of the living shoreline.

**1.02 SCOPE**

Successful Bidder (hereinafter in this Scope referred to as Contractor) shall furnish all equipment, labor, materials, supplies, licensing, transportation, and other components necessary to meet the requirements of the Agreement.

**1.03 GENERAL REQUIREMENTS**

Contractor shall provide the following requirements:

- A. The work Consists of providing all construction, labor, equipment, material, and operations in connection with the shoreline improvements as shown on the provided drawings
- B. Any discrepancies in the plans with the field conditions shall be brought to the immediate attention of the engineer. Construction shall not continue until the engineer has addressed the discrepancies.
- C. The Contractor shall take all necessary precautions to protect existing structures in the project vicinity. Any damage to private or public property within the project vicinity, including staging sites, work, and access areas shall be repaired promptly by the Contractor. Any damage resulting from the Contractor's operations shall be repaired at no cost to the owner. All access and staging areas shall be kept neat, orderly, and in a safe manner. All access and staging areas shall be restored to the pre-construction conditions upon project completion at the cost of the Contractor. The site shall be restored by removing and finishing all evidence for construction. In the event infrastructure (such as walkways, sidewalks, fences, vegetation, etc.) is temporarily removed or relocated, or there is unauthorized damage to vegetation and/or facilities by the Contractor, the Contractor shall restore all damage to structures and natural features to pre-construction conditions or better.
- D. Utilities are not shown in the plans. Contractor is responsible for locating all existing utilities prior to construction.

- E. The Contractor is responsible for providing proper clearance and protection to all overhead wires and obstructions.
- F. The Contractor shall exclude the public from the work areas in the immediate vicinity of operations. The Contractor shall provide appropriate safety measures to protect the public.
- G. All new structural work including concrete and reinforcement shall be accurately field measured and dimensions verified by the Contractor prior to ordering materials. The Contractor shall be prepared to make field adjustments to accurately fit the new work to existing conditions.
- H. No construction shall commence until all required permits and approvals have been secured and the contractor has been issued notice to proceed.
- I. Construction shall be executed in accordance with all local, state, and federal regulations including Manatee County, FDEP, and USACE. The Contractor shall adhere to all conditions of the permits.
- J. Work will be conducted during daylight hours.
- K. The Contractor shall provide photographs or video of the work area prior to commencing work to document the pre-construction conditions of existing infrastructure.

#### **1.04 SERVICE REQUIREMENTS**

Contractor's services shall include but not be limited to:

- A. Removal of Shoreline Structures
  - a. The Contractor shall remove the following structures in their entirety:
    - i. Approximately 426 lin. ft. of existing seawall and concrete debris
    - ii. Approximately 25 wooden posts (5 in. x 5 in.)
    - iii. Approximately 21 concrete-filled PVC bollards
    - iv. Approximately 24 lin. ft. of 24" reinforced concrete pipe (RCP)
  - b. All removed materials shall be legally disposed of offsite at an approved facility.
- B. Shoreline Stabilization and Living Shoreline Construction
  - a. The Contractor shall install riprap as follows:
    - i. Up to approximately 3,789ft<sup>2</sup> (700 yd<sup>3</sup>) of material at a 4:1 slope
  - b. The Contractor shall install approximately 69 reef balls as described below:
    - i. Reef balls shall be standard, marine-grade manufactured units measuring approximately 2.9ft x 4ft or County approved equivalent.
    - ii. Reef balls shall be manufactured by Reef Innovations and shall be their standard "Pallet Ball" model, which matches the required dimensional and structural specifications.
      - 1. Any alternative manufacturer or product must be submitted for review and receive written County approval prior to procurement.
    - iii. Approximately 43 reef balls shall be placed along the western shoreline (along the footprint of the removed pilings) at 5-ft intervals.
    - iv. Approximately 26 reef balls shall be placed in two staggered rows, in two locations on the north and northwest sections of the site.
  - c. The Contractor shall grade the shoreline between the riprap and reef balls to a 3:1 slope to accommodate living shoreline plantings.
    - i. The planting zone shall be approximately 3,492f

- d. The Contractor shall install native vegetation appropriate for the intertidal estuarine zone, including but not limited to species specified in the County design plans. Any deviation from the provided planting plans needs to be pre-approved by the County Project Manager.
  - i. Planting density per species shall follow design documents
  - ii. All plants shall be nursery-grown, containerized stock, free of invasive species
  - iii. Contractor shall water, protect, and maintain plantings for the duration of construction
- C. Upland Improvements
  - a. The Contractor shall construct a 174 lin. ft., 5-foot-wide permeable paver walkway as follows:
    - i. Extending from the uplands to the mean high-water line (MHWL)
    - ii. Situated between the riprap and reef ball treatment areas
    - iii. Constructed using permeable paver blocks on a stabilized permeable base
    - iv. Final elevations shall match plans to maintain sheet-flow drainage toward the bioswale
  - b. The Contractor shall construct a 198 linear foot, 4-foot wide bioswale as follows:
    - i. Beginning in the uplands, crossing beneath the permeable walkway, and continuing to the MHWL
- D. All service personnel shall be uniformed (with the Contractor's name on the uniform) and qualified to perform the Services as listed herein.
- E. All service personnel shall maintain protection of all supplies from damage and protect all property (public and private) from loss arising in connection with the work.
- F. All service personnel minimize traffic disruptions and public inconvenience near the work area while ensuring the safety of people and property.
- G. No street shall be closed to the public without prior approval from the County.
- H. Fire hydrants must be kept accessible.
- I. All services and deliveries must be performed during daylight hours.
- J. Weekend work requires prior written approval from the County's Project Manager.
- K. All work shall be conducted in accordance with federal and state permit requirements.
- L. The contractor shall submit regularly scheduled progress reports, and invoicing to the County's Project Manager.
- M. The contractor shall maintain all required licenses and certifications for the duration of the project.
- N. The contractor shall be responsible for timely delivery of services.
- O. The contractor shall ensure high quality of work.
- P. A pre-project meeting is required prior to any work being conducted.
- Q. The contractor shall provide final as-built drawings for project records

**1.05 EXPECTED OUTCOMES OR DELIVERABLES**

Contractor shall:

- A. Upon completion, the project will enhance the waterfront amenities at Bishop Point by removal and/or retrofit of an existing deteriorating seawall/bulkhead and installation of a living shoreline along approximately 0.21 acres.
- B. The contractor shall provide final as-builts for project records and permit close-outs.

**1.06 ACCESSIBILITY**

Contractor shall ensure all electronic information, documents, applications, reports, and deliverables required under the Agreement are in a format that meets the requirements of Section 508 of the Rehabilitation Act and best practices (W3C WCAG 2).

Where not fully compliant with these requirements and best practices, Contractor shall provide clear points of contact for each document and information technology to direct users in how to obtain alternate formats. Further, Contractor shall develop accommodation strategies for those non-compliant resources and implement strategies to resolve the discrepancies.

**1.07 COUNTY RESPONSIBILITIES**

- A. County will provide copies of all permits and engineering reports.
- B. County must review and approve any changes to work plans.

**1.08 ESTIMATED PROJECT COMPLETION DATE**

The estimated project completion time frame for the pre-construction and construction phase is 183 calendar days from the Notice to Proceed.

**1.09 ESTIMATED PROJECT COST**

The County will determine price reasonableness in accordance with 2 CFR 200.324 using an Independent Cost Estimate. The County has budgeted the project construction cost at approximately \$604,316.00.

**END EXHIBIT 1**

**EXHIBIT 2, PROPOSAL RESPONSE REQUIREMENTS  
RFP No. 26-R089352DJ**

This section identifies specific information which must be contained within the Proposal and the order in which such information should be organized. The information each Proposer provides will be used to determine those Proposers with the background, experience, and capacity to perform the scope of services as stated in this RFP and which Proposer(s) best meets the overall needs of the County. For more information on the evaluation process, refer to Section B, Evaluation of Proposals.

**2.01 INFORMATION TO BE SUBMITTED**

The contents of each Proposal will be organized and arranged with tabs in the same order as listed below and with the same TAB numbers. The Proposal should contain sufficient detail to permit the County to conduct a meaningful evaluation. However, overly elaborate proposals are not requested or desired. **NOTE: TABS 5, 6, 7, 8, & 9 ARE LIMITED TO A TOTAL OF 35 ONESIDED PAGES**

**2.02 PROPOSAL FORMAT**

**A. FORMAT**

For more information regarding submission of Proposals, refer to the Request for Proposals, Section A.04, Submission of Proposals.

**B. TAB 1 - INTRODUCTION**

In Tab 1, include the following:

1. A cover page that identifies Proposer, the RFP by title and the RFP number.
2. An introductory letter/statement that describe your Response in summary form (limit 2 pages).
3. A table of contents.

**C. TAB 2 – MINIMUM QUALIFICATION REQUIREMENTS**

In Tab 2, submit the information and documentation requested that confirms Proposers meets the following minimum qualification requirement(s):

1. Proposer must be registered with the State of Florida, Division of Corporations to do business in Florida.

**No documentation is required. The County will verify registration.**

2. Proposer and must possess current, valid licenses and certifications required under Florida Statute to perform General Contractor services.

**Submit information and documentation from the issuing agency that confirms Proposer and/or its subcontractor(s) meet the following:**

- a. **Certified under Section 489.119, Florida Statutes, to engage in contracting**

**through a certified or registered general contractor as the qualifying agent.**

3. Proposer is not listed on the Florida State Board of Administration, Scrutinized List of Prohibited Companies found on the SBAFLA website.

**No documentation is required. The County will verify.**

4. Proposer is not on the Florida Department of Management Services Suspended, Debarred, and Convicted Vendor Lists.

**No documentation is required. The County will verify.**

5. Proposer is not on the Federal Convicted Vendor or Excluded Parties list (SAM/EPLS).

**No documentation is required. The County will verify.**

6. Proposer is not on the Florida Department of Transportation Contractor Suspended List.

**No documentation is required. The County will verify.**

7. Proposer has not been convicted of a public entity crime per Section 287.133, Florida Statutes, or environmental law in the past five (5) years.

**Proposer must complete Form 3 and submit with its Proposal attesting that it has not been convicted of a public entity crime or environmental law in the past five (5) years.**

8. If Proposer is submitting as a joint venture, Proposer must have file the required documents with the Florida Department of Business and Professional Regulation as required by Florida Statute Section 489.119, prior to the Due Date and Time for submission of Proposals in response to this RFP.

**If Proposer is a joint venture, Proposer must provide a copy of Proposer's approved filing with the Florida Department of Business and Professional Regulation.**

9. Proposer has no reported conflict of interests in relation to this RFP.

**If no conflicts of interests are present, Proposer must submit a fully completed copy of Form 4.**

**If there is a potential conflict of interest, on a separate page submit a statement to that affect and disclose the name of any officer, director or agent who is an employee of the County. Disclose the name of any County employee who owns, directly or indirectly, any interest in Proposer's firm or any of its branches.**

**D. TAB 3 – FORMS**

In Tab 3, provide the completed and executed Forms listed below.

- Form 1, Acknowledgement of Addenda
- Form 2, Proposal Signature Form
- Form 3, Public Contracting and Environmental Crimes Certification
- Form 4, Conflict of Interest Disclosure Form
- Form 5, Non-Collusion Affidavit
- Form 6, Truth in Negotiation Certification
- Form 7, Scrutinized Company Certification
- Form 8, Insurance Statement
- Form 9, Indemnity and Hold Harmless
- Form 10, Anti-Human Trafficking Affidavit

**E. TAB 4 – TRADE SECRETS**

In Tab 4, Pursuant to Section A.28, Trade Secrets, identify any trade secret being claimed.

**NOTE: Designation of the entire Proposal as “Trade ‘Secret’, ‘Proprietary’ or ‘Confidential’ is not permitted and may result in a determination that the Proposal is non-responsive and therefore will not be evaluated or considered.**

Proposer must submit purported trade secret as follows:

1. Trade secret material must be segregated, within the applicable TAB, from the portions of the Response that are not being declared as trade secret. **NOTE:** Responses cannot be designated as ‘Proprietary’ or ‘Confidential’ in their entirety.
2. Proposer shall cite, for each trade secret being claimed, the Florida Statute number which supports the designation.
3. Proposer shall provide a brief written explanation as to why information claimed as trade secret fits the cited Statute.
4. Proposer shall provide an additional electronic copy of its Response that redacts all designated trade secrets.

**F. TAB 5 – PROPOSER STATEMENT OF ORGANIZATION**

In Tab 5, provide information and documentation on Proposer as follows:

1. Legal contracting name including any dba.
2. State of organization or incorporation.
3. Ownership structure of Proposer’s company.  
(e.g., Sole Proprietorship, Partnership, Limited Liability Corporation, Corporation)
4. Federal Identification Number.
5. A fully completed (signed and dated) copy of Proposer’s W-9.
6. Contact information for Proposer’s corporate headquarters and local office (if different)  
NOTE: local is defined as Manatee, DeSoto, Hardee, Hillsborough, Pinellas, or Sarasota counties.
  - a. Address
  - b. County, State, Zip



- c. Phone
- d. Number of years at this location
- 7. List of officers, owners and/or partners, or managers of the firm. Include names, addresses, email addresses, and phone numbers.
- 8. Provide supporting documentation from the certifying agent indicating Proposer is a certified Minority-owned Business Enterprise, if applicable.
- 9. Contact information for Proposer's primary and secondary representatives during this RFP process to include the following information:
  - a. Name
  - b. Phone
  - c. E-mail
  - d. Mailing Address
  - e. County, State, Zip
- 10. Provide a brief summary regarding any prior or pending litigation, either civil or criminal, involving a governmental agency or which may affect the performance of the services to be rendered herein, in which the Proposer, any of its partners, employees or subcontractors is or has been involved within the last three (3) years.
- 11. Provide details of any ownership changes to Proposer's organization in the past three (3) years or changes anticipated within six (6) months of the Due Date and Time (e.g., mergers, acquisitions, changes in executive leadership).
- 12. Detail Proposer's accessibility under Section 508 of the Rehabilitation Act strategies and processes as follows:
  - a. Detail Proposer's strategies and approach to meeting the ADA accessibility compliance standards of Section 508 and/or WCAG 2.0 AA for all documents to be submitted under the Agreement.
  - b. Briefly describe Proposer's ADA accessibility conformance testing process.

**G. TAB 6 – PROPOSER AND TEAM'S EXPERIENCE (MAXIMUM POINTS 20)**

In Tab 6, provide details of Proposer and its team's experience to include the following:

- 1. Provide a summary of Proposer's background, size, and years in business.
- 2. Describe Proposer's experience in living shoreline, marine construction, and/or coastal restoration services for other government agencies, particularly those within Florida.
- 3. Provide Proposer's years of experience in living shoreline, marine construction, and/or coastal restoration services.
- 4. Identify and include information regarding experience and qualifications of Proposer's key staff to be assigned to the services. Include a resume for each with the name of the firm(s) for their current and previous employers, their full names, professional credentials (e.g., certifications and/or licenses), and roles and duties which the individuals will provide to the County, only relevant to the project. Include the address of their current primary office location, email address and phone number.
- 5. Identify any proposed sub-consultants to accomplish the work. Include the company name, the name of the individual(s) to be assigned, and an overview of their experience and qualifications applicable to their role in the provision of the services for the County.
- 6. Describe any significant or unique accomplishments, recognition, or awards received by Proposer, its key personnel, or its subcontractors for previous similar services.
- 7. Provide a minimum of 2 client references for living shoreline, marine construction,

and/or coastal restoration services performed by Proposer since February 1, 2021, who are agreeable to responding to an inquiry by the County. References should include the following information:

- a. Client name
  - b. Client address
  - c. Client contact name
  - d. Client contact phone and fax numbers
  - e. Client contact email address
  - f. Brief description of work (1-2 sentences)
  - g. Performance period (start/end dates)
  - h. Total dollar value of contract
8. Provide any additional information that would assist the County in the evaluation of Proposer and team's experience.

#### **H. TAB 7 – APPROACH (MAXIMUM POINTS 25)**

In Tab 7, provide Proposer's project approach to include the following:

1. A narrative of the project approach and an explanation of how this approach meets County objectives and requirements as specified in this RFP.
2. An explanation of Proposer's technical ability to perform all facets of the scope of services defined in Exhibit 1. If more than one Proposer is jointly filing a Response, details must be provided to clearly demonstrate individual roles and responsibility for all components of the project.
3. Details of implementation plan and schedule. Provide an implementation schedule for each component of services (e.g., design, demolition, construction). NOTE: Proposer must commit to a timetable of no more than 183 calendar days for substantial completion of the project.
4. Provide a narrative of the methodology for engaging with County representatives in-the-course of performing the duties.
5. Proposer shall thoroughly explain:
  - a. Its accessibility in the areas of availability for meetings, general communications, coordination, and supervision.
  - b. How Proposer physically plans on attending pre-scheduled meetings.
  - c. How Proposer plans on ensuring accessibility and availability during the term of the Agreement.
6. Proposer's Risk Management and Safety Plan that includes a list of risks related to the provision of services and Proposer's proposed mitigation procedures for each item.
7. Include a detailed description of the Proposer's safety plan to control the environment of the work site during on site construction.

Provide sample reports Proposer has previously used on projects to include the following: Daily/weekly progress reports, safety reports, QA/QC reports, environmental compliance, schedule/tracking updates, and final close out, (limit 20 pages). This does not count against the page total
8. Proposers are encouraged to propose the use of as many environmentally preferable, sustainable, 'green' products, materials and supplies to promote a safe and healthy environment. Submit a summary of Proposer's environmental sustainability initiatives and any products, materials or supplies that are proposed for the County's work that

- have documented evidence of reducing adverse effects on the environment.
9. Provide a statement on company letterhead and signed by an authorized official of Proposer attesting to its commitment to meet the County's time and budget requirements for all assigned work.
  10. Provide any additional information that would assist County in the evaluation of Proposer's approach to provide the required services.

**I. TAB 8 - CAPACITY (MAXIMUM POINTS 20)**

In Tab 8, provide Proposer's capacity to include the following:

1. Submit details of Proposer's staffing resources, at the location that will provide services to the County as well as corporately, by discipline and the number of personnel within each discipline.
2. Detail the location of the managing office and what plans will be adopted to ensure County citizens receive consideration for employment; and vendors located within the County will be used for the acquisition of goods and services needed to perform the scope of services.
3. If Proposer's staffing resources includes sub-consultants, submit the name of the firm(s) who will perform each discipline. If more than one firm is listed for a discipline, then label which firm is the primary firm for that discipline. Firms may perform more than one (1) discipline.
4. Submit an organizational diagram clearly identifying key personnel as well as other staffing resources who are designated to provide services to the County. For each individual in the organization diagram, include each individual's name, title, firm and indicate their functional relationship to each other.
5. If Proposer is teaming with other entities to provide the required goods and services, detail any prior similar work any two or more team members have jointly performed.
6. If a joint venture is proposed, provide an affidavit attesting to the formulation of the joint venture and provide proof of incorporation as a joint venture or a copy of the formal joint venture agreement between all joint venture parties, indicating their respective roles, responsibilities, and levels of participation in the project.
7. An explanation, in general terms, of Proposers' financial capacity to perform the scope of services. If Proposer is jointly filing a Response with other entities, details must be provided to demonstrate financial capacity of each entity.
8. Provide a statement on company letterhead and signed by a company official authorizing a County auditor and/or financial analysts access to your financial records, including all records prepared by an independent firm, or the financial records of other entities for which you have ownership interest. Such access will occur at the primary location of the Proposer, or such other location as may be agreed, for the purposes of verifying financial representations, and/or to review and assess the historical and current financial capacity of Proposer's business entity and its expected ability to meet ongoing financial obligations related to the required services, if awarded a contract. If an audit is conducted, the County's audit and/or financial analysts will report their findings in a summary report to the Procurement Official, which will be placed in the Response files for subsequent use, review, and discussions during evaluations.
9. Disclose any ownership interest in other entities proposed for services. This ownership

disclosure includes ownership by the Proposer through a parent, subsidiary or holding company or any other form of business entity. Submit entity names and the percent of ownership for each.

10. Provide details of Proposer and any subcontractor's current workloads and any projected changes to the workload within the next six (6) months.
11. Provide a list of projects that have been awarded to the Proposer by Manatee County in the past two years since February 1, 2024. Include the following information for each:
  - a. Name of the project.
  - b. Date of award.
  - c. Dollar value of the design work.
12. Provide details of Proposer's capacity to bond the project. Include a letter of intent form Proposer's bonding company which confirms Proposer's bonding capacity.
13. Provide any additional information that would assist the County in the evaluation of Proposer's capacity to provide the required services.

**J. TAB 9 - SIMILAR COMPLETED PROJECTS (MAXIMUM POINTS 25)**

Provide a list of up to 3 projects, particularly those of living shoreline, marine construction, and/or coastal restoration services, which Proposer has provided since February 1, 2021. Include the following information:

- a. Organization/Owner name
- b. Address (County/State)
- c. Project date (Start/End)
- d. Proposer's role in the project (e.g., prime/lead, sub)
- e. Scope of work (Brief description 1-2 sentences)
- f. Total project costs

NOTE: Representative photographs and exhibits supporting the above projects are permitted as an attachment to this section (limit 5 pages). This does not count against the page total

**K. TAB 10 – FEE PROPOSAL (MAXIMUM POINTS 10)**

In Tab 10, Proposer shall provide a rate and fee structure for Bishop Point Living Shoreline.

**END OF EXHIBIT 2**

**EXHIBIT 3 - BID PRICING FORM  
26-R089352DJ BISHOP POINT LIVING SHORELINE**

**Bidders must provide prices for each available line item on each tab for their bid to be considered responsive.**

**\*To be considered responsive, it is the sole responsibility of the bidder to correctly calculate and manually enter all sub-total, contingency, and total bid price fields.**

<b>BID ITEM</b>	<b>DESCRIPTION</b>	<b>ESTIMATED QUANTITY</b>	<b>UNIT</b>	<b>UNIT PRICE 183 Calendar Days</b>	<b>AMOUNT</b>
1	Mobilization	1	LS		
2	Maintenance of Traffic	1	LS		
3	Survey	1	LS		
4	Erosion and Sediemnt Controls	1	LS		
5	Demolition/Debris Hauling and Disposal	1	LS		
6	Shoreline Grading and Earthwork	100	CY		
7	Rip Rap	701	CY		
8	Inlet Structure Replacement	1	LS		
9	Permeable Paver Walkway	870	SF		
10	Reefball (Pallet Ball)	69	EA		
11	Shoreline Plantings - Total	388	SY		
12	Bioswale Construction	792	SF		
<b>SUBTOTAL</b>					
13	Contingency (Used only with County Approval)	10%	LS		
<b>GRAND TOTAL</b>					

Successful Contractor fees for proposed services shall remain firm for a minimum of 12 months after execution of the Agreement.

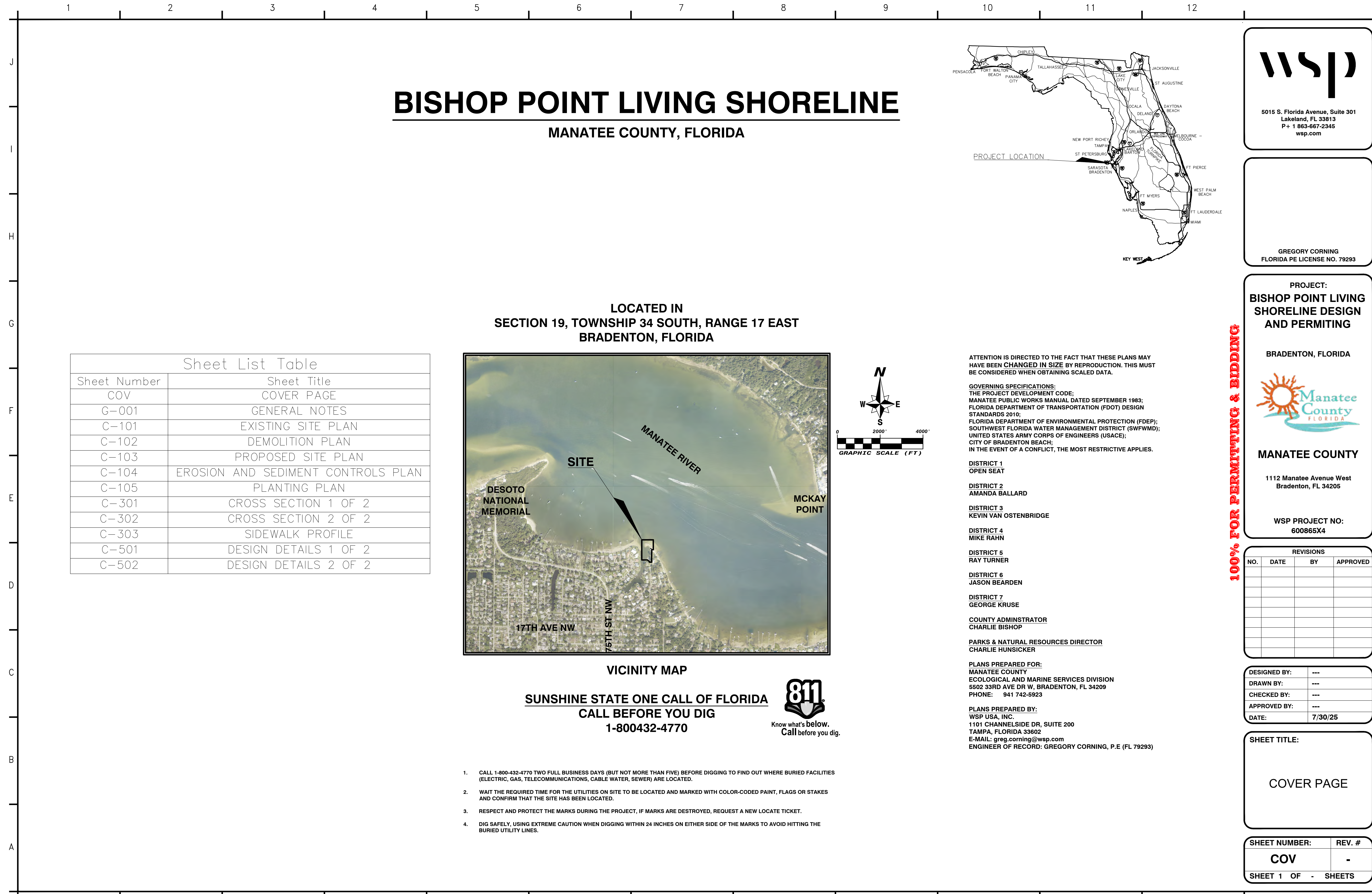

# BISHOP POINT LIVING SHORELINE

## MANATEE COUNTY, FLORIDA

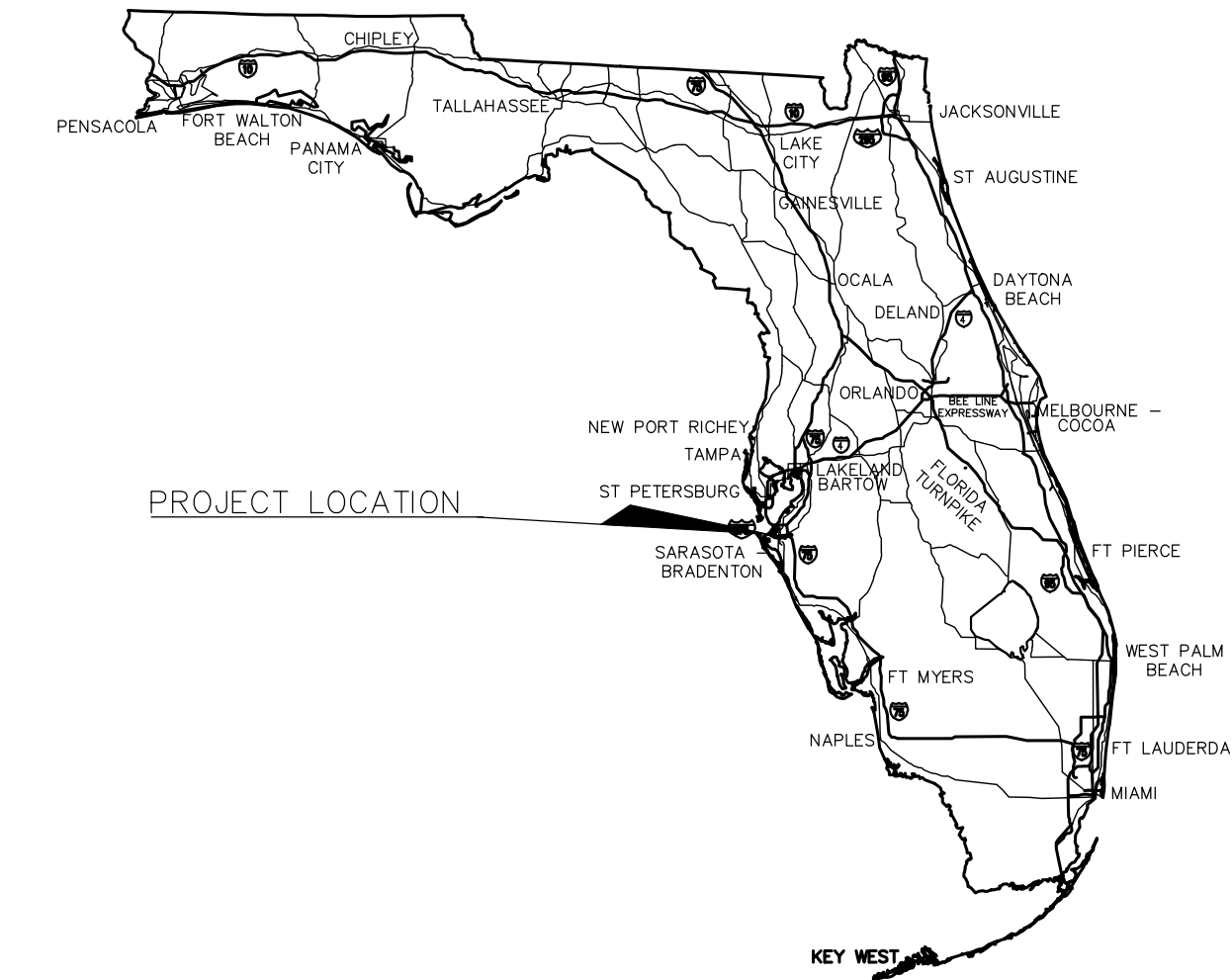

**wsp**

5015 S. Florida Avenue, Suite 301  
Lakeland, FL 33813  
P+ 1 863-667-2345  
wsp.com

GREGORY CORNING  
FLORIDA PE LICENSE NO. 79293

**PROJECT:**  
**BISHOP POINT LIVING SHORELINE DESIGN AND PERMITTING**

BRADENTON, FLORIDA

**MANATEE COUNTY**

1112 Manatee Avenue West  
Bradenton, FL 34205

**WSP PROJECT NO:**  
**600865X4**

**100% FOR PERMITTING & BIDDING**

**LOCATED IN  
SECTION 19, TOWNSHIP 34 SOUTH, RANGE 17 EAST  
BRADENTON, FLORIDA**

Sheet List Table	
Sheet Number	Sheet Title
COV	COVER PAGE
G-001	GENERAL NOTES
C-101	EXISTING SITE PLAN
C-102	DEMOLITION PLAN
C-103	PROPOSED SITE PLAN
C-104	EROSION AND SEDIMENT CONTROLS PLAN
C-105	PLANTING PLAN
C-301	CROSS SECTION 1 OF 2
C-302	CROSS SECTION 2 OF 2
C-303	SIDEWALK PROFILE
C-501	DESIGN DETAILS 1 OF 2
C-502	DESIGN DETAILS 2 OF 2



**VICINITY MAP**

**SUNSHINE STATE ONE CALL OF FLORIDA**  
**CALL BEFORE YOU DIG**  
**1-800432-4770**



Know what's below.  
Call before you dig.

1. CALL 1-800-432-4770 TWO FULL BUSINESS DAYS (BUT NOT MORE THAN FIVE) BEFORE DIGGING TO FIND OUT WHERE BURIED FACILITIES (ELECTRIC, GAS, TELECOMMUNICATIONS, CABLE WATER, SEWER) ARE LOCATED.
2. WAIT THE REQUIRED TIME FOR THE UTILITIES ON SITE TO BE LOCATED AND MARKED WITH COLOR-CODED PAINT, FLAGS OR STAKES AND CONFIRM THAT THE SITE HAS BEEN LOCATED.
3. RESPECT AND PROTECT THE MARKS DURING THE PROJECT, IF MARKS ARE DESTROYED, REQUEST A NEW LOCATE TICKET.
4. DIG SAFELY, USING EXTREME CAUTION WHEN DIGGING WITHIN 24 INCHES ON EITHER SIDE OF THE MARKS TO AVOID HITTING THE BURIED UTILITY LINES.

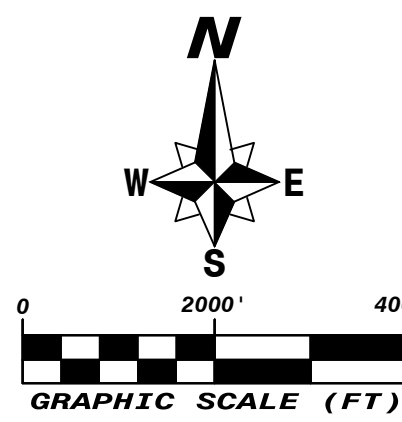

ATTENTION IS DIRECTED TO THE FACT THAT THESE PLANS MAY HAVE BEEN CHANGED IN SIZE BY REPRODUCTION. THIS MUST BE CONSIDERED WHEN OBTAINING SCALED DATA.

**GOVERNING SPECIFICATIONS:**  
THE PROJECT DEVELOPMENT CODE;  
MANATEE PUBLIC WORKS MANUAL DATED SEPTEMBER 1983;  
FLORIDA DEPARTMENT OF TRANSPORTATION (FDOT) DESIGN STANDARDS 2010;  
FLORIDA DEPARTMENT OF ENVIRONMENTAL PROTECTION (FDEP);  
SOUTHWEST FLORIDA WATER MANAGEMENT DISTRICT (SWFWMD);  
UNITED STATES ARMY CORPS OF ENGINEERS (USACE);  
CITY OF BRADENTON BEACH;  
IN THE EVENT OF A CONFLICT, THE MOST RESTRICTIVE APPLIES.

**DISTRICT 1**  
OPEN SEAT

**DISTRICT 2**  
AMANDA BALLARD

**DISTRICT 3**  
KEVIN VAN OSTENBRIDGE

**DISTRICT 4**  
MIKE RAHN

**DISTRICT 5**  
RAY TURNER

**DISTRICT 6**  
JASON BEARDEN

**DISTRICT 7**  
GEORGE KRUSE

**COUNTY ADMINISTRATOR**  
CHARLIE BISHOP

**PARKS & NATURAL RESOURCES DIRECTOR**  
CHARLIE HUNSICKER

**PLANS PREPARED FOR:**  
MANATEE COUNTY  
ECOLOGICAL AND MARINE SERVICES DIVISION  
5502 33RD AVE DR W, BRADENTON, FL 34209  
PHONE: 941 742-5923

**PLANS PREPARED BY:**  
WSP USA, INC.  
1101 CHANNELSIDE DR, SUITE 200  
TAMPA, FLORIDA 33602  
E-MAIL: greg.corning@wsp.com  
ENGINEER OF RECORD: GREGORY CORNING, P.E (FL 79293)

REVISIONS			
NO.	DATE	BY	APPROVED

DESIGNED BY:	---
DRAWN BY:	---
CHECKED BY:	---
APPROVED BY:	---
DATE:	7/30/25

**SHEET TITLE:**

COVER PAGE

<b>SHEET NUMBER:</b>	<b>REV. #</b>
COV	-
SHEET 1 OF - SHEETS	

NOTES:

**A. GENERAL**

1. PROPERTY OWNER'S NAME AND ADDRESS:  
**MANATEE COUNTY**  
 1112 MANATEE AVENUE WEST  
 BRADENTON, FL 34205  
 PARCEL ID# 2995600009

PROJECT LOCATION: LAT: 27°31'10.02"N LONG: 82°38'0.13"W

**DESCRIPTION:**

2. THE TYPES OF SOIL DISTURBANCE ACTIVITIES INCLUDE: GRADING AND EXCAVATING

3. CONSTRUCTION AND DEMOLITION DEBRIS SHOULD BE REMOVED FROM THE SITE AND DISPOSED ACCORDING TO FLORIDA DEPARTMENT OF ENVIRONMENTAL PROTECTION CHAPTER 62-701.

4. SEQUENCE OF MAJOR ACTIVITIES:

a. INSTALL TEMPORARY EROSION AND SEDIMENTATION CONTROLS AND MAINTAIN THROUGHOUT PROJECT.

b. CONSTRUCT STAGING AREAS.

c. CONSTRUCT FEATURES ACCORDING TO ENGINEERING DESIGN PLANS AND TECHNICAL SPECIFICATIONS.

d. OBTAIN FINAL APPROVAL, REMOVE EROSION AND SEDIMENTATION CONTROLS AND STABILIZE ANY AREA DISTURBED BY THEIR REMOVAL.

5. AREA ESTIMATES: TOTAL PARCEL BOUNDARY = 0.21 ACRES.

6. IT IS THE RESPONSIBILITY OF THE CONTRACTOR TO DEVELOP AND IMPLEMENT A STORMWATER POLLUTION PREVENTION PLAN (SWPPP) IN ACCORDANCE WITH THE EPA NPDES GENERAL PERMIT FOR STORMWATER DISCHARGES FROM CONSTRUCTION ACTIVITIES, THE FDEP GENERIC PERMIT FOR STORMWATER DISCHARGES FROM CONSTRUCTION ACTIVITIES AND ALL OTHER FEDERAL, STATE AND LOCAL REQUIREMENTS.

7. MANATEE COUNTY AND THE CONTRACTOR SHALL HAVE A PRE-CONSTRUCTION MEETING TO DISCUSS THE COMPLEXITY AND POTENTIAL PUBLIC CONCERNS WITH THE PROJECT.

8. BEARINGS, DISTANCES, COORDINATES & ELEVATIONS SHOWN HEREON ARE RELATIVE TO THE NORTH AMERICAN VERTICAL DATUM OF 1988 (NAVD 88), RESPECTIVELY, BASED ON NATIONAL SPATIAL REFERENCE SYSTEM CONTROL STATIONS:

9. ANY MATERIAL TO BE STOCKPILED FOR PERIODS GREATER THAN 24 HOURS SHALL BE PROTECTED BY THE APPROPRIATE EROSION CONTROL MEASURES.

10. THE CONTRACTOR IS ALERTED TO THE PRESENCE OF OVERHEAD WIRES AND POLES IN THE AREA. THE METHOD OF CONSTRUCTION FOR THESE LOCATIONS MUST COMPLY WITH OSHA SAFETY STANDARDS. THE CONTRACTOR SHALL INSPECT THESE SITES AND WILL BE RESPONSIBLE FOR DETERMINING WHAT METHOD OF PREPARATION AND INSTALLATION WILL BE USED TO COMPLY WITH THESE REQUIREMENTS. THE METHOD OF PREPARATION AND INSTALLATION MUST HAVE THE ENGINEER'S AND UTILITY OWNER'S APPROVAL.

11. ANY DISCREPANCIES BETWEEN THE PLANS AND ACTUAL FIELD CONDITIONS SHALL BE BROUGHT TO THE ATTENTION OF THE ENGINEER OF RECORD.

12. NO FIELD CHANGES OR DEVIATIONS FROM THE DESIGN ARE TO BE MADE WITHOUT PRIOR APPROVAL OF THE ENGINEER OF RECORD.

**B. TEMPORARY EROSION AND SEDIMENT CONTROL**

1. CONTRACTOR SHALL INSTALL PRIOR TO AND MAINTAIN DURING CONSTRUCTION ALL SEDIMENT CONTROL MEASURES AS REQUIRED TO RETAIN ALL SEDIMENTS ON THE SITE. IMPROPER SEDIMENT CONTROL MEASURES MAY RESULT IN CODE ENFORCEMENT VIOLATIONS.

2. ALL SILT FENCE AND FLOATING TURBIDITY BARRIERS MUST BE PLACED AS ACCESS IS OBTAINED DURING CLEARING. NO GRADING SHALL BE DONE UNTIL SILT FENCE AND TURBIDITY BARRIERS ARE INSTALLED.

3. SILT FENCE AND FLOATING TURBIDITY BARRIERS ARE TO BE PLACED AS SHOWN AND/OR DIRECTED BY ENGINEER.

4. EROSION CONTROL MEASURES WILL BE INSPECTED AT LEAST DAILY, AFTER EACH RAIN AND REPAIRED BY THE GENERAL CONTRACTOR. CLEAN OUT OF SEDIMENT CONTROL STRUCTURES WILL BE PERFORMED BY THE CONTRACTOR WHEN SEDIMENT HAS ACCUMULATED TO ONE-THIRD (1/3) OF THE HEIGHT OF THE INDIVIDUAL STRUCTURE FOR TEMPORARY SEDIMENT BASINS & RETROFITTED DETENTION PONDS, ONE-HALF (1/2) FULL FOR SILT FENCE, TURBIDITY BARRIERS, CHECK DAMS, ROCK FILTER DAMS, AND INLET SEDIMENT TRAPS.

5. THE CONTRACTOR IS RESPONSIBLE FOR LOCATING SEDIMENT AND EROSION CONTROL MEASURES TO PROVIDE OPTIMUM SEDIMENT AND EROSION CONTROL. SEDIMENT AND EROSION CONTROL MEASURES SHALL COMPLY WITH STATE OF FLORIDA EROSION AND SEDIMENT CONTROL MANUAL, DATED JULY 2013.

6. ADDITIONAL EROSION AND SEDIMENT CONTROL MEASURES SHALL BE INSTALLED IF DEEMED NECESSARY BY ON-SITE INSPECTION OF MANATEE COUNTY DESIGNATED REPRESENTATIVE.

7. THE CONTRACTOR SHALL PROTECT ANY EXISTING DITCHES, WETLAND VEGETATION, STORM DRAIN PIPES, AND INLETS IN THE VICINITY OF WORK TO BE PERFORMED FROM DAMAGE OR SILTATION, WHETHER OR NOT SPECIFICALLY IDENTIFIED IN THE PLANS.

8. EROSION CONTROL MEASURES DESCRIBED SHALL BE MAINTAINED UNTIL GRASS ON PLANTED SLOPES IS SUFFICIENTLY ESTABLISHED TO BE AN EFFECTIVE EROSION DETERRENT.

9. ALL GRASSING SHALL BE IN ACCORDANCE WITH THE ATTACHED SPECIFICATIONS.

10. CONSTRUCTION EXITS SHALL BE MAINTAINED IN A CONDITION WHICH WILL PREVENT TRACKING OR FLOW OF MUD INTO PUBLIC STREETS. IF TRACKING OR FLOW OF MUD OCCURS, CONTRACTOR SHALL CONSTRUCT A SOIL TRACKING PREVENTION DEVICE IN ACCORDANCE WITH FDOT DESIGN STANDARDS FY 2024-25, SECTION 104.

11. TEMPORARY PROTECTION DEVICES MUST BE MAINTAINED UNTIL PROJECT COMPLETION OR VEGETATION MEASURES ARE ESTABLISHED.

12. REMOVE ALL TEMPORARY EROSION CONTROL MEASURES UPON ESTABLISHMENT OF PERMANENT VEGETATION OR PROJECT COMPLETION.

13. SILT FENCE AND FLOATING TURBIDITY BARRIERS SHALL MEET THE REQUIREMENTS OF FDOT DESIGN STANDARDS FY 2024-25, SECTION 104.

14. CONTRACTOR SHALL BE SOLELY RESPONSIBLE FOR CONTROL OF EROSION WITHIN THE WORK SITE AND PREVENTION OF SEDIMENTATION OF ANY ADJACENT OR DOWNSTREAM WATERWAYS. THE EROSION AND SEDIMENTATION CONTROL MEASURES SHOWN ON THE PLANS ARE THE MINIMUM REQUIREMENTS. THE CONTRACTOR'S METHODS OF OPERATION MAY DICTATE ADDITIONAL EROSION AND SEDIMENTATION CONTROL MEASURES. THE CONTRACTOR SHALL BE RESPONSIBLE FOR DETERMINING AND INSTALLING ADDITIONAL MEASURES.

15. ANY DISTURBED AREA LEFT EXPOSED FOR A PERIOD GREATER THAN 20 DAYS SHALL BE STABILIZED WITH MULCH OR TEMPORARY SEEDING.

16. EROSION CONTROL MEASURES WILL BE MAINTAINED AT ALL TIMES. IF FULL IMPLEMENTATION OF THE APPROVED PLAN DOES NOT PROVIDE FOR EFFECTIVE EROSION CONTROL, ADDITIONAL EROSION AND SEDIMENT CONTROL MEASURES SHALL BE IMPLEMENTED TO CONTROL OR TREAT THE SEDIMENT SOURCE.

17. NOTIFY APPROPRIATE MANATEE COUNTY REPRESENTATIVE 72 HOURS PRIOR TO COMMENCEMENT OF CONSTRUCTION.

18. THE CONTRACTOR SHALL BE SOLE RESPONSIBLE FOR ENSURING ALL PERMIT REQUIREMENTS FOR TURBIDITY ARE MET. THE TURBIDITY LEVELS OUTSIDE THE PROJECT SHALL NOT EXCEED 0 NTU'S ABOVE BACKGROUND OR AS DICTATED BY THE PERMITS. THE TURBIDITY MONITORING WILL BE PERFORMED BY MANATEE COUNTY REPRESENTATIVE AND SHALL BE LOGGED DURING IN WATER WORK.

**C. EXISTING INFRASTRUCTURE**

1. THE CONTRACTOR IS RESPONSIBLE FOR REPLACING EXISTING INFRASTRUCTURE THAT IS IMPACTED DURING CONSTRUCTION TO MATCH EXISTING CONDITIONS. SEE CONSTRUCTION PLAN SHEET FOR DETAILS.

**D. PERMITTING NOTES**

1. PERMITTING UNDER 62-3300.630 GENERAL PERMIT FOR ENVIRONMENTAL ENHANCEMENT

2. IT IS PRESUMED THE ACTIVITIES DEFINED ARE ELIGIBLE FOR THIS PERMIT BASED ON THE FOLLOWING:

a. NO ACTIVITIES OCCUR ON SANDY BEACHES THAT FRONT THE ATLANTIC OCEAN, THE GULF OF MEXICO, OR THE STRAIGHTS OF FLORIDA.

b. NO MITIGATION FOR ANOTHER ACTIVITY IS PROPOSED

c. THE ACTIVITIES DO NOT INVOLVE REPLACING A NATURAL BIOLOGICAL COMMUNITY WITH A DIFFERENT TYPE.

d. THE ACTIVITIES DO NOT ADVERSELY AFFECT ANIMAL OR PLANT SPECIES THAT ARE LISTED AS ENDANGERED, THREATENED OR OF SPECIAL CONCERN.

e. ACTIVITIES PROPOSED DO NOT IMPACT HISTORICAL PROPERTIES DEFINED ON THE NATIONAL REGISTER OF HISTORICAL PLACES UNDER THE PROVISIONS OF SECTION 267.061, F.S.

f. THE ACTIVITIES ARE NOT PART OF THE CENTRAL AND SOUTHERN FLORIDA FLOOD CONTROL PROJECT, THEREFOR DO NOT REQUIRE A PERMIT UNDER SECTION 373.1502, F.S., NOR ARE ANY ACTIVITIES AUTHORIZED UNDER SECTION 528 OF THE WATER RESOURCES DEVELOPMENT ACT OF 1996, PUBLIC LAW 104-303 (CRITICAL RESTORATION PROJECTS), OCTOBER 12, 1996.

g. THE ACTIVITIES DO NOT MATCH ANY ACTIVITY AUTHORIZED UNDER SECTION 101(8) OF THE WATER RESOURCES DEVELOPMENT ACT OF 1992, PUBLIC LAW 102-580, (OCTOBER 31, 1992).

h. THE ACTIVITIES ARE PRESUMED TO NOT BE ASSOCIATED WITH EVERGLADES OR LAKE OKEECHOBEE RESTORATION.

3. GRANT FUNDING AND ASSOCIATED DOCUMENTS WILL BE INCLUDED WHICH INCLUDE JUSTIFICATION DOCUMENTATION.

4. ACTIVITIES UNDER THIS PERMIT ARE SUBJECT TO ADDITIONAL PROVISIONS AND LIMITATIONS AS FOLLOWS:

a. ACTIVITIES WILL NOT BE ELIGIBLE FOR USE AS FUTURE MITIGATION CREDIT FOR SEPARATE ACTIVITIES.

b. WILL NOT ADVERSELY AFFECT THE VALUE OF FUNCTIONS PROVIDED TO FISH AND WILDLIFE BY WETLANDS OR OTHER SURFACE WATERS.

c. WILL NOT CAUSE ADVERSE IMPACTS OUTLINED UNDER THIS SECTION.

d. THE DESIGN IS CAPABLE OF BEING PERFORMED AND FUNCTION AS PROPOSED

e. PRIMARY INTENT OF PROJECT IS TO ENHANCE THE AREAS RESILIENCY BY PROVIDING A COMBINATION OF HARDENED AND LIVING SHORELINE STABILIZATION.

5. REQUIRED DOCUMENTS WILL BE SUPPLIED WITH PERMIT APPLICATION.

a. COPY OF COASTAL ZONE CONSISTENCY CONCURRENCE

b. FEDERAL FUNDING AUTHORIZATION DOCUMENTATION

c. N/A - NO FLOCCULENT PROPOSED

d. N/A - NO MIXING ZONE IS REQUIRED

**E. PROTECTED SPECIES SIGHTINGS**

THE ACTION AGENCY AND ANY PERMITTEE SHALL ENSURE THAT ALL PERSONNEL ASSOCIATED WITH THE PROJECT ARE INSTRUCTED ABOUT THE POTENTIAL PRESENCE OF SPECIES PROTECTED UNDER THE ENDANGERED SPECIES ACT (ESA) AND THE MARINE MAMMAL PROTECTION ACT (MMPA). ALL ON-SITE PROJECT PERSONNEL ARE RESPONSIBLE FOR OBSERVING WATER-RELATED ACTIVITIES FOR THE PRESENCE OF PROTECTED SPECIES. ALL PERSONNEL SHALL BE ADVISED THAT THERE ARE CIVIL AND CRIMINAL PENALTIES FOR HARMING, HARASSING, OR KILLING LISTED SPECIES AND ALL MARINE MAMMALS. TO DETERMINE WHICH PROTECTED SPECIES AND CRITICAL HABITAT MAY BE FOUND IN THE TRANSIT AREA, PLEASE REVIEW THE RELEVANT MARINE MAMMAL AND ESA-LISTED SPECIES AT FIND A SPECIES (<https://www.fisheries.noaa.gov/findspecies>) AND THE CONSULTATION DOCUMENTS THAT HAVE BEEN COMPLETED FOR THE PROJECT.

**1. EQUIPMENT:**  
 TURBIDITY CURTAINS, IF USED, SHALL BE MADE OF MATERIAL IN WHICH PROTECTED SPECIES CANNOT BECOME ENTANGLED AND BE REGULARLY MONITORED TO AVOID PROTECTED SPECIES ENTRAPMENT. ALL TURBIDITY CURTAINS AND OTHER IN-WATER EQUIPMENT SHALL BE PROPERLY SECURED WITH MATERIALS THAT REDUCE THE RISK OF PROTECTED SPECIES ENTANGLEMENT AND ENTRAPMENT.

**A. IN-WATER LINES (ROPE, CHAIN, AND CABLE, INCLUDING THE LINES TO SECURE TURBIDITY CURTAINS) SHALL BE STIFF, TAUT, AND NON-LOOPING. EXAMPLES OF SUCH LINES ARE HEAVY METAL CHAINS OR HEAVY CABLES THAT DO NOT READILY LOOP AND TANGLE. FLEXIBLE IN-WATER LINES, SUCH AS NYLON ROPE OR ANY LINES THAT COULD LOOP OR TANGLE, SHALL BE ENCLOSED IN A PLASTIC OR RUBBER SLEEVE/TUBE TO ADD RIGIDITY AND PREVENT THE LINE FROM LOOPING AND TANGLING. IN ALL INSTANCES, NO EXCESS LINE SHALL BE ALLOWED IN THE WATER. ALL ANCHORING SHALL BE IN AREAS FREE FROM HARDBOTTOM AND SEAGRASS.**

**B. TURBIDITY CURTAINS AND OTHER IN-WATER EQUIPMENT SHALL BE PLACED IN A MANNER THAT DOES NOT ENTRAP PROTECTED SPECIES WITHIN THE PROJECT AREA AND MINIMIZES THE EXTENT AND DURATION OF THEIR EXCLUSION FROM THE PROJECT AREA.**

**C. TURBIDITY BARRIERS SHALL BE POSITIONED IN A WAY THAT MINIMIZES THE EXTENT AND DURATION OF PROTECTED SPECIES EXCLUSION FROM IMPORTANT HABITAT (E.G. CRITICAL HABITAT, HARDBOTTOM, SEAGRASS) IN THE PROJECT AREA.**

**2. OPERATIONS:**  
 FOR CONSTRUCTION WORK THAT IS GENERALLY STATIONARY (E.G., BARGE-MOUNTED EQUIPMENT DREDGING A BERTH OR SECTION OF RIVER, OR SHORE-BASED EQUIPMENT EXTENDING INTO THE WATER):

a. OPERATIONS OF MOVING EQUIPMENT SHALL CEASE IF A PROTECTED SPECIES IS OBSERVED WITHIN 150 FEET OF OPERATIONS.

b. ACTIVITIES SHALL NOT RESUME UNTIL THE PROTECTED SPECIES HAS DEPARTED THE PROJECT AREA OF ITS OWN VOLITION (E.G., SPECIES WAS OBSERVED DEPARTING OR 20 MINUTES HAVE PASSED SINCE THE ANIMAL WAS LAST SEEN IN THE AREA).

**3. VESSELS:**  
 FOR PROJECTS REQUIRING VESSELS, THE ACTION AGENCY, AND ANY PERMITTEE SHALL ENSURE CONDITIONS IN THE VESSEL STRIKE AVOIDANCE MEASURES ARE IMPLEMENTED AS PART OF THE PROJECT/PERMIT ISSUANCE (<https://www.fisheries.noaa.gov/southeast/consultations/regulations-policies-andguidance>).

**4. CONSULTATION REPORTING REQUIREMENT**  
 ANY INTERACTION WITH A PROTECTED SPECIES SHALL BE REPORTED IMMEDIATELY TO NOAA FISHERIES SERO PRD AND THE LOCAL AUTHORIZED STRANDING/RESCUE ORGANIZATION.

TO REPORT TO NOAA FISHERIES SERO PRD, SEND AN EMAIL TO [take-report-nmfsser@noaa.gov](mailto:take-report-nmfsser@noaa.gov). PLEASE INCLUDE THE SPECIES INVOLVED, THE CIRCUMSTANCES OF THE INTERACTION, THE FATE AND DISPOSITION OF THE SPECIES INVOLVED, PHOTOS (IF AVAILABLE), AND CONTACT INFORMATION FOR THE PERSON WHO CAN PROVIDE ADDITIONAL DETAILS IF REQUESTED. PLEASE INCLUDE THE PROJECT'S ENVIRONMENTAL CONSULTATION ORGANIZER (ECO) NUMBER AND PROJECT TITLE IN THE SUBJECT LINE OF EMAIL REPORTS.

TO REPORT THE INTERACTION TO THE LOCAL STRANDING/RESCUE ORGANIZATION, PLEASE SEE THE FOLLOWING WEBSITE FOR THE MOST UP TO DATE INFORMATION FOR REPORTING SICK, INJURED, OR DEAD PROTECTED SPECIES:  
 REPORTING VIOLATIONS:  
 TO REPORT AN ESA OR MMPA VIOLATION, CALL THE NOAA FISHERIES ENFORCEMENT HOTLINE. THIS HOTLINE IS AVAILABLE 24 HOURS A DAY, 7 DAYS WEEK FOR ANYONE IN THE UNITED STATES.

NOAA FISHERIES ENFORCEMENT HOTLINE: (800) 853-1964



5015 S. Florida Avenue, Suite 301  
 Lakeland, FL 33813  
 P+ 1 863-667-2345  
 wsp.com

GREGORY CORNING  
 FLORIDA PE LICENSE NO. 79293

**PROJECT:**  
**BISHOP POINT LIVING SHORELINE DESIGN AND PERMITTING**  
 BRADENTON, FLORIDA

**MANATEE COUNTY**  
 1112 Manatee Avenue West  
 Bradenton, FL 34205

**WSP PROJECT NO:**  
 600865X4

**100% FOR PERMITTING & BIDDING**

REVISIONS			
NO.	DATE	BY	APPROVED

DESIGNED BY:	---
DRAWN BY:	---
CHECKED BY:	---
APPROVED BY:	---
DATE:	7/30/25

**SHEET TITLE:**  
 GENERAL NOTES

<b>SHEET NUMBER:</b>	<b>REV. #</b>
<b>G-001</b>	<b>-</b>
SHEET 1 OF - SHEETS	

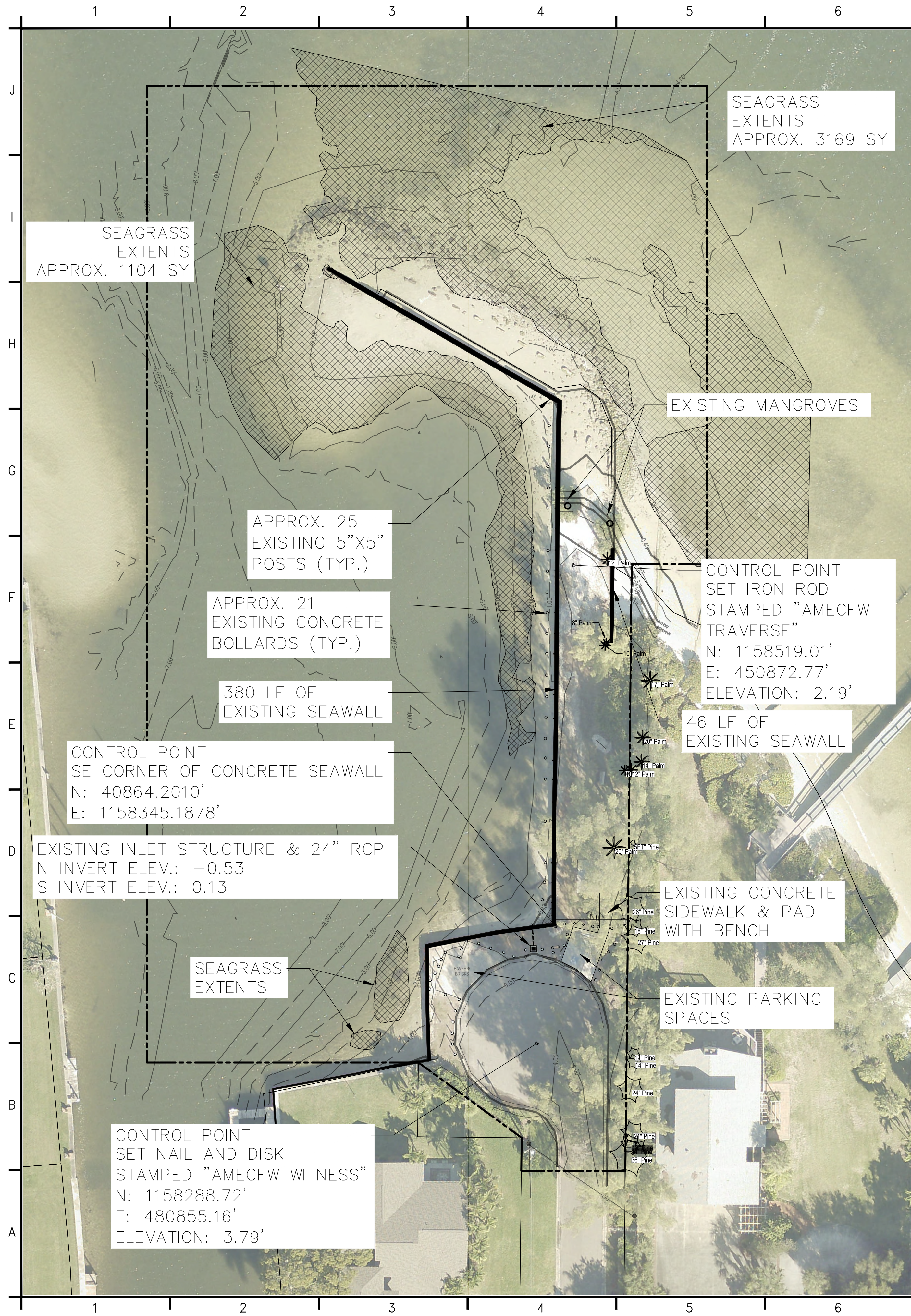

- LEGEND**
- 90% SEAGRASS EXTENTS
  - 15% SEAGRASS EXTENTS
  - EXISTING CONTOURS
  - EXISTING TREES

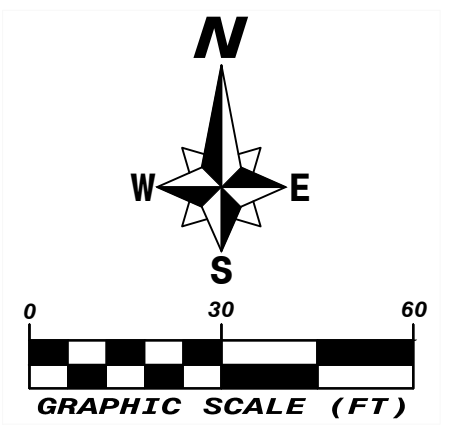
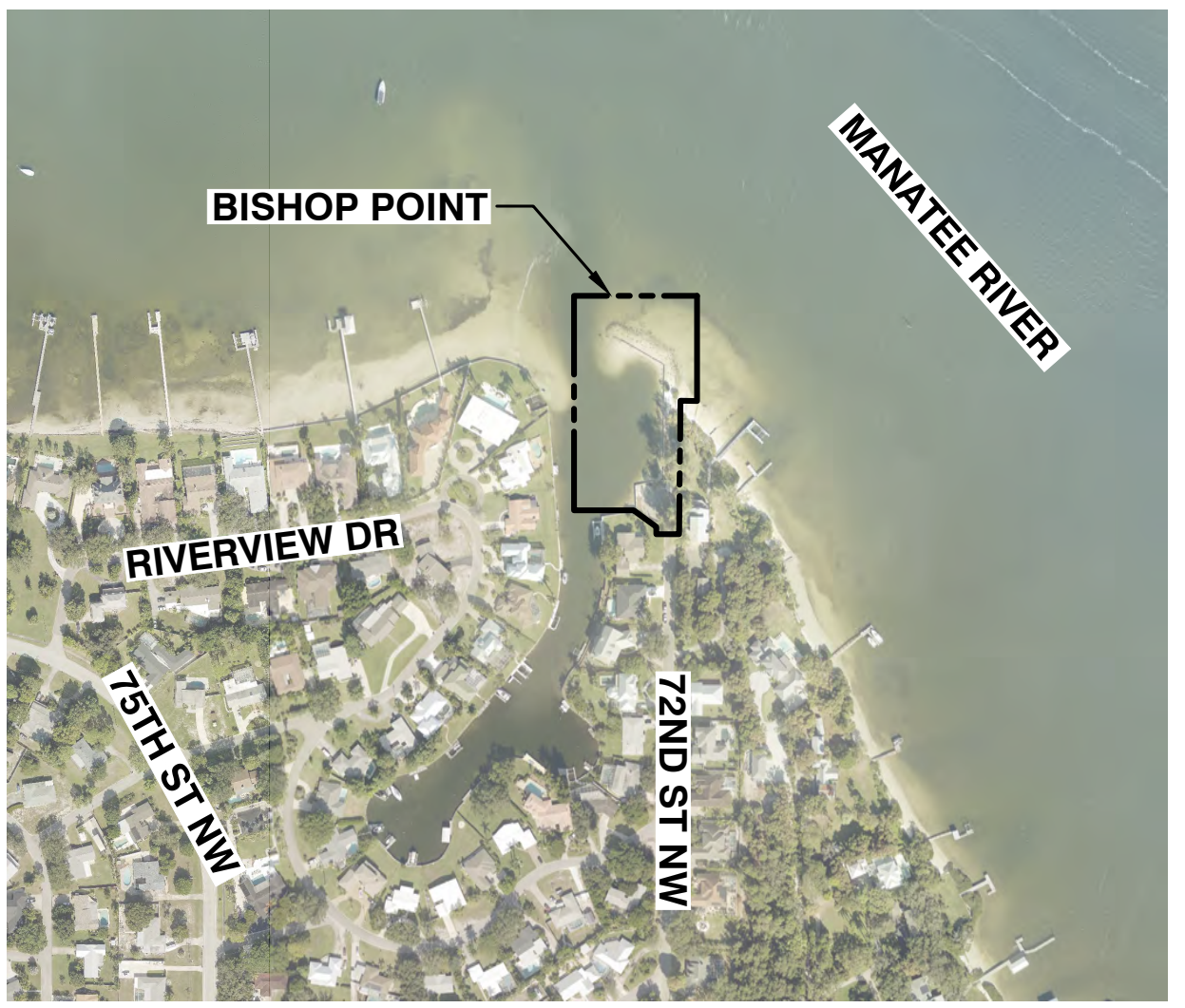

**wsp**

5015 S. Florida Avenue, Suite 301  
Lakeland, FL 33813  
P+ 1 863-667-2345  
wsp.com

GREGORY CORNING  
FLORIDA PE LICENSE NO. 79293

**PROJECT:**  
**BISHOP POINT LIVING SHORELINE DESIGN AND PERMITTING**

BRADENTON, FLORIDA

**MANATEE COUNTY**

1112 Manatee Avenue West  
Bradenton, FL 34205

**WSP PROJECT NO:**  
**600865X4**

**100% FOR PERMITTING & BIDDING**

REVISIONS			
NO.	DATE	BY	APPROVED

DESIGNED BY:	---
DRAWN BY:	---
CHECKED BY:	---
APPROVED BY:	---
DATE:	7/30/25

**SHEET TITLE:**

**EXISTING SITE PLAN**

<b>SHEET NUMBER:</b>	<b>REV. #</b>
<b>C-101</b>	<b>-</b>
<b>SHEET 1 OF - SHEETS</b>	





**LEGEND**  
 EXTENTS OF REMOVAL  
 EXISTING TREES

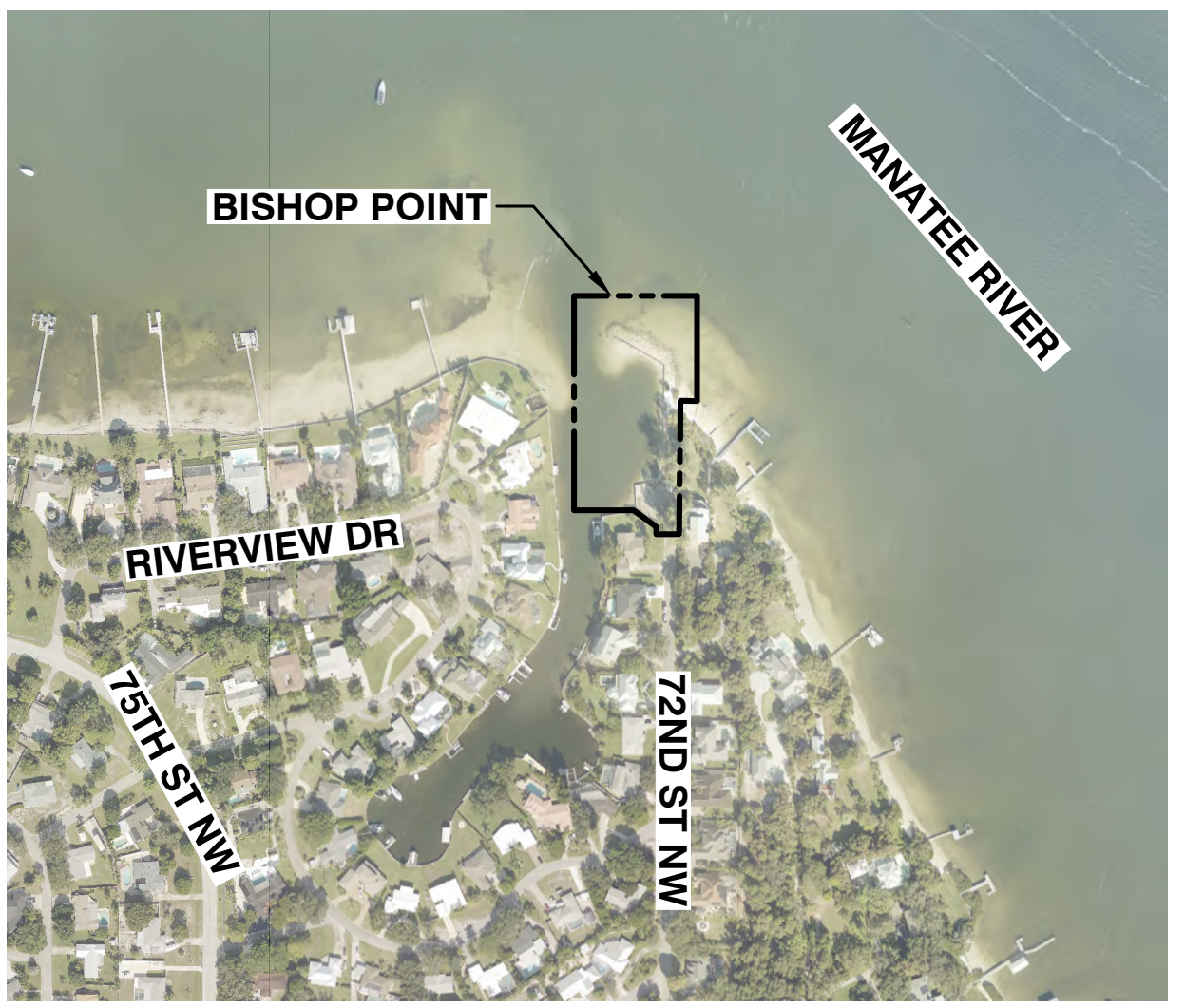

NOTE:  
 MATERIAL REMOVED FOR SLOPED SHORELINE, BIOSWALE, AND WALKING PATH IS ANTICIPATED AT APPROXIMATELY 100 CY.

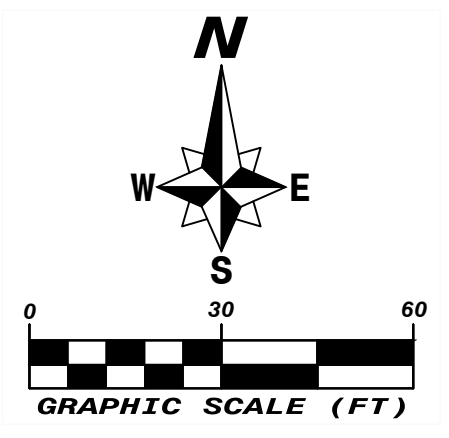

**wsp**  
 5015 S. Florida Avenue, Suite 301  
 Lakeland, FL 33813  
 P+ 1 863-667-2345  
 wsp.com

GREGORY CORNING  
 FLORIDA PE LICENSE NO. 79293

**PROJECT:**  
**BISHOP POINT LIVING SHORELINE DESIGN AND PERMITTING**  
 BRADENTON, FLORIDA

**MANATEE COUNTY**  
 1112 Manatee Avenue West  
 Bradenton, FL 34205

WSP PROJECT NO:  
 600865X4

**100% FOR PERMITTING & BIDDING**

REVISIONS			
NO.	DATE	BY	APPROVED

DESIGNED BY:	---
DRAWN BY:	---
CHECKED BY:	---
APPROVED BY:	---
DATE:	7/30/25

SHEET TITLE:  
**DEMOLITION PLAN**

SHEET NUMBER:	REV. #
<b>C-102</b>	-
SHEET 1 OF - SHEETS	

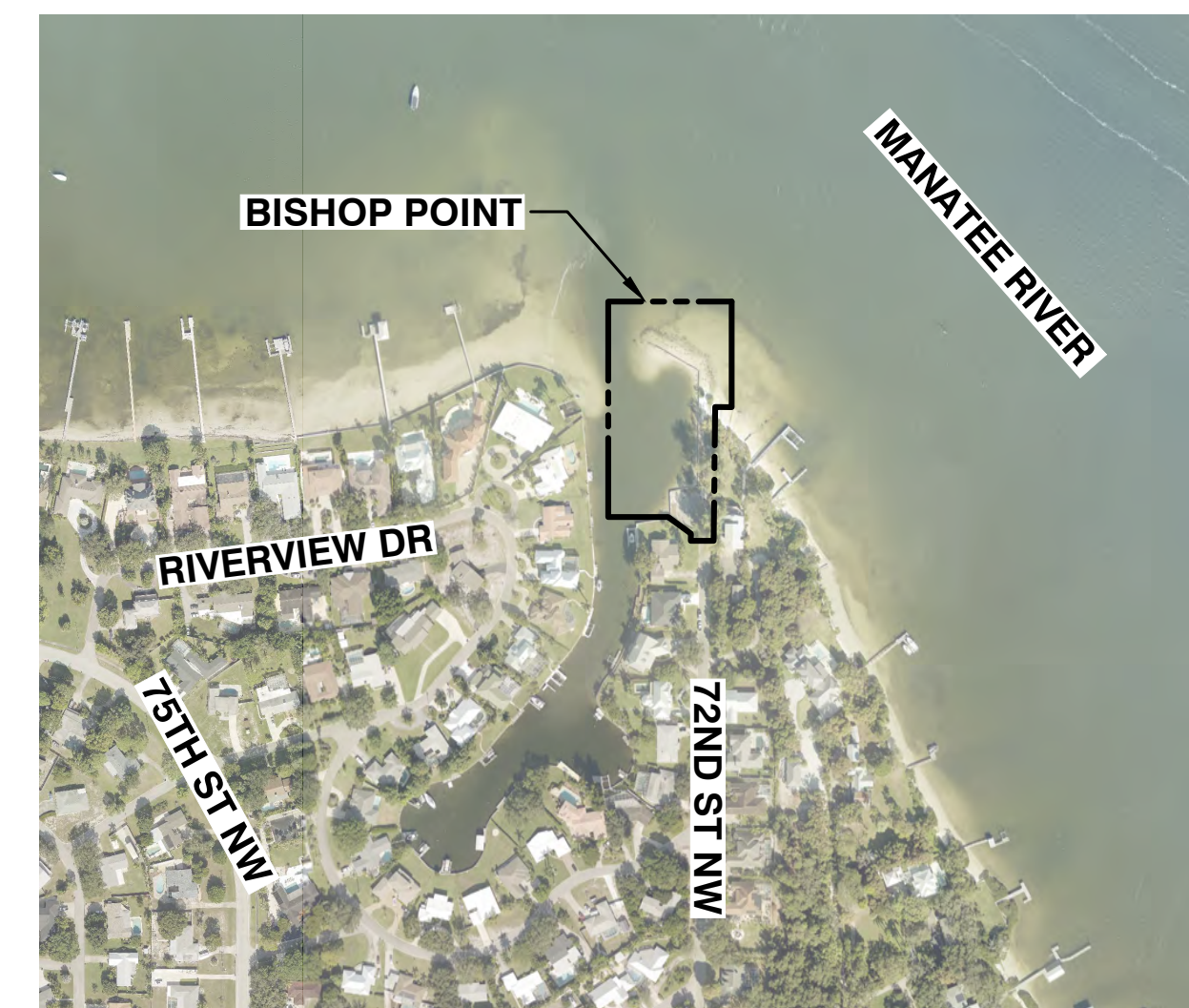
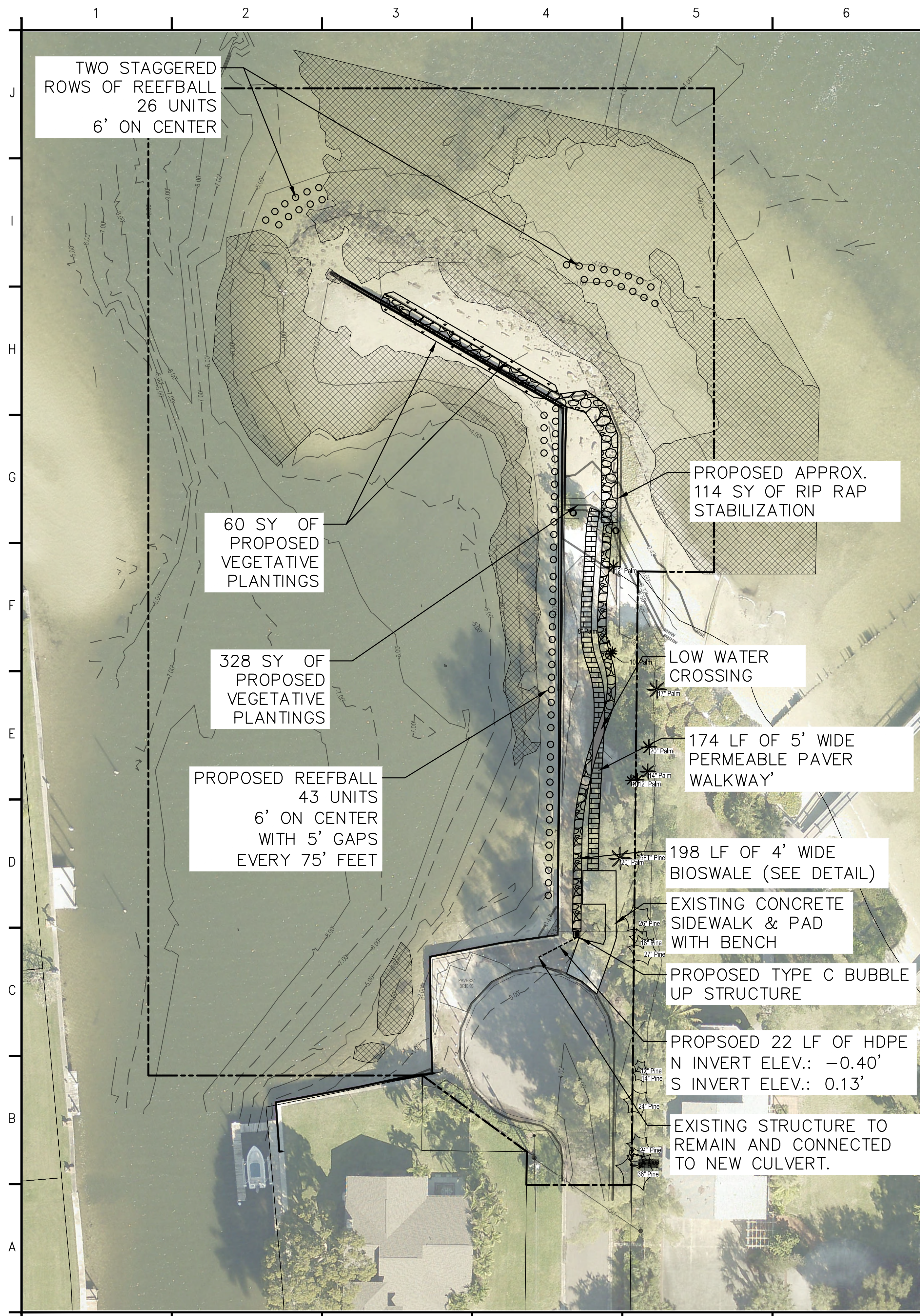

NOTE: MATERIAL REMOVED FOR SLOPED SHORELINE, BIOSWALE, AND WALKING PATH IS ANTICIPATED AT APPROXIMATELY 100 CY.

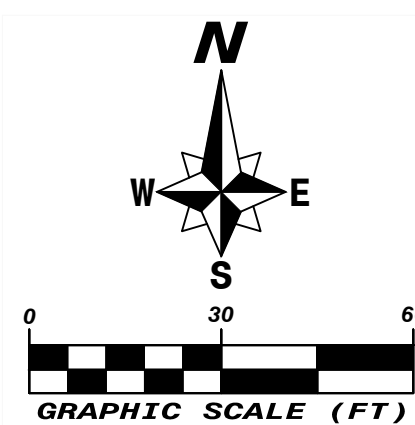

**wsp**

5015 S. Florida Avenue, Suite 301  
Lakeland, FL 33813  
P+ 1 863-667-2345  
wsp.com

GREGORY CORNING  
FLORIDA PE LICENSE NO. 79293

**PROJECT:**  
**BISHOP POINT LIVING SHORELINE DESIGN AND PERMITTING**

BRADENTON, FLORIDA



**MANATEE COUNTY**

1112 Manatee Avenue West  
Bradenton, FL 34205

**WSP PROJECT NO:**  
**600865X4**

**100% FOR PERMITTING & BIDDING**

REVISIONS			
NO.	DATE	BY	APPROVED

DESIGNED BY:	---
DRAWN BY:	---
CHECKED BY:	---
APPROVED BY:	---
DATE:	7/30/25

**SHEET TITLE:**  
**PROPOSED SITE PLAN**

<b>SHEET NUMBER:</b>	<b>REV. #</b>
<b>C-103</b>	<b>-</b>
<b>SHEET 1 OF - SHEETS</b>	

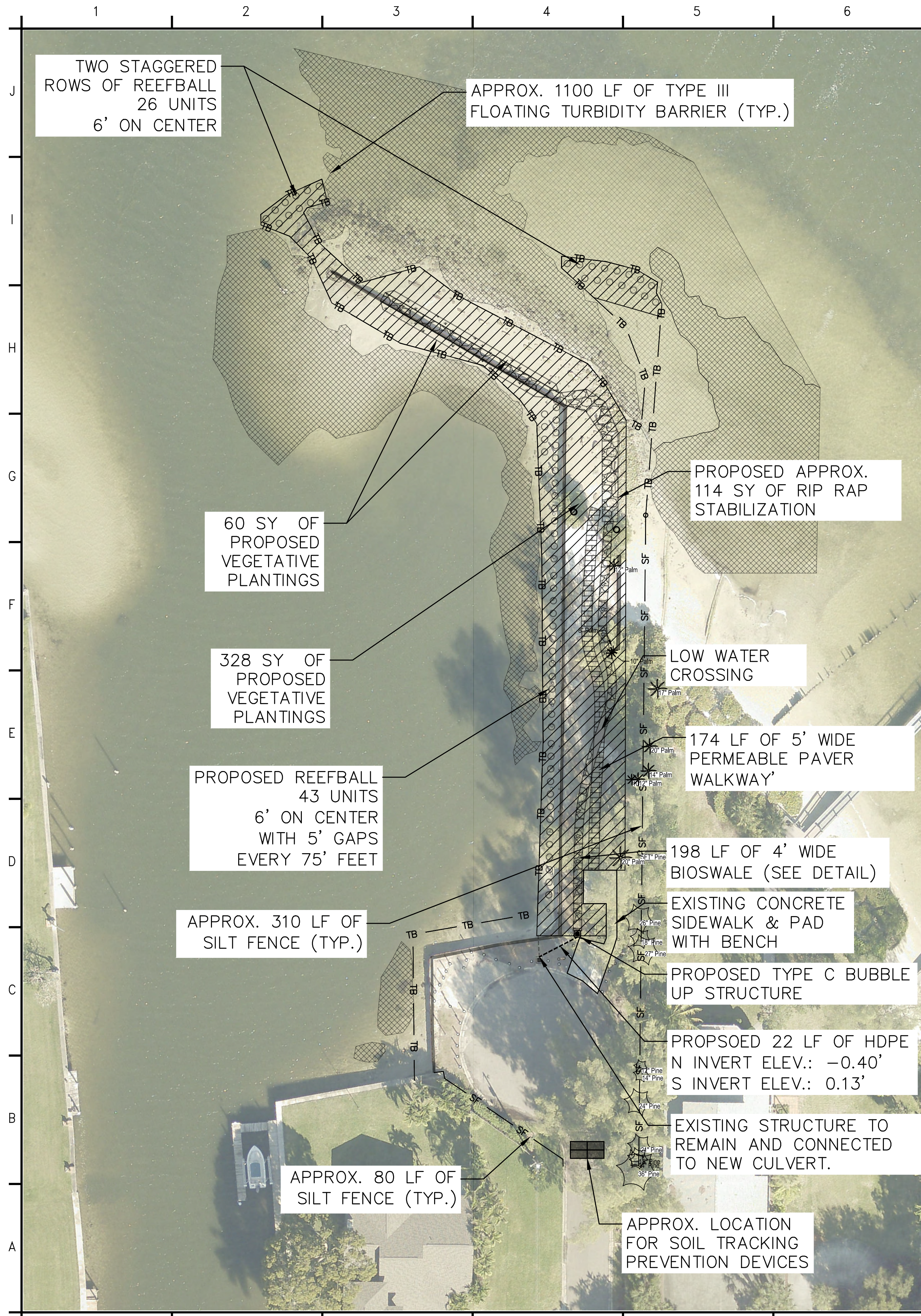

- LEGEND**
- RIP RAP
  - VEGETATED SLOPES
  - CONCRETE
  - PERVIOUS PAVERS
  - REEF BALLS
  - 90% SEAGRASS EXTENTS
  - 15% SEAGRASS EXTENTS
  - EXTENTS OF REMOVAL
  - SILT FENCE
  - TURBIDITY BARRIER
  - EXISTING TREES

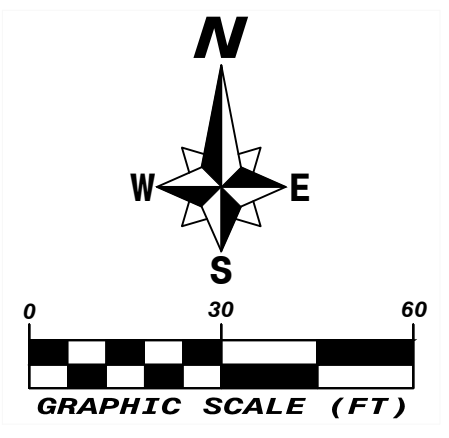
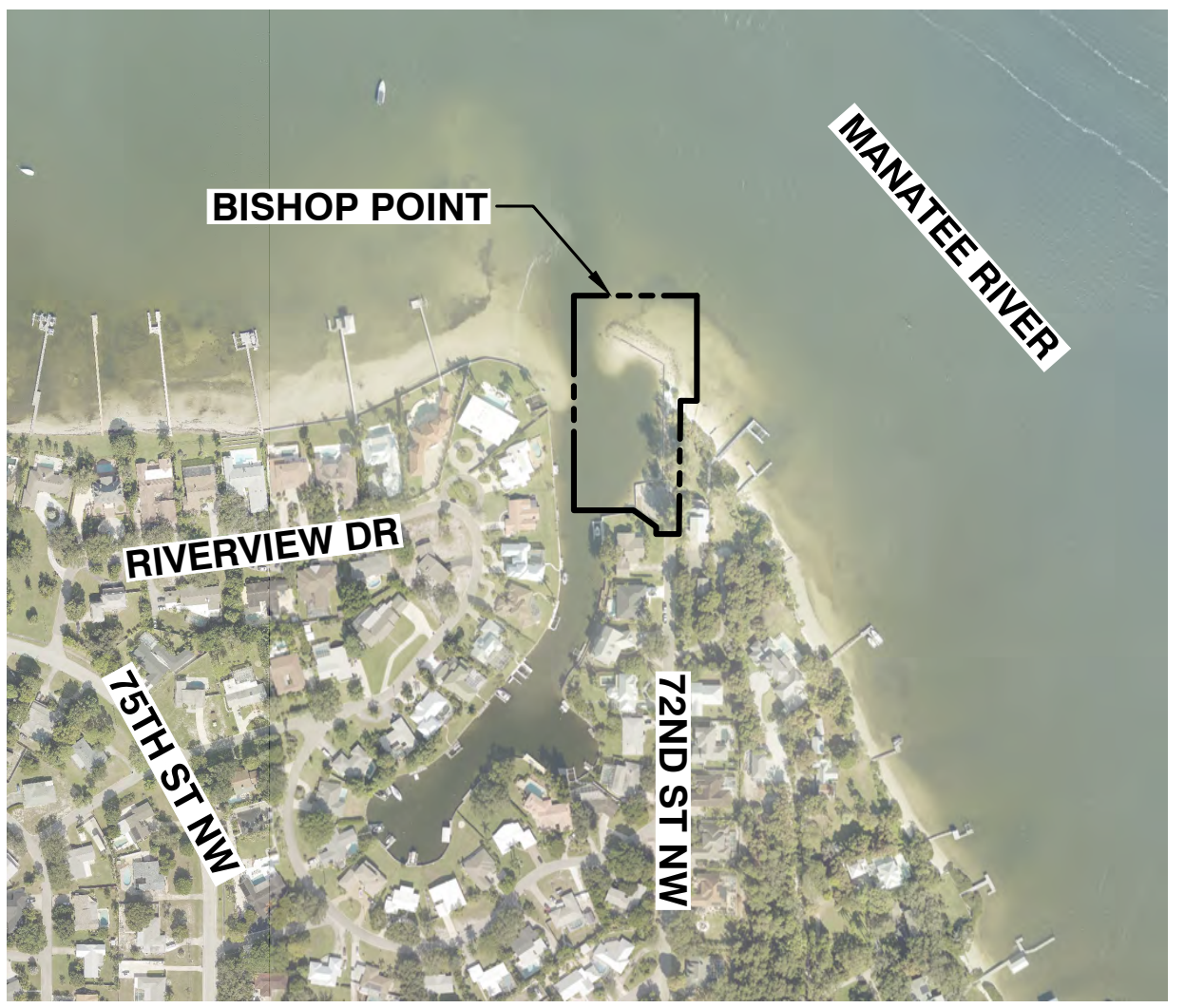

**wsp**

5015 S. Florida Avenue, Suite 301  
Lakeland, FL 33813  
P+ 1 863-667-2345  
wsp.com

GREGORY CORNING  
FLORIDA PE LICENSE NO. 79293

**PROJECT:**  
**BISHOP POINT LIVING SHORELINE DESIGN AND PERMITTING**



**MANATEE COUNTY**  
1112 Manatee Avenue West  
Bradenton, FL 34205

**WSP PROJECT NO:**  
**600865X4**

**100% FOR PERMITTING & BIDDING**

REVISIONS			
NO.	DATE	BY	APPROVED

DESIGNED BY:	---
DRAWN BY:	---
CHECKED BY:	---
APPROVED BY:	---
DATE:	7/30/25

**SHEET TITLE:**  
**EROSION AND SEDIMENT CONTROLS PLAN**

<b>SHEET NUMBER:</b>	<b>REV. #</b>
<b>C-104</b>	<b>-</b>
<b>SHEET 1 OF - SHEETS</b>	

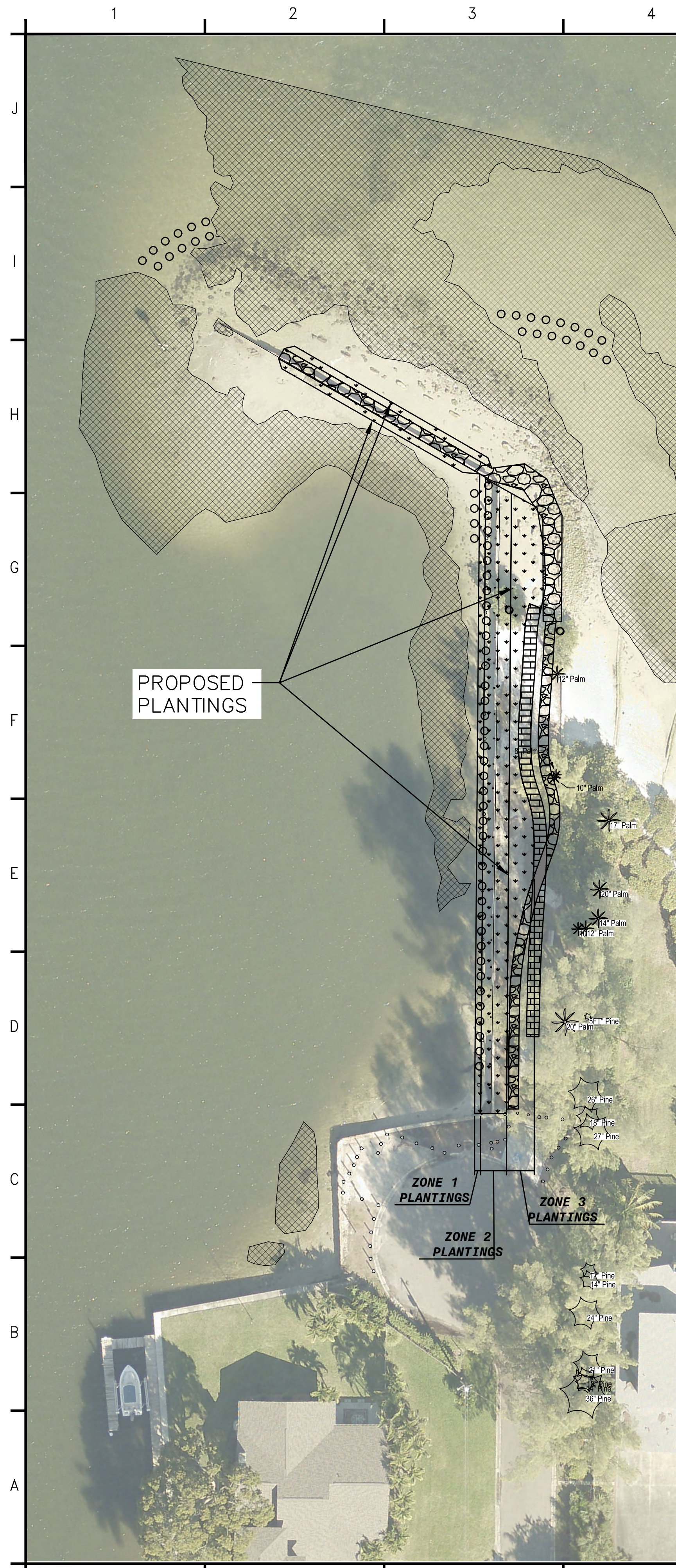

- LEGEND**
- RIP RAP
  - VEGETATED SLOPES
  - CONCRETE
  - PERVIOUS PAVERS
  - REEF BALLS
  - 90% SEAGRASS EXTENTS
  - 15% SEAGRASS EXTENTS
  - EXTENTS OF REMOVAL
  - SILT FENCE
  - TURBIDITY BARRIER
  - EXISTING TREES

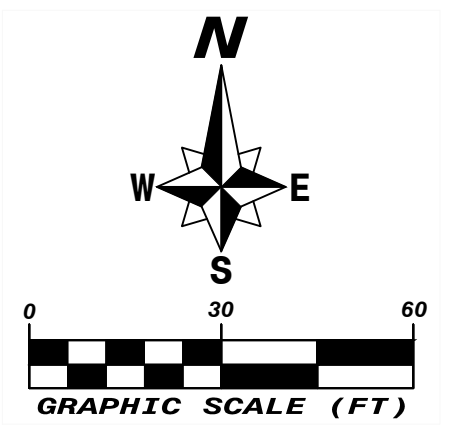
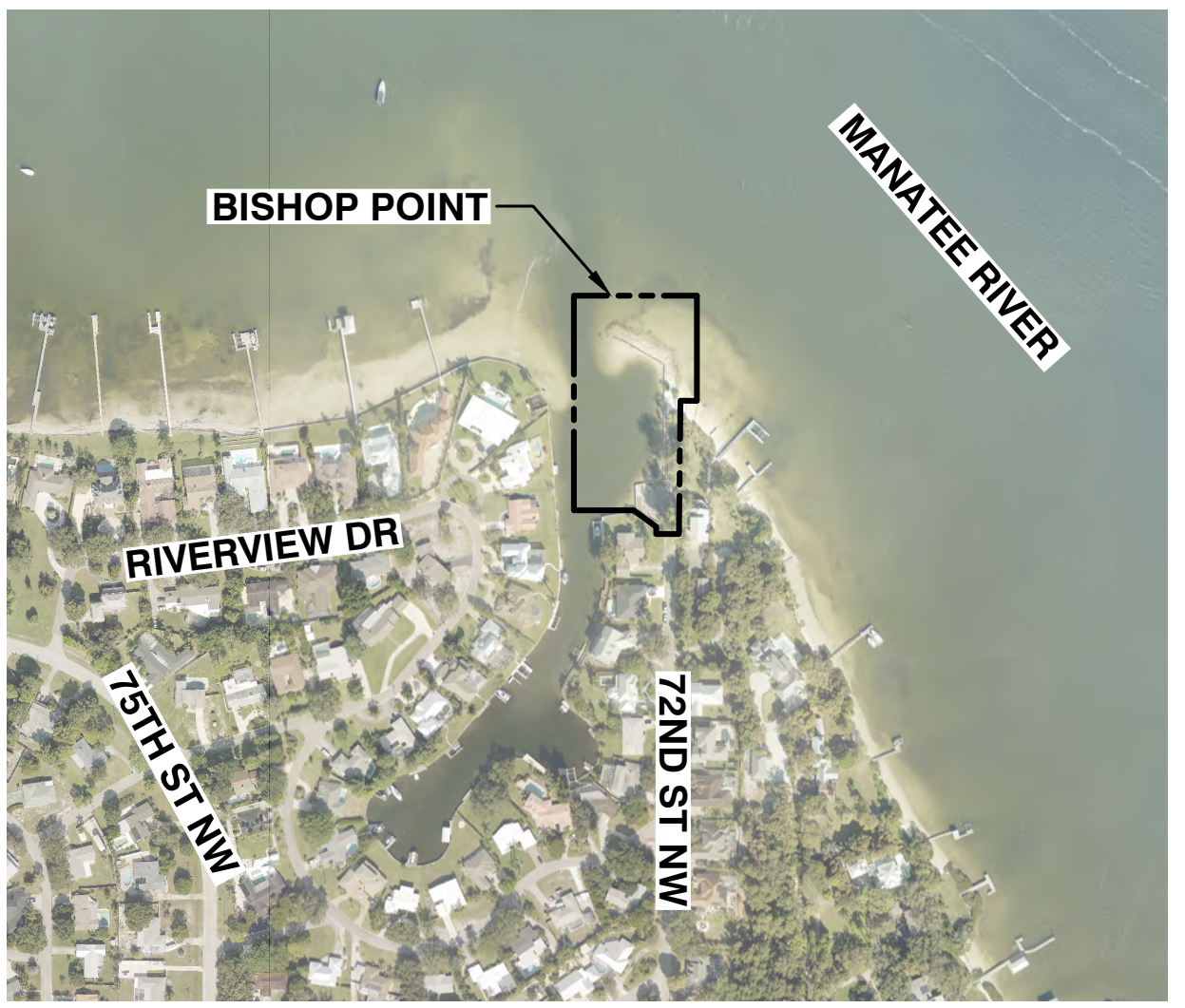

**wsp**

5015 S. Florida Avenue, Suite 301  
Lakeland, FL 33813  
P+ 1 863-667-2345  
wsp.com

GREGORY CORNING  
FLORIDA PE LICENSE NO. 79293

**PROJECT:**  
**BISHOP POINT LIVING SHORELINE DESIGN AND PERMITTING**

BRADENTON, FLORIDA

**MANATEE COUNTY**

1112 Manatee Avenue West  
Bradenton, FL 34205

**WSP PROJECT NO:**  
**600865X4**

**100% FOR PERMITTING & BIDDING**

Elevation Range for Planting (NAVD88)	Zone Name	Area (SQ FT)	Common Name	Scientific Name	Installation Size	Min. Spacing (in)	Percent Coverage	Quantity	Unit	Comments
Below MSL (-0.43)	Zone 1 - Subtidal	400	Turtle Grass	<i>Thalassia testudinum</i>	--	--	--	--	--	Recruitment Only
			Shoal Grass	<i>Halodule wrightii</i>	--	--	--	--	--	
			Manatee Grass	<i>Syringodium filiforme</i>	--	--	--	--	--	
MSL to TOB (-0.43 to 1.47/2.25)	Zone 2 - Slope	1435	Red Mangroves	<i>Rhizophora mangle</i>	--	--	--	--	EA	Recruitment Only
			Black Mangroves	<i>Avicennia germinans</i>	--	--	--	--	EA	
			Saltmarsh Bullrush	<i>Schoenoplectus robustus</i>	4" LN	12" OC	10%	100		Slope
			Black Needlerush	<i>Juncus roemerianus</i>	4" LN	12" OC	10%	100		
			Saltmarsh Cordgrass	<i>Sporobolus alternifolrus (aka Spartina alterniflora)</i>	4" LN	12" OC	60%	560		
			Saltmeadow Cordgrass	<i>Sporobolus pumilus (aka Spartina patens)</i>	4" LN	12" OC	20%	185		
TOB (1.47/2.25)	Zone 3 - Top of Bank	712	Seagrape	<i>Coccoloba uvifera</i>	1 G	--	10%	7	EA	Cluster of three (3) every 25ft.
			Buttonwood	<i>Conocarpus erectus</i>	1 G	--	10%	7	EA	
			Seaside Goldenrod	<i>Solidago sempervirens</i>	1 G	24" OC	10%	18	EA	Upper elevation limits
			Canada Goldenrod	<i>Solidago canadensis</i>	1 G	24" OC	10%	18	EA	
			Saltmeadow Cordgrass	<i>Sporobolus pumilus (aka Spartina patens)</i>	4" LN	12" OC	10%	45	EA	Slope
			Sea Ox-eye Daisy	<i>Borrichia frutescens</i>	4" LN	12" OC	10%	45	EA	
			Saltwort	<i>Batis maritima</i>	4" LN	12" OC	10%	45	EA	
			Sea Purslane	<i>Sesuvium portulacastrum</i>	4" LN	12" OC	10%	45	EA	
			Knot Grass	<i>Paspalum vaginatum</i>	4" LN	12" OC	20%	90	EA	
Zone 4 - Swale	716	Upper Edge	Sand Cordgrass	<i>Sporobolus bakeri (aka Spartina bakeri)</i>	4" LN	12" OC	10%	45	EA	
			Sea Purslane	<i>Sesuvium portulacastrum</i>	4" LN	12" OC	10%	45	EA	
		Slope	Sea Ox-eye Daisy	<i>Borrichia frutescens</i>	4" LN	24" OC	20%	62	EA	
			Saltmeadow Cordgrass	<i>Sporobolus pumilus (aka Spartina patens)</i>	4" LN	12" OC	20%	122	EA	
			Canada Goldenrod	<i>Solidago canadensis</i>	1 G	12" OC	20%	36	EA	
			Knot Grass	<i>Paspalum vaginatum</i>	4" LN	12" OC	10%	45	EA	
Recruitment Only	Sawgrass	<i>Cladium jamaicense</i>	4" LN	12" OC	10%	45	EA			

REVISIONS			
NO.	DATE	BY	APPROVED

DESIGNED BY:	---
DRAWN BY:	---
CHECKED BY:	---
APPROVED BY:	---
DATE:	7/30/25

**SHEET TITLE:**

**PLANTING PLAN**

<b>SHEET NUMBER:</b>	<b>REV. #</b>
<b>C-105</b>	<b>-</b>
<b>SHEET 1 OF - SHEETS</b>	

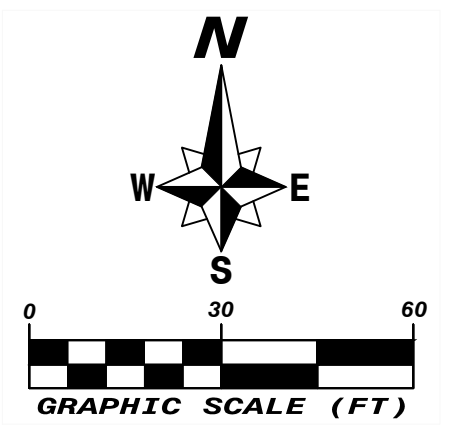
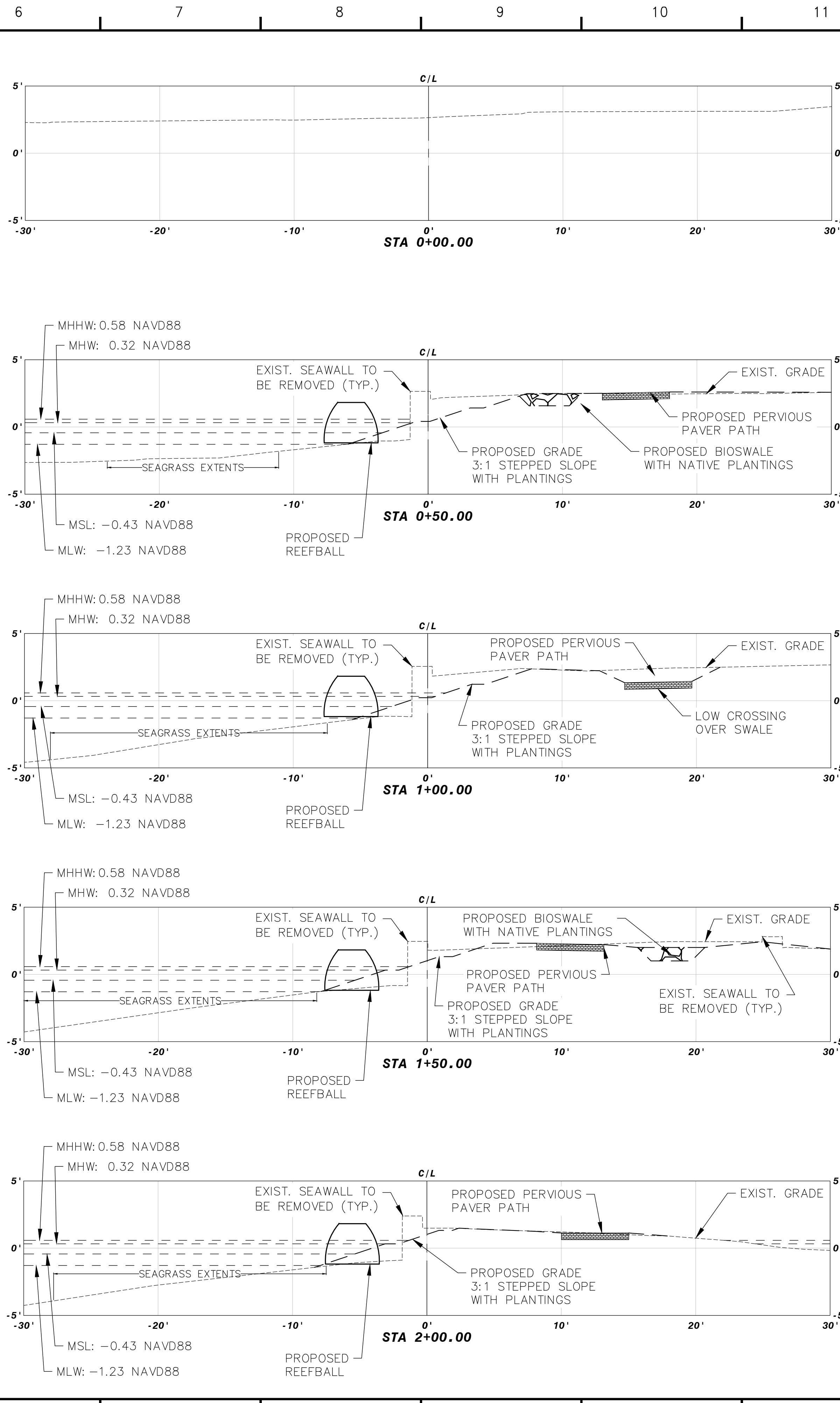

**wsp**

5015 S. Florida Avenue, Suite 301  
Lakeland, FL 33813  
P+ 1 863-667-2345  
wsp.com

GREGORY CORNING  
FLORIDA PE LICENSE NO. 79293

**PROJECT:**  
**BISHOP POINT LIVING**  
**SHORELINE DESIGN**  
**AND PERMITTING**



**MANATEE COUNTY**

1112 Manatee Avenue West  
Bradenton, FL 34205

**WSP PROJECT NO:**  
**600865X4**

**100% FOR PERMITTING & BIDDING**

REVISIONS			
NO.	DATE	BY	APPROVED

DESIGNED BY:	---
DRAWN BY:	---
CHECKED BY:	---
APPROVED BY:	---
DATE:	7/30/25

**SHEET TITLE:**

**CROSS SECTION**  
**1 OF 2**

<b>SHEET NUMBER:</b>	<b>REV. #</b>
<b>C-301</b>	<b>-</b>
<b>SHEET 1 OF - SHEETS</b>	

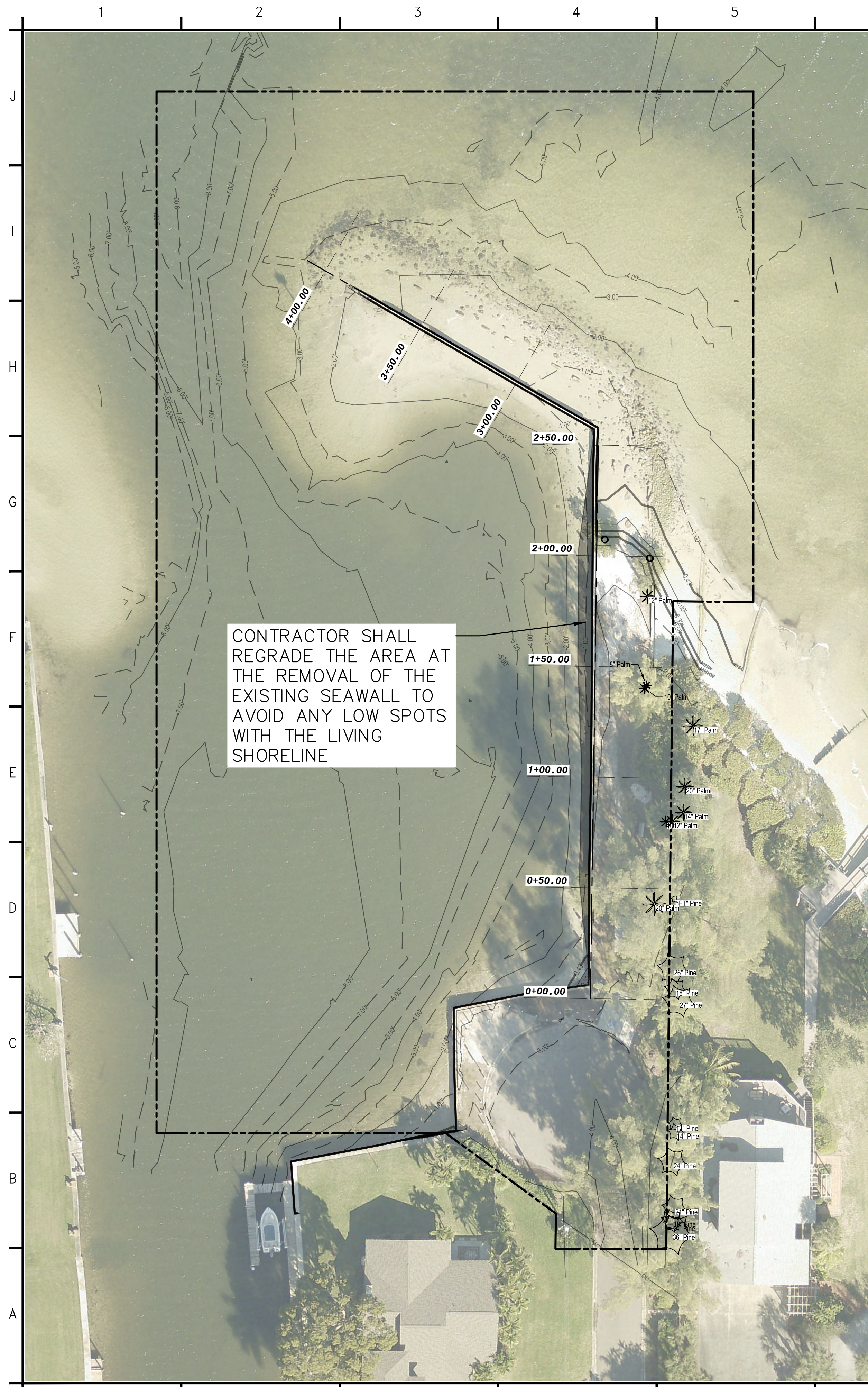

CONTRACTOR SHALL  
REGRADE THE AREA AT  
THE REMOVAL OF THE  
EXISTING SEAWALL TO  
AVOID ANY LOW SPOTS  
WITH THE LIVING  
SHORELINE

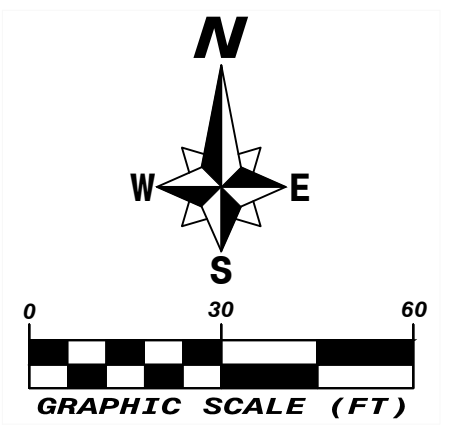
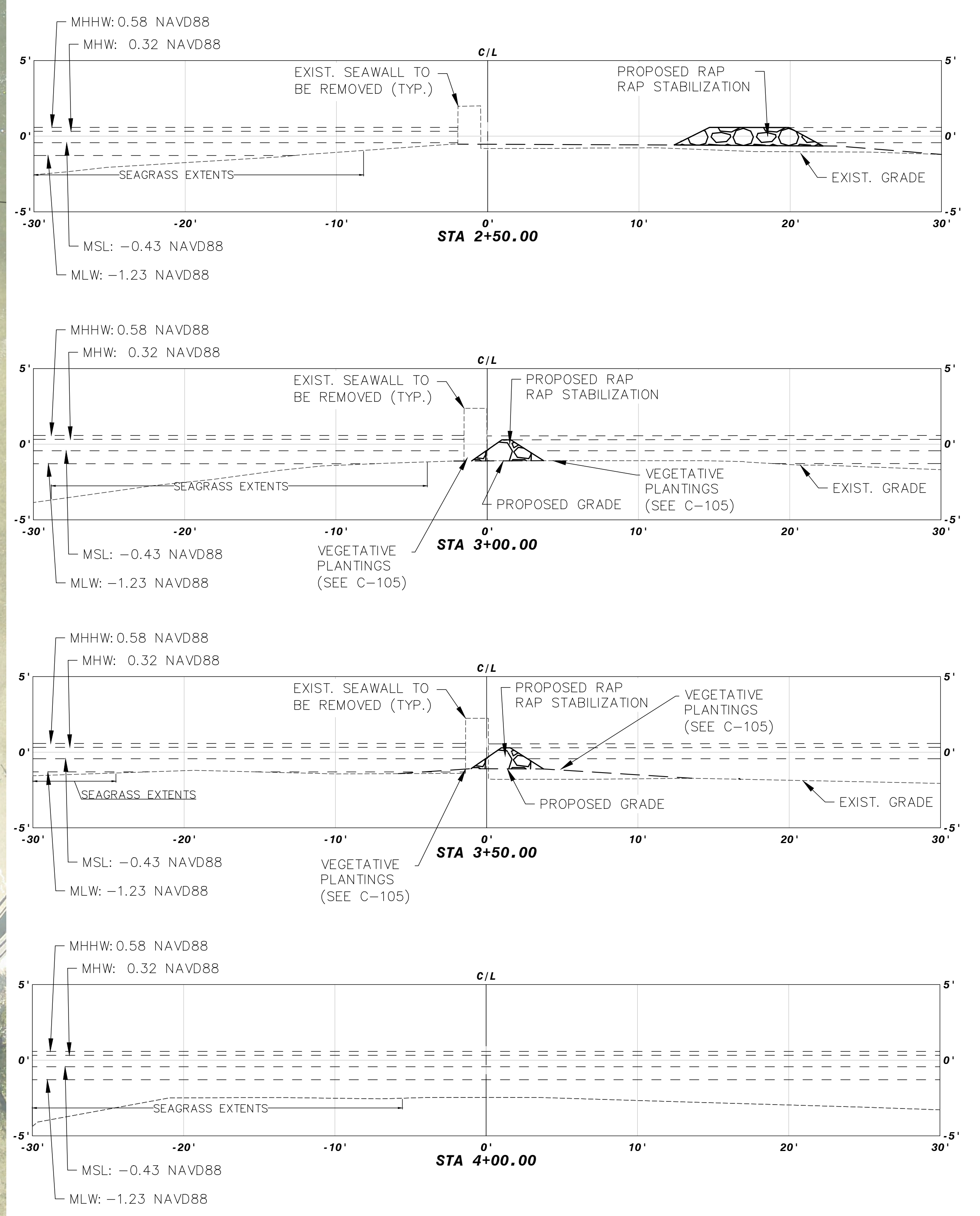

**wsp**

5015 S. Florida Avenue, Suite 301  
Lakeland, FL 33813  
P+ 1 863-667-2345  
wsp.com

GREGORY CORNING  
FLORIDA PE LICENSE NO. 79293

**PROJECT:  
BISHOP POINT LIVING  
SHORELINE DESIGN  
AND PERMITTING**

BRADENTON, FLORIDA



**MANATEE COUNTY**

1112 Manatee Avenue West  
Bradenton, FL 34205

WSP PROJECT NO:  
600865X4

**100% FOR PERMITTING & BIDDING**

REVISIONS			
NO.	DATE	BY	APPROVED

DESIGNED BY:	---
DRAWN BY:	---
CHECKED BY:	---
APPROVED BY:	---
DATE:	7/30/25

SHEET TITLE:  
  
**CROSS SECTION  
2 OF 2**

SHEET NUMBER:	REV. #
<b>C-302</b>	-
SHEET 1 OF - SHEETS	

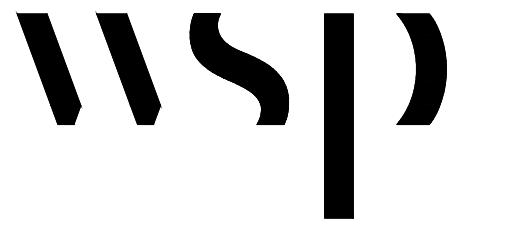
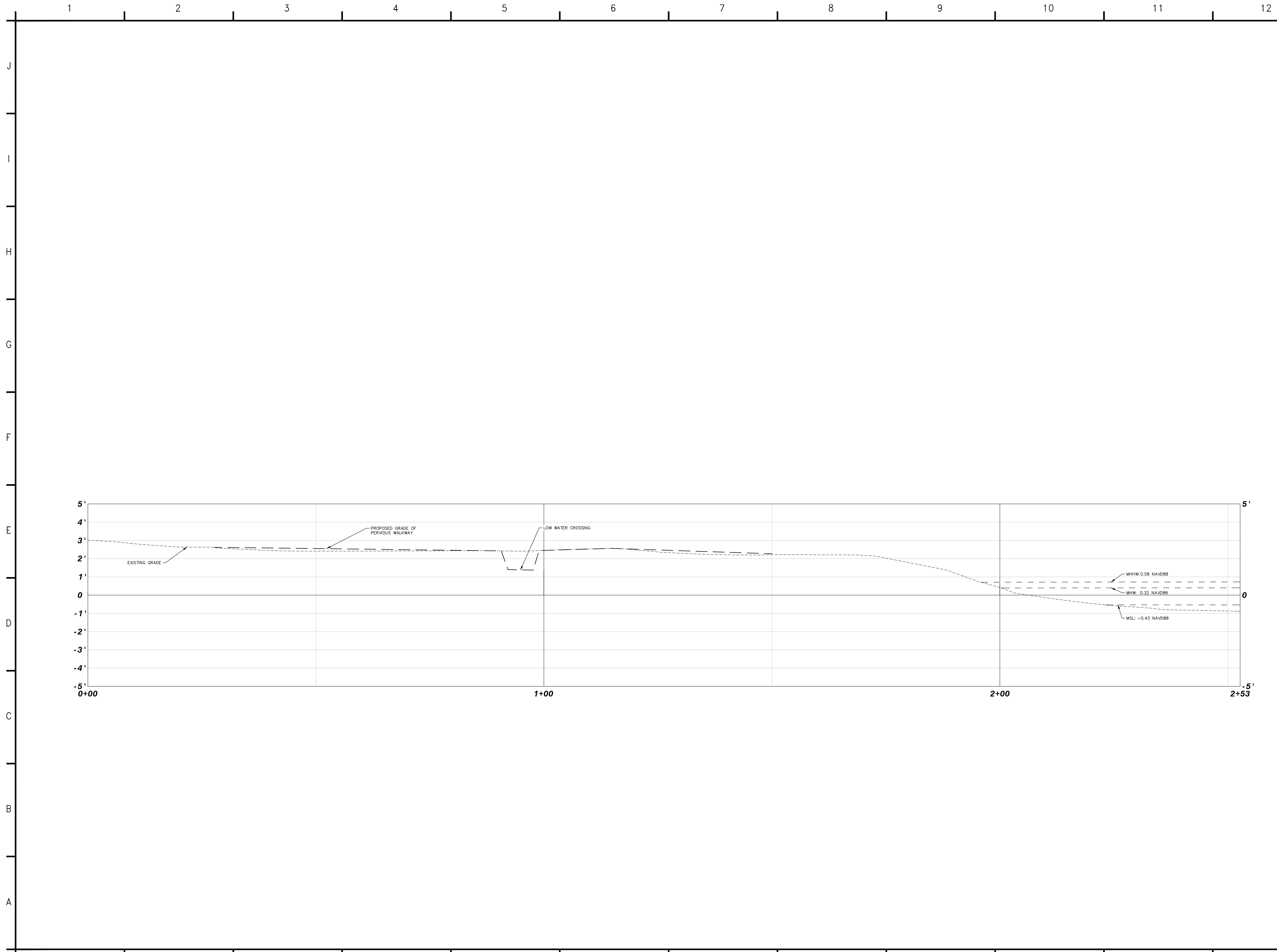

5015 S. Florida Avenue, Suite 301  
Lakeland, FL 33813  
P+ 1 863-667-2345  
wsp.com

GREGORY CORNING  
FLORIDA PE LICENSE NO. 79293

PROJECT:  
**BISHOP POINT LIVING  
SHORELINE DESIGN  
AND PERMITTING**

BRADENTON, FLORIDA



**MANATEE COUNTY**

1112 Manatee Avenue West  
Bradenton, FL 34205

WSP PROJECT NO:  
**600865X4**

**100% FOR PERMITTING & BIDDING**

REVISIONS			
NO.	DATE	BY	APPROVED

DESIGNED BY:	---
DRAWN BY:	---
CHECKED BY:	---
APPROVED BY:	---
DATE:	7/30/25

SHEET TITLE:  
  
**SIDEWALK PROFILE**

SHEET NUMBER:	REV. #
<b>C-303</b>	-
SHEET 1 OF - SHEETS	

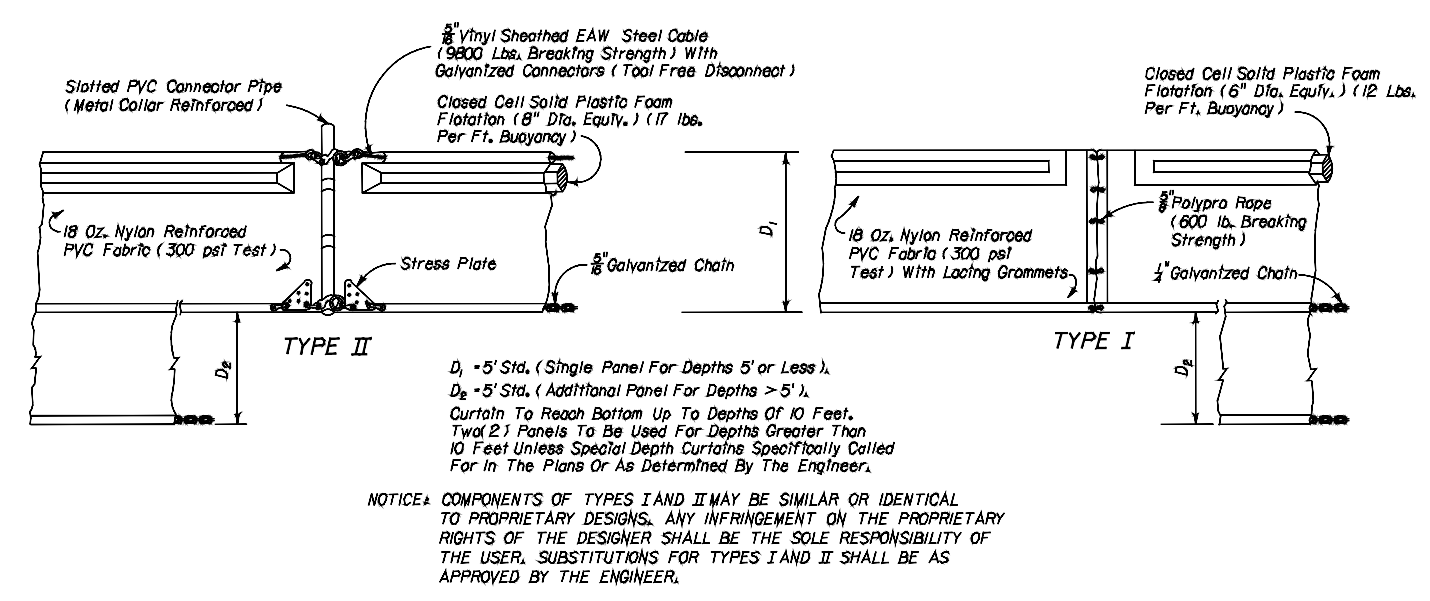

**FLOATING TURBIDITY BARRIERS**  
NTS

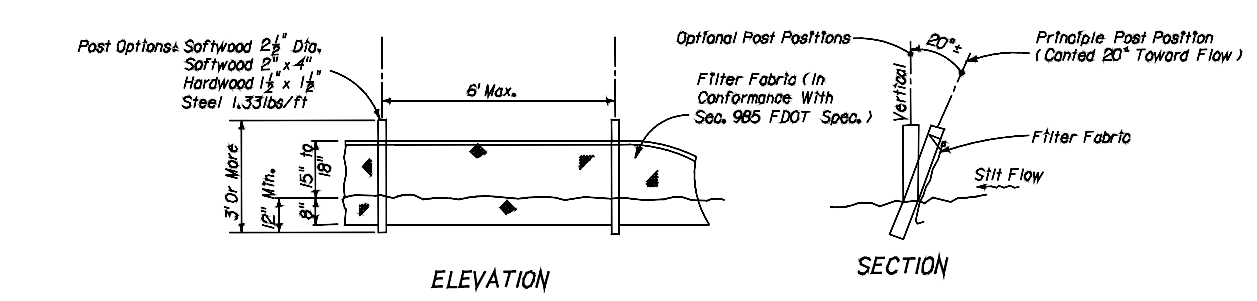

**TYPE III SILT FENCE**  
NTS

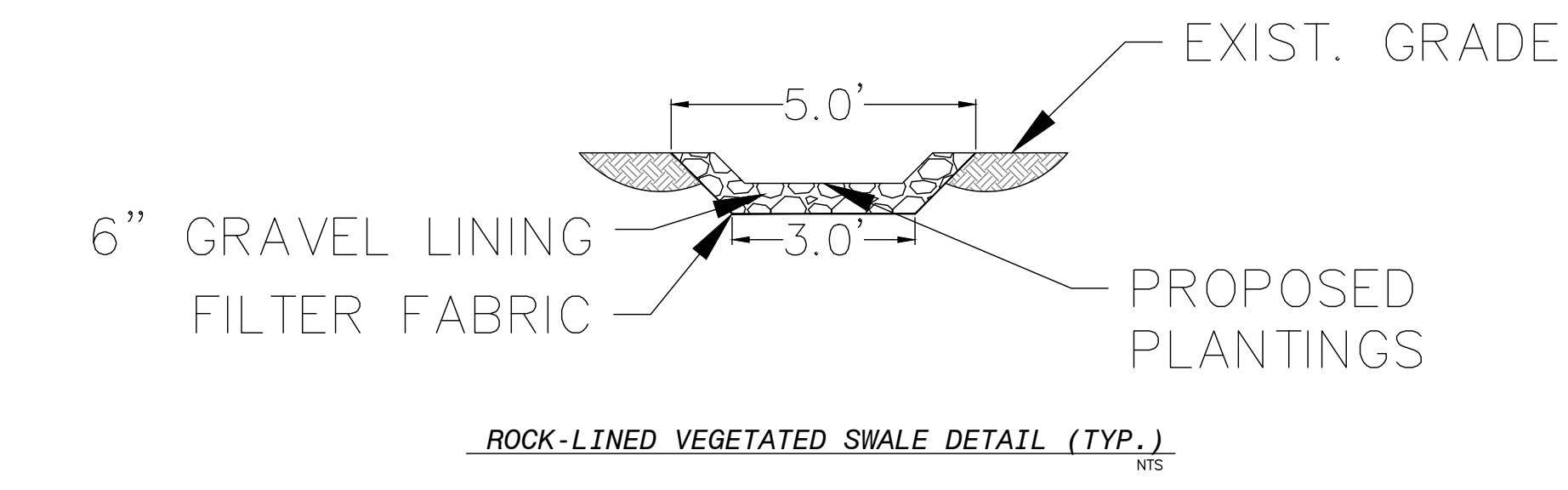

**ROCK-LINED VEGETATED SWALE DETAIL (TYP.)**  
NTS

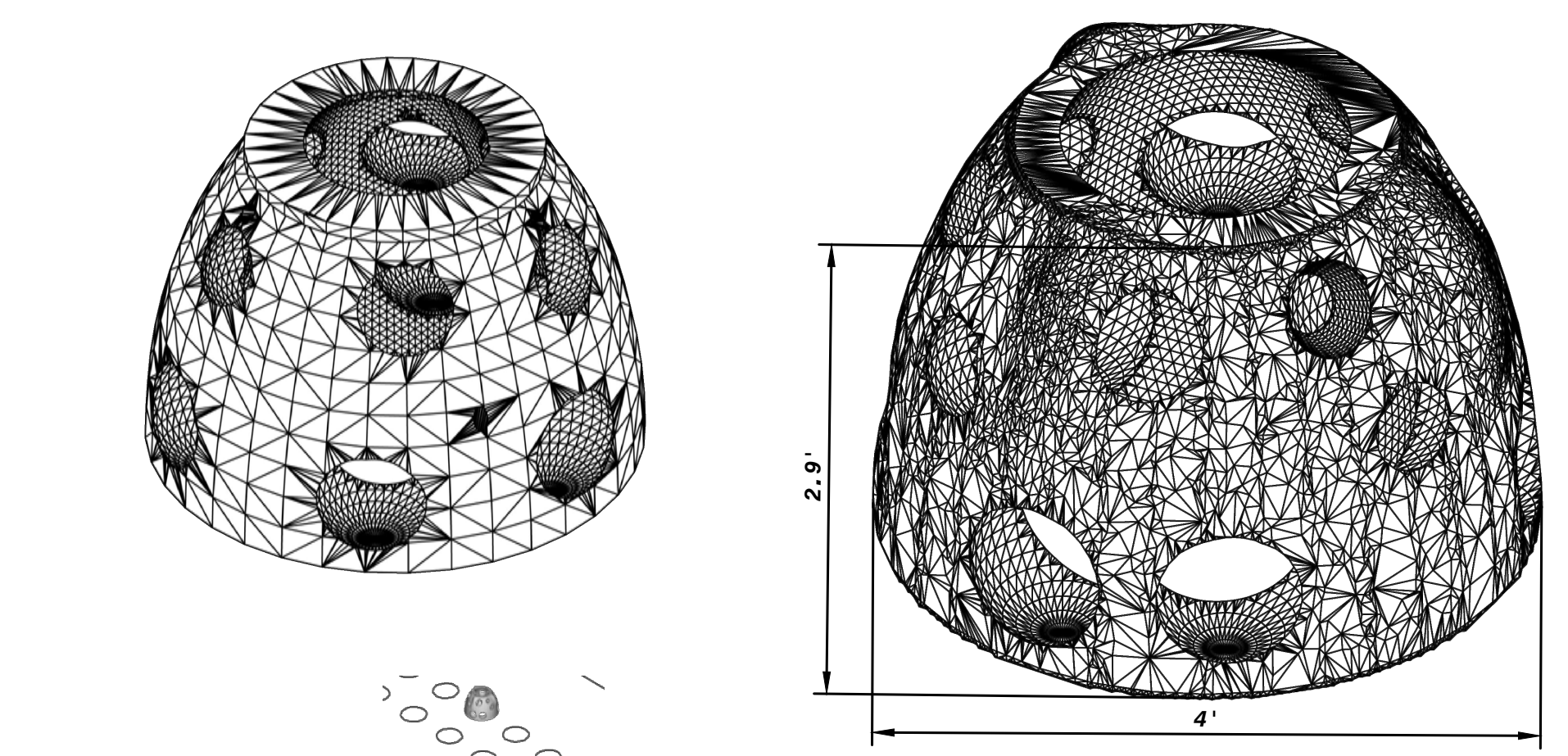

**REEFBALL PALLET BALL DETAIL (TYP.)**  
NTS

DESIGNED BY: Todd Barber	Bishop Point Work Flow Test		G	---
DATE: 4/8/2024	Jake Close, WSP CONFIDENTIAL TEST ONLY		F	---
SIZE: A4	Reef Ball Foundation (Living Shorelines)		E	---
SCALE: 100	WEIGHT (lb): Mixed	DRAWING NUMBER: PDF Test	D	---
DRAWING NUMBER: 1 of 1			C	---
DRAWING NUMBER: 1 of 1			B	---
DRAWING NUMBER: 1 of 1			A	---

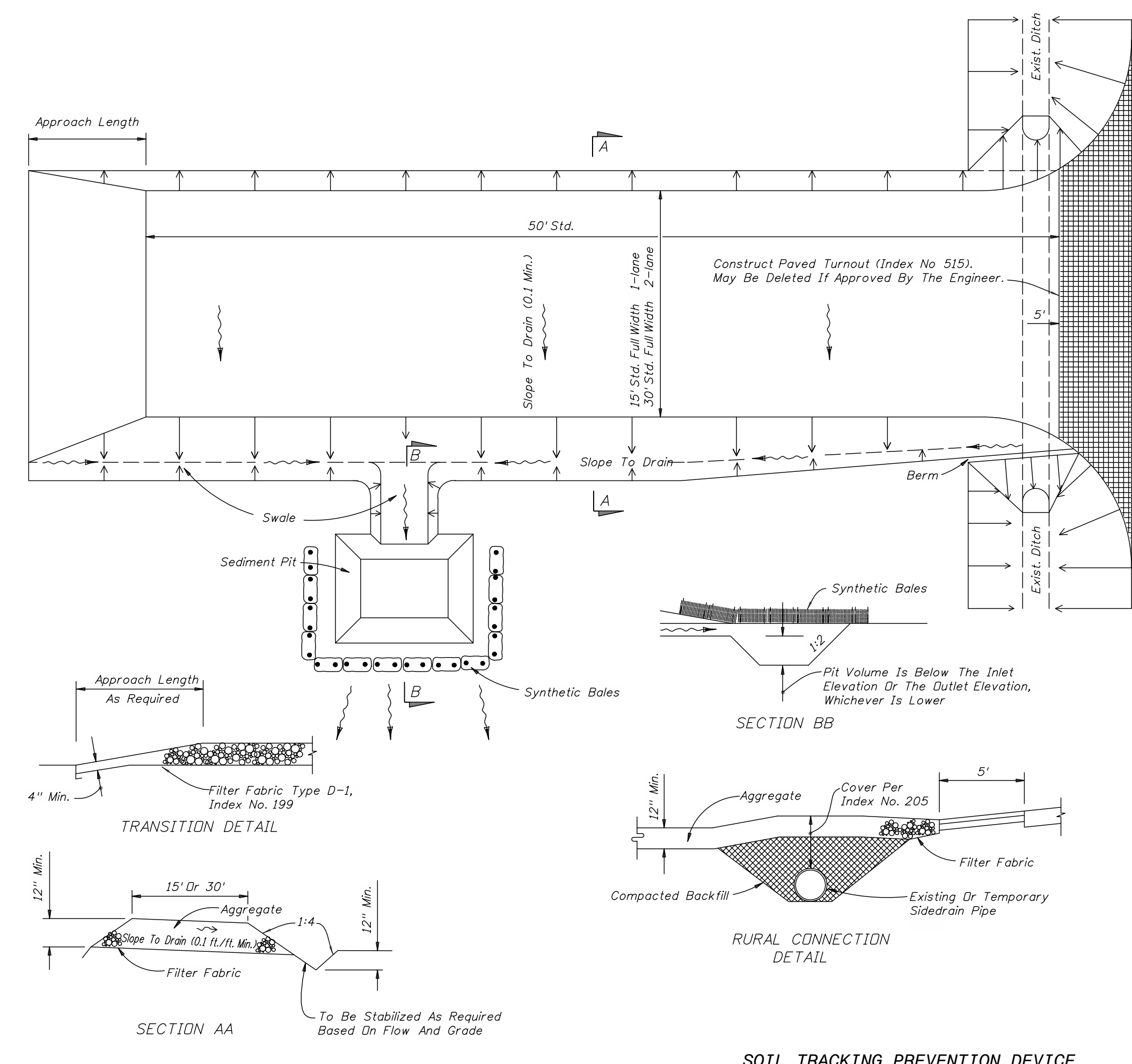

**SOIL TRACKING PREVENTION DEVICE**  
NTS

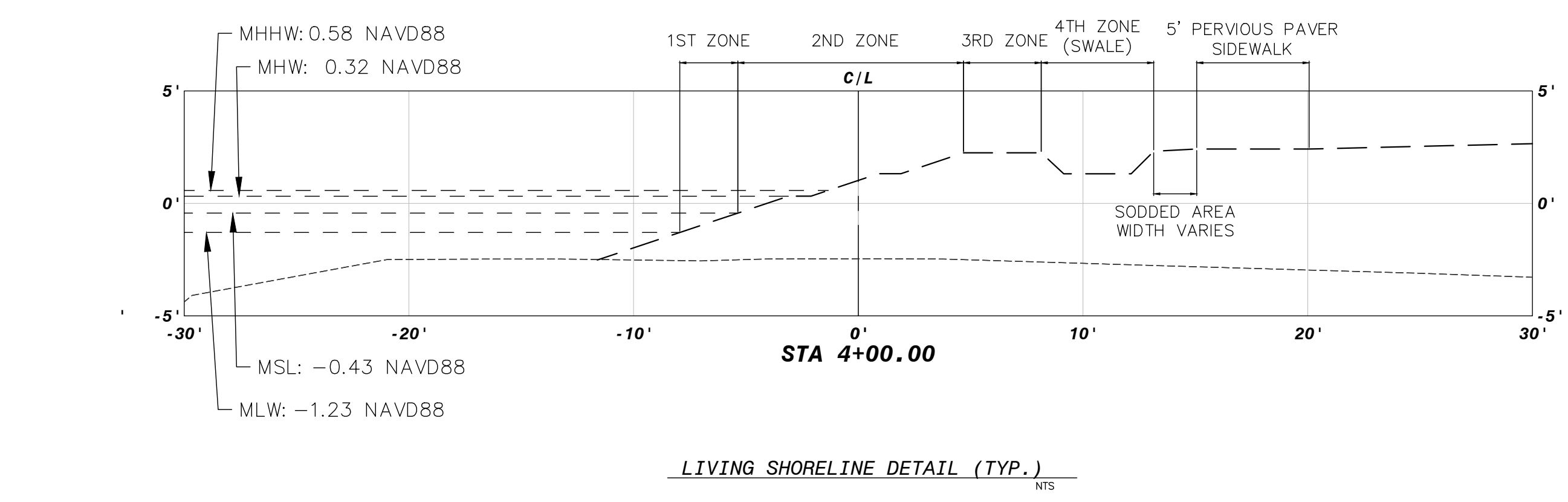

**LIVING SHORELINE DETAIL (TYP.)**  
NTS

- GENERAL NOTES**
1. A Soil Tracking Prevention Device (STPD) shall be constructed at locations designated by the engineer for points of egress from unstabilized areas of the project to public roads where off-site tracking of mud could occur. Traffic from unstabilized areas of the construction project shall be directed thru a STPD. Barriers, flagging, or other positive means shall be used as required to limit and direct vehicular egress across the STPD.
  2. The Contractor may propose an alternative technique to minimize off-site tracking of sediment. The alternative must be reviewed and approved by the Engineer prior to its use.
  3. All materials spilled, dropped, or tracked onto public roads (including the STPD aggregate and construction mud) shall be removed daily, or more frequently if so directed by the Engineer.
  4. Aggregates shall be as described in Section 901 excluding 901-2.3. Aggregates shall be F200 size #1. If this size is not available, the next available smaller size aggregate may be substituted with the approval of the Engineer. Sizes containing excessive small aggregate will track off the project and are unsuitable.
  5. The sediment pit should provide a retention volume of 3600 cubic feet/acre of surface area draining to the pit. When the STPD is isolated from other drainage areas, the following pit volumes will satisfy this requirement:  
15' x 50' = 100 ft.<sup>3</sup>    30' x 50' = 200 ft.<sup>3</sup>  
As an option to the sediment pit, the width of the swale bottom can be increased to obtain the volume. When the sediment pit or swale volume has been reduced to one half, it shall be cleaned. When a swale is used, synthetic bales or silt fence shall be placed along the entire length.
  6. The swale ditch draining the STPD shall have a 0.02% minimum and a 1.0% maximum grade along the STPD and to the sediment pit.
  7. Mitered end sections are not required when the side drain pipe satisfies the clear zone requirements.
  8. The STPD shall be maintained in a condition that will allow it to perform its function. To prevent off-site tracking, the STPD shall be rinsed (daily when in use) to move accumulated mud downward thru the stone. Additional stabilization of the vehicular route leading to the STPD may be required to limit the mud tracked.
  9. A STPD shall be paid for under the contract unit price for Soil Tracking Prevention Device, E.A. The unit price shall constitute full compensation for construction, maintenance, replacement of materials, removal, and restoration of the area utilized for the STPD including but not limited to excavation, grading, temporary pipe (including MES when required), filter fabric, aggregate, paved turnout (including asphalt and base construction), ditch stabilization, approach route stabilization, sediment removal and disposal, water, rinsing and cleaning of the STPD and cleaning of public roads, grassing and sod. Synthetic Bale or Bale Type Barrier shall be paid for under the contract unit price for Synthetic Bales, L.F. Silt fence shall be paid for under the contract unit price for Staked Silt Fence, L.F.
  10. The nominal size of a standard STPD is 15' x 50' unless otherwise shown in the plans. If the volume of entering and existing vehicles warrant, a 30' width STPD may be used if approved by the Engineer. When a double width (30') STPD is used, the pay quantity shall be 2 for each location.

**100% FOR PERMITTING & BIDDING**

5015 S. Florida Avenue, Suite 301  
Lakeland, FL 33813  
P+ 1 863-667-2345  
wsp.com

GREGORY CORNING  
FLORIDA PE LICENSE NO. 79293

**PROJECT:**  
BISHOP POINT LIVING  
SHORELINE DESIGN  
AND PERMITTING

BRADENTON, FLORIDA

**MANATEE COUNTY**  
1112 Manatee Avenue West  
Bradenton, FL 34205

**WSP PROJECT NO:**  
600865X4

REVISIONS			
NO.	DATE	BY	APPROVED

DESIGNED BY:	---
DRAWN BY:	---
CHECKED BY:	---
APPROVED BY:	---
DATE:	7/30/25

**SHEET TITLE:**

DESIGN DETAILS 1  
OF 2

<b>SHEET NUMBER:</b>	<b>REV. #</b>
C-501	-
SHEET 1 OF - SHEETS	



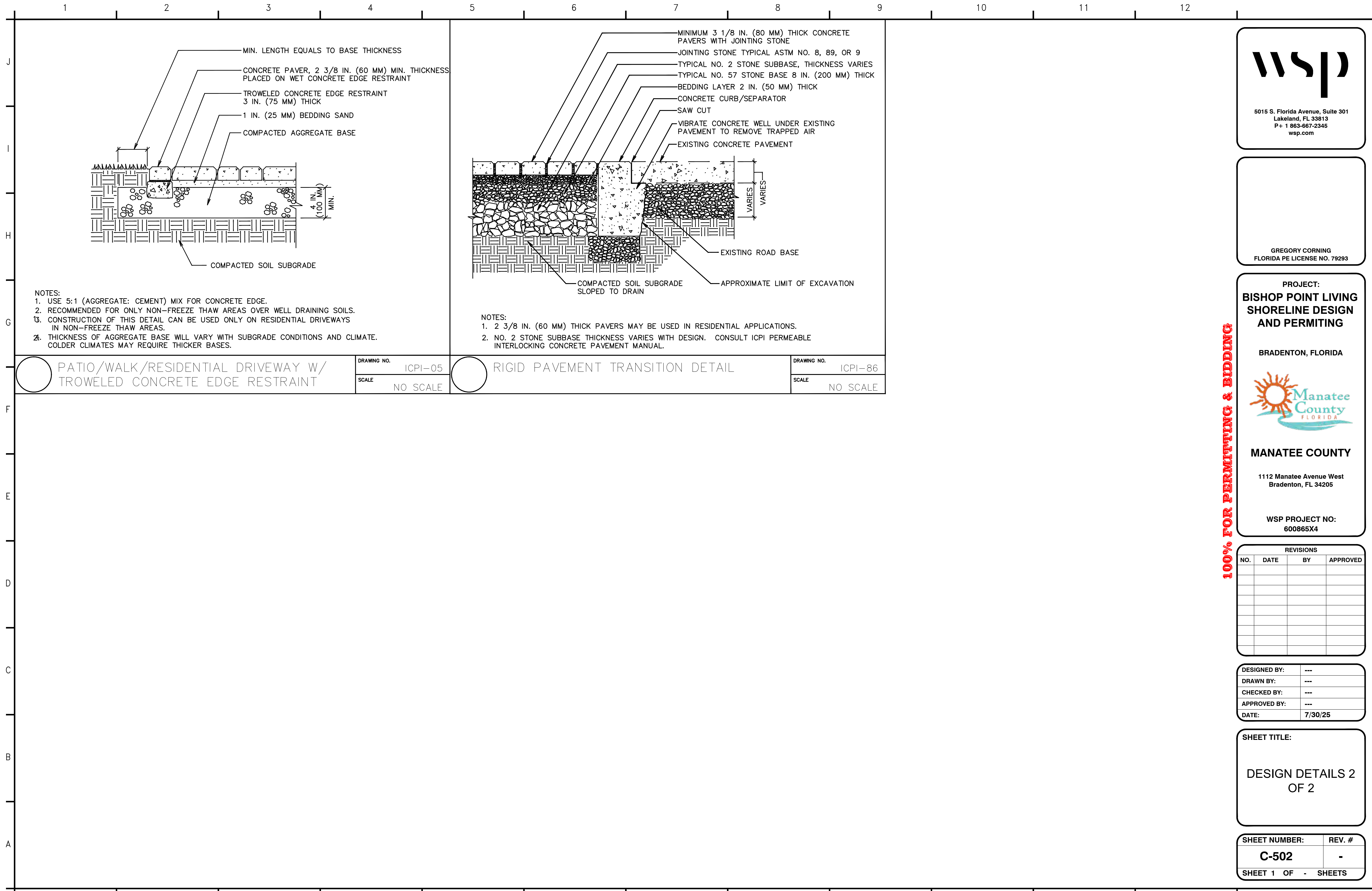

**wsp**

5015 S. Florida Avenue, Suite 301  
Lakeland, FL 33813  
P+ 1 863-667-2345  
wsp.com

GREGORY CORNING  
FLORIDA PE LICENSE NO. 79293

PROJECT:  
**BISHOP POINT LIVING  
SHORELINE DESIGN  
AND PERMITTING**

BRADENTON, FLORIDA

**MANATEE COUNTY**

1112 Manatee Avenue West  
Bradenton, FL 34205

WSP PROJECT NO:  
600865X4

**100% FOR PERMITTING & BIDDING**

REVISIONS			
NO.	DATE	BY	APPROVED

DESIGNED BY:	---
DRAWN BY:	---
CHECKED BY:	---
APPROVED BY:	---
DATE:	7/30/25

SHEET TITLE:  
**DESIGN DETAILS 2  
OF 2**

SHEET NUMBER:	REV. #
<b>C-502</b>	-
SHEET 1 OF - SHEETS	

PATIO/WALK/RESIDENTIAL DRIVEWAY W/  
TROWELED CONCRETE EDGE RESTRAINT

DRAWING NO. ICPI-05  
SCALE NO SCALE

RIGID PAVEMENT TRANSITION DETAIL

DRAWING NO. ICPI-86  
SCALE NO SCALE

## **Exhibit 5 – Technical Specifications for Bishop Point Living Shoreline**

### TABLE OF CONTENTS

DIVISION T1	GENERAL REQUIREMENTS
T01010	SUMMARY OF WORK
T01090	REFERENCE STANDARDS
T01150	MEASUREMENT AND PAYMENT
T01340	SHOP DRAWINGS, PROJECT DATA AND SAMPLES
T01600	MATERIAL AND EQUIPMENT
T01720	PROJECT RECORD DOCUMENTS
T01730	OPERATING AND MAINTENANCE DATA
DIVISION T2	SITE WORK
T02064	MODIFICATIONS TO EXISTING STRUCTURES
T02220	EXCAVATION, BACKFILL, FILL AND GRADING FOR STRUCTURES
T02221	TRENCHING, BEDDING, AND BACKFILL FOR PIPE
T02260	FINISH GRADING
T02276	TEMPORARY EROSION AND SEDIMENT CONTROL
T02480	LANDSCAPING (LIVING SHORELINE VEGETATION)
T02485	SEEDING AND SODDING
T02590	SHORELINE STABILIZATION AND RIPRAP
T02690	ARTIFICIAL REEF STRUCTURES
T02700	SITE RESTORATION AND CLEANUP

### **FINAL FEDERAL CONSISTENCY STATEMENT**

These Technical Specifications define quantities, materials, construction methods, and documentation requirements directly tied to the project Scope of Work and Independent Cost Estimate, ensuring enforceable scope control and cost reasonableness in accordance with 2 CFR 200.

## Exhibit 5 – Technical Specifications for Bishop Point Living Shoreline

### DIVISION T2 – FEDERAL CONSISTENCY STATEMENT

Division T2 specifications define enforceable construction methods, quantities, materials, and installation requirements directly tied to the project Scope of Work and Independent Cost Estimate, ensuring scope completeness and cost reasonableness in accordance with 2 CFR 200.

### DIVISION T1 GENERAL REQUIREMENTS

#### SECTION T01010 SUMMARY OF WORK

##### 1.01 PROJECT DESCRIPTION

The Bishop Point Living Shoreline Project consists of demolition of existing shoreline hardening features and construction of a living shoreline utilizing riprap, artificial reef structures, native vegetation, and upland stormwater features. The project is located at 2020 72<sup>nd</sup> Street NW, Bradenton, Florida, along the Manatee River.

##### 1.02 QUANTITIES AND WORK ELEMENTS

Work under this Contract includes, but is not limited to, the following approximate quantities:

- Removal of **426 linear feet** of existing concrete seawall
- Removal of **25 wooden posts (5 in. x 5 in.)**
- Removal of **21 concrete-filled PVC bollards**
- Removal of **24 linear feet of 24-inch reinforced concrete pipe**
- Installation of **approximately 700 cubic yards (3,789 square feet)** of riprap at a **4:1 slope**
- Placement of **69 manufactured reef balls** (43 along western shoreline; 26 in two staggered rows north/northwest)
- Grading of **approximately 3,492 square feet** of shoreline to a **3:1 slope**
- Installation of **388 square yards** of native shoreline vegetation
- Construction of **174 linear feet** of **5-foot-wide permeable paver walkway**
- Construction of **198 linear feet** of **4-foot-wide bioswale**
- Construction of **22 linear feet of 24-inch high-density polyethylene pipe**
- Construction of **Type C bubble up structure**

Quantities are approximate and intended for bid comparison. Final quantities shall be based on field conditions and approved plans.

## **Exhibit 5 – Technical Specifications for Bishop Point Living Shoreline**

### **1.03 CONSTRUCTION SEQUENCE**

1. Mobilization and installation of erosion controls
2. Demolition and removal of existing shoreline structures
3. Shoreline grading and riprap installation
4. Reef ball placement
5. Vegetation installation
6. Upland improvements (walkway and bioswale)
7. Final stabilization, cleanup, and documentation

## **SECTION T01090 REFERENCE STANDARDS**

### **1.01 APPLICABLE STANDARDS**

Construction and materials shall comply with the most current versions of the following:

- FDOT Standard Specifications for Road and Bridge Construction
- ASTM D4992, D698, D1557 (earthwork and materials testing)
- AASHTO M43 (riprap gradation)
- USACE Engineering Manual EM 385-1-1
- FDEP Environmental Resource Permit (ERP) conditions
- 2 CFR 200 – Uniform Guidance

Where discrepancies occur, the more stringent standard shall apply.

## **SECTION T01150 MEASUREMENT AND PAYMENT**

### **1.01 SCOPE**

- A. The scope of this section of the Contract Documents is to further define the items included in each Bid Item in the Bid Form section of the Contract Documents. Payments will be made based on the specified items included in the description in this section for each bid item.
- B. All contract prices included in the Bid Form section will be full compensation for all labor, supervision, materials, equipment, tools, incidentals, environmental protection measures, shop drawings, coordination, testing, quality control, and compliance necessary to complete the construction as shown on the Drawings and/or as specified in the Contract Documents to be performed under this Contract.

### **1.02 ESTIMATED QUANTITIES**

The quantities shown are approximate and are given only as a basis of calculation upon which the award of the Contract is to be made. The County does not assume any

## **Exhibit 5 – Technical Specifications for Bishop Point Living Shoreline**

responsibility for final quantities, nor shall the Contractor claim misunderstanding because of such estimate of quantities. Final payment will be made only for satisfactory completed quantity of each item.

### **1.03 WORK OUTSIDE AUTHORIZED LIMITS**

No payment will be made for work constructed outside the authorized limits of work.

### **1.04 MEASUREMENT STANDARDS**

Unless otherwise specified for the particular items involved, all measurements of distance shall be taken horizontally or vertically.

### **1.05 AREA MEASUREMENTS**

In the measurement of items to be paid for on the basis of area of finished work, the lengths and/or widths to be used in calculations shall be the final dimensions measured along the surface of the completed work within the neat lines shown or designated.

### **1.06 LUMP SUM ITEMS**

Where payment for items is shown to be paid for on a lump sum basis, no separate payment will be made for an item of work required to complete the lump sum items. Lump sum contracts shall be complete, tested and fully operable prior to request for final payment. Contractor may be required to provide a break-down of the lump sum totals.

### **1.07 UNIT PRICE ITEM**

Separate payment will be made for the items of work described herein and listed on the Bid Form. Any related work not specifically listed, but required for satisfactory completion of the work shall be considered to be included in the scope of the appropriate listed work items.

No separate payment will be made for the following items and the cost of such work shall be included in the applicable pay items of work. Final payments shall not be requested by the Contractor or made by the County until as-built (record) drawings have been submitted and approved by the County.

1. Mobilization and demobilization
2. Temporary access, staging, and marine logistics
3. Environmental protection, turbidity control, and erosion control
4. Permitting compliance and monitoring
5. Disposal of waste and excess materials
6. Shop drawings and submittals

## **Exhibit 5 – Technical Specifications for Bishop Point Living Shoreline**

7. Cleanup and site restoration
8. As-built documentation and record drawings
9. Testing and inspection support
10. Maintaining public access and site safety

Final payment shall not be made until Record Documents have been submitted and approved by the County.

### **BID ITEM NO. 1: MOBILIZATION/DEMobilIZATION (LUMP SUM)**

Measurement and payment for this Bid Item shall include full compensation for the required 100 percent (110%) Performance Bond, 100 percent Payment Bond, all required insurance for the project and the Contractor's mobilization and demobilization costs as shown in the Bid Form. Mobilization includes, but is not limited to: preparation and movement of personnel, equipment, supplies and incidentals such as safety and sanitary supplies/facilities.

Payment for Mobilization/Demobilization shall constitute full compensation for all costs associated with project startup and closeout, including but not limited to: mobilization of personnel, equipment, barges, cranes, marine access, staging areas, temporary facilities, safety equipment, bonds, insurance, and demobilization upon project completion.

Payment shall not exceed five percent (5%) of the total Contract Amount unless otherwise approved by the County.

### **BID ITEM NO. 2: MAINTENANCE OF TRAFFIC (LUMP SUM)**

Measurement for this Bid Item shall be on a Lump Sum basis for all Maintenance of Traffic (MOT) required for the duration of the Project.

Payment shall constitute full compensation for furnishing, installing, maintaining, relocating, and removing all traffic control devices, pedestrian control measures, signage, barricades, cones, flagging operations, and temporary access controls required to safely maintain public and contractor access to the site. This item shall include compliance with FDOT Index 600 series, local agency requirements, and any permit conditions associated with public access, roadway crossings, walkway closures, or marine access points. No separate payment shall be made for traffic control required to perform the Work.

### **BID ITEM NO. 3: SURVEY (LUMP SUM)**

Measurement for this Bid Item shall be on a Lump Sum basis.

Payment shall constitute full compensation for all survey services required to complete the Project in accordance with the Contract Documents, including but not limited to pre-

## **Exhibit 5 – Technical Specifications for Bishop Point Living Shoreline**

construction survey, construction layout and control, verification of installed improvements, preparation of partial and final surveys, and preparation of signed and sealed Record Drawings. The survey shall document the final locations, elevations, and alignments of all constructed features including riprap limits, reef balls, walkway, bioswale, HDPE piping, and the Type C Bubble-Up Structure. Record Drawings shall be submitted in both electronic (AutoCAD-compatible) and hard-copy format and must be accepted by the County prior to Final Payment.

### **BID ITEM NO. 4: TEMPORARY EROSION AND TURBIDITY CONTROL (LUMP SUM)**

Measurement shall be on a lump sum basis.

Payment shall be made at the Lump Sum price and shall constitute full compensation for furnishing, installing, maintaining, relocating, and removing all turbidity barriers, silt fencing, and other erosion control measures required by permits and Contract Documents

### **BID ITEM NO. 5: DEMOLITION AND REMOVAL OF EXISTING SHORELINE STRUCTURES (LUMP SUM)**

Measurement shall be on a Lump Sum basis for complete and accepted removal of existing shoreline structures within the authorized limits.

Quantities include, but not limited to:

- Concrete seawall: 426 LF
- 24-inch RCP removal: 24 LF
- Wooden posts (5 in. x 5 in.): 25 each
- Concrete-filled PVC bollards: 21 each

Payment shall be made at the Lump Sum price and shall include demolition, removal, loading, transportation, and lawful disposal of existing shoreline armoring, debris, and unsuitable materials, including all labor, equipment, and incidentals.

### **BID ITEM NO. 6: SHORELINE GRADING AND EARTHWORK (CUBIC YARD)**

Measurement shall be based on cubic yards of material excavated, placed, or regraded as shown on the Drawings and accepted.

Estimated Quantity:

- 100 CY

Payment shall be made at the contract unit price per cubic yard and shall include excavation, placement, compaction, shaping, and disposal of unsuitable material.

## **Exhibit 5 – Technical Specifications for Bishop Point Living Shoreline**

### **BID ITEM NO. 7: RIPRAP SHORELINE STABILIZATION (CUBIC YARD)**

Measurement shall be based on Cubic Yards (CY) of riprap placed, measured in-place and accepted.

Estimated Quantity:

- 701 CY (approximately 3,789 SF)

Payment shall include furnishing, transporting, and installing riprap; geotextile fabric; excavation; grading; keying into shoreline toe; placement to specified slopes; and all incidentals required for a complete shoreline stabilization system.

### **BID ITEM NO. 8: INLET STRUCTURE REPLACEMENT (LUMP SUM)**

24-INCH DIAMETER HDPE PIPE INSTALLATION (LINEAR FEET)

Measurement shall be based on Linear Feet (LF) of installed and accepted HDPE pipe.

Estimated Quantity:

- 22 LF

Payment shall include furnishing pipe, trenching, bedding, backfill, compaction, connections, testing, and surface restoration.

TYPE C BUBBLE-UP STRUCTURE (LUMP SUM)

Measurement shall be on a Lump Sum basis for one complete and operational structure.

Payment shall include furnishing and installing the structure, excavation, backfill, pipe connections, testing, and all incidentals required for a fully functional installation.

### **BID ITEM NO. 9: PERMEABLE PAVER WALKWAY (SQUARE FEET)**

Measurement shall be based on Linear Feet (LF) of completed walkway measured along centerline.

Estimated Quantity:

- 870 SF (174 LF, 5-foot width)

Payment shall include excavation, base preparation, permeable aggregate base, pavers, edge restraints, grading, and restoration necessary to provide a complete pedestrian walkway.

### **BID ITEM NO. 10: ARTIFICIAL REEF STRUCTURES (REEF BALLS) (EACH)**

Measurement shall be based on the number of reef ball units installed and accepted.



## **Exhibit 5 – Technical Specifications for Bishop Point Living Shoreline**

Estimated Quantity:

- 69 Each

Payment shall be made at the contract unit price per each and shall include fabrication, delivery, placement, anchoring, and stabilization of reef balls, including all materials, equipment, marine access, and incidentals.

### **BID ITEM NO. 11: LIVING SHORELINE VEGETATION (SQUARE YARD)**

Measurement shall be based on Square Yards (SY) of installed and accepted vegetation.

Estimated Quantity:

- 388 SY

Payment shall include furnishing native plant materials, installation at specified densities, anchoring, watering, establishment, and maintenance through construction completion.

### **BID ITEM NO. 12 BIOSWALE CONSTRUCTION (SQUARE FEET)**

Measurement shall be based on Linear Feet (LF) of bioswale constructed and accepted.

Estimated Quantity:

- 792 SF (198 LF, 4-foot width)

Payment shall include excavation, grading, stabilization, vegetation, and restoration necessary to convey and infiltrate upland runoff.

## **SECTION T01340 SHOP DRAWINGS, PROJECT DATA AND SAMPLES**

### **1.01 REQUIRED SUBMITTALS**

The Contractor shall submit:

- Reef ball manufacturer specifications and installation procedures
- Riprap source certification and gradation analysis
- Geotextile product data
- Permeable paver product data and base section details
- Plant species list, sizes, and nursery certifications

### **1.02 REVIEW**

Submittals shall be approved prior to delivery or installations.

## **Exhibit 5 – Technical Specifications for Bishop Point Living Shoreline**

### **SECTION T01600 MATERIAL AND EQUIPMENT**

#### **1.01 RIPRAP**

- Durable limestone meeting FDOT and AASHTO durability requirements
- Placed at 4:1 slope, keyed into shoreline toe
- Installed over approved geotextile fabric
- Thickness not less than 1.5 times maximum stone diameter

#### **1.02 REEF BALLS**

- Marine-grade concrete units approximately 2.9 ft x 4 ft
- Installed at 5-foot intervals along western shoreline
- Northern reef balls installed in two staggered rows
- Placement by crane or barge to avoid seabed disturbance

#### **1.03 VEGETATION**

- Native intertidal and upland species per approved plans
- Installed at design densities
- Plants shall be watered and maintained through construction

#### **1.04 PERMEABLE PAVER WALKWAY**

- Concrete permeable pavers designed for pedestrian traffic
- Installed over compacted, permeable aggregate base
- Finished surface shall match elevations shown to promote sheet flow

#### **1.05 BIOSWALE**

- Excavated to design depth and side slopes
- Stabilized with native vegetation
- Designed to convey and infiltrate upland runoff

#### **1.06 EQUIPMENT**

Marine equipment shall be suitable for shallow water operations and shall not damage adjacent habitats.

### **SECTION T01720 PROJECT RECORD DOCUMENTS**

#### **1.01 RECORD DOCUMENTATION**

The Contractor shall maintain daily records including:

- Installed locations and elevations
- Approved field modifications
- Material substitutions

## **Exhibit 5 – Technical Specifications for Bishop Point Living Shoreline**

### **1.02 SUBMITTAL**

Final as-built drawings shall be submitted in electronic and hard-copy formats prior to final payment.

## **SECTION T01730 OPERATING AND MAINTENANCE DATA**

### **1.01 CONTENT**

O & M documentation shall include:

- Maintenance procedures for permeable pavers
- Bioswale inspection and sediment removal guidance
- Vegetation establishment and replacement procedures

### **1.02 DELIVERY**

O & M manuals shall be submitted prior to project acceptance.

## **DIVISION T2 SITE WORK**

## **SECTION T02064 MODIFICATIONS TO EXISTING STRUCTURES**

### **1.01 DESCRIPTION**

This section includes demolition, removal, and disposal of existing shoreline structures and appurtenances to allow construction of the living shoreline system.

### **1.02 QUANTITIES**

- Concrete seawall: 426 LF
- Wooden posts (5 in. x 5 in.): 25 each
- Concrete-filled PVC bollards: 21 each
- Reinforced concrete pipe (24-inch diameter): 24 LF

### **1.03 DEMOLITION REQUIREMENTS**

- Saw-cut concrete seawall into manageable sections
- Remove structures without undermining adjacent uplands or waterways
- Prevent debris from entering waters of the State
- Dispose of all removed materials at licensed, off-site facilities

### **1.04 PROTECTION**

- Install turbidity curtains prior to demolition
- Maintain shoreline stability during removal operations

## **Exhibit 5 – Technical Specifications for Bishop Point Living Shoreline**

- Mangrove Protection per FDEP, 1996 Mangrove Trimming and Preservation Act (sections 403.9321-403.9333, F.S.)

### **SECTION T0220 EXCAVATION, BACKFILL, FILL AND GRADING FOR STRUCTURES**

#### **1.01 DESCRIPTION**

Includes excavating and backfill associated with construction of HDPE and bubble up structure.

#### **1.02 QUANTITIES**

- HDPE pipe construction trenching & backfill: 22 LF
- Structure construction trenching & backfill: Type C Bubble Up Structure

#### **1.03 CONSTRUCTION REQUIREMENTS**

- Excavate trenches to required depth and width
- Backfill using suitable material compacted to prevent settlement
- Restore surface grades to match adjacent conditions

### **SECTION T0221 TRENCHING, BEDDING, AND BACKFILL FOR PIPE**

#### **1.04 DESCRIPTION**

Includes trenching and backfill associated with removal and abandonment of existing reinforced concrete pipe and construction of the bioswale crossing beneath the walkway.

#### **1.05 QUANTITIES**

- RCP removal trenching: 24 LF
- Bioswale crossing beneath walkway: 198 LF, 4-foot wide

#### **1.06 CONSTRUCTION REQUIREMENTS**

- Excavate trenches to required depth and width
- Backfill using suitable material compacted to prevent settlement
- Restore surface grades to match adjacent conditions

### **SECTION T02260 FINISH GRADING**

#### **1.01 DESCRIPTION**

Finish grading of shoreline slopes and upland areas to achieve design elevations and slopes.

## **Exhibit 5 – Technical Specifications for Bishop Point Living Shoreline**

### **1.02 QUANTITIES**

- Shoreline grading: approximately 3,492 ft<sup>2</sup>
- Upland grading adjacent to walkway and bioswale as required

### **1.03 GRADING REQUIREMENTS**

- Shoreline slopes graded to 3:1 between riprap and reef ball features
- Riprap slopes constructed at 4:1
- Grades shall promote positive drainage toward the bioswale

## **SECTION T02276 TEMPORARY EROSION AND SEDIMENT CONTROL**

### **1.01 DESCRIPTION**

Temporary erosion and sediment control measures to protect water quality during construction.

### **1.02 REQUIREMENTS**

- Install turbidity curtains prior to in-water work
- Maintain controls throughout construction
- Remove controls after final stabilization and County approval

### **1.03 COMPLIANCE**

Measures shall comply with FDEP ERP permit conditions and FDOT standards.

## **SECTION T02480 LANDSCAPING (LIVING SHORELINE VEGETATION)**

### **1.01 DESCRIPTION**

Installation of native vegetation along shoreline and upland transition zones.

### **1.02 QUANTITIES**

- Living shoreline vegetation: 388 SY

### **1.03 MATERIALS**

- Native, nursery-grown plants appropriate for intertidal and upland zones, and in accordance with County approved planting plan
- Free of invasive species and pests

### **1.04 INSTALLATION**

- Install plants at densities shown in design plans
- Secure plants against tidal action

## **Exhibit 5 – Technical Specifications for Bishop Point Living Shoreline**

- Water and maintain plantings throughout construction

### **SECTION T02485 SEEDING AND SODDING**

#### **1.01 DESCRIPTION**

Stabilization of disturbed upland areas adjacent to construction.

#### **1.02 REQUIREMENTS**

- Provide sod or seed consistent with County standards
- Ensure stabilization prior to demobilization

### **SECTION T02590 SHORELINE STABILIZATION AND RIPRAP**

#### **1.01 DESCRIPTION**

Installation of riprap shoreline stabilization system.

#### **1.02 QUANTITIES**

- Riprap: approximately 700 CY (3,789 SF)

#### **1.03 MATERIALS**

- Limestone riprap meeting FDOT durability and gradation requirements
- Non-woven geotextile fabric beneath riprap

#### **1.04 INSTALLATION**

- Install riprap at 4:1 slope
- Key riprap into shoreline toe
- Place stone to achieve uniform thickness

### **SECTION T02690 ARTIFICIAL REEF STRUCTURES**

#### **1.01 DESCRIPTION**

Supply and installation of manufactured reef ball structures.

#### **1.02 QUANTITIES**

- Reef balls: 69 units
- Western shoreline: 43 units, 5-foot intervals
- North/Northwestern shoreline: 26 units, 5-foot intervals

#### **1.03 MATERIALS**

- Marine-grade concrete reef balls approximately 2.9 ft x 4 ft

## **Exhibit 5 – Technical Specifications for Bishop Point Living Shoreline**

- Approved manufacturer: Reef Innovations
- Approved model: Pallet Ball
- Must be sourced from the approved manufacturer or County-approved equal

### **1.04 INSTALLATION**

- Place units by crane or barge
- Avoid seabed disturbance
- Position per approved layout

## **SECTION T02700 SITE RESTORATION AND CLEANUP**

### **1.01 DESCRIPTION**

Final restoration of all disturbed areas.

### **1.02 REQUIREMENTS**

- Remove temporary facilities and controls
- Restore grades and vegetation
- Leave site in clean, stable position



# FLORIDA DEPARTMENT OF Environmental Protection

Ron DeSantis  
Governor

Alexis A. Lambert  
Secretary

Southwest District  
13051 North Telecom Parkway #101  
Temple Terrace, Florida 33637-0926

8/8/2025

Manatee County Public Works Natural Resources Department  
% Charlie Hundsicker  
1022 26th Avenue East  
Bradenton, Florida 34208  
[charlie.hundsicker@mymanatee.gov](mailto:charlie.hundsicker@mymanatee.gov)

Dear Charlie Hundsicker:

Enclosed is the Environmental Resource Permit, DEP Project No. 41-0454413-002-EI, issued pursuant to Part IV of Chapter 373, Florida Statutes, and Title 62, Florida Administrative Code.

Appeal rights for you and for any affected third party are described in the text of the permit along with conditions that must be met when authorized activities are undertaken.

You, as the applicant, are responsible for all aspects of permit compliance. You should therefore review this permit document carefully to ensure compliance with the general conditions and specific conditions contained herein.

Please be aware of permit General Condition number 4, which states, "At least 48 hours prior to beginning the authorized activities, the permittee shall submit to the Agency a fully executed Form 62-330.350(1), "Construction Commencement Notice"."

If you have any questions about this document, please contact me at [Olivia.oreilly@floridadep.gov](mailto:Olivia.oreilly@floridadep.gov) or (813) 470-5788. Thank you for your participation in the permit process and in managing the natural resources of the State of Florida.

Sincerely,

*Olivia O'Reilly*

Olivia O'Reilly  
Engineering Specialist I  
Permitting and Waste Cleanup Program

cc: Olivia O'Reilly, Southwest District, [Olivia.oreilly@floridadep.gov](mailto:Olivia.oreilly@floridadep.gov)  
Shannon Herbon, Southwest District, [shannon.herbon@floridadep.gov](mailto:shannon.herbon@floridadep.gov)  
ERP Permitting, Southwest District, [sw\\_erp@floridadep.gov](mailto:sw_erp@floridadep.gov)  
U.S. Army Corps of Engineers, [tampareg@usace.army.mil](mailto:tampareg@usace.army.mil)  
Sherri Swanson, Co-Applicant, [sherri.swanson@mymanatee.org](mailto:sherri.swanson@mymanatee.org)  
Gregory Corning, Consultant, [greg.corning@wsp.com](mailto:greg.corning@wsp.com)

Enclosure: Environmental Resource Permit with Attachments (41 pages)





# FLORIDA DEPARTMENT OF Environmental Protection

**Ron DeSantis**  
Governor

**Alexis A. Lambert**  
Secretary

Southwest District  
13051 North Telecom Parkway #101  
Temple Terrace, Florida 33637-0926

## **Permittee/Authorized Entity:**

Manatee County Public Works Natural Resources Department  
% Charlie Hundsicker  
1022 26th Avenue East  
Bradenton, Florida 34208

## **Bishop Point Living Shoreline**

### **Authorized Agent:**

WSP USA  
% Gregory Corning  
5411 SkyCenter Drive, Suite 659  
Tampa, Florida 33607

## **Individual Environmental Resource Permit**

### **State-owned Submerged Lands Authorization – Granted**

### **U.S. Army Corps of Engineers Authorization – Separate Corps Authorization Required**

Manatee County  
Permit No.: 41-0454413-002-EI

**Permit Issuance Date: 8/8/2025**  
**Permit Construction Phase Expiration Date: 8/7/2030**



# FLORIDA DEPARTMENT OF Environmental Protection

**Ron DeSantis**  
Governor

**Alexis A. Lambert**  
Secretary

Southwest District  
13051 North Telecom Parkway #101  
Temple Terrace, Florida 33637-0926

## **Consolidated Environmental Resource Permit and Sovereignty Submerged Lands Authorization**

**Permittee: Charlie Hundsicker**  
**Permit No: 41-0454413-002-EI**

### **PROJECT LOCATION**

The activities authorized by this permit are located at 2020 72nd Street Northwest Bradenton, Florida 34209, in Section 19, Township 34 South, Range 17 East, in Manatee County, at latitude 27.51961253 / longitude -82.63336874.

### **PROJECT DESCRIPTION**

The permittee is authorized to construct a living shoreline on an existing peninsula within Warners Bayou, a Class III, Florida Waterbody. These activities include the removal of an existing approximately 380-linear-foot seawall, approximately 25 5-inch by 5-inch posts, approximately 21 concrete filled PVC bollards, and approximately 24-linear-feet of reinforced concrete pipe. On the eastern side of the peninsula, approximately 1,026 square feet of riprap will be installed at a 4:1 slope, while the western side will feature 42 reef balls placed at 5-foot intervals. A 174-linear-foot, 5-foot-wide permeable paver walkway will be constructed in the uplands, extending to the Mean High-Water Line (MHWL), positioned between the riprap and reef ball areas. Adjacent to the walkway, a 198-linear-foot, 4-foot-wide bioswale will be constructed, beginning in the uplands, passing under the walkway at one point, and continuing to the MHWL. Approximately 388 square yards of native vegetation will be planted along the shoreline, adjacent to both the riprap and reef ball installations. Additionally, two staggered rows of reef balls, containing a total of 26 units, will be placed to the north of the living shoreline area. Authorized activities are depicted on the attached exhibits.

The permittee shall utilize a floating turbidity curtain and silt fence throughout the construction process. Soil tracking prevention devices will be used, and construction activities will be conducted in a manner to avoid harming existing vegetation and wildlife.

### **AUTHORIZATIONS**

#### **Bishop Point Living Shoreline**

#### Environmental Resource Permit

The Department has determined that the activity qualifies for an Environmental Resource Permit. Therefore, the Environmental Resource Permit is hereby granted, pursuant to Part IV of Chapter 373, Florida Statutes (F.S.), and Chapter 62-330, Florida Administrative Code (F.A.C.).

#### Sovereignty Submerged Lands Authorization

The activity is located on sovereignty submerged lands owned by the State of Florida. It therefore also requires authorization from the Board of Trustees of the Internal Improvement Trust Fund (Board of Trustees), pursuant to Article X, Section 11 of the Florida Constitution, and Section 253.77, F.S. As staff to the Board of Trustees of the Internal Improvement Trust Fund (Board of Trustees) under Sections 253.002, F.S., the Department has determined that the activity qualifies for and requires a Letter of Consent, as long as the work performed is located within the boundaries as described and is consistent with the terms and conditions herein.

During the term of this Letter of Consent you shall maintain satisfactory evidence of sufficient upland interest as required by paragraph 18-21.004(3)(b), Florida Administrative Code. If such interest is terminated or the Board of Trustees determines that such interest did not exist on the date of issuance of this Letter of Consent, this Letter of Consent may be terminated by the Board of Trustees at its sole option. If the Board of Trustees terminates this Letter of Consent, you agree not to assert a claim or defense against the Board of Trustees arising out of this Letter of Consent.

#### Federal Authorization

Your proposed activity as outlined on your application and attached drawings **does not qualify** for Federal authorization pursuant to the State Programmatic General Permit and a **SEPARATE permit** or authorization **shall be required** from the Corps. You must apply separately to the Corps using the Application for Department of the Army Permit (ENG 4345) or alternative as allowed by Corps regulations. More information on Corps permitting may be found online in the Jacksonville District Regulatory Division Sourcebook:

(<https://www.saj.usace.army.mil/Missions/Regulatory/Source-Book/>).

Authority for review - an agreement with the USACOE entitled "Coordination Agreement Between the U. S. Army Corps of Engineers (Jacksonville District) and the Florida Department of Environmental Protection (or Duly Authorized Designee), State Programmatic General Permit", Section 10 of the Rivers and Harbor Act of 1899, and Section 404 of the Clean Water Act.

#### Coastal Zone Management Consistent

Issuance of this authorization also constitutes a finding of consistency with Florida's Coastal Zone Management Program, as required by Section 307 of the Coastal Zone Management Act.

#### Water Quality Certification Granted

This permit also constitutes a *grant* of water quality certification under Section 401 of the Clean Water Act, 33 U.S.C. Section 1341. Pursuant to Rule 62-330.062, F.A.C. issuance of the individual or conceptual approval permit under this chapter shall constitute certification of compliance with water quality standards.

#### Other Authorizations

You are advised that authorizations or permits for this activity may be required by other federal, state, regional, or local entities including but not limited to local governments or municipalities.

This permit does not relieve you from the requirements to obtain all other required permits or authorizations.

The activity described may be conducted only in accordance with the terms, conditions and attachments contained in this document. Issuance and granting of the permit and authorizations herein do not infer, nor guarantee, nor imply that future permits, authorizations, or modifications will be granted by the Department.

## **PERMIT/SOVEREIGNTY SUBMERGED LANDS CONDITIONS**

The activities described must be conducted in accordance with:

- **The Specific Conditions**
- **The General Conditions**
- **The Special Consent Conditions**
- **The General Conditions for Sovereignty Submerged Lands Authorization**
- **The limits, conditions and locations of work shown in the attached drawings**
- **The term limits of this authorization**

You are advised to read and understand these conditions and drawings prior to beginning the authorized activities, and to ensure the work is conducted in conformance with all the terms, conditions, and drawings herein. If you are using a contractor, the contractor also should read and understand these conditions and drawings prior to beginning any activity. Failure to comply with these conditions, including any mitigation requirements, shall be grounds for the Department to revoke the permit and authorization and to take appropriate enforcement action. Operation of the facility is not authorized except when determined to be in conformance with all applicable rules and this permit and sovereignty submerged lands authorization, as described.

## **SPECIFIC CONDITIONS**

1. Submittals required herein (e.g., progress reports, as-built drawings, etc.) shall include the permittee's name and permit number 41-0454413-002-EI and shall be directed by e-mail to [SW\\_ERP\\_CAP@floridadep.gov](mailto:SW_ERP_CAP@floridadep.gov) with a subject line of "Compliance: permit number 41-0454413-002-EI", or by mail to:

Department of Environmental Protection  
Southwest District  
ATTN: ERP Compliance Assurance  
13051 North Telecom Parkway, Suite 101  
Temple Terrace, FL 33637-0926

2. The structure/work authorized by this permit shall not be placed/conducted on any property, other than that owned by the permittee, without the prior written approval of that property owner.

3. In the event the permittee files for bankruptcy prior to completion of work permitted and required by this permit, the permittee must notify the Department within 30 days of filing. The notification shall identify the bankruptcy court and case number and shall include a copy of the bankruptcy petition.

#### **SPECIFIC CONDITIONS – PRIOR TO ANY CONSTRUCTION**

4. Best management practices for erosion control shall be implemented prior to construction commencement and shall be maintained at all times during construction to prevent siltation and turbid discharges in excess of State water quality standards (>29 NTU's above background, pursuant to Rule 62-302, F.A.C. Methods may include, but are not limited to the use of staked hay bales, staked filter cloth, sodding, seeding, staged construction and the installation of turbidity screens around the immediate project site.

#### **SPECIFIC CONDITIONS – CONSTRUCTION ACTIVITIES**

5. Wetland areas or waterbodies that are outside the specific limits of construction authorized by this permit, must be protected from erosion, sedimentation, siltation, scouring, excess turbidity, and/or dewatering. There shall be no discharge in violation of the water quality standards in Chapter 62-302, F.A.C. Turbidity/erosion controls shall be installed prior to clearing, excavation or placement of fill material, shall be maintained until construction is completed, disturbed areas are stabilized, and turbidity levels have fallen to less than 29 NTU's above background ambient background. The turbidity and erosion control devices shall be removed within 14 days once these conditions are met.
6. Areas of exposed soils shall be isolated from wetlands or other surface waters to prevent erosion and deposition of these soils into wetlands or other surface waters during construction and operation of permitted activities.
7. The permittee shall be responsible for ensuring erosion control devices/procedures are inspected and maintained daily during all phases of construction authorized by this permit until areas disturbed during construction are sufficiently stabilized to prevent erosion, siltation, and turbid discharges.
8. A floating turbidity apron/curtain shall be installed around the waterward boundary of the construction area prior to construction and shall remain in place until construction is complete and turbidity levels within the work area have returned to background levels. The curtain will be kept outside of the seagrass beds as shown on Sheet C-104 to prevent the curtains from causing damage to the adjacent beds.
9. Floating turbidity curtains with weighted skirts shall be placed around the peninsula prior to the initiation of work authorized by this permit. The screens shall be maintained and remain in place for the duration of the construction to ensure turbidity levels outside the construction area do not violate state water quality standards (>29 NTU's over background). The permittee shall be responsible for inspecting and maintaining turbidity control devices so turbidity does not violate state water quality standards (>29 NTU's over background) outside of the turbidity screens.

10. The following measures shall be taken immediately by the permittee when turbidity levels within waters of the State surrounding the project site violate state water quality standards:
  - a. Immediately cease work contributing to the water quality violation.
  - b. Stabilize exposed soils contributing to the violation. Modify the work procedures responsible for the violation, install additional turbidity containment devices and repair non-functioning turbidity containment devices.
  - c. Notify the Department within 24 hours of the time the violation is first detected.
11. The riprap shall be constructed in accordance with the specifications per Sheet C-302 of the attached permit drawings and shall have a minimum waterward face slope of 3:1 (horizontal/vertical).
12. The riprap revetment shall be constructed in accordance with the distances from fixed landmarks as shown on Sheet C-103 the attached permit drawings.
13. "Riprap" shall consist of unconsolidated boulders, rocks, or clean concrete rubble with no exposed reinforcing rods or similar protrusions. The riprap shall be free of sediment, debris and toxins or otherwise deleterious substances, and shall have average dimensions of one to three feet in diameter.
14. The riprap revetment shall be fully constructed as shown on Sheet C-103 of the attached permit drawings prior to the placement of backfill material. Fill material used behind the riprap revetment shall be clean fill and free of vegetative matter, trash, garbage, toxic or hazardous waste or other unsuitable materials.
15. The permittee shall report any damage to wetlands/littoral zone area as a result of the riprap construction to the Department within 24 hours.
16. The seawall shall be fully constructed prior to the placement of any backfill material. Any fill material used behind the seawall shall be clean fill and free of vegetative matter, trash, garbage, toxic or hazardous waste or any other unsuitable materials.
17. Dredging within waters of the State for the purpose of providing backfill is specifically prohibited.
18. Watercraft associated with the construction of the permitted structure shall operate within waters of sufficient depth to preclude bottom scouring/prop dredging. There shall be a minimum 12-inch clearance between the deepest draft of the vessel (with the motor in the down position) and the top of submerged resources as measured at mean low water.
19. This permit does not authorize the installation of water, sewer, cable or utility lines within wetlands or waterbodies.

20. Unauthorized impacts to wetlands or shoreline as a result of the authorized construction shall be reported to the Department within 24 hours.
21. Storage or stockpiling of tools and materials (i.e., lumber, pilings, debris) within wetlands or other surface waters is prohibited.

### **SPECIFIC MANATEE CONDITIONS**

22. All personnel associated with the project shall be instructed about the presence of manatees and manatee speed zones, and the need to avoid collisions with, and injury to manatees. The permittee shall advise all construction personnel that there are civil and criminal penalties for harming, harassing, or killing manatees which are protected under the Marine Mammal Protection Act, the Endangered Species Act, and the Florida Manatee Sanctuary Act.
23. All vessels associated with the construction project shall operate at "Idle Speed/No Wake" at all times while in the immediate area and while in water where the draft of the vessel provides less than a four-foot clearance from the bottom. All vessels shall follow routes of deep water whenever possible.
24. Siltation or turbidity barriers shall be made of material in which manatees cannot become entangled, shall be properly secured, and shall be regularly monitored to avoid manatee entanglement or entrapment. Barriers shall not impede manatee movement.
25. All on-site project personnel are responsible for observing water-related activities for the presence of manatees. All in-water operations, including vessels, shall be shutdown if a manatee comes within 50 feet of the operation. Activities shall not resume until every manatee has moved beyond the 50-foot radius of the project operation, or until 30 minutes has elapsed wherein a manatee has not reappeared within 50 feet of the operation. Animals shall not be herded away or harassed into leaving.
26. Any collision with or injury to a manatee shall be reported immediately to the FWC Hotline at 1-888-404-FWCC. Collision and/or injury should also be reported to the U.S. Fish and Wildlife Service in Jacksonville (1-904-731-3336) for north Florida or Vero Beach (1-772-562-3909) for south Florida.
27. Temporary signs concerning manatees shall be posted prior to and during all in-water project activities. All signs are to be removed by the permittee upon completion of the project. Awareness signs that have already been approved for this use by the Florida Fish and Wildlife Conservation Commission (FWC) must be used. One sign measuring at least 3 ft. by 4 ft. which reads *Caution: Manatee Area* must be posted. A second sign measuring at least 8 1/2" by 11" explaining the requirements for "Idle Speed/No Wake" and the shutdown of in-water operations must be posted in a location prominently visible to all personnel engaged in water-related activities. Please see the Florida Fish and Wildlife Conservation Commission website for information on how to obtain appropriate signs: [http://www.myfwc.com/docs/WildlifeHabitats/Manatee\\_EducationalSign.pdf](http://www.myfwc.com/docs/WildlifeHabitats/Manatee_EducationalSign.pdf)

## **SPECIFIC CONDITIONS FOR LISTED SPECIES**

28. This permit does not authorize the permittee to cause any adverse impact to or “take” of state listed species and other regulated species of fish and wildlife. Compliance with state laws regulating the take of fish and wildlife is the responsibility of the owner or permittee associated with this project. Please refer to Chapter 68A-27 of the Florida Administrative Code for definitions of “take” and a list of fish and wildlife species. If listed species are observed onsite, Florida Fish and Wildlife Conservation Commission (FWC) staff are available to provide decision support information or assist in obtaining the appropriate FWC permits. Most marine endangered and threatened species are statutorily protected and a “take” permit cannot be issued. Requests for further information or review can be sent to [ConservationPlanningServices@MyFWC.com](mailto:ConservationPlanningServices@MyFWC.com).
29. If new information (e.g. listing of new species, new critical habitat, etc.) shows that the magnitude of impacts to federally listed species has the potential for adverse effects, the U.S. Fish and Wildlife Service (USFWS) will notify the Department. The Department will initiate coordination with the permittee and with the USFWS to determine what adverse impacts are likely and if additional minimization measures, reporting, or monitoring are required in order to be consistent with the Endangered Species Act, as deemed necessary by USFWS.
30. The Permittee shall report any injured, sick, or dead federally or state listed animal(s) discovered onsite to the Florida Fish and Wildlife Conservation Commission Wildlife Alert number at 888-404-FWCC (3922).

## **SPECIFIC CONDITIONS – CONSTRUCTION COMPLETION**

The permittee shall comply with the following conditions prior to the transfer to operation phase of the facility. All documentation required below shall be included with the permittee’s request to transfer the project to the operation phase [Form No. 62-330.310(2), F.A.C.].

31. Within 30 days after completion of construction of the permitted or authorized activity, and prior to transfer to operation, the permittee shall submit photographs of the completed structure. The photographs shall show the size and dimensions of all existing structures and activities within the permitted project area. Constructed deviations may require a permit modification and/or easement.
32. The permittee shall submit one set of signed, dated and sealed as-built drawings to the Department via email at [SW\\_ERP\\_CAP@dep.state.fl.us](mailto:SW_ERP_CAP@dep.state.fl.us) for review and approval within 30 days of completion of construction. (Please contact the Department for files that are too large to email for alternative means of submitting electronically.) The as-built drawings shall be based on the Department permitted construction drawings and any pertinent specific conditions, which should be revised to reflect changes made during construction. Both the original design and constructed elevations must be clearly shown. The plans must be clearly labeled as "as-built" or "record" drawings. Surveyed dimensions and elevations required shall be verified and signed, dated and sealed by a Florida registered professional. *As-builts shall be submitted to the Department regardless*



*of whether or not deviations are present. In addition, the permittee shall submit the “As-Built Certification and Request for Conversion to Operation Phase” form (Ch. 62-330.310(1), F.A.C.); as required in General Condition #6.*

The following information shall be verified on the as-built drawings from the engineering drawings signed and sealed by Gregory W. Corning, #79293, on 8/07/2025:

Plan View/ Cross Section Name	Drawing Number
Proposed Site Plan	C-103
Erosion and Sediment Controls Plan	C-104
Planting Plan	C-105
Cross Section 1 of 2	C-301
Cross Section 2 of 2	C-302

### **SPECIFIC CONDITIONS – OPERATION AND MAINTENANCE ACTIVITIES**

33. All ditches and swales from the point at which they receive runoff from the project area and through their entire downstream length shall be well maintained and stabilized to ensure that they are not subject to erosion.
34. All vegetative plantings will be monitored immediately after construction completion until the plantings are established, pruned and replanted as needed. After that point, periodic inspections will take place to track the condition of the area.

### **GENERAL CONDITIONS FOR INDIVIDUAL PERMITS**

The following general conditions are binding on all individual permits issued under this chapter, except where the conditions are not applicable to the authorized activity, or where the conditions must be modified to accommodate project-specific conditions.

1. All activities shall be implemented following the plans, specifications and performance criteria approved by this permit. Any deviations must be authorized in a permit modification in accordance with Rule 62-330.315, F.A.C. Any deviations that are not so authorized may subject the permittee to enforcement action and revocation of the permit under Chapter 373, F.S.
2. A complete copy of this permit shall be kept at the work site of the permitted activity during the construction phase, and shall be available for review at the work site upon request by the Agency staff. The permittee shall require the contractor to review the complete permit prior to beginning construction.
3. Activities shall be conducted in a manner that does not cause or contribute to violations of state water quality standards. Performance-based erosion and sediment control best management practices shall be installed immediately prior to, and be maintained during and after construction as needed, to prevent adverse impacts to the water resources and adjacent lands. Such practices shall be in accordance with the *State of Florida Erosion and Sediment*

*Control Designer and Reviewer Manual (Florida Department of Environmental Protection and Florida Department of Transportation June 2007), and the Florida Stormwater Erosion and Sedimentation Control Inspector's Manual (Florida Department of Environmental Protection, Nonpoint Source Management Section, Tallahassee, Florida, July 2008), which are both incorporated by reference in subparagraph 62-330.050(9)(b)5., F.A.C., unless a project-specific erosion and sediment control plan is approved or other water quality control measures are required as part of the permit.*

4. At least 48 hours prior to beginning the authorized activities, the permittee shall submit to the Agency a fully executed Form 62-330.350(1), "Construction Commencement Notice," (October 1, 2013), (<http://www.flrules.org/Gateway/reference.asp?No=Ref-02505>), incorporated by reference herein, indicating the expected start and completion dates. A copy of this form may be obtained from the Agency, as described in subsection 62-330.010(5), F.A.C., and shall be submitted electronically or by mail to the Agency. However, for activities involving more than one acre of construction that also require a NPDES stormwater construction general permit, submittal of the Notice of Intent to Use Generic Permit for Stormwater Discharge from Large and Small Construction Activities, DEP Form 62-621.300(4)(b), shall also serve as notice of commencement of construction under this chapter and, in such a case, submittal of Form 62-330.350(1) is not required.
5. Unless the permit is transferred under Rule 62-330.340, F.A.C., or transferred to an operating entity under Rule 62-330.310, F.A.C., the permittee is liable to comply with the plans, terms and conditions of the permit for the life of the project or activity.
6. Within 30 days after completing construction of the entire project, or any independent portion of the project, the permittee shall provide the following to the Agency, as applicable:
  - a. For an individual, private single-family residential dwelling unit, duplex, triplex, or quadruplex – "Construction Completion and Inspection Certification for Activities Associated With a Private Single-Family Dwelling Unit" [Form 62-330.310(3)]; or
  - b. For all other activities – "As-Built Certification and Request for Conversion to Operational Phase" [Form 62-330.310(1)].
  - c. If available, an Agency website that fulfills this certification requirement may be used in lieu of the form.
7. If the final operation and maintenance entity is a third party:
  - a. Prior to sales of any lot or unit served by the activity and within one year of permit issuance, or within 30 days of as-built certification, whichever comes first, the permittee shall submit, as applicable, a copy of the operation and maintenance documents (see sections 12.3 thru 12.3.3 of Volume I) as filed with the Department of State, Division of Corporations and a copy of any easement, plat, or deed restriction needed to operate or maintain the project, as recorded with the Clerk of the Court in the County in which the activity is located.

- b. Within 30 days of submittal of the as- built certification, the permittee shall submit “Request for Transfer of Environmental Resource Permit to the Perpetual Operation Entity” [Form 62-330.310(2)] to transfer the permit to the operation and maintenance entity, along with the documentation requested in the form. If available, an Agency website that fulfills this transfer requirement may be used in lieu of the form.
8. The permittee shall notify the Agency in writing of changes required by any other regulatory agency that require changes to the permitted activity, and any required modification of this permit must be obtained prior to implementing the changes.
9. This permit does not:
  - a. Convey to the permittee any property rights or privileges, or any other rights or privileges other than those specified herein or in Chapter 62-330, F.A.C.;
  - b. Convey to the permittee or create in the permittee any interest in real property;
  - c. Relieve the permittee from the need to obtain and comply with any other required federal, state, and local authorization, law, rule, or ordinance; or
  - d. Authorize any entrance upon or work on property that is not owned, held in easement, or controlled by the permittee.
10. Prior to conducting any activities on state-owned submerged lands or other lands of the state, title to which is vested in the Board of Trustees of the Internal Improvement Trust Fund, the permittee must receive all necessary approvals and authorizations under Chapters 253 and 258, F.S. Written authorization that requires formal execution by the Board of Trustees of the Internal Improvement Trust Fund shall not be considered received until it has been fully executed.
11. The permittee shall hold and save the Agency harmless from any and all damages, claims, or liabilities that may arise by reason of the construction, alteration, operation, maintenance, removal, abandonment or use of any project authorized by the permit.
12. The permittee shall notify the Agency in writing:
  - a. Immediately if any previously submitted information is discovered to be inaccurate; and
  - b. Within 30 days of any conveyance or division of ownership or control of the property or the system, other than conveyance via a long-term lease, and the new owner shall request transfer of the permit in accordance with Rule 62-330.340, F.A.C. This does not apply to the sale of lots or units in residential or commercial subdivisions or condominiums where the stormwater management system has been completed and converted to the operation phase.

13. Upon reasonable notice to the permittee, Agency staff with proper identification shall have permission to enter, inspect, sample and test the project or activities to ensure conformity with the plans and specifications authorized in the permit.
14. If prehistoric or historic artifacts, such as pottery or ceramics, projectile points, stone tools, dugout canoes, metal implements, historic building materials, or any other physical remains that could be associated with Native American, early European, or American settlement are encountered at any time within the project site area, the permitted project shall cease all activities involving subsurface disturbance in the vicinity of the discovery. The permittee or other designee shall contact the Florida Department of State, Division of Historical Resources, Compliance Review Section (DHR), at (850)245-6333, as well as the appropriate permitting agency office. Project activities shall not resume without verbal or written authorization from the Division of Historical Resources. If unmarked human remains are encountered, all work shall stop immediately and the proper authorities notified in accordance with section 872.05, F.S. For project activities subject to prior consultation with the DHR and as an alternative to the above requirements, the permittee may follow procedures for unanticipated discoveries as set forth within a cultural resources assessment survey determined complete and sufficient by DHR and included as a specific permit condition herein.
15. Any delineation of the extent of a wetland or other surface water submitted as part of the permit application, including plans or other supporting documentation, shall not be considered binding unless a specific condition of this permit or a formal determination under Rule 62-330.201, F.A.C., provides otherwise.
16. The permittee shall provide routine maintenance of all components of the stormwater management system to remove trapped sediments and debris. Removed materials shall be disposed of in a landfill or other uplands in a manner that does not require a permit under Chapter 62-330, F.A.C., or cause violations of state water quality standards.
17. This permit is issued based on the applicant's submitted information that reasonably demonstrates that adverse water resource-related impacts will not be caused by the completed permit activity. If any adverse impacts result, the Agency will require the permittee to eliminate the cause, obtain any necessary permit modification, and take any necessary corrective actions to resolve the adverse impacts.
18. A Recorded Notice of Environmental Resource Permit may be recorded in the county public records in accordance with subsection 62-330.090(7), F.A.C. Such notice is not an encumbrance upon the property.
19. In addition to those general conditions in subsection (1), above, the Agency shall impose any additional project-specific special conditions necessary to assure the permitted activities will not be harmful to the water resources, as set forth in rules 62-330.301 and 62-330.302, F.A.C., Volumes I and II, as applicable, and the rules incorporated by reference in this chapter.

## **SPECIAL CONSENT CONDITIONS**

1. The applicant agrees to indemnify, defend and hold harmless the Board of Trustees and the State of Florida from all claims, actions, lawsuits and demands in any form arising out of the authorization to use sovereignty submerged lands or the applicant's use and construction of structures on sovereignty submerged lands. This duty to indemnify and hold harmless will include any and all liabilities that are associated with the structure or activity including special assessments or taxes that are now or in the future assessed against the structure or activity during the period of the authorization.
2. Failure by the Board of Trustees to enforce any violation of a provision of the authorization or waiver by the Board of Trustees of any provision of the authorization will not invalidate the provision not enforced or waived, nor will the failure to enforce or a waiver prevent the Board of Trustees from enforcing the unenforced or waived provision in the event of a violation of that provision.
3. Applicant binds itself and its successors and assigns to abide by the provisions and conditions set forth in the authorization. If the applicant or its successors or assigns fails or refuses to comply with the provisions and conditions of the authorization, the authorization may be terminated by the Board of Trustees after written notice to the applicant or its successors or assigns. Upon receipt of such notice, the applicant or its successors or assigns will have thirty (30) days in which to correct the violations. Failure to correct the violations within this period will result in the automatic revocation of this authorization.
4. All costs incurred by the Board of Trustees in enforcing the terms and conditions of the authorization will be paid by the applicant. Any notice required by law will be made by certified mail at the address shown on page one of the authorization. The applicant will notify the Board of Trustees in writing of any change of address at least ten days before the change becomes effective.
5. This authorization does not allow any activity prohibited in a conservation easement or restrictive covenant that prohibits the activity.

#### **GENERAL CONDITIONS FOR SOVEREIGNTY SUBMERGED LANDS AUTHORIZATION**

Any use of sovereignty submerged lands is subject to the following general conditions are binding upon the applicant and are enforceable under Chapter 253, F.S.

1. Sovereignty submerged lands may be used only for the specified activity or use. Any unauthorized deviation from the specified activity or use and the conditions for undertaking that activity or use will constitute a violation. Violation of the authorization will result in suspension or revocation of the applicant's use of the sovereignty submerged lands unless cured to the satisfaction of the Board of Trustees.
2. Authorization under Rule 18-21.005, F.A.C., conveys no title to sovereignty submerged lands or water column, nor does it constitute recognition or acknowledgment of any other person's title to such land or water.

3. Authorizations under Rule 18-21.005, F.A.C., may be modified, suspended or revoked in accordance with its terms or the remedies provided in Sections 253.04, F.S. and Chapter 18-14, F.A.C.
4. Structures or activities will be constructed and used to avoid or minimize adverse impacts to resources.
5. Construction, use, or operation of the structure or activity will not adversely affect any species which is endangered, threatened or of special concern, as listed in Rules 68A-27.003, 68A-27.004, and 68A-27.005, F.A.C.
6. Structures or activities will not unreasonably interfere with riparian rights. When a court of competent jurisdiction determines that riparian rights have been unlawfully affected, the structure or activity will be modified in accordance with the court's decision.
7. Structures or activities will not create a navigational hazard.
8. Activities shall not interfere with the public easement for traditional uses of the sandy beaches provided in section 161.141, F.S.
9. Structures will be maintained in a functional condition and will be repaired or removed if they become dilapidated to such an extent that they are no longer functional. This shall not be construed to prohibit the repair or replacement subject to the provisions of rule 18-21.005, F.A.C., within one year, of a structure damaged in a discrete event such as a storm, flood, accident, or fire.
10. Structures or activities will be constructed, operated, and maintained solely for water dependent purposes, or for non-water dependent activities authorized under paragraph 18-21.004(1)(g), F.A.C., or any other applicable law.
11. The applicant agrees to indemnify, defend and hold harmless the Board of Trustees and the State of Florida from all claims, actions, lawsuits and demands in any form arising out of the authorization to use sovereignty submerged lands or the applicant's use and construction of structures on sovereignty submerged lands. This duty to indemnify and hold harmless will include any and all liabilities that are associated with the structure or activity including special assessments or taxes that are now or in the future assessed against the structure or activity during the period of the authorization.
12. Failure by the Board of Trustees to enforce any violation of a provision of the authorization or waiver by the Board of Trustees of any provision of the authorization will not invalidate the provision not enforced or waived, nor will the failure to enforce or a waiver prevent the Board of Trustees from enforcing the unenforced or waived provision in the event of a violation of that provision.
13. Applicant binds itself and its successors and assigns to abide by the provisions and conditions set forth in the authorization. If the applicant or its successors or assigns fails or

refuses to comply with the provisions and conditions of the authorization, the authorization may be terminated by the Board of Trustees after written notice to the applicant or its successors or assigns. Upon receipt of such notice, the applicant or its successors or assigns will have thirty (30) days in which to correct the violations. Failure to correct the violations within this period will result in the automatic revocation of this authorization.

14. All costs incurred by the Board of Trustees in enforcing the terms and conditions of the authorization will be paid by the applicant. Any notice required by law will be made by certified mail at the address shown on page one of the authorization. The applicant will notify the Board of Trustees in writing of any change of address at least ten days before the change becomes effective.
15. This authorization does not allow any activity prohibited in a conservation easement or restrictive covenant that prohibits the activity.

## **NOTICE OF RIGHTS**

This action is final and effective on the date filed with the Clerk of the Department unless a petition for an administrative hearing is timely filed under Sections 120.569 and 120.57, F.S., before the deadline for filing a petition. On the filing of a timely and sufficient petition, this action will not be final and effective until further order of the Department. Because the administrative hearing process is designed to formulate final agency action, the hearing process may result in a modification of the agency action or even denial of the application.

### Petition for Administrative Hearing

A person whose substantial interests are affected by the Department's action may petition for an administrative proceeding (hearing) under Sections 120.569 and 120.57, F.S. Pursuant to Rule 28-106.20 and 28-106.301, F.A.C., a petition for an administrative hearing must contain the following information:

- (a) The name and address of each agency affected and each agency's file or identification number, if known;
- (b) The name, address, any e-mail address, any facsimile number, and telephone number of the petitioner, if the petitioner is not represented by an attorney or a qualified representative; the name, address, and telephone number of the petitioner's representative, if any, which shall be the address for service purposes during the course of the proceeding; and an explanation of how the petitioner's substantial interests will be affected by the agency determination;
- (c) A statement of when and how the petitioner received notice of the agency decision;
- (d) A statement of all disputed issues of material fact. If there are none, the petition must so indicate;
- (e) A concise statement of the ultimate facts alleged, including the specific facts that the petitioner contends warrant reversal or modification of the agency's proposed action;
- (f) A statement of the specific rules or statutes that the petitioner contends require reversal or modification of the agency's proposed action, including an explanation of how the alleged facts relate to the specific rules or statutes; and

- (g) A statement of the relief sought by the petitioner, stating precisely the action that the petitioner wishes the agency to take with respect to the agency's proposed action.

The petition must be filed (received by the Clerk) in the Office of General Counsel of the Department at 3900 Commonwealth Boulevard, Mail Station 35, Tallahassee, Florida 32399-3000, or via electronic correspondence at [Agency\\_Clerk@dep.state.fl.us](mailto:Agency_Clerk@dep.state.fl.us). Also, a copy of the petition shall be mailed to the applicant at the address indicated above at the time of filing.

#### Time Period for Filing a Petition

In accordance with Rule 62-110.106(3), F.A.C., petitions for an administrative hearing by the applicant and persons entitled to written notice under Section 120.60(3), F.S., must be filed within 21 days of receipt of this written notice. Petitions filed by any persons other than the applicant, and other than those entitled to written notice under Section 120.60(3), F.S., must be filed within 21 days of publication of the notice or within 21 days of receipt of the written notice, whichever occurs first. You cannot justifiably rely on the finality of this decision unless notice of this decision and the right of substantially affected persons to challenge this decision has been duly published or otherwise provided to all persons substantially affected by the decision. While you are not required to publish notice of this action, you may elect to do so pursuant Rule 62-110.106(10)(a).

The failure to file a petition within the appropriate time period shall constitute a waiver of that person's right to request an administrative determination (hearing) under [Sections 120.569](#) and [120.57](#), F.S., or to intervene in this proceeding and participate as a party to it. Any subsequent intervention (in a proceeding initiated by another party) will be only at the discretion of the presiding officer upon the filing of a motion in compliance with Rule 28-106.205, F.A.C. If you do not publish notice of this action, this waiver will not apply to persons who have not received written notice of this action.

#### Extension of Time

Under Rule 62-110.106(4), F.A.C., a person whose substantial interests are affected by the Department's action may also request an extension of time to file a petition for an administrative hearing. The Department may, for good cause shown, grant the request for an extension of time. Requests for extension of time must be filed with the Office of General Counsel of the Department at 3900 Commonwealth Boulevard, Mail Station 35, Tallahassee, Florida 32399-3000, or via electronic correspondence at [Agency\\_Clerk@dep.state.fl.us](mailto:Agency_Clerk@dep.state.fl.us), before the deadline for filing a petition for an administrative hearing. A timely request for extension of time shall toll the running of the time period for filing a petition until the request is acted upon.

#### Mediation

Mediation is not available in this proceeding.

#### FLAWAC Review

The applicant, or any party within the meaning of Section 373.114(1)(a) or 373.4275, F.S., may also seek appellate review of this order before the Land and Water Adjudicatory Commission under Section 373.114(1) or 373.4275, F.S. Requests for review before the Land and Water Adjudicatory Commission must be filed with the Secretary of the Commission and served on the Department within 20 days from the date when this order is filed with the Clerk of the Department.



Judicial Review

Once this decision becomes final, any party to this action has the right to seek judicial review pursuant to Section 120.68, F.S., by filing a Notice of Appeal pursuant to Florida Rules of Appellate Procedure 9.110 and 9.190 with the Clerk of the Department in the Office of General Counsel (Station #35, 3900 Commonwealth Boulevard, Tallahassee, Florida 32399-3000) and by filing a copy of the Notice of Appeal accompanied by the applicable filing fees with the appropriate district court of appeal. The notice must be filed within 30 days from the date this action is filed with the Clerk of the Department.

Executed in Hillsborough County, Florida.

STATE OF FLORIDA DEPARTMENT  
OF ENVIRONMENTAL PROTECTION



---

Sarah McWilliams  
Environmental Manager  
Permitting and Waste Cleanup Programs  
Southwest District

**Attachments:**

Exhibit 1, Project Drawings and Design Specs., 12 pages  
Standard Manatee Construction Conditions 2011, 2 Pages  
Construction Commencement Notice/Form 62-330.350(1), 1 page  
As-Built Certification and Request for Conversion to Operation Phase/Form 62-330.310(1), 3 pages  
Operation and Maintenance Inspection Certification/Form 62-330.311(1), 2 pages  
Request for Transfer of Permit to the Perpetual Operation Entity/Form 62-330.310(2), 1 page  
Request to Transfer Permit/Form 62-330.340(1), 2 pages

**Copies furnished to:**

Olivia O'Reilly, Southwest District, [Olivia.oreilly@floridadep.gov](mailto:Olivia.oreilly@floridadep.gov)  
Shannon Herbon, Southwest District, [shannon.herbon@floridadep.gov](mailto:shannon.herbon@floridadep.gov)  
ERP Permitting, Southwest District, [sw\\_erp@floridadep.gov](mailto:sw_erp@floridadep.gov)  
U.S. Army Corps of Engineers, [tampareg@usace.army.mil](mailto:tampareg@usace.army.mil)  
Sherri Swanson, Co-Applicant, [sherri.swanson@mymanatee.org](mailto:sherri.swanson@mymanatee.org)  
Gregory Corning, Consultant, [greg.corning@wsp.com](mailto:greg.corning@wsp.com)

CERTIFICATE OF SERVICE

The undersigned hereby certifies that this permit including all copies, were mailed before the close of business on **August 8, 2025**, to the above listed persons.

FILING AND ACKNOWLEDGMENT

FILED, on this date, under 120.52(7) of the  
Florida Statutes, with the designated Department Clerk,

receipt of which is hereby acknowledged.

  
Clerk

August 8, 2025  
Date



DEPARTMENT OF THE ARMY  
U.S. ARMY CORPS OF ENGINEERS, JACKSONVILLE DISTRICT  
701 SAN MARCO BOULEVARD  
JACKSONVILLE, FLORIDA 32207

August 19, 2025

Regulatory Division  
West Permits Branch  
Tampa Section  
SAJ-2024-00265 (NWP-RSS)

Charlie Hunsicker  
Manatee County Public Works Natural Resources Dept.  
1022 26th Avenue East  
Bradenton, FL 34208  
Sent via email: [Charlie.hunsicker@mymanatee.org](mailto:Charlie.hunsicker@mymanatee.org)

Dear Charlie Hunsicker:

The U.S. Army Corps of Engineers (Corps) has completed the review of your application for a Department of the Army permit received on October 16, 2024. Your application was assigned file number SAJ-2024-00265. A review of the information and drawings provided indicates that the proposed work would result in removal of a 375-linear foot (LF) seawall along the Manatee River and replacing it with a living shoreline. The project also involves removal of twenty-one (21) concrete pilings and deployment of reef balls, measuring 2.9-ft by 4-ft (11.6 square feet (SF) each), to facilitate recruitment of aquatic organisms. Approximately 3,789 SF of riprap (701 cubic yards (CY)) would be placed along the shoreline in place of the seawall. Forty-three (43) reef balls would be utilized as a breakwater system in the footprint of the removed concrete pilings. An additional twenty-six (26) reef balls would be staggered to the northern and northwestern limits of the project footprint, directly in Manatee River. A living shoreline, composed of native vegetation, would be deployed along channel between the riprap and the reef balls. Native plantings would be planted on a 3:1 graded slope and encompass an area of approximately 3,263 SF. The activities subject to this permit are authorized pursuant to authorities under Section 10 of the Rivers and Harbors Act of 1899 (33 U.S.C. § 403) and Section 404 of the Clean Water Act (33 U.S.C. § 1344). The project is located in the Manatee River at Bishop Point Park, 2020 72nd St NW, in Section 19, Township 34 South, Range 17 East, Bradenton, Manatee County, Florida.

Your project, as depicted on the enclosed drawings (**Attachment 1**), is authorized by Nationwide Permit (NWP) 13 (Bank Stabilization) and 54 (Living Shorelines). **This verification is valid until March 14, 2026.** In order for this NWP authorization to be valid, you must ensure that the work is performed in accordance with the Nationwide Permit General Conditions, the Jacksonville District Regional Conditions, and the General and Project-Specific Special Conditions listed below. Furthermore, if you commence or are under contract to commence this activity before the date that the relevant NWP is modified or revoked, you will have 12 months from the date of the modification or revocation of the NWP to complete the activity under the present terms and conditions of this NWP.

You can access the U.S. Army Corps of Engineers' (Corps) Jacksonville District's Regulatory Source Book webpage for links to view NWP information at: <https://www.saj.usace.army.mil/Missions/Regulatory/Source-Book/>. Please be aware this Internet address is case sensitive and should be entered as it appears above. Once there, you will need to select "Nationwide Permits." Among other things, this part of the Source Book contains links to the federal register containing the text of the pertinent NWP authorization and the associated NWP general conditions, as well as separate links to the regional conditions applicable to the pertinent NWP verification.

**You must comply with all of the special and general conditions for NWP-13 and NWP-54, including any project-specific conditions included in this letter and all conditions incorporated by reference as described above.**

**General Conditions:**

1. The time limit for completing the work authorized ends on **March 14, 2026**.
2. You must maintain the activity authorized by this permit in good condition and in conformance with the terms and conditions of this permit. You are not relieved of this requirement if you abandon the permitted activity, although you may make a good faith transfer to a third party in compliance with General Condition 4 below. Should you wish to cease to maintain the authorized activity, or should you desire to abandon it without a good faith transfer, you must obtain a modification of this permit from this office, which may require restoration of the area.
3. If you discover any previously unknown historic or archeological remains while accomplishing the activity authorized by this permit, you must immediately notify this office of what you have found. We will initiate the Federal and state coordination required to determine if the remains warrant a recovery effort of if the site is eligible for listing in the National Register of Historic Places.
4. If you sell the property associated with this permit you must obtain the signature of the new owner on the attached transfer form (**Attachment 2**) and forward a copy to this office to validate the transfer of this authorization.
5. If a conditioned water quality certification has been issued for your project, you must comply with the conditions specified in the certification as special conditions to this permit. For your convenience, a copy of the certification is attached if it contains such conditions (**Attachment 3**).
6. You must allow a representative from this office to inspect the authorized activity at any time deemed necessary to ensure that it is being or has been accomplished in accordance with the terms and conditions of your permit.

**Project Specific Special Conditions:**

The following project specific special conditions are included with this verification:

1. **Reporting Address:** The Permittee shall submit all reports, notifications, documentation, and correspondence required by the general and special conditions of this permit to either (not both) of the following addresses:
  - a. For electronic mail (preferred): SAJ-RD-Enforcement@usace.army.mil (not to exceed 15 MB).
  - b. For standard mail: U.S. Army Corps of Engineers, Regulatory Division, Enforcement Section, P.O. Box 4970, Jacksonville, FL 32232-0019.The Permittee shall reference this permit number, SAJ-2024-00265 (NWP-RSS), on all submittals.
2. **Posting of Permit:** The Permittee shall have available and maintain for review a copy of this permit and approved plans at the construction site.
3. **Self-Certification:** Within 60 days of completion of the work authorized by this permit, the Permittee shall complete the ENG Form 6285, "Certification of Compliance with Department of Army Permit" (located at [https://www.publications.usace.army.mil/Portals/76/Eng\\_Form\\_6285\\_2024%20DEC%20FINAL.pdf](https://www.publications.usace.army.mil/Portals/76/Eng_Form_6285_2024%20DEC%20FINAL.pdf)) and submit it to the Corps.
4. **Cultural Resources/Historic Properties:**
  - a. No structure or work shall adversely affect, impact, or disturb properties listed in the National Register of Historic Places (NRHP), or those eligible for inclusion in the NRHP.
  - b. If, during permitted activities, items that may have historic or archaeological origin are observed the Permittee shall immediately cease all activities adjacent to the discovery that may result in the destruction of these resources and shall prevent his/her employees from further removing, or otherwise damaging, such resources. The applicant shall notify both the Florida Department of State, Division of Historical Resources, Compliance Review Section at (850)-245-6333 and the Corps, of the observations within the same business day (8 hours). Examples of submerged historical, archaeological or cultural resources include shipwrecks, shipwreck debris fields (such as steam engine parts, or wood planks and beams), anchors, ballast rock, concreted iron objects, concentrations of coal, prehistoric watercraft (such as log "dugouts"), and other evidence of human activity. The materials may be deeply buried in sediment, resting in shallow sediments or above them, or protruding into water. The Corps shall coordinate with the Florida State Historic Preservation Officer (SHPO) to assess the significance of the discovery and devise appropriate actions. Project activities shall not resume without verbal and/or written authorization from the Corps.

- c. Additional cultural resources assessments may be required of the permit area in the case of unanticipated discoveries as referenced in accordance with the above Special Condition and, if deemed necessary by the SHPO or Corps, in accordance with 36 CFR 800 or 33 CFR 325, Appendix C (5). Based on the circumstances of the discovery, equity to all parties, and considerations of the public interest, the Corps may modify, suspend, or revoke the permit in accordance with 33 CFR Part 325.7. Such activity shall not resume on non-federal lands without written authorization from the SHPO for finds under his or her jurisdiction, and from the Corps.
  - d. In the unlikely event that unmarked human remains are identified on nonfederal lands; they will be treated in accordance with Section 872.05 Florida Statutes. All work and ground disturbing activities within a 100-meter diameter of the unmarked human remains shall immediately cease and the Permittee shall immediately notify the medical examiner, Corps, and State Archaeologist within the same business day (8-hours). The Corps shall then notify the appropriate SHPO. Based on the circumstances of the discovery, equity to all parties, and considerations of the public interest, the Corps may modify, suspend, or revoke the permit in accordance with 33 CFR Part 325.7. Such activity shall not resume without written authorization from the SHPO and from the Corps.
- 5. Assurance of Navigation and Maintenance:** The Permittee understands and agrees that, if future operations by the United States (U.S.) require the removal, relocation, or other alteration, of the structures or work herein authorized, or if in the opinion of the Secretary of the Army or his authorized representative, said structure or work shall cause unreasonable obstruction to the free navigation of the navigable waters, the Permittee will be required, upon due notice from the U.S. Army Corps of Engineers, to remove, relocate, or alter the structural work or obstructions caused thereby, without expense to the United States. No claim shall be made against the U.S. on account of any such removal or alteration.
- 6. Jacksonville District Programmatic Biological Opinion (JAXBO):** Structures and activities authorized under this permit will be constructed and operated in accordance with all applicable project design criteria's (PDCs) contained in the JAXBO, based on the permitted activity. Johnson's seagrass and its critical habitat were delisted from the Endangered Species Act on May 16, 2022. Therefore, JAXBO PDCs required to minimize adverse effects to Johnson's seagrass and its critical habitat are no longer applicable to any project. Failure to comply with applicable PDCs will constitute noncompliance with this permit. In addition, failure to comply with the applicable PDCs, where a take of listed species occurs, would constitute an unauthorized take. NMFS is the appropriate authority to determine compliance with the Endangered Species Act. The most current version of JAXBO can be accessed at the Jacksonville District Regulatory Division website in the Endangered Species section of the Sourcebook located at: <http://www.saj.usace.army.mil/Missions/Regulatory/SourceBook.aspx>

JAXBO may be subject to revision at any time. The most recent version of the JAXBO must be utilized during the design and construction of the permitted work.

- 7. Manatee Conditions:** The Permittee shall comply with the “Standard Manatee Conditions for In-Water Work – 2011”. The most recent version of the Manatee Conditions must be utilized (**Attachment 4**).
- 8. Proposed Species/Critical Habitat:** At this time, this project does not fall within the range for any known candidate or proposed species to be federally listed and/or proposed critical habitat to be designated under the Endangered Species Act. If any species or critical habitat should become federally listed within the range of the permitted action, the Permittee is required to stop work and ask the Corps to re-evaluate effects on the species or designated critical habitat, and if needed, complete Section 7 consultation with the United States Fish and Wildlife Service or National Marine Fisheries Service to address potential impacts to the species and/or designated critical habitat.
- 9. Turbidity Barriers:** Prior to the initiation of any of the work authorized by this permit, the Permittee shall install floating turbidity barriers with weighted skirts that extend within define distance desired or use 1 foot of the bottom around all work areas that are in, or adjacent to, surface waters. The turbidity barriers shall remain in place and be maintained daily until the authorized work has been completed and turbidity within the construction area has returned to ambient levels. Turbidity barriers shall be removed upon stabilization of the work area.
- 10. Erosion Control:** Prior to initiation of any work authorized by this permit, the Permittee shall install erosion control measures along the perimeter of all work areas to prevent the displacement of fill material outside the work area into waters of the U.S. Erosion control measures shall remain in place and be maintained until all authorized work is completed and the work areas are stabilized.
- 11. Fill Material:** The Permittee shall use only clean fill material for this project. The fill material shall be free from items such as trash, debris, automotive parts, asphalt, construction materials, concrete block with exposed reinforcement bars, and soils contaminated with any toxic substance in toxic amounts, in accordance with Section 307 of the Clean Water Act.
- 12. Work Vessel Anchoring:** This permit does not authorize construction work vessels anchoring or spudding down in areas where mangroves are present.

This letter of authorization does not include conditions that would prevent the ‘take’ of a state-listed fish or wildlife species. These species are protected under sec. 379.411, Florida Statutes, and listed under Rule 68A-27, Florida Administrative Code. With regard to fish and wildlife species designated as species of special concern or threatened by the State of Florida, you are responsible for coordinating directly with the



Florida Fish and Wildlife Conservation Commission (FWC). You can visit the FWC license and permitting webpage (<http://www.myfwc.com/license/wildlife/>) for more information, including a list of those fish and wildlife species designated as species of special concern or threatened. The Florida Natural Areas Inventory (<http://www.fnai.org/>) also maintains updated lists, by county, of documented occurrences of those species.

This letter of authorization does not give absolute Federal authority to perform the work as specified on your application. The proposed work may be subject to local building restrictions mandated by the National Flood Insurance Program. You should contact your local office that issues building permits to determine if your site is located in a flood-prone area, and if you must comply with the local building requirements mandated by the National Flood Insurance Program.

**This letter of authorization does not preclude the necessity to obtain any other Federal, State, or local permits which may be required.**

Thank you for your cooperation with our permit program. The Corps' Jacksonville District Regulatory Division is committed to improving service to our customers. We strive to perform our duty in a friendly and timely manner while working to preserve our environment. We invite you to complete our automated Customer Service Survey at <https://regulatory.ops.usace.army.mil/customer-service-survey/>. Please be aware this Internet address is case sensitive and you will need to enter it exactly as it appears above. Your input is appreciated – favorable or otherwise.

Should you have any questions related to this verification letter or have issues accessing the documents referenced in this letter please contact Rachel S. Somerville at the letterhead address above, via telephone at 904-232-1444, or via e-mail at [Rachel.S.Somerville@usace.army.mil](mailto:Rachel.S.Somerville@usace.army.mil).

Sincerely,

Rachel S. Somerville  
Biologist | Project Manager  
Tampa Permits Section

Attachments (4):

ATTACHMENT 1: Permit drawings (12 pages)  
ATTACHMENT 2: Transfer Request (1 page)  
ATTACHMENT 3: Water Quality Certification (20 pages)  
ATTACHMENT 4: Manatee Conditions (2 pages)

Cc (via email):

Greg Corning – WSP – email: [greg.corning@wsp.com](mailto:greg.corning@wsp.com)

# BISHOP POINT LIVING SHORELINE

MANATEE COUNTY, FLORIDA

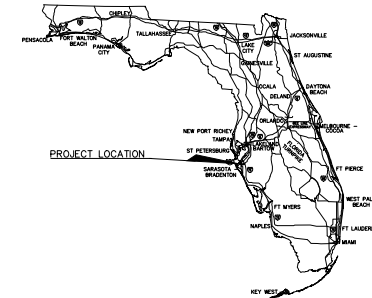

**wsp**

5015 S. Florida Avenue, Suite 301  
Lakeland, FL 33813  
P+ 1 888-887-2345  
wsp.com

GREGORY CORNING  
FLORIDA PE LICENSE NO. ....

PROJECT:  
**BISHOP POINT LIVING SHORELINE DESIGN AND PERMITTING**

BRADENTON, FLORIDA

**MANATEE COUNTY**

1112 Manatee Avenue West  
Bradenton, FL 34205

WSP PROJECT NO:  
600865X4

90% FOR PERMITTING

REVISIONS		
NO.	DATE	APPROVED

DESIGNED BY:	---
DRAWN BY:	---
CHECKED BY:	---
APPROVED BY:	---
DATE:	9/9/24

SHEET TITLE:  
  
COVER PAGE

SHEET NUMBER:	REV. #
COV	-
SHEET 1 OF - SHEETS	

LOCATED IN  
SECTION 19, TOWNSHIP 34 SOUTH, RANGE 17 EAST  
BRADENTON, FLORIDA

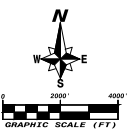

ATTENTION IS DIRECTED TO THE FACT THAT THESE PLANS MAY HAVE BEEN CHANGED IN SIZE BY REPRODUCTION. THIS MUST BE CONSIDERED WHEN OBTAINING SCALED DATA.

GOVERNING SPECIFICATIONS:  
THE PROJECT DEVELOPMENT CODE:  
MANATEE PUBLIC WORKS MANUAL DATED SEPTEMBER 1993;  
FLORIDA DEPARTMENT OF TRANSPORTATION (FDOT) DESIGN STANDARDS 2010;  
FLORIDA DEPARTMENT OF ENVIRONMENTAL PROTECTION (FDEP);  
SOUTHWEST FLORIDA WATER MANAGEMENT DISTRICT (SWFWMD);  
UNITED STATES ARMY CORPS OF ENGINEERS (USACE);  
CITY OF BRADENTON BEACHS;  
IN THE EVENT OF A CONFLICT, THE MOST RESTRICTIVE APPLIES.

- DISTRICT 1  
OPEN SEAT
- DISTRICT 2  
AMANDA GALLARD
- DISTRICT 3  
KEVIN VAN OSTENBRIDGE
- DISTRICT 4  
MIKE RAIN
- DISTRICT 5  
RAY TURNER
- DISTRICT 6  
JASON BEARDEN
- DISTRICT 7  
GEORGE KRUSE
- COUNTY ADMINISTRATOR  
CHARLIE BISHOP
- PARKS & NATURAL RESOURCES DIRECTOR  
CHARLIE HUNSICKER

PLANS PREPARED FOR:  
MANATEE COUNTY  
ECOLOGICAL AND MARINE SERVICES DIVISION  
5502 33RD AVE DR W, BRADENTON, FL 34209  
PHONE: 941-742-9923

PLANS PREPARED BY:  
WSP USA, INC.  
1101 CHANNELSIDE DR, SUITE 200  
TAMPA, FLORIDA 33602  
E-MAIL: greg.corning@wsp.com  
ENGINEER OF RECORD: GREGORY CORNING, P.E. (FL 79293)

Sheet Number	Sheet Title
COV	COVER PAGE
G-001	GENERAL NOTES
C-101	EXISTING SITE PLAN
C-102	DEMOLITION PLAN
C-103	PROPOSED SITE PLAN
C-104	EROSION AND SEDIMENT CONTROLS PLAN
C-105	PLANTING PLAN
C-301	CROSS SECTION 1 OF 2
C-302	CROSS SECTION 2 OF 2
C-303	SIDEWALK PROFILE
C-501	DESIGN DETAILS 1 OF 2
C-502	DESIGN DETAILS 2 OF 2

VICINITY MAP

SUNSHINE STATE ONE CALL OF FLORIDA  
CALL BEFORE YOU DIG  
1-800432-4770

Know what's below.  
Call before you dig.

1. CALL 1-800-432-4770 TWO FULL BUSINESS DAYS (BUT NOT MORE THAN FIVE) BEFORE DIGGING TO FIND OUT WHERE BURIED FACILITIES (ELECTRIC, GAS, TELECOMMUNICATIONS, CABLE/WATER, SEWER) ARE LOCATED.
2. WAIT THE REQUIRED TIME FOR THE UTILITIES ON SITE TO BE LOCATED AND MARKED WITH COLOR-CODED PAINT, FLAGS OR STAKES AND CONFIRM THAT THE SITE HAS BEEN LOCATED.
3. RESPECT AND PROTECT THE MARKS DURING THE PROJECT. IF MARKS ARE DESTROYED, REQUEST A NEW LOCATE TICKET.
4. DIG SAFELY. USING EXTREME CAUTION WHEN DIGGING WITHIN 24 INCHES ON EITHER SIDE OF THE MARKS TO AVOID HITTING THE BURIED UTILITY LINES.

NOTES:

A. GENERAL

- PROPERTY OWNER'S NAME AND ADDRESS:  
MANATEE COUNTY  
1112 MANATEE AVENUE WEST  
BRADENTON, FL 34205  
PARCEL ID# 2995600009  
PROJECT LOCATION: LAT: 27°31'10.02"N LONG: 82°38'0.13"W
- DESCRIPTION:
- THE TYPES OF SOIL DISTURBANCE ACTIVITIES INCLUDE: GRADING AND EXCAVATING
- CONSTRUCTION AND DEMOLITION DEBRIS SHOULD BE REMOVED FROM THE SITE AND DISPOSED ACCORDING TO FLORIDA DEPARTMENT OF ENVIRONMENTAL PROTECTION CHAPTER 62-701.
- SEQUENCE OF MAJOR ACTIVITIES:  
a. INSTALL TEMPORARY EROSION AND SEDIMENTATION CONTROLS AND MAINTAIN THROUGHOUT PROJECT.  
b. CONSTRUCT STAGING AREAS.  
c. CONSTRUCT FEATURES ACCORDING TO ENGINEERING DESIGN PLANS AND TECHNICAL SPECIFICATIONS.  
d. OBTAIN FINAL APPROVAL, REMOVE EROSION AND SEDIMENTATION CONTROLS AND STABILIZE ANY AREA DISTURBED BY THEIR REMOVAL.
- AREA ESTIMATES: TOTAL PARCEL BOUNDARY = 0.21 ACRES.
- IT IS THE RESPONSIBILITY OF THE CONTRACTOR TO DEVELOP AND IMPLEMENT A STORMWATER POLLUTION PREVENTION PLAN (SWPPP) IN ACCORDANCE WITH THE EPA NPDES GENERAL PERMIT FOR STORMWATER DISCHARGES FROM CONSTRUCTION ACTIVITIES, THE TCEQ GENERAL PERMIT FOR STORMWATER DISCHARGES FROM CONSTRUCTION ACTIVITIES AND ALL OTHER FEDERAL, STATE AND LOCAL REQUIREMENTS.
- MANATEE COUNTY AND THE CONTRACTOR SHALL HAVE A PRE-CONSTRUCTION MEETING TO DISCUSS THE COMPLEXITY AND POTENTIAL PUBLIC CONCERNS WITH THE PROJECT.
- BEARINGS, DISTANCES, COORDINATES & ELEVATIONS SHOWN HEREON ARE RELATIVE TO THE NORTH AMERICAN VERTICAL DATUM OF 1988 (NAVD 88), RESPECTIVELY, BASED ON NATIONAL SPATIAL REFERENCE SYSTEM CONTROL STATIONS:
- ANY MATERIAL TO BE STOCKPILED FOR PERIODS GREATER THAN 24 HOURS SHALL BE PROTECTED BY THE APPROPRIATE EROSION CONTROL MEASURES.
- THE CONTRACTOR IS ALERTED TO THE PRESENCE OF OVERHEAD WIRES AND POLES IN THE AREA. THE METHOD OF CONSTRUCTION FOR THESE LOCATIONS MUST COMPLY WITH OSHA SAFETY STANDARDS. THE CONTRACTOR SHALL INSPECT THESE SITES AND WILL BE RESPONSIBLE FOR DETERMINING WHAT METHOD OF PREPARATION AND INSTALLATION WILL BE USED TO COMPLY WITH THESE REQUIREMENTS. THE METHOD OF PREPARATION AND INSTALLATION MUST HAVE THE ENGINEER'S AND UTILITY OWNER'S APPROVAL.
- ANY DISCREPANCIES BETWEEN THE PLANS AND ACTUAL FIELD CONDITIONS SHALL BE BROUGHT TO THE ATTENTION OF THE ENGINEER OF RECORD.
- NO FIELD CHANGES OR DEVIATIONS FROM THE DESIGN ARE TO BE MADE WITHOUT PRIOR APPROVAL OF THE ENGINEER OF RECORD.

B. TEMPORARY EROSION AND SEDIMENT CONTROL

- CONTRACTOR SHALL INSTALL PRIOR TO AND MAINTAIN DURING CONSTRUCTION ALL SEDIMENT CONTROL MEASURES AS REQUIRED TO RETAIN ALL SEDIMENTS ON THE SITE. IMPROPER SEDIMENT CONTROL MEASURES MAY RESULT IN CODE ENFORCEMENT VIOLATIONS.
- ALL SILT FENCE AND FLOATING TURBIDITY BARRIERS MUST BE PLACED AS ACCESS IS OBTAINED DURING CLEARING. NO GRADING SHALL BE DONE UNTIL SILT FENCE AND TURBIDITY BARRIERS ARE INSTALLED.
- SILT FENCE AND FLOATING TURBIDITY BARRIERS ARE TO BE PLACED AS SHOWN AND/OR DIRECTED BY ENGINEER.
- EROSION CONTROL MEASURES WILL BE INSPECTED AT LEAST DAILY, AFTER EACH RAIN AND REPAIRED BY THE GENERAL CONTRACTOR, CLEAN OUT OF SEDIMENT CONTROL STRUCTURES WILL BE PERFORMED BY THE CONTRACTOR WHEN SEDIMENT HAS ACCUMULATED TO ONE-THIRD (1/3) OF THE HEIGHT OF THE INDIVIDUAL STRUCTURE FOR TEMPORARY SEDIMENT BASINS & RETROFITTED DETENTION PONDS, ONE-HALF (1/2) FULL FOR SILT FENCE, TURBIDITY BARRIERS, CHECK DAMS, ROCK FILTER DAMS, AND INLET SEDIMENT TRAPS.
- THE CONTRACTOR IS RESPONSIBLE FOR LOCATING SEDIMENT AND EROSION CONTROL MEASURES TO PROVIDE OPTIMUM SEDIMENT AND EROSION CONTROL. SEDIMENT AND EROSION CONTROL MEASURES SHALL COMPLY WITH STATE OF FLORIDA EROSION AND SEDIMENT CONTROL MANUAL, DATED JULY 2013.
- ADDITIONAL EROSION AND SEDIMENT CONTROL MEASURES SHALL BE INSTALLED IF DEEMED NECESSARY BY ON-SITE INSPECTION OF MANATEE COUNTY DESIGNATED REPRESENTATIVE.
- THE CONTRACTOR SHALL PROTECT ANY EXISTING DITCHES, WETLAND VEGETATION, STORM DRAIN PIPES, AND INLETS IN THE VICINITY OF WORK TO BE PERFORMED FROM DAMAGE OR SALTATION, WHETHER OR NOT SPECIFICALLY IDENTIFIED IN THE PLANS.
- EROSION CONTROL MEASURES DESCRIBED SHALL BE MAINTAINED UNTIL GRASS ON PLANTED SLOPES IS SUFFICIENTLY ESTABLISHED TO BE AN EFFECTIVE EROSION DETERRENT.
- ALL GRASSING SHALL BE IN ACCORDANCE WITH THE ATTACHED SPECIFICATIONS.
- CONSTRUCTION EXITS SHALL BE MAINTAINED IN A CONDITION WHICH WILL PREVENT TRACKING OR FLOW OF MUD INTO PUBLIC STREETS. IF TRACKING OR FLOW OF MUD OCCURS, CONTRACTOR SHALL CONSTRUCT A SOIL TRACKING PREVENTION DEVICE IN ACCORDANCE WITH FOOT DESIGN STANDARDS FY 2024-25, SECTION 104.
- TEMPORARY PROTECTION DEVICES MUST BE MAINTAINED UNTIL PROJECT COMPLETION OR VEGETATION MEASURES ARE ESTABLISHED.

C. EXISTING INFRASTRUCTURE

- THE CONTRACTOR IS RESPONSIBLE FOR REPLACING EXISTING INFRASTRUCTURE THAT IS IMPACTED DURING CONSTRUCTION TO MATCH EXISTING CONDITIONS. SEE CONSTRUCTION PLAN SHEET FOR DETAILS.

D. PERMITTING NOTES

- PERMITTING UNDER 62-3300.630 GENERAL PERMIT FOR ENVIRONMENTAL ENHANCEMENT
- IF IT IS PRESUMED THE ACTIVITIES DEFINED ARE ELIGIBLE FOR THIS PERMIT BASED ON THE FOLLOWING:
  - NO ACTIVITIES OCCUR ON SANDY BEACHES THAT FRONT THE ATLANTIC OCEAN, THE GULF OF MEXICO, OR THE STRAIGHTS OF FLORIDA.
  - NO MITIGATION FOR ANOTHER ACTIVITY IS PROPOSED
  - THE ACTIVITIES DO NOT INVOLVE REPLACING A NATURAL BIOLOGICAL COMMUNITY WITH A DIFFERENT TYPE.
  - THE ACTIVITIES DO NOT ADVERSELY AFFECT ANIMAL OR PLANT SPECIES THAT ARE LISTED AS ENDANGERED, THREATENED OR OF SPECIAL CONCERN.
  - ACTIVITIES PROPOSED DO NOT IMPACT HISTORICAL PROPERTIES DEFINED ON THE NATIONAL REGISTER OF HISTORICAL PLACES UNDER THE PROVISIONS OF SECTION 267.061, F.S.
  - THE ACTIVITIES ARE NOT PART OF THE CENTRAL AND SOUTHERN FLORIDA FLOOD CONTROL PROJECT, THEREFORE DO NOT REQUIRE A PERMIT UNDER SECTION 373.1502, F.S., NOR ARE ANY ACTIVITIES AUTHORIZED UNDER SECTION 528 OF THE WATER RESOURCES DEVELOPMENT ACT OF 1996, PUBLIC LAW 104-303 (CRITICAL RESTORATION PROJECTS), OCTOBER 12, 1996.
  - THE ACTIVITIES DO NOT MATCH ANY ACTIVITY AUTHORIZED UNDER SECTION 101(8) OF THE WATER RESOURCES DEVELOPMENT ACT OF 1992, PUBLIC LAW 102-580, (OCTOBER 31, 1992).
  - THE ACTIVITIES ARE PRESUMED TO NOT BE ASSOCIATED WITH OVERGLACES OR LAKE OKEECHOBEE RESTORATION.
- GRANT FUNDING AND ASSOCIATED DOCUMENTS WILL BE INCLUDED WHICH INCLUDE JUSTIFICATION DOCUMENTATION.
- ACTIVITIES UNDER THIS PERMIT ARE SUBJECT TO ADDITIONAL PROVISIONS AND LIMITATIONS AS FOLLOWS:
  - ACTIVITIES WILL NOT BE ELIGIBLE FOR USE AS FUTURE MITIGATION CREDIT FOR SEPARATE ACTIVITIES.
  - WILL NOT ADVERSELY AFFECT THE VALUE OF FUNCTIONS PROVIDED TO FISH AND WILDLIFE BY WETLANDS OR OTHER SURFACE WATERS.
  - WILL NOT CAUSE ADVERSE IMPACTS OUTLINED UNDER THIS SECTION.
  - THE DESIGN IS CAPABLE OF BEING PERFORMED AND FUNCTION AS PROPOSED
  - PRIMARY INTENT OF PROJECT IS TO ENHANCE THE AREAS RESILIENCY BY PROVIDING A COMBINATION OF HARDENED AND LIVING SHORELINE STABILIZATION.
- REQUIRED DOCUMENTS WILL BE SUPPLIED WITH PERMIT APPLICATION.
  - COPY OF COASTAL ZONE CONSISTENCY CONCURRENCE
  - FEDERAL FUNDING AUTHORIZATION DOCUMENTATION
  - N/A - NO FLOCCULENT PROPOSED
  - N/A - NO MIXING ZONE IS REQUIRED

E. PROTECTED SPECIES SIGHTINGS

THE ACTION AGENCY AND ANY PERMITTEE SHALL ENSURE THAT ALL PERSONNEL ASSOCIATED WITH THE PROJECT ARE INSTRUCTED ABOUT THE POTENTIAL PRESENCE OF SPECIES PROTECTED UNDER THE ENDANGERED SPECIES ACT (ESA) AND THE MARINE MAMMAL PROTECTION ACT (MMPA). ALL ON-SITE PROJECT PERSONNEL ARE RESPONSIBLE FOR OBSERVING WATER-RELATED ACTIVITIES FOR THE PRESENCE OF PROTECTED SPECIES. ALL PERSONNEL SHALL BE ADVISED THAT THERE ARE CIVIL AND CRIMINAL PENALTIES FOR HARMING, HARASSING, OR KILLING LISTED SPECIES AND ALL MARINE MAMMALS; TO DETERMINE WHICH PROTECTED SPECIES AND CRITICAL HABITAT MAY BE FOUND IN THE TRANSIT AREA, PLEASE REVIEW THE RELEVANT MARINE MAMMAL AND ESA-LISTED SPECIES AT FIND A SPECIES (HTTPS://WWW.FISHERIES.NOAA.GOV/FINDSPECIES) AND THE CONSULTATION DOCUMENTS THAT HAVE BEEN COMPLETED FOR THE PROJECT.

1. EQUIPMENT:  
TURBIDITY CURTAINS, IF USED, SHALL BE MADE OF MATERIAL IN WHICH PROTECTED SPECIES CANNOT BECOME ENTAILED AND BE REGULARLY MONITORED TO AVOID PROTECTED SPECIES ENTRAPMENT. ALL TURBIDITY CURTAINS AND OTHER IN-WATER EQUIPMENT SHALL BE PROPERLY SECURED WITH MATERIALS THAT REDUCE THE RISK OF PROTECTED SPECIES ENTAILED AND ENTRAPMENT.

- IN-WATER LINES (ROPE, CHAIN, AND CABLE, INCLUDING THE LINES TO SECURE TURBIDITY CURTAINS) SHALL BE STIFF, TAUT, AND NON-LOOPING. EXAMPLES OF SUCH LINES ARE HEAVY METAL CHAINS OR HEAVY CABLES THAT DO NOT READILY LOOP AND TANGLE. FLEXIBLE IN-WATER LINES, SUCH AS NYLON ROPE OR ANY LINES THAT COULD LOOP OR TANGLE, SHALL BE ENCLOSED IN A PLASTIC OR RUBBER SLEEVE/TUBE TO ADD RIGIDITY AND PREVENT THE LINE FROM LOOPING AND TANGLING. IN ALL INSTANCES, NO EXCESS LINE SHALL BE ALLOWED IN THE WATER. ALL ANCHORING SHALL BE IN AREAS FREE FROM HARBORBOTTOM AND SEAGRASS.
- TURBIDITY CURTAINS AND OTHER IN-WATER EQUIPMENT SHALL BE PLACED IN A MANNER THAT DOES NOT ENTRAP PROTECTED SPECIES WITHIN THE PROJECT AREA AND MINIMIZE THE EXTENT AND DURATION OF THEIR EXCLUSION FROM THE PROJECT AREA.
- TURBIDITY BARRIERS SHALL BE POSITIONED IN A WAY THAT MINIMIZES THE EXTENT AND DURATION OF PROTECTED SPECIES EXCLUSION FROM IMPORTANT HABITAT (E.G. CRITICAL HABITAT, HARBORBOTTOM, SEAGRASS) IN THE PROJECT AREA.

2. OPERATIONS:  
FOR CONSTRUCTION WORK THAT IS GENERALLY STATIONARY (E.G., BARGE-MOUNTED EQUIPMENT DREDGING A BERTH OR SECTION OF RIVER, OR SHORE-BASED EQUIPMENT EXTENDING INTO THE WATER):

- OPERATIONS OF MOVING EQUIPMENT SHALL CEASE IF A PROTECTED SPECIES IS OBSERVED WITHIN 150 FEET OF OPERATIONS.
- ACTIVITIES SHALL NOT RESUME UNTIL THE PROTECTED SPECIES HAS DEPARTED THE PROJECT AREA OF ITS OWN VOLITION (E.G., SPECIES WAS OBSERVED DEPARTING OR 20 MINUTES HAVE PASSED SINCE THE ANIMAL WAS LAST SEEN IN THE AREA).

3. VESSELS:  
FOR PROJECTS REQUIRING VESSELS, THE ACTION AGENCY, AND ANY PERMITTEE SHALL ENSURE CONDITIONS IN THE VESSEL STRIKE AVOIDANCE MEASURES ARE IMPLEMENTED AS PART OF THE PROJECT/PERMIT ISSUANCE (HTTPS://WWW.FISHERIES.NOAA.GOV/SOUTHEAST/CONSULTATIONS/REGULATIONS-POLICES-ANDQUIDANCE).

4. CONSULTATION REPORTING REQUIREMENT  
ANY INTERACTION WITH A PROTECTED SPECIES SHALL BE REPORTED IMMEDIATELY TO NOAA FISHERIES SERO PRD AND THE LOCAL AUTHORIZED STRANDING/RESUE ORGANIZATION.  
TO REPORT TO NOAA FISHERIES SERO PRD, SEND AN EMAIL TO TAKEREPORT.NMFS.SERO@NOAA.GOV. PLEASE INCLUDE THE SPECIES INVOLVED, THE CIRCUMSTANCES OF THE INTERACTION, THE DATE AND DISPOSITION OF THE SPECIES INVOLVED, PHOTOS (IF AVAILABLE), AND CONTACT INFORMATION FOR THE PERSON WHO CAN PROVIDE ADDITIONAL DETAILS IF REQUESTED. PLEASE INCLUDE THE PROJECTS ENVIRONMENTAL CONSULTATION ORGANIZER (ECO) NUMBER AND PROJECT TITLE IN THE SUBJECT LINE OF EMAIL REPORTS.  
TO REPORT THE INTERACTION TO THE LOCAL STRANDING/RESUE ORGANIZATION, PLEASE SEE THE FOLLOWING WEBSITE FOR THE MOST UP TO DATE INFORMATION FOR REPORTING SICK, INJURED, OR DEAD PROTECTED SPECIES:  
REPORTING HOTLINES:  
TO REPORT AN ESA OR MMPA VIOLATION, CALL THE NOAA FISHERIES ENFORCEMENT HOTLINE. THIS HOTLINE IS AVAILABLE 24 HOURS A DAY, 7 DAYS WEEK FOR ANYONE IN THE UNITED STATES.  
NOAA FISHERIES ENFORCEMENT HOTLINE: (800) 853-1964

5. ADDITIONAL CONDITIONS:  
ANY SPECIAL CONSTRUCTION CONDITIONS, REQUIRED OF YOUR SPECIFIC PROJECT, OUTSIDE THESE GENERAL CONDITIONS, IF APPLICABLE, WILL BE ADDRESSED IN THE PROJECT CONSULTATION AND MUST ALSO BE COMPLIED WITH

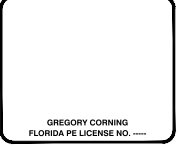

PROJECT:  
**BISHOP POINT LIVING SHORELINE DESIGN AND PERMITTING**  
BRADENTON, FLORIDA



90% FOR PERMITTING

REVISIONS			
NO.	DATE	BY	APPROVED

DESIGNED BY: ---  
DRAWN BY: ---  
CHECKED BY: ---  
APPROVED BY: ---  
DATE: 9/9/24

SHEET TITLE:  
**GENERAL NOTES**

SHEET NUMBER: G-01 REV. # -  
SHEET 1 OF - SHEETS

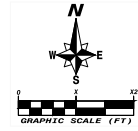
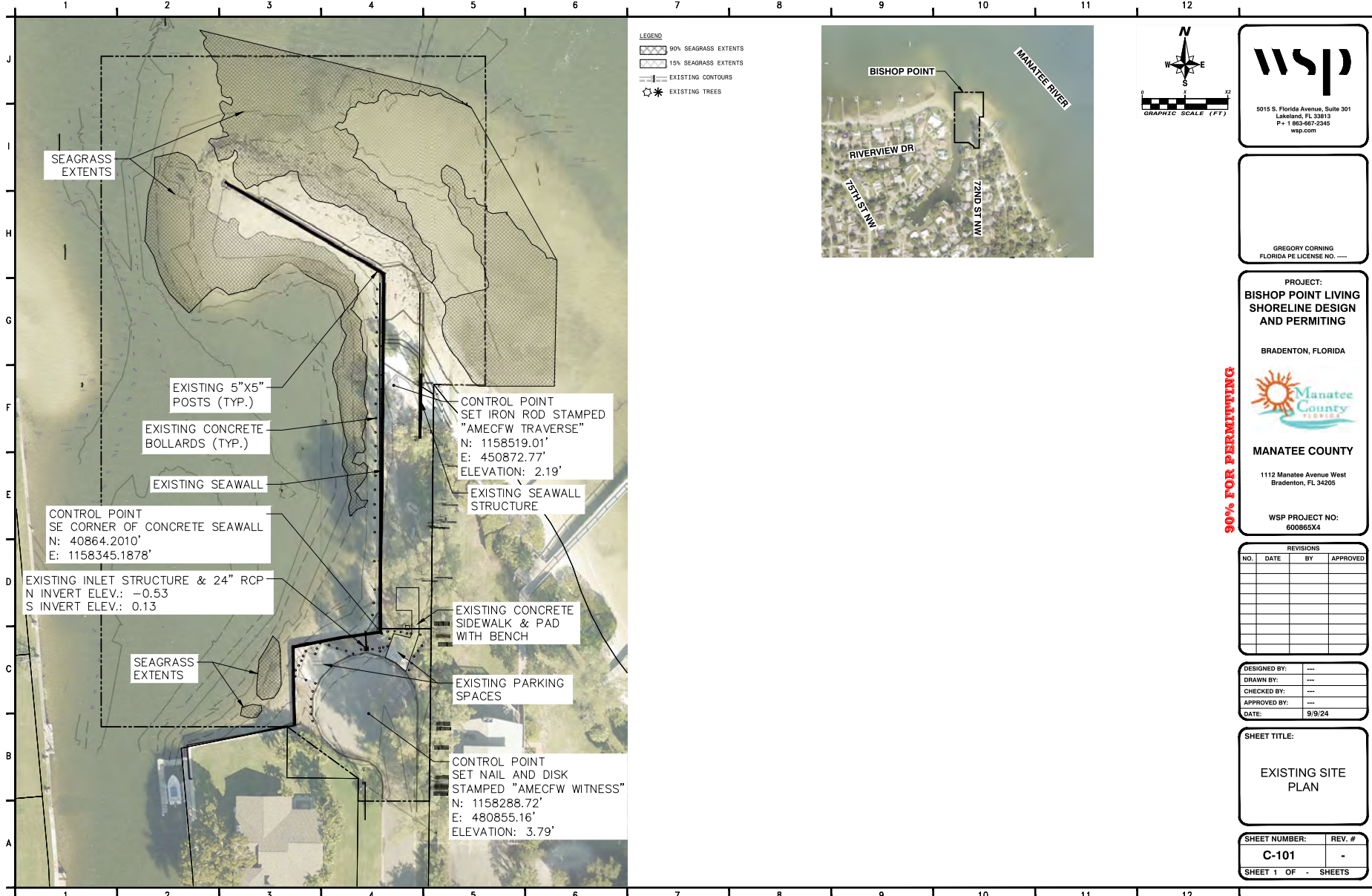

**wsp**

5015 S. Florida Avenue, Suite 301  
Lakeland, FL 33813  
P+ 1 888-687-2345  
wsp.com

GREGORY CORNING  
FLORIDA PE LICENSE NO. ....

**PROJECT:**  
**BISHOP POINT LIVING**  
**SHORELINE DESIGN**  
**AND PERMITTING**

BRADENTON, FLORIDA

**Manatee County**

**MANATEE COUNTY**

1112 Manatee Avenue West  
Bradenton, FL 34205

WSP PROJECT NO:  
600865X4

90% FOR PERMITTING

REVISIONS			
NO.	DATE	BY	APPROVED

DESIGNED BY: ---  
DRAWN BY: ---  
CHECKED BY: ---  
APPROVED BY: ---  
DATE: 9/9/24

SHEET TITLE:  
**EXISTING SITE PLAN**

SHEET NUMBER: C-101  
REV. # -  
SHEET 1 OF - SHEETS

C:\Users\USTC71464\OneDrive - WSP\Documents\Projects\600865 - Bishop Point\Shoreline\_Plan\_101\_Plan\_3.30.24\_Rev001.dwg - EXISTING 09/10/2024 9:03pm USTC71464

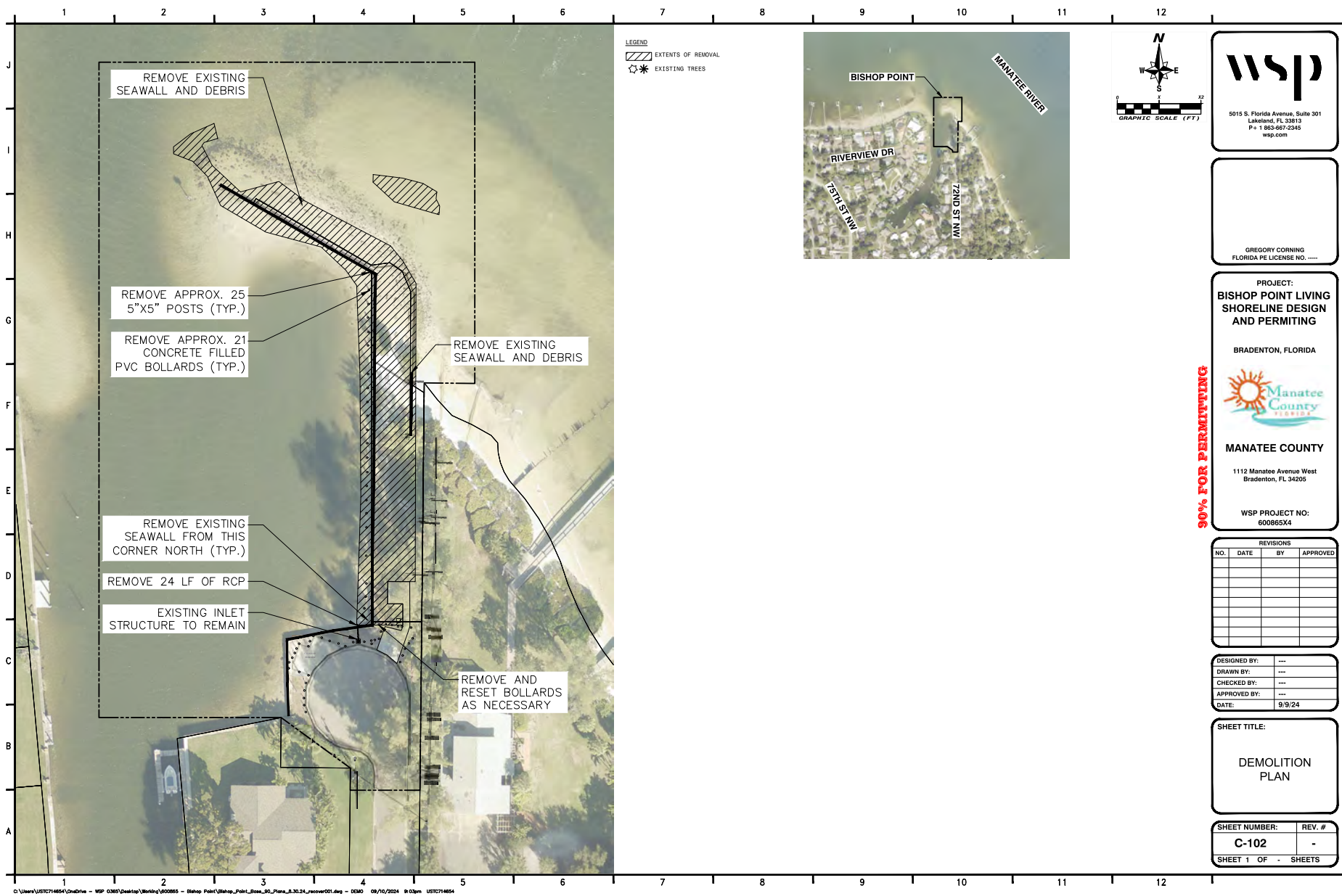

**wsp**

5015 S. Florida Avenue, Suite 301  
Lakeland, FL 33813  
P+ 1 863-687-2345  
wsp.com

GREGORY CORNING  
FLORIDA PE LICENSE NO. ....

PROJECT:  
**BISHOP POINT LIVING  
SHORELINE DESIGN  
AND PERMITTING**

BRADENTON, FLORIDA

**Manatee  
County  
FLORIDA**

MANATEE COUNTY

1112 Manatee Avenue West  
Bradenton, FL 34205

WSP PROJECT NO:  
600865X4

90% FOR PERMITTING

REVISIONS			
NO.	DATE	BY	APPROVED

DESIGNED BY: ---  
DRAWN BY: ---  
CHECKED BY: ---  
APPROVED BY: ---  
DATE: 9/9/24

SHEET TITLE:  
**DEMOLITION  
PLAN**

SHEET NUMBER:	REV. #
<b>C-102</b>	-
SHEET 1 OF - SHEETS	

C:\Users\JST2714654\OneDrive - WSP\OneDrive\Projects\600865 - Bishop Point\Bishop\_Point\_Living\_Shoreline\_S&P24\_Rev001.dwg - E260 09/10/2024 9:03am JST2714654

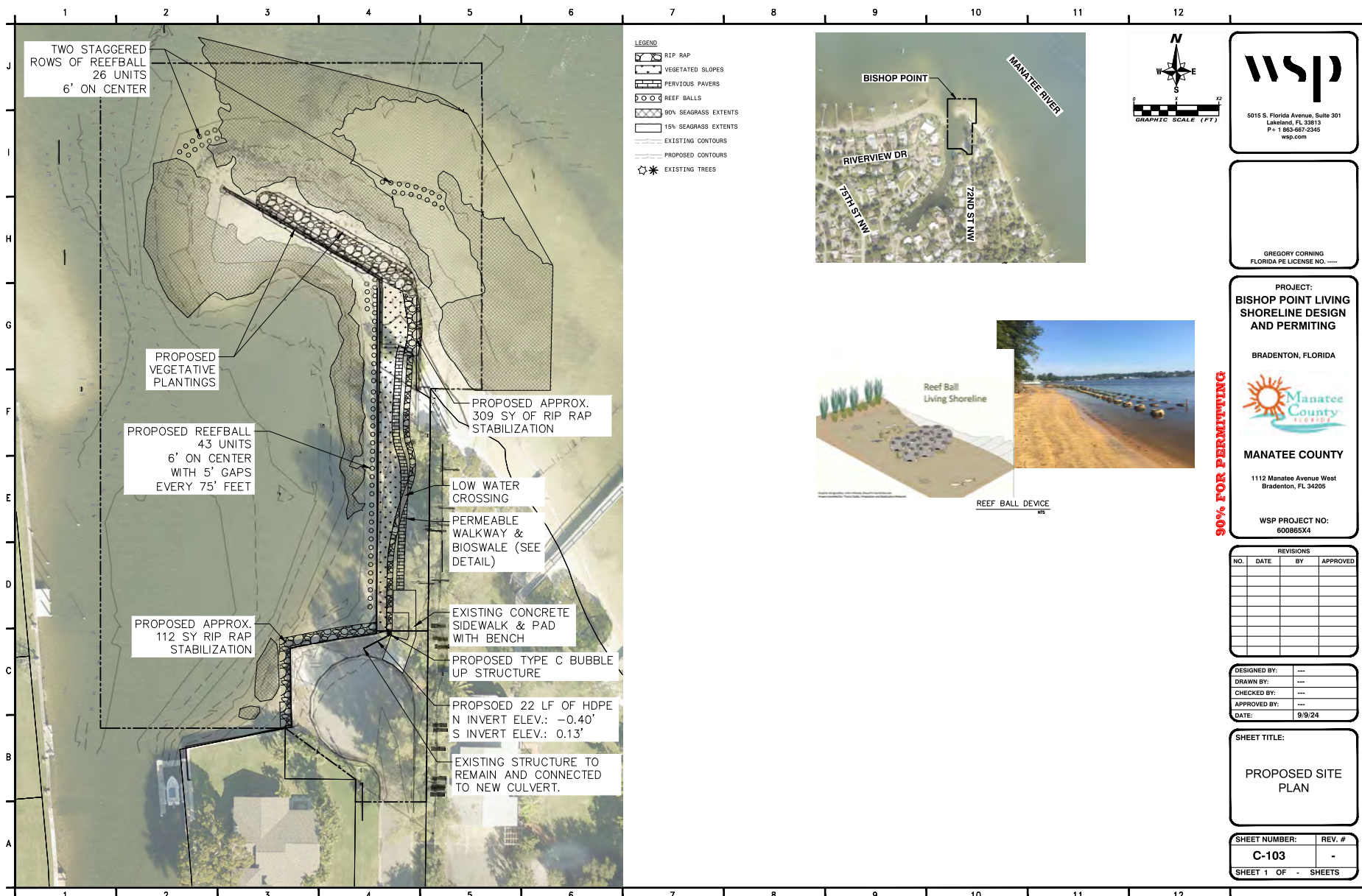

- LEGEND**
- RIP RAP
  - VEGETATED SLOPES
  - PERVIOUS PAVERS
  - REEF BALLS
  - 90% SEAGRASS EXTENTS
  - 15% SEAGRASS EXTENTS
  - EXISTING CONTOURS
  - PROPOSED CONTOURS
  - EXISTING TREES



**wsp**

5015 S. Florida Avenue, Suite 301  
Lakeland, FL 33813  
P+ 1 888-687-2345  
wsp.com

GREGORY CORNING  
FLORIDA PE LICENSE NO. ....

PROJECT:  
**BISHOP POINT LIVING SHORELINE DESIGN AND PERMITTING**  
BRADENTON, FLORIDA

**Manatee County**

MANATEE COUNTY  
1112 Manatee Avenue West  
Bradenton, FL 34205

WSP PROJECT NO:  
600865X4



90% FOR PERMITTING

REVISIONS			
NO.	DATE	BY	APPROVED

DESIGNED BY: ---  
DRAWN BY: ---  
CHECKED BY: ---  
APPROVED BY: ---  
DATE: 9/9/24

SHEET TITLE:  
**PROPOSED SITE PLAN**

SHEET NUMBER:	REV. #
C-103	-
SHEET 1 OF - SHEETS	

C:\Users\JSTC71464\OneDrive - WSP\OneDrive\Projects\600865 - Bishop Point\Bishop\_Point\_Living\_Shoreline\_RIP\_Rap\_8.30.24\_Rev02.dwg - PISP - MKED 09/10/2024 9:53pm JSTC71464

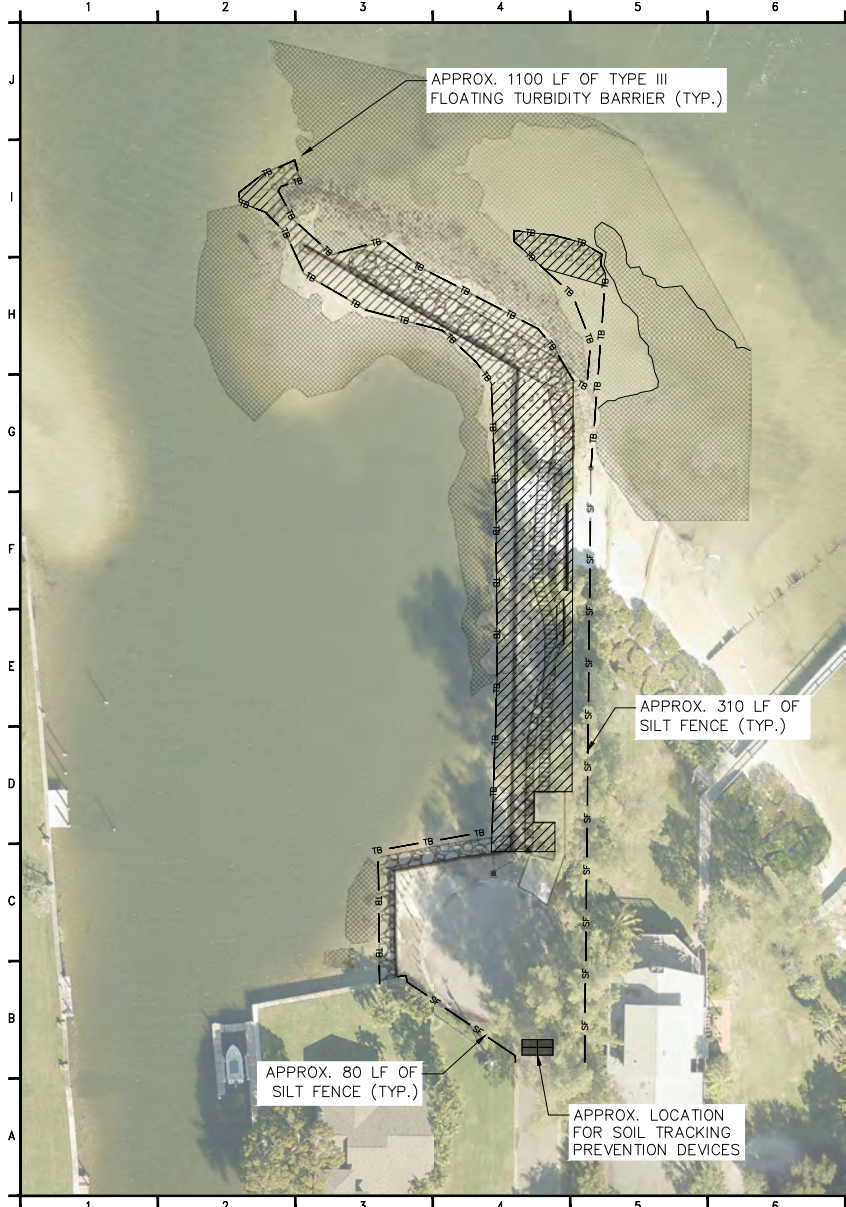

- LEGEND**
- RIP RAP
  - VEGETATED SLOPES
  - CONCRETE
  - PERVIOUS PAVERS
  - REEF BALLS
  - 90% SEAGRASS EXTENTS
  - 15% SEAGRASS EXTENTS
  - EXTENTS OF REMOVAL
  - SILT FENCE
  - TURBIDITY BARRIER
  - EXISTING TREES

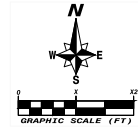
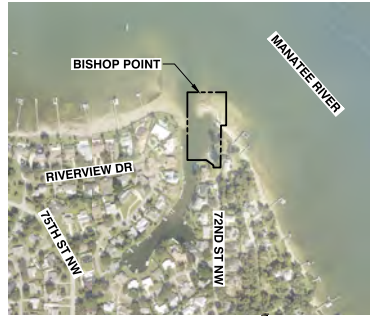

**wsp**

5015 S. Florida Avenue, Suite 301  
Lakeland, FL 33813  
P+ 1 888-687-2345  
wsp.com

GREGORY CORNING  
FLORIDA PE LICENSE NO. ....

**PROJECT:**  
**BISHOP POINT LIVING SHORELINE DESIGN AND PERMITTING**  
BRADENTON, FLORIDA

**Manatee County**  
FLORIDA

**MANATEE COUNTY**  
1112 Manatee Avenue West  
Bradenton, FL 34205

**90% FOR PERMITTING**

**WSP PROJECT NO:**  
600865X4

REVISIONS			
NO.	DATE	BY	APPROVED

DESIGNED BY:	---
DRAWN BY:	---
CHECKED BY:	---
APPROVED BY:	---
DATE:	9/9/24

**SHEET TITLE:**  
**EROSION AND SEDIMENT CONTROLS PLAN**

<b>SHEET NUMBER:</b>	<b>REV. #</b>
<b>C-104</b>	<b>-</b>
<b>SHEET 1 OF - SHEETS</b>	

C:\Users\JG1271464\OneDrive - WSP\Desktop\Bishop\600865 - Bishop Point\Bishop\_Plan\_Live\_30\_124\_Rev0924.dwg - EROSION CONTROL 09/10/2024 10:03pm JG1271464

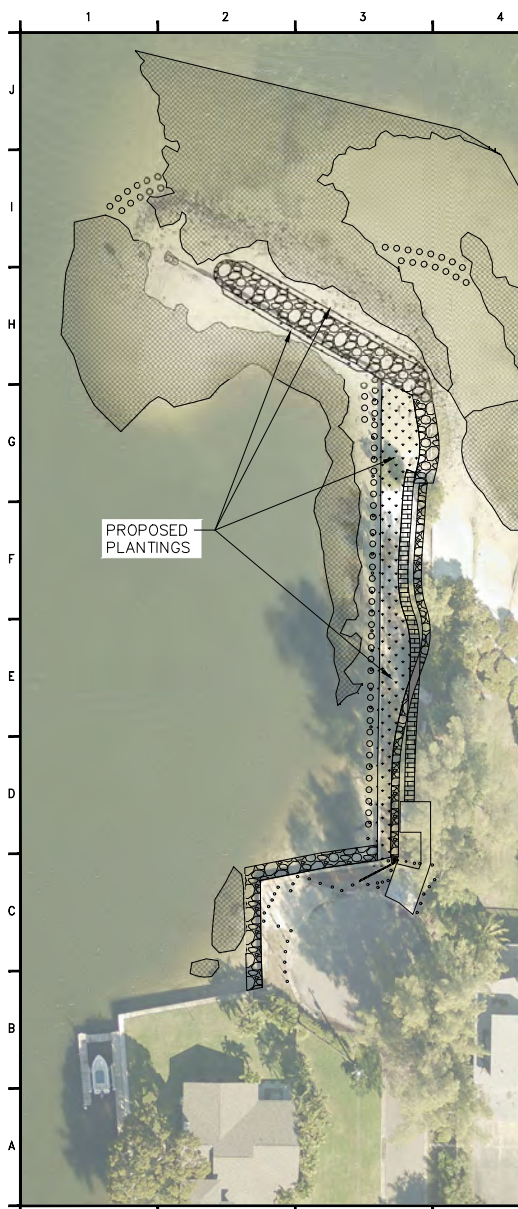

- LEGEND**
- RIP RAP
  - VEGETATED SLOPES
  - CONCRETE
  - PERVIOUS PAVERS
  - REEF BALLS
  - 90% SEAGRASS EXTENTS
  - 15% SEAGRASS EXTENTS
  - EXTENTS OF REMOVAL
  - SILT FENCE
  - TURBIDITY BARRIER
  - EXISTING TREES

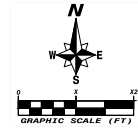

**wsp**

5015 S. Florida Avenue, Suite 301  
Lakeland, FL 33813  
P+ 1 888-687-2345  
wsp.com

GREGORY CORNING  
FLORIDA PE LICENSE NO. ....

**PROJECT:**  
BISHOP POINT LIVING  
SHORELINE DESIGN  
AND PERMITTING



BRADENTON, FLORIDA

**MANATEE COUNTY**

1112 Manatee Avenue West  
Bradenton, FL 34205

**WSP PROJECT NO:**  
600865X4

**90% FOR PERMITTING**

Elevation Range for Planting (NAVD88)	Zone Name	Area (SQ FT)	Common Name	Scientific Name	Installation Size	Min. Spacing (in)	Percent Coverage	Quantity	Unit	Comments
Below MSL (-0.43)	Zone 1 - Subtidal	400	Turtle Grass	<i>Thalassia testudinum</i>	--	--	--	--	--	Recruitment Only
			Shoal Grass	<i>Halodule wrightii</i>	--	--	--	--	--	
			Manatee Grass	<i>Syringodium filiforme</i>	--	--	--	--	--	
MSL to TOB (-0.43 to 1.47/2.25)	Zone 2 - Slope	1435	Red Mangroves	<i>Rhizophora mangle</i>	--	--	--	--	EA	Recruitment Only
			Black Mangroves	<i>Avicennia germinans</i>	--	--	--	--	EA	
			Saltmarsh Bullrush	<i>Schoenoplectus robustus</i>	4" LN	12" OC	10%			Slope
			Black Needlerush	<i>Juncus roemerianus</i>	4" LN	12" OC	10%			
			Saltmarsh Cordgrass	<i>Sporobolus alternifolius (aka Spartina alterniflora)</i>	4" LN	12" OC	60%			
			Saltmeadow Cordgrass	<i>Sporobolus pumilus (aka Spartina patens)</i>	4" LN	12" OC	20%			Top of Slope Only
TOB (1.47/2.25)	Zone 3 - Top of Bank	712	Seagrape	<i>Coccoloba uvifera</i>	1 G	--	10%		EA	Cluster of three (3) every 25ft.
			Buttonwood	<i>Conocarpus erectus</i>	1 G	--	10%		EA	
			Seaside Goldenrod	<i>Solidago sempervirens</i>	1 G	24" OC	10%		EA	Upper elevation limits
			Canada Goldenrod	<i>Solidago canadensis</i>	1 G	24" OC	10%		EA	
			Saltmeadow Cordgrass	<i>Sporobolus pumilus (aka Spartina patens)</i>	4" LN	12" OC	10%		EA	
			Sea Ox-eye Daisy	<i>Borrchia frutescens</i>	4" LN	12" OC	10%		EA	Slope
			Saltwort	<i>Batis maritima</i>	4" LN	12" OC	10%		EA	
			Sea Purslane	<i>Sesuvium portulacastrum</i>	4" LN	12" OC	10%		EA	
			Knot Grass	<i>Paspalum vaginatum</i>	4" LN	12" OC	20%		EA	
			Sand Cordgrass	<i>Sporobolus bakeri (aka Spartina bakeri)</i>	4" LN	12" OC	10%		EA	Upper Edge
Zone 4 - Swale	716	Sea Purslane	<i>Sesuvium portulacastrum</i>	4" LN	12" OC	10%		EA		
		Sea Ox-eye Daisy	<i>Borrchia frutescens</i>	4" LN	24" OC	20%		EA		
		Saltmeadow Cordgrass	<i>Sporobolus pumilus (aka Spartina patens)</i>	4" LN	12" OC	20%		EA	Slope	
		Canada Goldenrod	<i>Solidago canadensis</i>	1 G	12" OC	20%		EA		
		Knot Grass	<i>Paspalum vaginatum</i>	4" LN	12" OC	10%		EA		
		Sawgrass	<i>Cladium jamaicense</i>	4" LN	12" OC	10%		EA	Recruitment Only	

REVISIONS			
NO.	DATE	BY	APPROVED

DESIGNED BY: ---  
DRAWN BY: ---  
CHECKED BY: ---  
APPROVED BY: ---  
DATE: 9/9/24

**SHEET TITLE:**

PLANTING PLAN

**SHEET NUMBER:** C-105  
**REV. #** -  
SHEET 1 OF - SHEETS

C:\Users\J1571464\OneDrive - WSP\OneDrive\Work\60285 - Bishop Point\Bishop\_Plan\_Plot\_8.30.24\_Rev001.dwg - PLANTING 08/10/2024 9:03am 1:57:44PM



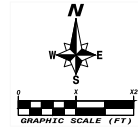
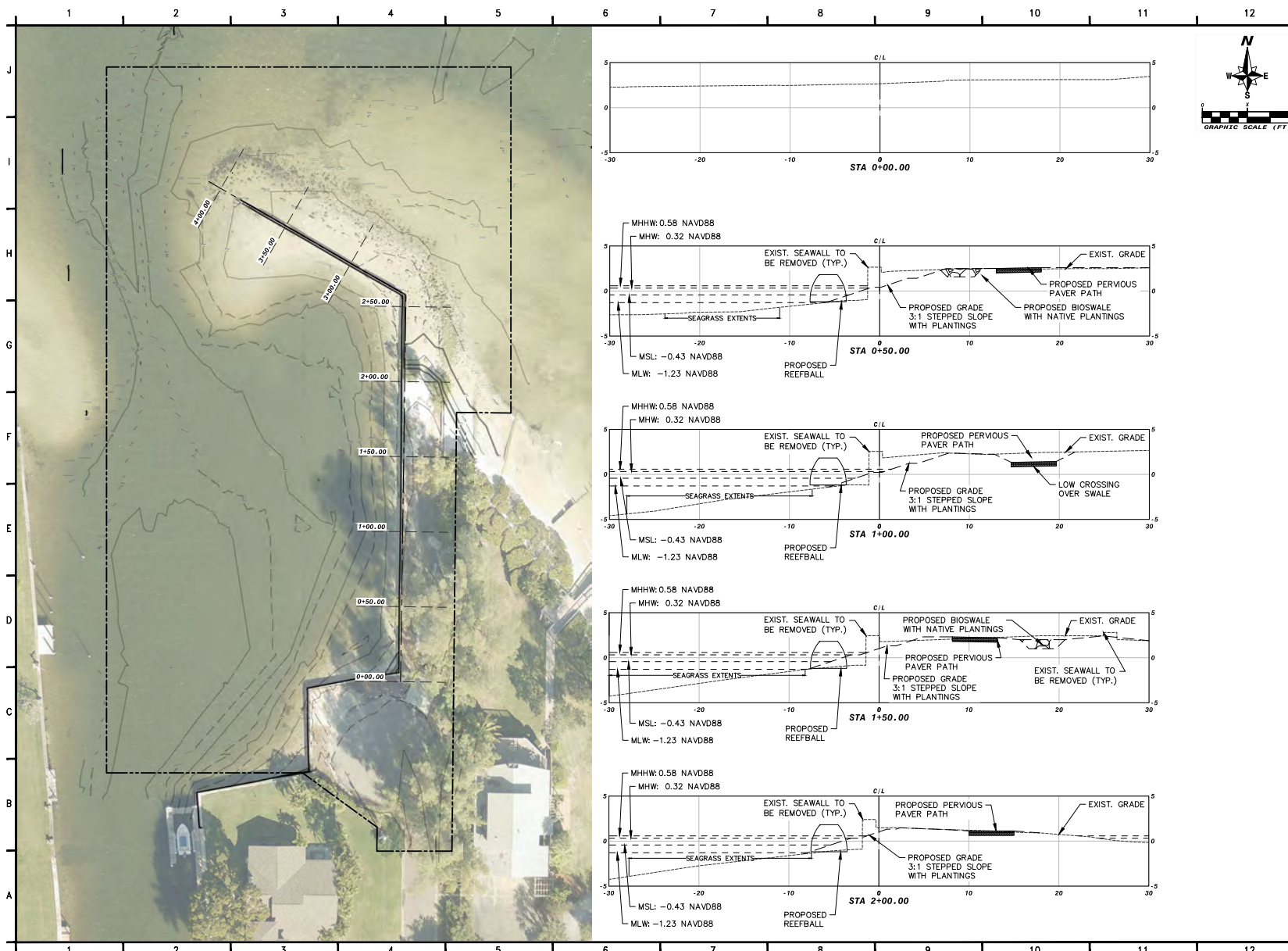

**wsp**

5015 S. Florida Avenue, Suite 301  
Lakeland, FL 33813  
P+ 1 888-687-2345  
wsp.com

GREGORY CORNING  
FLORIDA PE LICENSE NO. ....

PROJECT:  
**BISHOP POINT LIVING  
SHORELINE DESIGN  
AND PERMITTING**

BRADENTON, FLORIDA

**Manatee County**

MANATEE COUNTY

1112 Manatee Avenue West  
Bradenton, FL 34205

WSP PROJECT NO:  
600865X4

90% FOR PERMITTING

REVISIONS			
NO.	DATE	BY	APPROVED

DESIGNED BY: ---  
DRAWN BY: ---  
CHECKED BY: ---  
APPROVED BY: ---  
DATE: 9/9/24

SHEET TITLE:  
**CROSS SECTION  
1 OF 2**

SHEET NUMBER: **C-301**    REV. # -  
SHEET 1 OF - SHEETS

C:\Users\JST27464\OneDrive - WSP\OneDrive\Projects\600865 - Bishop Point\Shoreline\_Plan\_Sets\301\_Plan\_Sets\301\_2\cross\01.dwg - CROSS SECTIONS 09/10/2024 9:04pm JST27464

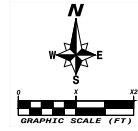
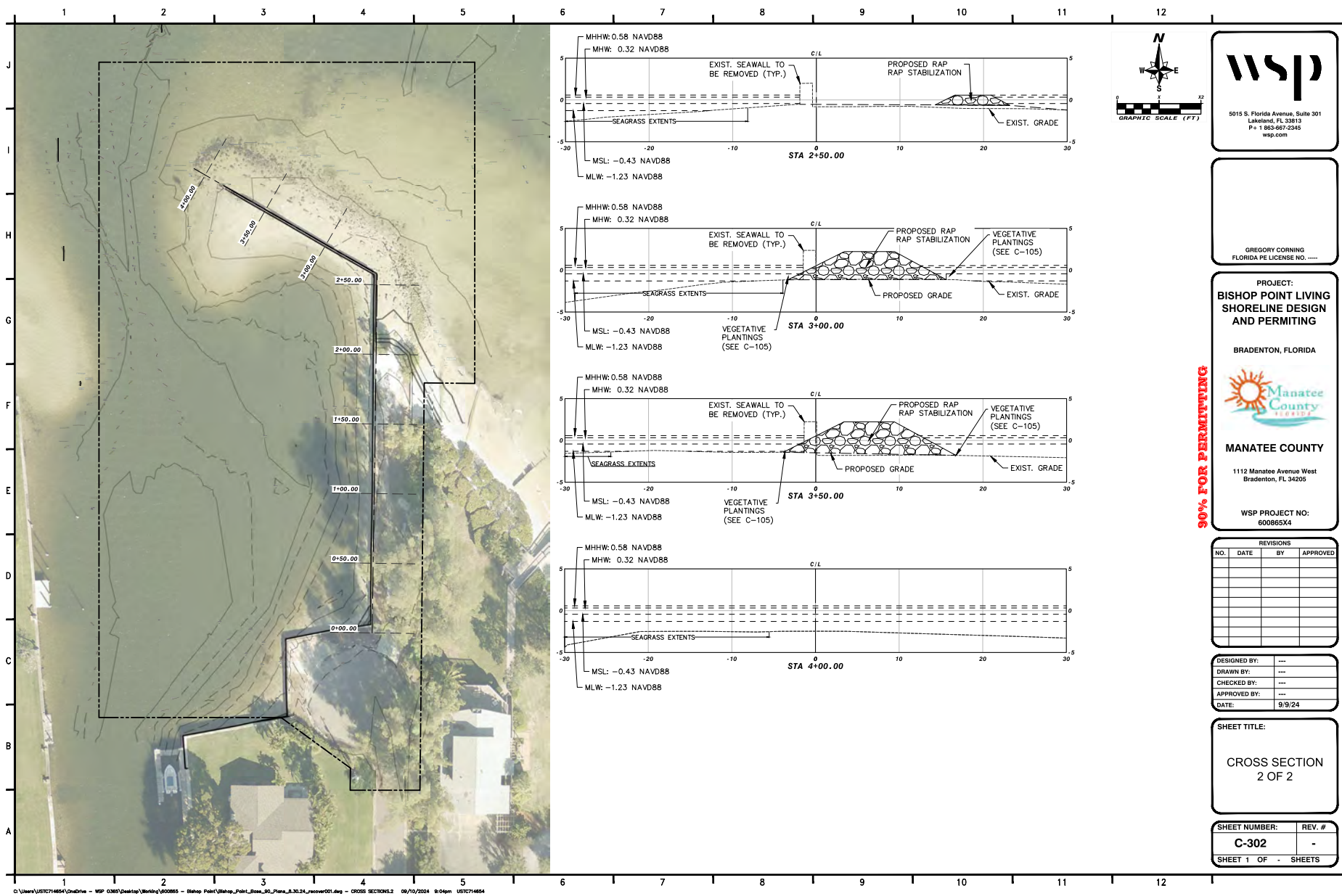

**wsp**

5015 S. Florida Avenue, Suite 301  
Lakeland, FL 33813  
P+ 1 888-687-2345  
wsp.com

GREGORY CORNING  
FLORIDA PE LICENSE NO. ....

PROJECT:  
**BISHOP POINT LIVING  
SHORELINE DESIGN  
AND PERMITTING**



BRADENTON, FLORIDA

**MANATEE COUNTY**

1112 Manatee Avenue West  
Bradenton, FL 34205

WSP PROJECT NO:  
600865X4

90% FOR PERMITTING

REVISIONS			
NO.	DATE	BY	APPROVED

DESIGNED BY: ---  
DRAWN BY: ---  
CHECKED BY: ---  
APPROVED BY: ---  
DATE: 9/9/24

SHEET TITLE:  
  
**CROSS SECTION  
2 OF 2**

SHEET NUMBER: <b>C-302</b>	REV. # -
SHEET 1 OF - SHEETS	

C:\Users\JST21464\OneDrive - WSP\OneDrive\Projects\600865 - Bishop Point\Bishop\_Point\_Site\_30124\_Rev\_01.dwg - CROSS SECTION.S 09/10/2024 9:04pm JST21464

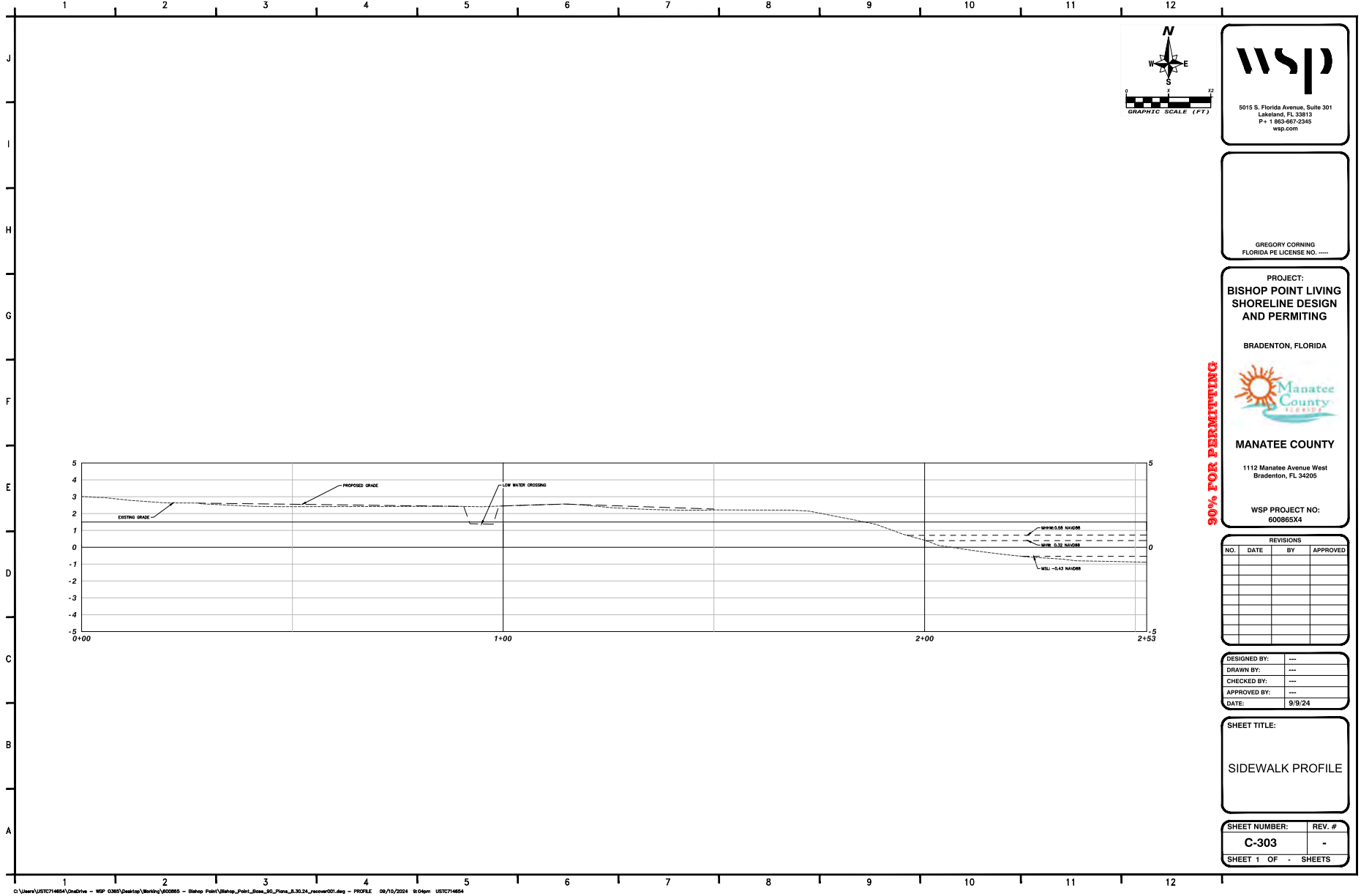

**wsp**  
 5015 S. Florida Avenue, Suite 301  
 Lakeland, FL 33813  
 P+ 1 888-687-2345  
 wsp.com

GREGORY CORNING  
 FLORIDA PE LICENSE NO. ....

PROJECT:  
**BISHOP POINT LIVING  
 SHORELINE DESIGN  
 AND PERMITTING**  
 BRADENTON, FLORIDA

**Manatee County**  
 FLORIDA  
**MANATEE COUNTY**  
 1112 Manatee Avenue West  
 Bradenton, FL 34205  
 WSP PROJECT NO:  
 600865X4

90% FOR PERMITTING

REVISIONS			
NO.	DATE	BY	APPROVED

DESIGNED BY:	---
DRAWN BY:	---
CHECKED BY:	---
APPROVED BY:	---
DATE:	9/9/24

SHEET TITLE:  
 SIDEWALK PROFILE

SHEET NUMBER:	REV. #
C-303	-
SHEET 1 OF - SHEETS	

c:\Users\JSTC714654\OneDrive - WSP\OneDrive\Work\600865 - Bishop Point\Shore\_Plan\_Rev\_3.30.24\acrow01.dwg - PROFILE 09/10/2024 8:04pm JSTC714654

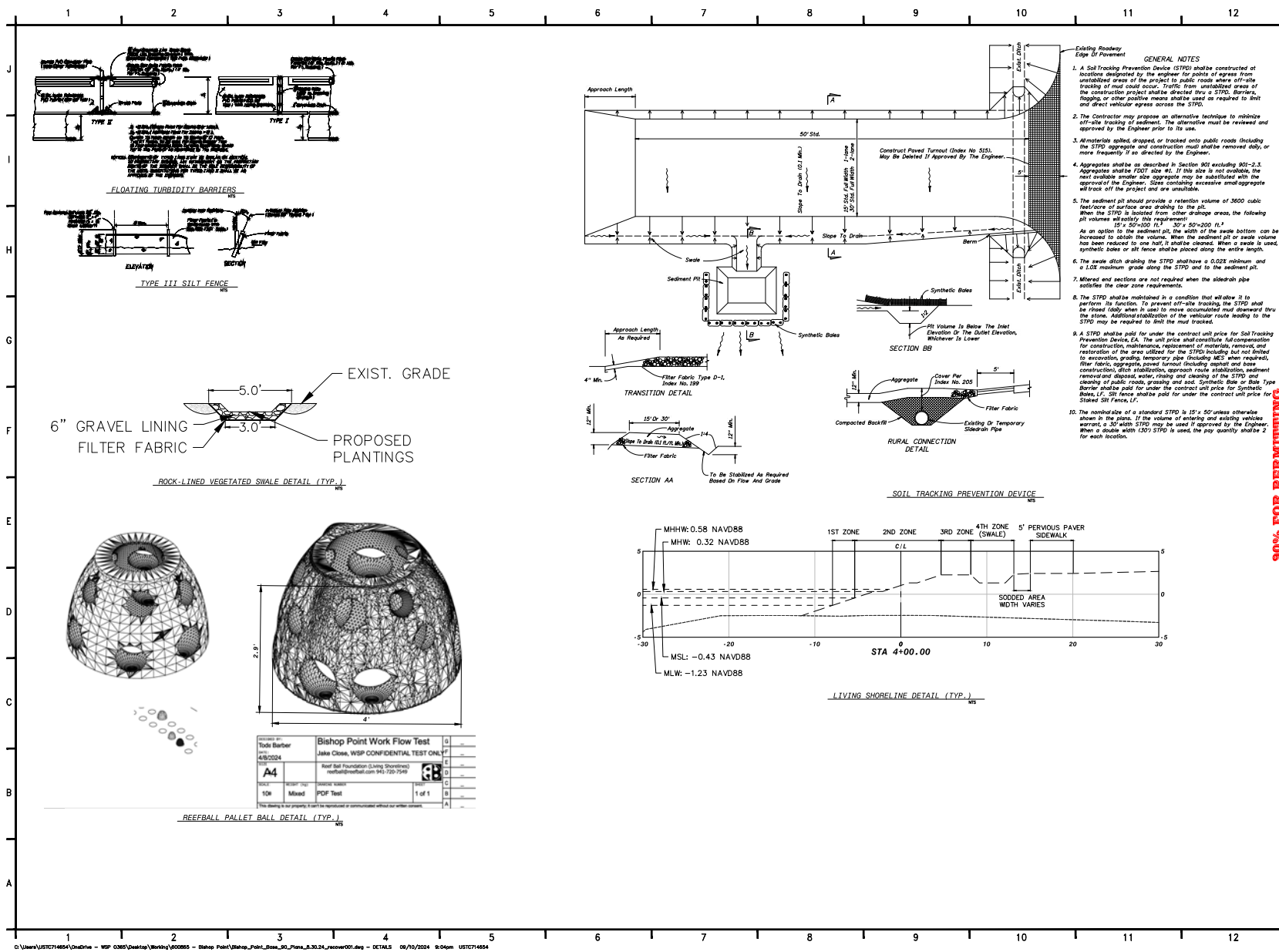

**WSP**

5015 S. Florida Avenue, Suite 301  
Lakeland, FL 33813  
P + 1 888-687-2345  
wsp.com

GREGORY CORNING  
FLORIDA PE LICENSE NO. ....

**PROJECT:**  
**BISHOP POINT LIVING SHORELINE DESIGN AND PERMITTING**

BRADENTON, FLORIDA

**MANATEE COUNTY**

1112 Manatee Avenue West  
Bradenton, FL 34205

**WSP PROJECT NO:**  
**600865X4**

**REVISIONS**

NO.	DATE	BY	APPROVED

DESIGNED BY: ---  
DRAWN BY: ---  
CHECKED BY: ---  
APPROVED BY: ---  
DATE: 9/9/24

**SHEET TITLE:**

**DESIGN DETAILS 1 OF 2**

**SHEET NUMBER:** C-501  
**REV. #** -  
**SHEET 1 OF - SHEETS**

90% FOR PERMITTING

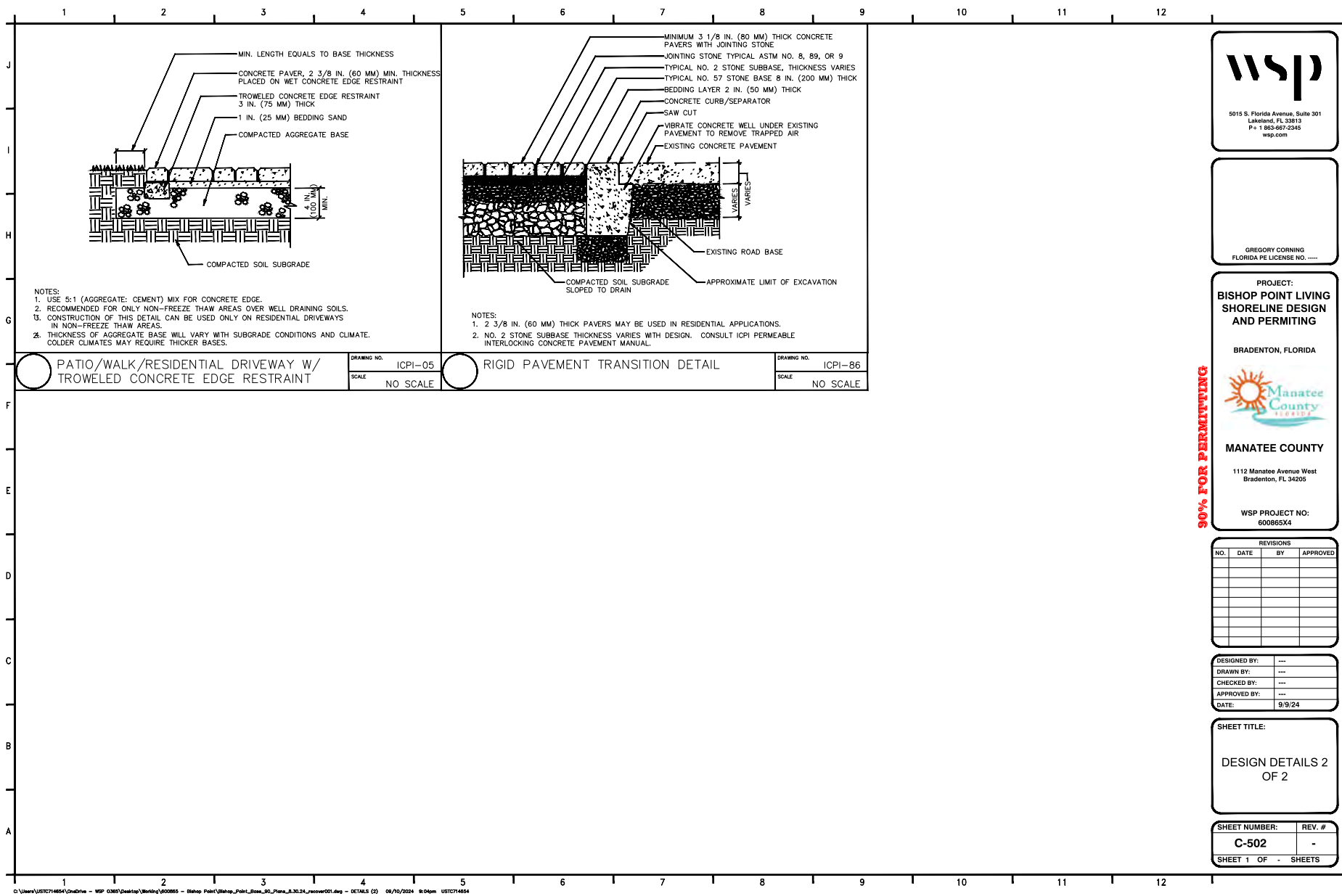

GREGORY CORNING  
FLORIDA PE LICENSE NO. ....

PROJECT:  
**BISHOP POINT LIVING  
SHORELINE DESIGN  
AND PERMITTING**

BRADENTON, FLORIDA

MANATEE COUNTY

1112 Manatee Avenue West  
Bradenton, FL 34205

WSP PROJECT NO:  
600865X4

90% FOR PERMITTING

REVISIONS			
NO.	DATE	BY	APPROVED

DESIGNED BY: ---  
DRAWN BY: ---  
CHECKED BY: ---  
APPROVED BY: ---  
DATE: 9/9/24

SHEET TITLE:  
  
DESIGN DETAILS 2  
OF 2

SHEET NUMBER:	REV. #
C-502	-
SHEET 1 OF - SHEETS	

**DEPARTMENT OF THE ARMY PERMIT TRANSFER REQUEST**

**DA PERMIT NUMBER: SAJ-2024-00265 (NWP-RSS)**

When the structures or work authorized by this permit are still in existence at the time the property is transferred, the terms and conditions of this permit will continue to be binding on the new owner(s) of the property. Although the construction period for works authorized by Department of the Army permits is finite, the permit itself, with its limitations, does not expire.

To validate the transfer of this permit and the associated responsibilities associated with compliance with its terms and conditions, have the transferee sign and date below and mail to the U.S. Army Corps of Engineers, Enforcement Section, Post Office Box 4970, Jacksonville, FL 32232-0019 or submit via electronic mail to: [SAJ-RD-Enforcement@usace.army.mil](mailto:SAJ-RD-Enforcement@usace.army.mil) (not to exceed 15 MB).

\_\_\_\_\_  
**(TRANSFEREE-SIGNATURE)**

\_\_\_\_\_  
**(SUBDIVISION)**

\_\_\_\_\_  
**(DATE)**

\_\_\_\_\_  
**(LOT)**

\_\_\_\_\_  
**(BLOCK)**

\_\_\_\_\_  
**(NAME-PRINTED)**

\_\_\_\_\_  
**(STREET ADDRESS)**

\_\_\_\_\_  
**(MAILING ADDRESS)**

\_\_\_\_\_  
**(CITY, STATE, ZIP CODE)**



# FLORIDA DEPARTMENT OF Environmental Protection

**Ron DeSantis**  
Governor

**Alexis A. Lambert**  
Secretary

Southwest District  
13051 North Telecom Parkway #101  
Temple Terrace, Florida 33637-0926

8/8/2025

Manatee County Public Works Natural Resources Department  
% Charlie Hundsicker  
1022 26th Avenue East  
Bradenton, Florida 34208  
[charlie.hundsicker@mymanatee.gov](mailto:charlie.hundsicker@mymanatee.gov)

Dear Charlie Hundsicker:

Enclosed is the Environmental Resource Permit, DEP Project No. 41-0454413-002-EI, issued pursuant to Part IV of Chapter 373, Florida Statutes, and Title 62, Florida Administrative Code.

Appeal rights for you and for any affected third party are described in the text of the permit along with conditions that must be met when authorized activities are undertaken.

You, as the applicant, are responsible for all aspects of permit compliance. You should therefore review this permit document carefully to ensure compliance with the general conditions and specific conditions contained herein.

Please be aware of permit General Condition number 4, which states, "At least 48 hours prior to beginning the authorized activities, the permittee shall submit to the Agency a fully executed Form 62-330.350(1), "Construction Commencement Notice"."

If you have any questions about this document, please contact me at [Olivia.oreilly@floridadep.gov](mailto:Olivia.oreilly@floridadep.gov) or (813) 470-5788. Thank you for your participation in the permit process and in managing the natural resources of the State of Florida.

Sincerely,

*Olivia O'Reilly*

Olivia O'Reilly  
Engineering Specialist I  
Permitting and Waste Cleanup Program

cc: Olivia O'Reilly, Southwest District, [Olivia.oreilly@floridadep.gov](mailto:Olivia.oreilly@floridadep.gov)  
Shannon Herbon, Southwest District, [shannon.herbon@floridadep.gov](mailto:shannon.herbon@floridadep.gov)  
ERP Permitting, Southwest District, [sw\\_erp@floridadep.gov](mailto:sw_erp@floridadep.gov)  
U.S. Army Corps of Engineers, [tampareg@usace.army.mil](mailto:tampareg@usace.army.mil)  
Sherri Swanson, Co-Applicant, [sherri.swanson@mymanatee.org](mailto:sherri.swanson@mymanatee.org)  
Gregory Corning, Consultant, [greg.corning@wsp.com](mailto:greg.corning@wsp.com)

Enclosure: Environmental Resource Permit with Attachments (41 pages)



# FLORIDA DEPARTMENT OF Environmental Protection

**Ron DeSantis**  
Governor

**Alexis A. Lambert**  
Secretary

Southwest District  
13051 North Telecom Parkway #101  
Temple Terrace, Florida 33637-0926

## **Permittee/Authorized Entity:**

Manatee County Public Works Natural Resources Department  
% Charlie Hundsicker  
1022 26th Avenue East  
Bradenton, Florida 34208

## **Bishop Point Living Shoreline**

### **Authorized Agent:**

WSP USA  
% Gregory Corning  
5411 SkyCenter Drive, Suite 659  
Tampa, Florida 33607

## **Individual Environmental Resource Permit**

### **State-owned Submerged Lands Authorization – Granted**

### **U.S. Army Corps of Engineers Authorization – Separate Corps Authorization Required**

Manatee County  
Permit No.: 41-0454413-002-EI

**Permit Issuance Date: 8/8/2025**  
**Permit Construction Phase Expiration Date: 8/7/2030**





# FLORIDA DEPARTMENT OF Environmental Protection

**Ron DeSantis**  
Governor

**Alexis A. Lambert**  
Secretary

Southwest District  
13051 North Telecom Parkway #101  
Temple Terrace, Florida 33637-0926

## Consolidated Environmental Resource Permit and Sovereignty Submerged Lands Authorization

**Permittee: Charlie Hundsicker**  
**Permit No: 41-0454413-002-EI**

### PROJECT LOCATION

The activities authorized by this permit are located at 2020 72nd Street Northwest Bradenton, Florida 34209, in Section 19, Township 34 South, Range 17 East, in Manatee County, at latitude 27.51961253 / longitude -82.63336874.

### PROJECT DESCRIPTION

The permittee is authorized to construct a living shoreline on an existing peninsula within Warners Bayou, a Class III, Florida Waterbody. These activities include the removal of an existing approximately 380-linear-foot seawall, approximately 25 5-inch by 5-inch posts, approximately 21 concrete filled PVC bollards, and approximately 24-linear-feet of reinforced concrete pipe. On the eastern side of the peninsula, approximately 1,026 square feet of riprap will be installed at a 4:1 slope, while the western side will feature 42 reef balls placed at 5-foot intervals. A 174-linear-foot, 5-foot-wide permeable paver walkway will be constructed in the uplands, extending to the Mean High-Water Line (MHWL), positioned between the riprap and reef ball areas. Adjacent to the walkway, a 198-linear-foot, 4-foot-wide bioswale will be constructed, beginning in the uplands, passing under the walkway at one point, and continuing to the MHWL. Approximately 388 square yards of native vegetation will be planted along the shoreline, adjacent to both the riprap and reef ball installations. Additionally, two staggered rows of reef balls, containing a total of 26 units, will be placed to the north of the living shoreline area. Authorized activities are depicted on the attached exhibits.

The permittee shall utilize a floating turbidity curtain and silt fence throughout the construction process. Soil tracking prevention devices will be used, and construction activities will be conducted in a manner to avoid harming existing vegetation and wildlife.

### AUTHORIZATIONS

#### **Bishop Point Living Shoreline**

#### Environmental Resource Permit

Permittee: Charlie Hundsicker  
 Permit No.: 41-0454413-002-EI  
 Page 3 of 19

Permit Expiration: 8/7/2030

The Department has determined that the activity qualifies for an Environmental Resource Permit. Therefore, the Environmental Resource Permit is hereby granted, pursuant to Part IV of Chapter 373, Florida Statutes (F.S.), and Chapter 62-330, Florida Administrative Code (F.A.C.).

#### Sovereignty Submerged Lands Authorization

The activity is located on sovereignty submerged lands owned by the State of Florida. It therefore also requires authorization from the Board of Trustees of the Internal Improvement Trust Fund (Board of Trustees), pursuant to Article X, Section 11 of the Florida Constitution, and Section 253.77, F.S. As staff to the Board of Trustees of the Internal Improvement Trust Fund (Board of Trustees) under Sections 253.002, F.S., the Department has determined that the activity qualifies for and requires a Letter of Consent, as long as the work performed is located within the boundaries as described and is consistent with the terms and conditions herein.

During the term of this Letter of Consent you shall maintain satisfactory evidence of sufficient upland interest as required by paragraph 18-21.004(3)(b), Florida Administrative Code. If such interest is terminated or the Board of Trustees determines that such interest did not exist on the date of issuance of this Letter of Consent, this Letter of Consent may be terminated by the Board of Trustees at its sole option. If the Board of Trustees terminates this Letter of Consent, you agree not to assert a claim or defense against the Board of Trustees arising out of this Letter of Consent.

#### Federal Authorization

Your proposed activity as outlined on your application and attached drawings **does not qualify** for Federal authorization pursuant to the State Programmatic General Permit and a **SEPARATE permit** or authorization **shall be required** from the Corps. You must apply separately to the Corps using the Application for Department of the Army Permit (ENG 4345) or alternative as allowed by Corps regulations. More information on Corps permitting may be found online in the Jacksonville District Regulatory Division Sourcebook:

(<https://www.saj.usace.army.mil/Missions/Regulatory/Source-Book/>).

Authority for review - an agreement with the USACOE entitled "Coordination Agreement Between the U. S. Army Corps of Engineers (Jacksonville District) and the Florida Department of Environmental Protection (or Duly Authorized Designee), State Programmatic General Permit", Section 10 of the Rivers and Harbor Act of 1899, and Section 404 of the Clean Water Act.

#### Coastal Zone Management Consistent

Issuance of this authorization also constitutes a finding of consistency with Florida's Coastal Zone Management Program, as required by Section 307 of the Coastal Zone Management Act.

#### Water Quality Certification Granted

This permit also constitutes a *grant* of water quality certification under Section 401 of the Clean Water Act, 33 U.S.C. Section 1341. Pursuant to Rule 62-330.062, F.A.C. issuance of the individual or conceptual approval permit under this chapter shall constitute certification of compliance with water quality standards.

#### Other Authorizations

You are advised that authorizations or permits for this activity may be required by other federal, state, regional, or local entities including but not limited to local governments or municipalities.

Permittee: Charlie Hundsicker  
 Permit No.: 41-0454413-002-EI  
 Page 4 of 19

Permit Expiration: 8/7/2030

This permit does not relieve you from the requirements to obtain all other required permits or authorizations.

The activity described may be conducted only in accordance with the terms, conditions and attachments contained in this document. Issuance and granting of the permit and authorizations herein do not infer, nor guarantee, nor imply that future permits, authorizations, or modifications will be granted by the Department.

## **PERMIT/SOVEREIGNTY SUBMERGED LANDS CONDITIONS**

The activities described must be conducted in accordance with:

- **The Specific Conditions**
- **The General Conditions**
- **The Special Consent Conditions**
- **The General Conditions for Sovereignty Submerged Lands Authorization**
- **The limits, conditions and locations of work shown in the attached drawings**
- **The term limits of this authorization**

You are advised to read and understand these conditions and drawings prior to beginning the authorized activities, and to ensure the work is conducted in conformance with all the terms, conditions, and drawings herein. If you are using a contractor, the contractor also should read and understand these conditions and drawings prior to beginning any activity. Failure to comply with these conditions, including any mitigation requirements, shall be grounds for the Department to revoke the permit and authorization and to take appropriate enforcement action. Operation of the facility is not authorized except when determined to be in conformance with all applicable rules and this permit and sovereignty submerged lands authorization, as described.

## **SPECIFIC CONDITIONS**

1. Submittals required herein (e.g., progress reports, as-built drawings, etc.) shall include the permittee's name and permit number 41-0454413-002-EI and shall be directed by e-mail to [SW\\_ERP\\_CAP@floridadep.gov](mailto:SW_ERP_CAP@floridadep.gov) with a subject line of "Compliance: permit number 41-0454413-002-EI", or by mail to:

Department of Environmental Protection  
 Southwest District  
 ATTN: ERP Compliance Assurance  
 13051 North Telecom Parkway, Suite 101  
 Temple Terrace, FL 33637-0926

2. The structure/work authorized by this permit shall not be placed/conducted on any property, other than that owned by the permittee, without the prior written approval of that property owner.

3. In the event the permittee files for bankruptcy prior to completion of work permitted and required by this permit, the permittee must notify the Department within 30 days of filing. The notification shall identify the bankruptcy court and case number and shall include a copy of the bankruptcy petition.

#### **SPECIFIC CONDITIONS – PRIOR TO ANY CONSTRUCTION**

4. Best management practices for erosion control shall be implemented prior to construction commencement and shall be maintained at all times during construction to prevent siltation and turbid discharges in excess of State water quality standards (>29 NTU's above background, pursuant to Rule 62-302, F.A.C. Methods may include, but are not limited to the use of staked hay bales, staked filter cloth, sodding, seeding, staged construction and the installation of turbidity screens around the immediate project site.

#### **SPECIFIC CONDITIONS – CONSTRUCTION ACTIVITIES**

5. Wetland areas or waterbodies that are outside the specific limits of construction authorized by this permit, must be protected from erosion, sedimentation, siltation, scouring, excess turbidity, and/or dewatering. There shall be no discharge in violation of the water quality standards in Chapter 62-302, F.A.C. Turbidity/erosion controls shall be installed prior to clearing, excavation or placement of fill material, shall be maintained until construction is completed, disturbed areas are stabilized, and turbidity levels have fallen to less than 29 NTU's above background ambient background. The turbidity and erosion control devices shall be removed within 14 days once these conditions are met.
6. Areas of exposed soils shall be isolated from wetlands or other surface waters to prevent erosion and deposition of these soils into wetlands or other surface waters during construction and operation of permitted activities.
7. The permittee shall be responsible for ensuring erosion control devices/procedures are inspected and maintained daily during all phases of construction authorized by this permit until areas disturbed during construction are sufficiently stabilized to prevent erosion, siltation, and turbid discharges.
8. A floating turbidity apron/curtain shall be installed around the waterward boundary of the construction area prior to construction and shall remain in place until construction is complete and turbidity levels within the work area have returned to background levels. The curtain will be kept outside of the seagrass beds as shown on Sheet C-104 to prevent the curtains from causing damage to the adjacent beds.
9. Floating turbidity curtains with weighted skirts shall be placed around the peninsula prior to the initiation of work authorized by this permit. The screens shall be maintained and remain in place for the duration of the construction to ensure turbidity levels outside the construction area do not violate state water quality standards (>29 NTU's over background). The permittee shall be responsible for inspecting and maintaining turbidity control devices so turbidity does not violate state water quality standards (>29 NTU's over background) outside of the turbidity screens.

10. The following measures shall be taken immediately by the permittee when turbidity levels within waters of the State surrounding the project site violate state water quality standards:
  - a. Immediately cease work contributing to the water quality violation.
  - b. Stabilize exposed soils contributing to the violation. Modify the work procedures responsible for the violation, install additional turbidity containment devices and repair non-functioning turbidity containment devices.
  - c. Notify the Department within 24 hours of the time the violation is first detected.
11. The riprap shall be constructed in accordance with the specifications per Sheet C-302 of the attached permit drawings and shall have a minimum waterward face slope of 3:1 (horizontal/vertical).
12. The riprap revetment shall be constructed in accordance with the distances from fixed landmarks as shown on Sheet C-103 the attached permit drawings.
13. "Riprap" shall consist of unconsolidated boulders, rocks, or clean concrete rubble with no exposed reinforcing rods or similar protrusions. The riprap shall be free of sediment, debris and toxins or otherwise deleterious substances, and shall have average dimensions of one to three feet in diameter.
14. The riprap revetment shall be fully constructed as shown on Sheet C-103 of the attached permit drawings prior to the placement of backfill material. Fill material used behind the riprap revetment shall be clean fill and free of vegetative matter, trash, garbage, toxic or hazardous waste or other unsuitable materials.
15. The permittee shall report any damage to wetlands/littoral zone area as a result of the riprap construction to the Department within 24 hours.
16. The seawall shall be fully constructed prior to the placement of any backfill material. Any fill material used behind the seawall shall be clean fill and free of vegetative matter, trash, garbage, toxic or hazardous waste or any other unsuitable materials.
17. Dredging within waters of the State for the purpose of providing backfill is specifically prohibited.
18. Watercraft associated with the construction of the permitted structure shall operate within waters of sufficient depth to preclude bottom scouring/prop dredging. There shall be a minimum 12-inch clearance between the deepest draft of the vessel (with the motor in the down position) and the top of submerged resources as measured at mean low water.
19. This permit does not authorize the installation of water, sewer, cable or utility lines within wetlands or waterbodies.

Permittee: Charlie Hundsicker  
Permit No.: 41-0454413-002-EI  
Page 7 of 19

Permit Expiration: 8/7/2030

20. Unauthorized impacts to wetlands or shoreline as a result of the authorized construction shall be reported to the Department within 24 hours.
21. Storage or stockpiling of tools and materials (i.e., lumber, pilings, debris) within wetlands or other surface waters is prohibited.

### **SPECIFIC MANATEE CONDITIONS**

22. All personnel associated with the project shall be instructed about the presence of manatees and manatee speed zones, and the need to avoid collisions with, and injury to manatees. The permittee shall advise all construction personnel that there are civil and criminal penalties for harming, harassing, or killing manatees which are protected under the Marine Mammal Protection Act, the Endangered Species Act, and the Florida Manatee Sanctuary Act.
23. All vessels associated with the construction project shall operate at "Idle Speed/No Wake" at all times while in the immediate area and while in water where the draft of the vessel provides less than a four-foot clearance from the bottom. All vessels shall follow routes of deep water whenever possible.
24. Siltation or turbidity barriers shall be made of material in which manatees cannot become entangled, shall be properly secured, and shall be regularly monitored to avoid manatee entanglement or entrapment. Barriers shall not impede manatee movement.
25. All on-site project personnel are responsible for observing water-related activities for the presence of manatees. All in-water operations, including vessels, shall be shutdown if a manatee comes within 50 feet of the operation. Activities shall not resume until every manatee has moved beyond the 50-foot radius of the project operation, or until 30 minutes has elapsed wherein a manatee has not reappeared within 50 feet of the operation. Animals shall not be herded away or harassed into leaving.
26. Any collision with or injury to a manatee shall be reported immediately to the FWC Hotline at 1-888-404-FWCC. Collision and/or injury should also be reported to the U.S. Fish and Wildlife Service in Jacksonville (1-904-731-3336) for north Florida or Vero Beach (1-772-562-3909) for south Florida.
27. Temporary signs concerning manatees shall be posted prior to and during all in-water project activities. All signs are to be removed by the permittee upon completion of the project. Awareness signs that have already been approved for this use by the Florida Fish and Wildlife Conservation Commission (FWC) must be used. One sign measuring at least 3 ft. by 4 ft. which reads *Caution: Manatee Area* must be posted. A second sign measuring at least 8 1/2" by 11" explaining the requirements for "Idle Speed/No Wake" and the shutdown of in-water operations must be posted in a location prominently visible to all personnel engaged in water-related activities. Please see the Florida Fish and Wildlife Conservation Commission website for information on how to obtain appropriate signs: [http://www.myfwc.com/docs/WildlifeHabitats/Manatee\\_EducationalSign.pdf](http://www.myfwc.com/docs/WildlifeHabitats/Manatee_EducationalSign.pdf)

## SPECIFIC CONDITIONS FOR LISTED SPECIES

28. This permit does not authorize the permittee to cause any adverse impact to or “take” of state listed species and other regulated species of fish and wildlife. Compliance with state laws regulating the take of fish and wildlife is the responsibility of the owner or permittee associated with this project. Please refer to Chapter 68A-27 of the Florida Administrative Code for definitions of “take” and a list of fish and wildlife species. If listed species are observed onsite, Florida Fish and Wildlife Conservation Commission (FWC) staff are available to provide decision support information or assist in obtaining the appropriate FWC permits. Most marine endangered and threatened species are statutorily protected and a “take” permit cannot be issued. Requests for further information or review can be sent to [ConservationPlanningServices@MyFWC.com](mailto:ConservationPlanningServices@MyFWC.com).
29. If new information (e.g. listing of new species, new critical habitat, etc.) shows that the magnitude of impacts to federally listed species has the potential for adverse effects, the U.S. Fish and Wildlife Service (USFWS) will notify the Department. The Department will initiate coordination with the permittee and with the USFWS to determine what adverse impacts are likely and if additional minimization measures, reporting, or monitoring are required in order to be consistent with the Endangered Species Act, as deemed necessary by USFWS.
30. The Permittee shall report any injured, sick, or dead federally or state listed animal(s) discovered onsite to the Florida Fish and Wildlife Conservation Commission Wildlife Alert number at 888-404-FWCC (3922).

## SPECIFIC CONDITIONS – CONSTRUCTION COMPLETION

The permittee shall comply with the following conditions prior to the transfer to operation phase of the facility. All documentation required below shall be included with the permittee’s request to transfer the project to the operation phase [Form No. 62-330.310(2), F.A.C.].

31. Within 30 days after completion of construction of the permitted or authorized activity, and prior to transfer to operation, the permittee shall submit photographs of the completed structure. The photographs shall show the size and dimensions of all existing structures and activities within the permitted project area. Constructed deviations may require a permit modification and/or easement.
32. The permittee shall submit one set of signed, dated and sealed as-built drawings to the Department via email at [SW\\_ERP\\_CAP@dep.state.fl.us](mailto:SW_ERP_CAP@dep.state.fl.us) for review and approval within 30 days of completion of construction. (Please contact the Department for files that are too large to email for alternative means of submitting electronically.) The as-built drawings shall be based on the Department permitted construction drawings and any pertinent specific conditions, which should be revised to reflect changes made during construction. Both the original design and constructed elevations must be clearly shown. The plans must be clearly labeled as "as-built" or "record" drawings. Surveyed dimensions and elevations required shall be verified and signed, dated and sealed by a Florida registered professional. *As-builts shall be submitted to the Department regardless*

Permittee: Charlie Hundsicker  
 Permit No.: 41-0454413-002-EI  
 Page 9 of 19

Permit Expiration: 8/7/2030

*of whether or not deviations are present. In addition, the permittee shall submit the "As-Built Certification and Request for Conversion to Operation Phase" form (Ch. 62-330.310(1), F.A.C.); as required in General Condition #6.*

The following information shall be verified on the as-built drawings from the engineering drawings signed and sealed by Gregory W. Corning, #79293, on 8/07/2025:

Plan View/ Cross Section Name	Drawing Number
Proposed Site Plan	C-103
Erosion and Sediment Controls Plan	C-104
Planting Plan	C-105
Cross Section 1 of 2	C-301
Cross Section 2 of 2	C-302

### **SPECIFIC CONDITIONS – OPERATION AND MAINTENANCE ACTIVITIES**

33. All ditches and swales from the point at which they receive runoff from the project area and through their entire downstream length shall be well maintained and stabilized to ensure that they are not subject to erosion.
34. All vegetative plantings will be monitored immediately after construction completion until the plantings are established, pruned and replanted as needed. After that point, periodic inspections will take place to track the condition of the area.

### **GENERAL CONDITIONS FOR INDIVIDUAL PERMITS**

The following general conditions are binding on all individual permits issued under this chapter, except where the conditions are not applicable to the authorized activity, or where the conditions must be modified to accommodate project-specific conditions.

1. All activities shall be implemented following the plans, specifications and performance criteria approved by this permit. Any deviations must be authorized in a permit modification in accordance with Rule 62-330.315, F.A.C. Any deviations that are not so authorized may subject the permittee to enforcement action and revocation of the permit under Chapter 373, F.S.
2. A complete copy of this permit shall be kept at the work site of the permitted activity during the construction phase, and shall be available for review at the work site upon request by the Agency staff. The permittee shall require the contractor to review the complete permit prior to beginning construction.
3. Activities shall be conducted in a manner that does not cause or contribute to violations of state water quality standards. Performance-based erosion and sediment control best management practices shall be installed immediately prior to, and be maintained during and after construction as needed, to prevent adverse impacts to the water resources and adjacent lands. Such practices shall be in accordance with the *State of Florida Erosion and Sediment*



*Control Designer and Reviewer Manual (Florida Department of Environmental Protection and Florida Department of Transportation June 2007), and the Florida Stormwater Erosion and Sedimentation Control Inspector's Manual (Florida Department of Environmental Protection, Nonpoint Source Management Section, Tallahassee, Florida, July 2008), which are both incorporated by reference in subparagraph 62-330.050(9)(b)5., F.A.C., unless a project-specific erosion and sediment control plan is approved or other water quality control measures are required as part of the permit.*

4. At least 48 hours prior to beginning the authorized activities, the permittee shall submit to the Agency a fully executed Form 62-330.350(1), "Construction Commencement Notice," (October 1, 2013), (<http://www.flrules.org/Gateway/reference.asp?No=Ref-02505>), incorporated by reference herein, indicating the expected start and completion dates. A copy of this form may be obtained from the Agency, as described in subsection 62-330.010(5), F.A.C., and shall be submitted electronically or by mail to the Agency. However, for activities involving more than one acre of construction that also require a NPDES stormwater construction general permit, submittal of the Notice of Intent to Use Generic Permit for Stormwater Discharge from Large and Small Construction Activities, DEP Form 62-621.300(4)(b), shall also serve as notice of commencement of construction under this chapter and, in such a case, submittal of Form 62-330.350(1) is not required.
5. Unless the permit is transferred under Rule 62-330.340, F.A.C., or transferred to an operating entity under Rule 62-330.310, F.A.C., the permittee is liable to comply with the plans, terms and conditions of the permit for the life of the project or activity.
6. Within 30 days after completing construction of the entire project, or any independent portion of the project, the permittee shall provide the following to the Agency, as applicable:
  - a. For an individual, private single-family residential dwelling unit, duplex, triplex, or quadruplex – "Construction Completion and Inspection Certification for Activities Associated With a Private Single-Family Dwelling Unit" [Form 62-330.310(3)]; or
  - b. For all other activities – "As-Built Certification and Request for Conversion to Operational Phase" [Form 62-330.310(1)].
  - c. If available, an Agency website that fulfills this certification requirement may be used in lieu of the form.
7. If the final operation and maintenance entity is a third party:
  - a. Prior to sales of any lot or unit served by the activity and within one year of permit issuance, or within 30 days of as-built certification, whichever comes first, the permittee shall submit, as applicable, a copy of the operation and maintenance documents (see sections 12.3 thru 12.3.3 of Volume I) as filed with the Department of State, Division of Corporations and a copy of any easement, plat, or deed restriction needed to operate or maintain the project, as recorded with the Clerk of the Court in the County in which the activity is located.

- b. Within 30 days of submittal of the as- built certification, the permittee shall submit “Request for Transfer of Environmental Resource Permit to the Perpetual Operation Entity” [Form 62-330.310(2)] to transfer the permit to the operation and maintenance entity, along with the documentation requested in the form. If available, an Agency website that fulfills this transfer requirement may be used in lieu of the form.
8. The permittee shall notify the Agency in writing of changes required by any other regulatory agency that require changes to the permitted activity, and any required modification of this permit must be obtained prior to implementing the changes.
9. This permit does not:
  - a. Convey to the permittee any property rights or privileges, or any other rights or privileges other than those specified herein or in Chapter 62-330, F.A.C.;
  - b. Convey to the permittee or create in the permittee any interest in real property;
  - c. Relieve the permittee from the need to obtain and comply with any other required federal, state, and local authorization, law, rule, or ordinance; or
  - d. Authorize any entrance upon or work on property that is not owned, held in easement, or controlled by the permittee.
10. Prior to conducting any activities on state-owned submerged lands or other lands of the state, title to which is vested in the Board of Trustees of the Internal Improvement Trust Fund, the permittee must receive all necessary approvals and authorizations under Chapters 253 and 258, F.S. Written authorization that requires formal execution by the Board of Trustees of the Internal Improvement Trust Fund shall not be considered received until it has been fully executed.
11. The permittee shall hold and save the Agency harmless from any and all damages, claims, or liabilities that may arise by reason of the construction, alteration, operation, maintenance, removal, abandonment or use of any project authorized by the permit.
12. The permittee shall notify the Agency in writing:
  - a. Immediately if any previously submitted information is discovered to be inaccurate; and
  - b. Within 30 days of any conveyance or division of ownership or control of the property or the system, other than conveyance via a long-term lease, and the new owner shall request transfer of the permit in accordance with Rule 62-330.340, F.A.C. This does not apply to the sale of lots or units in residential or commercial subdivisions or condominiums where the stormwater management system has been completed and converted to the operation phase.

13. Upon reasonable notice to the permittee, Agency staff with proper identification shall have permission to enter, inspect, sample and test the project or activities to ensure conformity with the plans and specifications authorized in the permit.
14. If prehistoric or historic artifacts, such as pottery or ceramics, projectile points, stone tools, dugout canoes, metal implements, historic building materials, or any other physical remains that could be associated with Native American, early European, or American settlement are encountered at any time within the project site area, the permitted project shall cease all activities involving subsurface disturbance in the vicinity of the discovery. The permittee or other designee shall contact the Florida Department of State, Division of Historical Resources, Compliance Review Section (DHR), at (850)245-6333, as well as the appropriate permitting agency office. Project activities shall not resume without verbal or written authorization from the Division of Historical Resources. If unmarked human remains are encountered, all work shall stop immediately and the proper authorities notified in accordance with section 872.05, F.S. For project activities subject to prior consultation with the DHR and as an alternative to the above requirements, the permittee may follow procedures for unanticipated discoveries as set forth within a cultural resources assessment survey determined complete and sufficient by DHR and included as a specific permit condition herein.
15. Any delineation of the extent of a wetland or other surface water submitted as part of the permit application, including plans or other supporting documentation, shall not be considered binding unless a specific condition of this permit or a formal determination under Rule 62-330.201, F.A.C., provides otherwise.
16. The permittee shall provide routine maintenance of all components of the stormwater management system to remove trapped sediments and debris. Removed materials shall be disposed of in a landfill or other uplands in a manner that does not require a permit under Chapter 62-330, F.A.C., or cause violations of state water quality standards.
17. This permit is issued based on the applicant's submitted information that reasonably demonstrates that adverse water resource-related impacts will not be caused by the completed permit activity. If any adverse impacts result, the Agency will require the permittee to eliminate the cause, obtain any necessary permit modification, and take any necessary corrective actions to resolve the adverse impacts.
18. A Recorded Notice of Environmental Resource Permit may be recorded in the county public records in accordance with subsection 62-330.090(7), F.A.C. Such notice is not an encumbrance upon the property.
19. In addition to those general conditions in subsection (1), above, the Agency shall impose any additional project-specific special conditions necessary to assure the permitted activities will not be harmful to the water resources, as set forth in rules 62-330.301 and 62-330.302, F.A.C., Volumes I and II, as applicable, and the rules incorporated by reference in this chapter.

## **SPECIAL CONSENT CONDITIONS**

1. The applicant agrees to indemnify, defend and hold harmless the Board of Trustees and the State of Florida from all claims, actions, lawsuits and demands in any form arising out of the authorization to use sovereignty submerged lands or the applicant's use and construction of structures on sovereignty submerged lands. This duty to indemnify and hold harmless will include any and all liabilities that are associated with the structure or activity including special assessments or taxes that are now or in the future assessed against the structure or activity during the period of the authorization.
2. Failure by the Board of Trustees to enforce any violation of a provision of the authorization or waiver by the Board of Trustees of any provision of the authorization will not invalidate the provision not enforced or waived, nor will the failure to enforce or a waiver prevent the Board of Trustees from enforcing the unenforced or waived provision in the event of a violation of that provision.
3. Applicant binds itself and its successors and assigns to abide by the provisions and conditions set forth in the authorization. If the applicant or its successors or assigns fails or refuses to comply with the provisions and conditions of the authorization, the authorization may be terminated by the Board of Trustees after written notice to the applicant or its successors or assigns. Upon receipt of such notice, the applicant or its successors or assigns will have thirty (30) days in which to correct the violations. Failure to correct the violations within this period will result in the automatic revocation of this authorization.
4. All costs incurred by the Board of Trustees in enforcing the terms and conditions of the authorization will be paid by the applicant. Any notice required by law will be made by certified mail at the address shown on page one of the authorization. The applicant will notify the Board of Trustees in writing of any change of address at least ten days before the change becomes effective.
5. This authorization does not allow any activity prohibited in a conservation easement or restrictive covenant that prohibits the activity.

#### **GENERAL CONDITIONS FOR SOVEREIGNTY SUBMERGED LANDS AUTHORIZATION**

Any use of sovereignty submerged lands is subject to the following general conditions are binding upon the applicant and are enforceable under Chapter 253, F.S.

1. Sovereignty submerged lands may be used only for the specified activity or use. Any unauthorized deviation from the specified activity or use and the conditions for undertaking that activity or use will constitute a violation. Violation of the authorization will result in suspension or revocation of the applicant's use of the sovereignty submerged lands unless cured to the satisfaction of the Board of Trustees.
2. Authorization under Rule 18-21.005, F.A.C., conveys no title to sovereignty submerged lands or water column, nor does it constitute recognition or acknowledgment of any other person's title to such land or water.

3. Authorizations under Rule 18-21.005, F.A.C., may be modified, suspended or revoked in accordance with its terms or the remedies provided in Sections 253.04, F.S. and Chapter 18-14, F.A.C.
4. Structures or activities will be constructed and used to avoid or minimize adverse impacts to resources.
5. Construction, use, or operation of the structure or activity will not adversely affect any species which is endangered, threatened or of special concern, as listed in Rules 68A-27.003, 68A-27.004, and 68A-27.005, F.A.C.
6. Structures or activities will not unreasonably interfere with riparian rights. When a court of competent jurisdiction determines that riparian rights have been unlawfully affected, the structure or activity will be modified in accordance with the court's decision.
7. Structures or activities will not create a navigational hazard.
8. Activities shall not interfere with the public easement for traditional uses of the sandy beaches provided in section 161.141, F.S.
9. Structures will be maintained in a functional condition and will be repaired or removed if they become dilapidated to such an extent that they are no longer functional. This shall not be construed to prohibit the repair or replacement subject to the provisions of rule 18-21.005, F.A.C., within one year, of a structure damaged in a discrete event such as a storm, flood, accident, or fire.
10. Structures or activities will be constructed, operated, and maintained solely for water dependent purposes, or for non-water dependent activities authorized under paragraph 18-21.004(1)(g), F.A.C., or any other applicable law.
11. The applicant agrees to indemnify, defend and hold harmless the Board of Trustees and the State of Florida from all claims, actions, lawsuits and demands in any form arising out of the authorization to use sovereignty submerged lands or the applicant's use and construction of structures on sovereignty submerged lands. This duty to indemnify and hold harmless will include any and all liabilities that are associated with the structure or activity including special assessments or taxes that are now or in the future assessed against the structure or activity during the period of the authorization.
12. Failure by the Board of Trustees to enforce any violation of a provision of the authorization or waiver by the Board of Trustees of any provision of the authorization will not invalidate the provision not enforced or waived, nor will the failure to enforce or a waiver prevent the Board of Trustees from enforcing the unenforced or waived provision in the event of a violation of that provision.
13. Applicant binds itself and its successors and assigns to abide by the provisions and conditions set forth in the authorization. If the applicant or its successors or assigns fails or

refuses to comply with the provisions and conditions of the authorization, the authorization may be terminated by the Board of Trustees after written notice to the applicant or its successors or assigns. Upon receipt of such notice, the applicant or its successors or assigns will have thirty (30) days in which to correct the violations. Failure to correct the violations within this period will result in the automatic revocation of this authorization.

14. All costs incurred by the Board of Trustees in enforcing the terms and conditions of the authorization will be paid by the applicant. Any notice required by law will be made by certified mail at the address shown on page one of the authorization. The applicant will notify the Board of Trustees in writing of any change of address at least ten days before the change becomes effective.
15. This authorization does not allow any activity prohibited in a conservation easement or restrictive covenant that prohibits the activity.

## NOTICE OF RIGHTS

This action is final and effective on the date filed with the Clerk of the Department unless a petition for an administrative hearing is timely filed under Sections 120.569 and 120.57, F.S., before the deadline for filing a petition. On the filing of a timely and sufficient petition, this action will not be final and effective until further order of the Department. Because the administrative hearing process is designed to formulate final agency action, the hearing process may result in a modification of the agency action or even denial of the application.

### Petition for Administrative Hearing

A person whose substantial interests are affected by the Department's action may petition for an administrative proceeding (hearing) under Sections 120.569 and 120.57, F.S. Pursuant to Rule 28-106.20 and 28-106.301, F.A.C., a petition for an administrative hearing must contain the following information:

- (a) The name and address of each agency affected and each agency's file or identification number, if known;
- (b) The name, address, any e-mail address, any facsimile number, and telephone number of the petitioner, if the petitioner is not represented by an attorney or a qualified representative; the name, address, and telephone number of the petitioner's representative, if any, which shall be the address for service purposes during the course of the proceeding; and an explanation of how the petitioner's substantial interests will be affected by the agency determination;
- (c) A statement of when and how the petitioner received notice of the agency decision;
- (d) A statement of all disputed issues of material fact. If there are none, the petition must so indicate;
- (e) A concise statement of the ultimate facts alleged, including the specific facts that the petitioner contends warrant reversal or modification of the agency's proposed action;
- (f) A statement of the specific rules or statutes that the petitioner contends require reversal or modification of the agency's proposed action, including an explanation of how the alleged facts relate to the specific rules or statutes; and

Permittee: Charlie Hundsicker  
Permit No.: 41-0454413-002-EI  
Page 16 of 19

Permit Expiration: 8/7/2030

- (g) A statement of the relief sought by the petitioner, stating precisely the action that the petitioner wishes the agency to take with respect to the agency's proposed action.

The petition must be filed (received by the Clerk) in the Office of General Counsel of the Department at 3900 Commonwealth Boulevard, Mail Station 35, Tallahassee, Florida 32399-3000, or via electronic correspondence at [Agency\\_Clerk@dep.state.fl.us](mailto:Agency_Clerk@dep.state.fl.us). Also, a copy of the petition shall be mailed to the applicant at the address indicated above at the time of filing.

#### Time Period for Filing a Petition

In accordance with Rule 62-110.106(3), F.A.C., petitions for an administrative hearing by the applicant and persons entitled to written notice under Section 120.60(3), F.S., must be filed within 21 days of receipt of this written notice. Petitions filed by any persons other than the applicant, and other than those entitled to written notice under Section 120.60(3), F.S., must be filed within 21 days of publication of the notice or within 21 days of receipt of the written notice, whichever occurs first. You cannot justifiably rely on the finality of this decision unless notice of this decision and the right of substantially affected persons to challenge this decision has been duly published or otherwise provided to all persons substantially affected by the decision. While you are not required to publish notice of this action, you may elect to do so pursuant Rule 62-110.106(10)(a).

The failure to file a petition within the appropriate time period shall constitute a waiver of that person's right to request an administrative determination (hearing) under [Sections 120.569](#) and [120.57](#), F.S., or to intervene in this proceeding and participate as a party to it. Any subsequent intervention (in a proceeding initiated by another party) will be only at the discretion of the presiding officer upon the filing of a motion in compliance with Rule 28-106.205, F.A.C. If you do not publish notice of this action, this waiver will not apply to persons who have not received written notice of this action.

#### Extension of Time

Under Rule 62-110.106(4), F.A.C., a person whose substantial interests are affected by the Department's action may also request an extension of time to file a petition for an administrative hearing. The Department may, for good cause shown, grant the request for an extension of time. Requests for extension of time must be filed with the Office of General Counsel of the Department at 3900 Commonwealth Boulevard, Mail Station 35, Tallahassee, Florida 32399-3000, or via electronic correspondence at [Agency\\_Clerk@dep.state.fl.us](mailto:Agency_Clerk@dep.state.fl.us), before the deadline for filing a petition for an administrative hearing. A timely request for extension of time shall toll the running of the time period for filing a petition until the request is acted upon.

#### Mediation

Mediation is not available in this proceeding.

#### FLAWAC Review

The applicant, or any party within the meaning of Section 373.114(1)(a) or 373.4275, F.S., may also seek appellate review of this order before the Land and Water Adjudicatory Commission under Section 373.114(1) or 373.4275, F.S. Requests for review before the Land and Water Adjudicatory Commission must be filed with the Secretary of the Commission and served on the Department within 20 days from the date when this order is filed with the Clerk of the Department.

Permittee: Charlie Hundsicker  
Permit No.: 41-0454413-002-EI  
Page 17 of 19

Permit Expiration: 8/7/2030

### Judicial Review

Once this decision becomes final, any party to this action has the right to seek judicial review pursuant to Section 120.68, F.S., by filing a Notice of Appeal pursuant to Florida Rules of Appellate Procedure 9.110 and 9.190 with the Clerk of the Department in the Office of General Counsel (Station #35, 3900 Commonwealth Boulevard, Tallahassee, Florida 32399-3000) and by filing a copy of the Notice of Appeal accompanied by the applicable filing fees with the appropriate district court of appeal. The notice must be filed within 30 days from the date this action is filed with the Clerk of the Department.



Permittee: Charlie Hundsicker  
 Permit No.: 41-0454413-002-EI  
 Page 18 of 19

Permit Expiration: 8/7/2030

Executed in Hillsborough County, Florida.

STATE OF FLORIDA DEPARTMENT  
 OF ENVIRONMENTAL PROTECTION



---

Sarah McWilliams  
 Environmental Manager  
 Permitting and Waste Cleanup Programs  
 Southwest District

**Attachments:**

Exhibit 1, Project Drawings and Design Specs., 12 pages  
 Standard Manatee Construction Conditions 2011, 2 Pages  
 Construction Commencement Notice/Form 62-330.350(1), 1 page  
 As-Built Certification and Request for Conversion to Operation Phase/Form 62-330.310(1), 3 pages  
 Operation and Maintenance Inspection Certification/Form 62-330.311(1), 2 pages  
 Request for Transfer of Permit to the Perpetual Operation Entity/Form 62-330.310(2), 1 page  
 Request to Transfer Permit/Form 62-330.340(1), 2 pages

**Copies furnished to:**

Olivia O'Reilly, Southwest District, [Olivia.oreilly@floridadep.gov](mailto:Olivia.oreilly@floridadep.gov)  
 Shannon Herbon, Southwest District, [shannon.herbon@floridadep.gov](mailto:shannon.herbon@floridadep.gov)  
 ERP Permitting, Southwest District, [sw\\_erp@floridadep.gov](mailto:sw_erp@floridadep.gov)  
 U.S. Army Corps of Engineers, [tampareg@usace.army.mil](mailto:tampareg@usace.army.mil)  
 Sherri Swanson, Co-Applicant, [sherri.swanson@mymanatee.org](mailto:sherri.swanson@mymanatee.org)  
 Gregory Corning, Consultant, [greg.corning@wsp.com](mailto:greg.corning@wsp.com)

CERTIFICATE OF SERVICE

The undersigned hereby certifies that this permit including all copies, were mailed before the close of business on **August 8, 2025**, to the above listed persons.

FILING AND ACKNOWLEDGMENT

FILED, on this date, under 120.52(7) of the  
 Florida Statutes, with the designated Department Clerk,

Permittee: Charlie Hundsicker  
Permit No.: 41-0454413-002-EI  
Page 19 of 19

Permit Expiration: 8/7/2030

receipt of which is hereby acknowledged.

  
Clerk

August 8, 2025  
Date

## STANDARD MANATEE CONDITIONS FOR IN-WATER WORK 2011

The permittee shall comply with the following conditions intended to protect manatees from direct project effects:

- a. All personnel associated with the project shall be instructed about the presence of manatees and manatee speed zones, and the need to avoid collisions with and injury to manatees. The permittee shall advise all construction personnel that there are civil and criminal penalties for harming, harassing, or killing manatees which are protected under the Marine Mammal Protection Act, the Endangered Species Act, and the Florida Manatee Sanctuary Act.
- b. All vessels associated with the construction project shall operate at "Idle Speed/No Wake" at all times while in the immediate area and while in water where the draft of the vessel provides less than a four-foot clearance from the bottom. All vessels will follow routes of deep water whenever possible.
- c. Siltation or turbidity barriers shall be made of material in which manatees cannot become entangled, shall be properly secured, and shall be regularly monitored to avoid manatee entanglement or entrapment. Barriers must not impede manatee movement.
- d. All on-site project personnel are responsible for observing water-related activities for the presence of manatee(s). All in-water operations, including vessels, must be shutdown if a manatee(s) comes within 50 feet of the operation. Activities will not resume until the manatee(s) has moved beyond the 50-foot radius of the project operation, or until 30 minutes elapses if the manatee(s) has not reappeared within 50 feet of the operation. Animals must not be herded away or harassed into leaving.
- e. Any collision with or injury to a manatee shall be reported immediately to the Florida Fish and Wildlife Conservation Commission (FWC) Hotline at 1-888-404-3922. Collision and/or injury should also be reported to the U.S. Fish and Wildlife Service in Jacksonville (1-904-731-3336) for north Florida or Vero Beach (1-772-562-3909) for south Florida, and to FWC at [ImperiledSpecies@myFWC.com](mailto:ImperiledSpecies@myFWC.com)
- f. Temporary signs concerning manatees shall be posted prior to and during all in-water project activities. All signs are to be removed by the permittee upon completion of the project. Temporary signs that have already been approved for this use by the FWC must be used. One sign which reads *Caution: Boaters* must be posted. A second sign measuring at least 8 ½" by 11" explaining the requirements for "Idle Speed/No Wake" and the shut down of in-water operations must be posted in a location prominently visible to all personnel engaged in water-related activities. These signs can be viewed at [MyFWC.com/manatee](http://MyFWC.com/manatee). Questions concerning these signs can be sent to the email address listed above.

# CAUTION: MANATEE HABITAT

All project vessels

**IDLE SPEED / NO WAKE**

When a manatee is within 50 feet of work  
all in-water activities must

**SHUT DOWN**

Report any collision with or injury to a manatee:

**Wildlife Alert:**

**1-888-404-FWCC(3922)**

cell \*FWC or #FWC

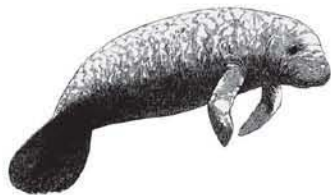

**AMENDMENT NO. 2  
TO AGREEMENT NO. 22FRP03  
BETWEEN  
FLORIDA DEPARTMENT OF ENVIRONMENTAL PROTECTION  
AND  
MANATEE COUNTY BOARD OF COUNTY COMMISSIONERS**

This Amendment to Agreement No. 22FRP03 (Agreement), as previously amended, is made by and between the Department of Environmental Protection (Department), an agency of the State of Florida, and Manatee County Board of County Commissioners (Grantee), on the date last signed below.

WHEREAS, the Department entered into the Agreement with the Grantee for Improving Resilience in Manatee County (Project), effective June 24, 2023; and,

WHEREAS, the Department has requested an update to the funding source from Line Item 152-D of the FY 21-22 General Appropriations Act to Line Item 1853 of the FY 24-25 General Appropriations Act; and,

WHEREAS, both parties have agreed to an extension of the Agreement Expiration Date for the Grantee to complete the required tasks in the Project and,

WHEREAS, the Department has requested an update to the Match Requirements in Attachment 2; and,

WHEREAS, the Department has requested an update to the Payment Request Schedule and Project Timeline in Attachment 3; and,

WHEREAS, the Department has requested an update to the funding source from Federal Resources to State Resources in Attachment 5; and,

WHEREAS, the Department has requested an update to Attachment 1, Attachment 2, Attachment 4, Attachment 6, and Attachment 8, following updates from the Office of the General Counsel.

WHEREAS, other changes to the Agreement are necessary.

NOW THEREFORE, the Department and Grantee hereby agree as follows:

1. Section 3. of the Standard Grant Agreement is hereby revised to change the Date of Expiration to June 30, 2027. The Department and the Grantee shall continue to perform their respective duties during this extension period pursuant to the same terms and conditions provided in the Agreement.
2. Section 5. of the Standard Grant Agreement is hereby revised to the following:

Total Amount of Funding:	Funding Source?	Award #s or Line Item Appropriations:	Amount per Source(s):
\$726,000.00	<input checked="" type="checkbox"/> State <input type="checkbox"/> Federal	FY 24-25 GAA Line Item #1853	\$726,000.00
	<input type="checkbox"/> State <input type="checkbox"/> Federal		
	<input type="checkbox"/> State <input type="checkbox"/> Federal		
	<input checked="" type="checkbox"/> Grantee Match		\$649,000.00
<b>Total Amount of Funding + Grantee Match, if any:</b>			<b>\$1,375,000.00</b>

3. Section 6. of the Standard Grant Agreement is hereby revised to the following:

<b>Department's Grant Manager</b>
Name: Katie Hoover
Address: 3900 Commonwealth Blvd, MS#230 Tallahassee, FL 32399
Phone: 850-245-7533
Email: Katharine.L.Hoover@FloridaDEP.gov

4. Attachment 1-A, Revised Standard Terms and Conditions, is hereby deleted in its entirety and replaced with Attachment 1-B, Second Revised Standard Terms and Conditions, as attached to this Amendment and hereby incorporated into the Agreement. All references in the Agreement to Attachment 1-A shall hereinafter refer to Attachment 1-B, Second Revised Standard Terms and Conditions.
5. Attachment 2-A, Revised Special Terms and Conditions, is hereby deleted in its entirety and replaced with Attachment 2-B, Second Revised Special Terms and Conditions, as attached to this Amendment and hereby incorporated into the Agreement. All references in the Agreement to Attachment 2-A shall hereinafter refer to Attachment 2-B, Second Revised Special Terms and Conditions.
6. Attachment 3-A, Revised Grant Work Plan, is hereby deleted in its entirety and replaced with Attachment 3-B, Second Revised Grant Work Plan, as attached to this Amendment and hereby incorporated into the Agreement. All references in the Agreement to Attachment 3-A shall hereinafter refer to Attachment 3-B, Second Revised Grant Work Plan.
7. Attachment 4, Public Records Requirements, is hereby deleted in its entirety and replaced with Attachment 4-A, Revised Public Records Requirements, as attached to this Amendment and hereby incorporated into the Agreement. All references in the Agreement to Attachment 4 shall hereinafter refer to Attachment 4-A, Revised Public Records Requirements.
8. Attachment 5-A, Revised Special Audit Requirements, is hereby deleted in its entirety and replaced with Attachment 5-B, Second Revised Special Audit Requirements, attached hereto and made a part of the Agreement. All references in the Agreement to Attachment 5-A, shall hereinafter refer to Attachment 5-B, Second Revised Special Audit Requirements.
9. Attachment 6, Program Specific Requirements, is hereby deleted in its entirety and replaced with Attachment 6-A, Revised Program Specific Requirements, attached hereto and made a part of the Agreement. All references in the Agreement to Attachment 6, shall hereinafter refer to Attachment 6-A, Revised Program Specific Requirements.
10. Attachment 8, Contract Provisions for Coronavirus State and Local Fiscal Recovery Funds (SLFRF) Agreements, is hereby deleted in its entirety and replaced with Attachment 8-A, Revised Contract Provisions for Coronavirus State and Local Fiscal Recovery Funds (SLFRF) Agreements, attached hereto and made a part of the Agreement. All references in the Agreement to Attachment 8, shall hereinafter refer to Attachment 8-A, Revised Contract Provisions for Coronavirus State and Local Fiscal Recovery Funds (SLFRF) Agreements.
11. All other terms and conditions of the Agreement remain in effect. If and to the extent that any inconsistency may appear between the Agreement and this Amendment, the provisions of this Amendment shall control.

The parties agree to the terms and conditions of this Amendment and have duly authorized their respective representatives to sign it on the dates indicated below.

MANATEE COUNTY BOARD OF COUNTY COMMISSIONERS

FLORIDA DEPARTMENT OF ENVIRONMENTAL PROTECTION

By:   
Authorized Representative or Designee

By:   
Secretary or Designee

Charlie Bishop, County Administrator  
Print Name and Title

Alex Reed, Director of the Office of Resilience and Coastal Protection  
Print Name and Title

Date: 9/9/24

Date: 09/16/2024

List of attachments/exhibits included as part of this Amendment:

Specify Type	Letter/ Number	Description
Attachment	1-B	Second Revised Standard Terms and Conditions (14 pages)
Attachment	2-B	Second Revised Special Terms and Conditions (3 pages)
Attachment	3-B	Second Revised Grant Work Plan (3 pages)
Attachment	4-A	Revised Public Records Requirements (1 page)
Attachment	5-B	Second Revised Special Audit Requirements (6 pages)
Attachment	6-A	Revised Program Specific Requirements (2 pages)
Attachment	8-A	Revised Contract Provisions for Coronavirus State and Local Fiscal Recovery Funds (SLFRF) Agreements (6 pages)

**STATE OF FLORIDA  
DEPARTMENT OF ENVIRONMENTAL PROTECTION  
SECOND REVISED STANDARD TERMS AND  
CONDITIONS APPLICABLE TO GRANT  
AGREEMENTS**

**ATTACHMENT 1-B**

**1. Entire Agreement.**

This Grant Agreement, including any Attachments and Exhibits referred to herein and/or attached hereto (Agreement), constitutes the entire agreement between the parties with respect to the subject matter hereof and supersedes all prior agreements, whether written or oral, with respect to such subject matter. Any terms and conditions included on Grantee's forms or invoices shall be null and void.

**2. Grant Administration.**

- a. Order of Precedence. If there are conflicting provisions among the documents that make up the Agreement, the order of precedence for interpretation of the Agreement is as follows:
- i. Standard Grant Agreement
  - ii. Attachments other than Attachment 1, in numerical order as designated in the Standard Grant Agreement
  - iii. Attachment 1, Standard Terms and Conditions
  - iv. The Exhibits in the order designated in the Standard Grant Agreement
- b. All approvals, written or verbal, and other written communication among the parties, including all notices, shall be obtained by or sent to the parties' Grant Managers. All written communication shall be by electronic mail, U.S. Mail, a courier delivery service, or delivered in person. Notices shall be considered delivered when reflected by an electronic mail read receipt, a courier service delivery receipt, other mail service delivery receipt, or when receipt is acknowledged by recipient. If the notice is delivered in multiple ways, the notice will be considered delivered at the earliest delivery time.
- c. If a different Grant Manager is designated by either party after execution of this Agreement, notice of the name and contact information of the new Grant Manager will be submitted in writing to the other party and maintained in the respective parties' records. A change of Grant Manager does not require a formal amendment or change order to the Agreement.
- d. This Agreement may be amended, through a formal amendment or a change order, only by a written agreement between both parties. A formal amendment to this Agreement is required for changes which cause any of the following:
- (1) an increase or decrease in the Agreement funding amount;
  - (2) a change in Grantee's match requirements;
  - (3) a change in the expiration date of the Agreement; and/or
  - (4) changes to the cumulative amount of funding transfers between approved budget categories, as defined in Attachment 3, Grant Work Plan, that exceeds or is expected to exceed twenty percent (20%) of the total budget as last approved by Department.
- A change order to this Agreement may be used when:
- (1) task timelines within the current authorized Agreement period change;
  - (2) the cumulative transfer of funds between approved budget categories, as defined in Attachment 3, Grant Work Plan, are less than twenty percent (20%) of the total budget as last approved by Department;
  - (3) changing the current funding source as stated in the Standard Grant Agreement; and/or
  - (4) fund transfers between budget categories for the purposes of meeting match requirements.
- This Agreement may be amended to provide for additional services if additional funding is made available by the Legislature.
- e. All days in this Agreement are calendar days unless otherwise specified.

**3. Agreement Duration.**

The term of the Agreement shall begin and end on the dates indicated in the Standard Grant Agreement, unless extended or terminated earlier in accordance with the applicable terms and conditions. The Grantee shall be eligible for reimbursement for work performed on or after the date of execution through the expiration date of this Agreement, unless otherwise specified in Attachment 2, Special Terms and Conditions. However, work performed prior to the execution of this Agreement may be reimbursable or used for match purposes if permitted by the Special Terms and Conditions.

**Attachment 1- B**

1 of 14



#### **4. Deliverables.**

The Grantee agrees to render the services or other units of deliverables as set forth in Attachment 3, Grant Work Plan. The services or other units of deliverables shall be delivered in accordance with the schedule and at the pricing outlined in the Grant Work Plan. Deliverables may be comprised of activities that must be completed prior to Department making payment on that deliverable. The Grantee agrees to perform in accordance with the terms and conditions set forth in this Agreement and all attachments and exhibits incorporated by the Standard Grant Agreement.

#### **5. Performance Measures.**

The Grantee warrants that: (1) the services will be performed by qualified personnel; (2) the services will be of the kind and quality described in the Grant Work Plan; (3) the services will be performed in a professional and workmanlike manner in accordance with industry standards and practices; (4) the services shall not and do not knowingly infringe upon the intellectual property rights, or any other proprietary rights, of any third party; and (5) its employees, subcontractors, and/or subgrantees shall comply with any security and safety requirements and processes, if provided by Department, for work done at the Project Location(s). The Department reserves the right to investigate or inspect at any time to determine whether the services or qualifications offered by Grantee meet the Agreement requirements. Notwithstanding any provisions herein to the contrary, written acceptance of a particular deliverable does not foreclose Department's remedies in the event deficiencies in the deliverable cannot be readily measured at the time of delivery.

#### **6. Acceptance of Deliverables.**

- a. Acceptance Process. All deliverables must be received and accepted in writing by Department's Grant Manager before payment. The Grantee shall work diligently to correct all deficiencies in the deliverable that remain outstanding, within a reasonable time at Grantee's expense. If Department's Grant Manager does not accept the deliverables within 30 days of receipt, they will be deemed rejected.
- b. Rejection of Deliverables. The Department reserves the right to reject deliverables, as outlined in the Grant Work Plan, as incomplete, inadequate, or unacceptable due, in whole or in part, to Grantee's lack of satisfactory performance under the terms of this Agreement. The Grantee's efforts to correct the rejected deliverables will be at Grantee's sole expense. Failure to fulfill the applicable technical requirements or complete all tasks or activities in accordance with the Grant Work Plan will result in rejection of the deliverable and the associated invoice. Payment for the rejected deliverable will not be issued unless the rejected deliverable is made acceptable to Department in accordance with the Agreement requirements. The Department, at its option, may allow additional time within which Grantee may remedy the objections noted by Department. The Grantee's failure to make adequate or acceptable deliverables after a reasonable opportunity to do so shall constitute an event of default.

#### **7. Financial Consequences for Nonperformance.**

- a. Withholding Payment. In addition to the specific consequences explained in the Grant Work Plan and/or Special Terms and Conditions, the State of Florida (State) reserves the right to withhold payment when the Grantee has failed to perform/comply with provisions of this Agreement. None of the financial consequences for nonperformance in this Agreement as more fully described in the Grant Work Plan shall be considered penalties.
- b. Invoice reduction  
If Grantee does not meet a deadline for any deliverable, the Department will reduce the invoice by 1% for each day the deadline is missed, unless an extension is approved in writing by the Department.
- c. Corrective Action Plan. If Grantee fails to correct all the deficiencies in a rejected deliverable within the specified timeframe, Department may, in its sole discretion, request that a proposed Corrective Action Plan (CAP) be submitted by Grantee to Department. The Department requests that Grantee specify the outstanding deficiencies in the CAP. All CAPs must be able to be implemented and performed in no more than sixty (60) calendar days.
  - i. The Grantee shall submit a CAP within ten (10) days of the date of the written request from Department. The CAP shall be sent to the Department's Grant Manager for review and approval. Within ten (10) days of receipt of a CAP, Department shall notify Grantee in writing whether the CAP proposed has been accepted. If the CAP is not accepted, Grantee shall have ten (10) days from receipt of Department letter rejecting the proposal to submit a revised proposed CAP. Failure to obtain Department approval of a CAP as specified above may result in Department's termination of this Agreement for cause as authorized in this Agreement.
  - ii. Upon Department's notice of acceptance of a proposed CAP, Grantee shall have ten (10) days to commence implementation of the accepted plan. Acceptance of the proposed CAP by Department

#### **Attachment 1-B**

2 of 14

does not relieve Grantee of any of its obligations under the Agreement. In the event the CAP fails to correct or eliminate performance deficiencies by Grantee, Department shall retain the right to require additional or further remedial steps, or to terminate this Agreement for failure to perform. No actions approved by Department or steps taken by Grantee shall preclude Department from subsequently asserting any deficiencies in performance. The Grantee shall continue to implement the CAP until all deficiencies are corrected. Reports on the progress of the CAP will be made to Department as requested by Department's Grant Manager.

- iii. Failure to respond to a Department request for a CAP or failure to correct a deficiency in the performance of the Agreement as specified by Department may result in termination of the Agreement.

**8. Payment.**

- a. Payment Process. Subject to the terms and conditions established by the Agreement, the pricing per deliverable established by the Grant Work Plan, and the billing procedures established by Department, Department agrees to pay Grantee for services rendered in accordance with section 215.422, Florida Statutes (F.S.).
- b. Taxes. The Department is exempted from payment of State sales, use taxes and Federal excise taxes. The Grantee, however, shall not be exempted from paying any taxes that it is subject to, including State sales and use taxes, or for payment by Grantee to suppliers for taxes on materials used to fulfill its contractual obligations with Department. The Grantee shall not use Department's exemption number in securing such materials. The Grantee shall be responsible and liable for the payment of all its FICA/Social Security and other taxes resulting from this Agreement.
- c. Maximum Amount of Agreement. The maximum amount of compensation under this Agreement, without an amendment, is described in the Standard Grant Agreement. Any additional funds necessary for the completion of this Project are the responsibility of Grantee.
- d. Reimbursement for Costs. The Grantee shall be paid on a cost reimbursement basis for all eligible Project costs upon the completion, submittal, and approval of each deliverable identified in the Grant Work Plan. Reimbursement shall be requested on Exhibit C, Payment Request Summary Form. To be eligible for reimbursement, costs must be in compliance with laws, rules, and regulations applicable to expenditures of State funds, including, but not limited to, the Reference Guide for State Expenditures, which can be accessed at the following web address: <https://www.myfloridacfo.com/docs-sf/accounting-and-auditing-libraries/state-agencies/reference-guide-for-state-expenditures.pdf>.
- e. Rural Communities and Rural Areas of Opportunity. If Grantee is a county or municipality that qualifies as a "rural community" or "rural area of opportunity" (RAO) as defined in subsection 288.0656(2), F.S., such Grantee may request from the Department that all invoice payments under this Agreement be directed to the relevant county or municipality or to the RAO itself. The Department will agree to Grantee's request if:
  - i. Grantee demonstrates that it is a county or municipality that qualifies as a "rural community" or "rural area of opportunity" under subsection 288.0656(2), F.S.;
  - ii. Grantee demonstrates current financial hardship using one (1) or more of the "economic distress" factors defined in subsection 288.0656(2)(c), F.S.;
  - iii. Grantee's performance has been verified by the Department, which has determined that Grantee is eligible for invoice payments and that Grantee's performance has been completed in accordance with this Agreement's terms and conditions; and
  - iv. Applicable federal and state law(s), rule(s) and regulation(s) allow for such payments.This subsection may not be construed to alter or limit any other applicable provisions of federal or state law, rule, or regulation. A current list of Florida's designated RAOs can be accessed at the following web address: <https://floridajobs.org/community-planning-and-development/rural-community-programs/rural-areas-of-opportunity>.
- f. Invoice Detail. All charges for services rendered or for reimbursement of expenses authorized by Department pursuant to the Grant Work Plan shall be submitted to Department in sufficient detail for a proper pre-audit and post-audit to be performed. The Grantee shall only invoice Department for deliverables that are completed in accordance with the Grant Work Plan.
- g. State Funds Documentation. Pursuant to section 216.1366, F.S., if Contractor meets the definition of a non-profit organization under section 215.97(2)(m), F.S., Contractor must provide the Department with documentation that indicates the amount of state funds:
  - i. Allocated to be used during the full term of the contract or agreement for remuneration to any member of the board of directors or an officer of Contractor.

**Attachment 1-B**

3 of 14

- ii. Allocated under each payment by the public agency to be used for remuneration of any member of the board of directors or an officer of the Contractor.

The documentation must indicate the amounts and recipients of the remuneration. Such information must be posted on the State's the contract tracking system and maintained pursuant to section 215.985, F.S., and must be posted on the Contractor's website, if Contractor maintains a website.

- h. Interim Payments. Interim payments may be made by Department, at its discretion, if the completion of deliverables to date have first been accepted in writing by Department's Grant Manager.
- i. Final Payment Request. A final payment request should be submitted to Department no later than sixty (60) days following the expiration date of the Agreement to ensure the availability of funds for payment. However, all work performed pursuant to the Grant Work Plan must be performed on or before the expiration date of the Agreement.
- j. Annual Appropriation Contingency. The State's performance and obligation to pay under this Agreement is contingent upon an annual appropriation by the Legislature. This Agreement is not a commitment of future appropriations. Authorization for continuation and completion of work and any associated payments may be rescinded, with proper notice, at the discretion of Department if the Legislature reduces or eliminates appropriations.
- k. Interest Rates. All interest rates charged under the Agreement shall be calculated on the prevailing rate used by the State Board of Administration. To obtain the applicable interest rate, please refer to: <https://www.myfloridacfo.com/division/aa/local-governments/judgement-interest-rates>.
- l. Refund of Payments to the Department. Any balance of unobligated funds that have been advanced or paid must be refunded to Department. Any funds paid in excess of the amount to which Grantee or subgrantee is entitled under the terms of the Agreement must be refunded to Department. If this Agreement is funded with federal funds and the Department is required to refund the federal government, the Grantee shall refund the Department its share of those funds.

#### **9. Documentation Required for Cost Reimbursement Grant Agreements and Match.**

If Cost Reimbursement or Match is authorized in Attachment 2, Special Terms and Conditions, the following conditions apply. Supporting documentation must be provided to substantiate cost reimbursement or match requirements for the following budget categories:

- a. Salary/Wages. Grantee shall list personnel involved, position classification, direct salary rates, and hours spent on the Project in accordance with Attachment 3, Grant Work Plan in their documentation for reimbursement or match requirements.
- b. Overhead/Indirect/General and Administrative Costs. If Grantee is being reimbursed for or claiming match for multipliers, all multipliers used (i.e., fringe benefits, overhead, indirect, and/or general and administrative rates) shall be supported by audit. If Department determines that multipliers charged by Grantee exceeded the rates supported by audit, Grantee shall be required to reimburse such funds to Department within thirty (30) days of written notification. Interest shall be charged on the excessive rate.
- c. Contractual Costs (Subcontractors). Match or reimbursement requests for payments to subcontractors must be substantiated by copies of invoices with backup documentation identical to that required from Grantee. Subcontracts which involve payments for direct salaries shall clearly identify the personnel involved, salary rate per hour, and hours spent on the Project. All eligible multipliers used (i.e., fringe benefits, overhead, indirect, and/or general and administrative rates) shall be supported by audit. If Department determines that multipliers charged by any subcontractor exceeded the rates supported by audit, Grantee shall be required to reimburse such funds to Department within thirty (30) days of written notification. Interest shall be charged on the excessive rate. Nonconsumable and/or nonexpendable personal property or equipment costing \$5,000 or more purchased for the Project under a subcontract is subject to the requirements set forth in chapters 273 and/or 274, F.S., and Chapter 69I-72, Florida Administrative Code (F.A.C.) and/or Chapter 69I-73, F.A.C., as applicable. The Grantee shall be responsible for maintaining appropriate property records for any subcontracts that include the purchase of equipment as part of the delivery of services. The Grantee shall comply with this requirement and ensure its subcontracts issued under this Agreement, if any, impose this requirement, in writing, on its subcontractors.
  - i. For fixed-price (vendor) subcontracts, the following provisions shall apply: The Grantee may award, on a competitive basis, fixed-price subcontracts to consultants/contractors in performing the work described in Attachment 3, Grant Work Plan. Invoices submitted to Department for fixed-price subcontracted activities shall be supported with a copy of the subcontractor's invoice and a copy of the tabulation form for the competitive procurement process (e.g., Invitation to Bid, Request for Proposals, or other similar competitive procurement document) resulting in the fixed-price

#### **Attachment 1-B**

4 of 14

subcontract. The Grantee may request approval from Department to award a fixed-price subcontract resulting from procurement methods other than those identified above. In this instance, Grantee shall request the advance written approval from Department's Grant Manager of the fixed price negotiated by Grantee. The letter of request shall be supported by a detailed budget and Scope of Services to be performed by the subcontractor. Upon receipt of Department Grant Manager's approval of the fixed-price amount, Grantee may proceed in finalizing the fixed-price subcontract.

- ii. If the procurement is subject to the Consultant's Competitive Negotiation Act under section 287.055, F.S. or the Brooks Act, Grantee must provide documentation clearly evidencing it has complied with the statutory or federal requirements.
- d. Travel. All requests for match or reimbursement of travel expenses shall be in accordance with section 112.061, F.S.
- e. Direct Purchase Equipment. For the purposes of this Agreement, Equipment is defined as capital outlay costing \$5,000 or more. Match or reimbursement for Grantee's direct purchase of equipment is subject to specific approval of Department, and does not include any equipment purchased under the delivery of services to be completed by a subcontractor. Include copies of invoices or receipts to document purchases, and a properly completed Exhibit B, Property Reporting Form.
- f. Rental/Lease of Equipment. Match or reimbursement requests for rental/lease of equipment must include copies of invoices or receipts to document charges.
- g. Miscellaneous/Other Expenses. If miscellaneous or other expenses, such as materials, supplies, non-excluded phone expenses, reproduction, or mailing, are reimbursable or available for match or reimbursement under the terms of this Agreement, the documentation supporting these expenses must be itemized and include copies of receipts or invoices. Additionally, independent of Grantee's contract obligations to its subcontractor, Department shall not reimburse any of the following types of charges: cell phone usage; attorney's fees or court costs; civil or administrative penalties; or handling fees, such as set percent overages associated with purchasing supplies or equipment.
- h. Land Acquisition. Reimbursement for the costs associated with acquiring interest and/or rights to real property (including access rights through ingress/egress easements, leases, license agreements, or other site access agreements; and/or obtaining record title ownership of real property through purchase) must be supported by the following, as applicable: Copies of Property Appraisals, Environmental Site Assessments, Surveys and Legal Descriptions, Boundary Maps, Acreage Certification, Title Search Reports, Title Insurance, Closing Statements/Documents, Deeds, Leases, Easements, License Agreements, or other legal instrument documenting acquired property interest and/or rights. If land acquisition costs are used to meet match requirements, Grantee agrees that those funds shall not be used as match for any other Agreement supported by State or Federal funds.

#### **10. Status Reports.**

The Grantee shall submit status reports quarterly, unless otherwise specified in the Attachments, on Exhibit A, Progress Report Form, to Department's Grant Manager describing the work performed during the reporting period, problems encountered, problem resolutions, scheduled updates, and proposed work for the next reporting period. Quarterly status reports are due no later than twenty (20) days following the completion of the quarterly reporting period. For the purposes of this reporting requirement, the quarterly reporting periods end on March 31, June 30, September 30 and December 31. The Department will review the required reports submitted by Grantee within thirty (30) days.

#### **11. Retainage.**

The following provisions apply if Department withholds retainage under this Agreement:

- a. The Department reserves the right to establish the amount and application of retainage on the work performed under this Agreement up to the maximum percentage described in Attachment 2, Special Terms and Conditions. Retainage may be withheld from each payment to Grantee pending satisfactory completion of work and approval of all deliverables.
- b. If Grantee fails to perform the requested work or fails to perform the work in a satisfactory manner, Grantee shall forfeit its right to payment of the retainage associated with the work. Failure to perform includes, but is not limited to, failure to submit the required deliverables or failure to provide adequate documentation that the work was actually performed. The Department shall provide written notification to Grantee of the failure to perform that shall result in retainage forfeiture. If the Grantee does not correct the failure to perform within the timeframe stated in Department's notice, the retainage will be forfeited to Department.
- c. No retainage shall be released or paid for incomplete work while this Agreement is suspended.

#### **Attachment 1-B**

5 of 14

- d. Except as otherwise provided above, Grantee shall be paid the retainage associated with the work, provided Grantee has completed the work and submits an invoice for retainage held in accordance with the invoicing procedures under this Agreement.

**12. Insurance.**

- a. Insurance Requirements for Sub-Grantees and/or Subcontractors. The Grantee shall require its sub-grantees and/or subcontractors, if any, to maintain insurance coverage of such types and with such terms and limits as described in this Agreement. The Grantee shall require all its sub-grantees and/or subcontractors, if any, to make compliance with the insurance requirements of this Agreement a condition of all contracts that are related to this Agreement. Sub-grantees and/or subcontractors must provide proof of insurance upon request.
- b. Deductibles. The Department shall be exempt from, and in no way liable for, any sums of money representing a deductible in any insurance policy. The payment of such deductible shall be the sole responsibility of the Grantee providing such insurance.
- c. Proof of Insurance. Upon execution of this Agreement, Grantee shall provide Department documentation demonstrating the existence and amount for each type of applicable insurance coverage *prior to* performance of any work under this Agreement. Upon receipt of written request from Department, Grantee shall furnish Department with proof of applicable insurance coverage by standard form certificates of insurance, a self-insured authorization, or other certification of self-insurance.
- d. Duty to Maintain Coverage. In the event that any applicable coverage is cancelled by the insurer for any reason, or if Grantee cannot get adequate coverage, Grantee shall immediately notify Department of such cancellation and shall obtain adequate replacement coverage conforming to the requirements herein and provide proof of such replacement coverage within ten (10) days after the cancellation of coverage.
- e. Insurance Trust. If the Grantee's insurance is provided through an insurance trust, the Grantee shall instead add the Department of Environmental Protection, its employees, and officers as an additional covered party everywhere the Agreement requires them to be added as an additional insured.

**13. Termination.**

- a. Termination for Convenience. When it is in the State's best interest, Department may, at its sole discretion, terminate the Agreement in whole or in part by giving 30 days' written notice to Grantee. The Department shall notify Grantee of the termination for convenience with instructions as to the effective date of termination or the specific stage of work at which the Agreement is to be terminated. The Grantee must submit all invoices for work to be paid under this Agreement within thirty (30) days of the effective date of termination. The Department shall not pay any invoices received after thirty (30) days of the effective date of termination.
- b. Termination for Cause. The Department may terminate this Agreement if any of the events of default described in the Events of Default provisions below occur or in the event that Grantee fails to fulfill any of its other obligations under this Agreement. If, after termination, it is determined that Grantee was not in default, or that the default was excusable, the rights and obligations of the parties shall be the same as if the termination had been issued for the convenience of Department. The rights and remedies of Department in this clause are in addition to any other rights and remedies provided by law or under this Agreement.
- c. Grantee Obligations upon Notice of Termination. After receipt of a notice of termination or partial termination unless as otherwise directed by Department, Grantee shall not furnish any service or deliverable on the date, and to the extent specified, in the notice. However, Grantee shall continue work on any portion of the Agreement not terminated. If the Agreement is terminated before performance is completed, Grantee shall be paid only for that work satisfactorily performed for which costs can be substantiated. The Grantee shall not be entitled to recover any cancellation charges or lost profits.
- d. Continuation of Prepaid Services. If Department has paid for any services prior to the expiration, cancellation, or termination of the Agreement, Grantee shall continue to provide Department with those services for which it has already been paid or, at Department's discretion, Grantee shall provide a refund for services that have been paid for but not rendered.
- e. Transition of Services Upon Termination, Expiration, or Cancellation of the Agreement. If services provided under the Agreement are being transitioned to another provider(s), Grantee shall assist in the smooth transition of Agreement services to the subsequent provider(s). This requirement is at a minimum an affirmative obligation to cooperate with the new provider(s), however additional requirements may be outlined in the Grant Work Plan. The Grantee shall not perform any services after Agreement expiration or termination, except as necessary to complete the transition or continued portion of the Agreement, if any.

**14. Notice of Default.**

**Attachment 1-B**

6 of 14

If Grantee defaults in the performance of any covenant or obligation contained in the Agreement, including, any of the events of default, Department shall provide notice to Grantee and an opportunity to cure that is reasonable under the circumstances. This notice shall state the nature of the failure to perform and provide a time certain for correcting the failure. The notice will also provide that, should the Grantee fail to perform within the time provided, Grantee will be found in default, and Department may terminate the Agreement effective as of the date of receipt of the default notice.

#### **15. Events of Default.**

Provided such failure is not the fault of Department or outside the reasonable control of Grantee, the following non-exclusive list of events, acts, or omissions, shall constitute events of default:

- a. The commitment of any material breach of this Agreement by Grantee, including failure to timely deliver a material deliverable, failure to perform the minimal level of services required for a deliverable, discontinuance of the performance of the work, failure to resume work that has been discontinued within a reasonable time after notice to do so, or abandonment of the Agreement;
- b. The commitment of any material misrepresentation or omission in any materials, or discovery by the Department of such, made by the Grantee in this Agreement or in its application for funding;
- c. Failure to submit any of the reports required by this Agreement or having submitted any report with incorrect, incomplete, or insufficient information;
- d. Failure to honor any term of the Agreement;
- e. Failure to abide by any statutory, regulatory, or licensing requirement, including an entry of an order revoking the certificate of authority granted to the Grantee by a state or other licensing authority;
- f. Failure to pay any and all entities, individuals, and furnishing labor or materials, or failure to make payment to any other entities as required by this Agreement;
- g. Employment of an unauthorized alien in the performance of the work, in violation of Section 274 (A) of the Immigration and Nationality Act;
- h. Failure to maintain the insurance required by this Agreement;
- i. One or more of the following circumstances, uncorrected for more than thirty (30) days unless, within the specified 30-day period, Grantee (including its receiver or trustee in bankruptcy) provides to Department adequate assurances, reasonably acceptable to Department, of its continuing ability and willingness to fulfill its obligations under the Agreement:
  - i. Entry of an order for relief under Title 11 of the United States Code;
  - ii. The making by Grantee of a general assignment for the benefit of creditors;
  - iii. The appointment of a general receiver or trustee in bankruptcy of Grantee's business or property; and/or
  - iv. An action by Grantee under any state insolvency or similar law for the purpose of its bankruptcy, reorganization, or liquidation.

#### **16. Suspension of Work.**

The Department may, in its sole discretion, suspend any or all activities under the Agreement, at any time, when it is in the best interest of the State to do so. The Department shall provide Grantee written notice outlining the particulars of suspension. Examples of reasons for suspension include, but are not limited to, budgetary constraints, declaration of emergency, or other such circumstances. After receiving a suspension notice, Grantee shall comply with the notice. Within 90 days, or any longer period agreed to by the parties, Department shall either: (1) issue a notice authorizing resumption of work, at which time activity shall resume; or (2) terminate the Agreement. If the Agreement is terminated after 30 days of suspension, the notice of suspension shall be deemed to satisfy the thirty (30) days' notice required for a notice of termination for convenience. Suspension of work shall not entitle Grantee to any additional compensation.

#### **17. Force Majeure.**

The Grantee shall not be responsible for delay resulting from its failure to perform if neither the fault nor the negligence of Grantee or its employees or agents contributed to the delay and the delay is due directly to acts of God, wars, acts of public enemies, strikes, fires, floods, or other similar cause wholly beyond Grantee's control, or for any of the foregoing that affect subcontractors or suppliers if no alternate source of supply is available to Grantee. In case of any delay Grantee believes is excusable, Grantee shall notify Department in writing of the delay or potential delay and describe the cause of the delay either (1) within ten days after the cause that creates or will create the delay first arose, if Grantee could reasonably foresee that a delay could occur as a result; or (2) if delay is not reasonably foreseeable, within five days after the date Grantee first had reason to believe that a delay could result. **THE FOREGOING SHALL CONSTITUTE THE GRANTEE'S SOLE REMEDY OR EXCUSE WITH RESPECT**

#### **Attachment 1-B**

7 of 14

**TO DELAY.** Providing notice in strict accordance with this paragraph is a condition precedent to such remedy. No claim for damages, other than for an extension of time, shall be asserted against Department. The Grantee shall not be entitled to an increase in the Agreement price or payment of any kind from Department for direct, indirect, consequential, impact or other costs, expenses or damages, including but not limited to costs of acceleration or inefficiency, arising because of delay, disruption, interference, or hindrance from any cause whatsoever. If performance is suspended or delayed, in whole or in part, due to any of the causes described in this paragraph, after the causes have ceased to exist Grantee shall perform at no increased cost, unless Department determines, in its sole discretion, that the delay will significantly impair the value of the Agreement to Department, in which case Department may: (1) accept allocated performance or deliveries from Grantee, provided that Grantee grants preferential treatment to Department with respect to products subjected to allocation; (2) contract with other sources (without recourse to and by Grantee for the related costs and expenses) to replace all or part of the products or services that are the subject of the delay, which purchases may be deducted from the Agreement quantity; or (3) terminate Agreement in whole or in part.

**18. Indemnification.**

- a. The Grantee shall be fully liable for the actions of its agents, employees, partners, or subcontractors and shall fully indemnify, defend, and hold harmless Department and its officers, agents, and employees, from suits, actions, damages, and costs of every name and description arising from or relating to:
  - i. personal injury and damage to real or personal tangible property alleged to be caused in whole or in part by Grantee, its agents, employees, partners, or subcontractors; provided, however, that Grantee shall not indemnify for that portion of any loss or damages proximately caused by the negligent act or omission of Department;
  - ii. the Grantee's breach of this Agreement or the negligent acts or omissions of Grantee.
- b. The Grantee's obligations under the preceding paragraph with respect to any legal action are contingent upon Department giving Grantee: (1) written notice of any action or threatened action; (2) the opportunity to take over and settle or defend any such action at Grantee's sole expense; and (3) assistance in defending the action at Grantee's sole expense. The Grantee shall not be liable for any cost, expense, or compromise incurred or made by Department in any legal action without Grantee's prior written consent, which shall not be unreasonably withheld.
- c. Notwithstanding sections a. and b. above, the following is the sole indemnification provision that applies to Grantees that are governmental entities: Each party hereto agrees that it shall be solely responsible for the negligent or wrongful acts of its employees and agents. However, nothing contained herein shall constitute a waiver by either party of its sovereign immunity or the provisions of section 768.28, F.S. Further, nothing herein shall be construed as consent by a state agency or subdivision of the State to be sued by third parties in any matter arising out of any contract or this Agreement.
- d. No provision in this Agreement shall require Department to hold harmless or indemnify Grantee, insure or assume liability for Grantee's negligence, waive Department's sovereign immunity under the laws of Florida, or otherwise impose liability on Department for which it would not otherwise be responsible. Any provision, implication or suggestion to the contrary is null and void.

**19. Limitation of Liability.**

The Department's liability for any claim arising from this Agreement is limited to compensatory damages in an amount no greater than the sum of the unpaid balance of compensation due for goods or services rendered pursuant to and in compliance with the terms of the Agreement. Such liability is further limited to a cap of \$100,000.

**20. Remedies.**

Nothing in this Agreement shall be construed to make Grantee liable for force majeure events. Nothing in this Agreement, including financial consequences for nonperformance, shall limit Department's right to pursue its remedies for other types of damages under the Agreement, at law or in equity. The Department may, in addition to other remedies available to it, at law or in equity and upon notice to Grantee, retain such monies from amounts due Grantee as may be necessary to satisfy any claim for damages, penalties, costs and the like asserted by or against it.

**21. Waiver.**

The delay or failure by Department to exercise or enforce any of its rights under this Agreement shall not constitute or be deemed a waiver of Department's right thereafter to enforce those rights, nor shall any single or partial exercise of any such right preclude any other or further exercise thereof or the exercise of any other right.

**22. Statutory Notices Relating to Unauthorized Employment and Subcontracts.**

- a. The Department shall consider the employment by any Grantee of unauthorized aliens a violation of Section 274A(e) of the Immigration and Nationality Act. If Grantee/subcontractor knowingly employs unauthorized

aliens, such violation shall be cause for unilateral cancellation of this Agreement. The Grantee shall be responsible for including this provision in all subcontracts with private organizations issued as a result of this Agreement.

- b. Pursuant to sections 287.133, 287.134, and 287.137 F.S., the following restrictions apply to persons placed on the convicted vendor list, discriminatory vendor list, or the antitrust violator vendor list:
  - i. Public Entity Crime. A person or affiliate who has been placed on the convicted vendor list following a conviction for a public entity crime may not submit a bid, proposal, or reply on a contract to provide any goods or services to a public entity; may not submit a bid, proposal, or reply on a contract with a public entity for the construction or repair of a public building or public work; may not submit bids, proposals, or replies on leases of real property to a public entity; may not be awarded or perform work as a Grantee, supplier, subcontractor, or consultant under a contract with any public entity; and may not transact business with any public entity in excess of the threshold amount provided in section 287.017, F.S., for CATEGORY TWO for a period of 36 months following the date of being placed on the convicted vendor list.
  - ii. Discriminatory Vendors. An entity or affiliate who has been placed on the discriminatory vendor list may not submit a bid, proposal, or reply on a contract to provide any goods or services to a public entity; may not submit a bid, proposal, or reply on a contract with a public entity for the construction or repair of a public building or public work; may not submit bids, proposals, or replies on leases of real property to a public entity; may not be awarded or perform work as a contractor, supplier, subcontractor, or consultant under a contract with any public entity; and may not transact business with any public entity.
  - iii. Antitrust Violator Vendors. A person or an affiliate who has been placed on the antitrust violator vendor list following a conviction or being held civilly liable for an antitrust violation may not submit a bid, proposal, or reply on any contract to provide any good or services to a public entity; may not submit a bid, proposal, or reply on any contract with a public entity for the construction or repair of a public building or public work; may not submit a bid, proposal, or reply on leases of real property to a public entity; may not be awarded or perform work as a Grantee, supplier, subcontractor, or consultant under a contract with a public entity; and may not transact new business with a public entity.
  - iv. Notification. The Grantee shall notify Department if it or any of its suppliers, subcontractors, or consultants have been placed on the convicted vendor list, the discriminatory vendor list, or antitrust violator vendor list during the life of the Agreement. The Florida Department of Management Services is responsible for maintaining the discriminatory vendor list and the antitrust violator vendor list and posts the list on its website. Questions regarding the discriminatory vendor list or antitrust violator vendor list may be directed to the Florida Department of Management Services, Office of Supplier Diversity, at (850) 487-0915.

**23. Compliance with Federal, State and Local Laws.**

- a. The Grantee and all its agents shall comply with all federal, state and local regulations, including, but not limited to, nondiscrimination, wages, social security, workers' compensation, licenses, and registration requirements. The Grantee shall include this provision in all subcontracts issued as a result of this Agreement.
- b. No person, on the grounds of race, creed, color, religion, national origin, age, gender, or disability, shall be excluded from participation in; be denied the proceeds or benefits of; or be otherwise subjected to discrimination in performance of this Agreement.
- c. This Agreement shall be governed by and construed in accordance with the laws of the State of Florida.
- d. Any dispute concerning performance of the Agreement shall be processed as described herein. Jurisdiction for any damages arising under the terms of the Agreement will be in the courts of the State, and venue will be in the Second Judicial Circuit, in and for Leon County. Except as otherwise provided by law, the parties agree to be responsible for their own attorney fees incurred in connection with disputes arising under the terms of this Agreement.

**24. Build America, Buy America Act (BABA) - Infrastructure Projects with Federal Funding.**

**This provision does not apply to Agreements that are wholly funded by Coronavirus State and Local Fiscal Recovery Funds under the American Rescue Plan Act. Also, this provision does not apply where there is a valid waiver in place. However, the provision may apply to funds expended before the waiver or after expiration of the waiver.**



If applicable, Recipients or Subrecipients of an award of Federal financial assistance from a program for infrastructure are required to comply with the Build America, Buy America Act (BABA), including the following provisions:

- a. All iron and steel used in the project are produced in the United States--this means all manufacturing processes, from the initial melting stage through the application of coatings, occurred in the United States;
- b. All manufactured products used in the project are produced in the United States--this means the manufactured product was manufactured in the United States; and the cost of the components of the manufactured product that are mined, produced, or manufactured in the United States is greater than 55 percent of the total cost of all components of the manufactured product, unless another standard for determining the minimum amount of domestic content of the manufactured product has been established under applicable law or regulation; and
- c. All construction materials are manufactured in the United States--this means that all manufacturing processes for the construction material occurred in the United States.

The Buy America preference only applies to articles, materials, and supplies that are consumed in, incorporated into, or affixed to an infrastructure project. As such, it does not apply to tools, equipment, and supplies, such as temporary scaffolding, brought to the construction site and removed at or before the completion of the infrastructure project. Nor does a Buy America preference apply to equipment and furnishings, such as movable chairs, desks, and portable computer equipment, that are used at or within the finished infrastructure project but are not an integral part of the structure or permanently affixed to the infrastructure project.

## **25. Investing in America**

Grantees of an award for construction projects in whole or in part by the Bipartisan Infrastructure Law or the Inflation Reduction Act, including the following provision:

- a. Signage Requirements
  - a. Investing in America Emblem: The recipient will ensure that a sign is placed at construction sites supported in whole or in part by this award displaying the official Investing in America emblem and must identify the project as a “project funded by President Biden’s Bipartisan Infrastructure Law” or “project funded by President Biden’s Inflation Reduction Act” as applicable. The sign must be placed at construction sites in an easily visible location that can be directly linked to the work taking place and must be maintained in good condition throughout the construction period.  
The recipient will ensure compliance with the guidelines and design specifications provided by EPA for using the official Investing in America emblem available at: <https://www.epa.gov/invest/investing-america-signage>.
  - b. Procuring Signs: Consistent with section 6002 of RCRA, 42 U.S.C. 6962, and 2 CFR 200.323, recipients are encouraged to use recycled or recovered materials when procuring signs. Signage costs are considered an allowable cost under this assistance agreement provided that the costs associated with signage are reasonable. Additionally, to increase public awareness of projects serving communities where English is not the predominant language, recipients are encouraged to translate the language on signs (excluding the official Investing in America emblem or EPA logo or seal) into the appropriate non-English language(s). The costs of such translation are allowable, provided the costs are reasonable.

## **26. Scrutinized Companies.**

- a. Grantee certifies that it is not on the Scrutinized Companies that Boycott Israel List or engaged in a boycott of Israel. Pursuant to section 287.135, F.S., the Department may immediately terminate this Agreement at its sole option if the Grantee is found to have submitted a false certification; or if the Grantee is placed on the Scrutinized Companies that Boycott Israel List or is engaged in the boycott of Israel during the term of the Agreement.
- b. If this Agreement is for more than one million dollars, the Grantee certifies that it is also not on the Scrutinized Companies with Activities in Sudan, Scrutinized Companies with Activities in the Iran Petroleum Energy Sector List, or engaged with business operations in Cuba or Syria as identified in section 287.135, F.S. Pursuant to section 287.135, F.S., the Department may immediately terminate this Agreement at its sole option if the Grantee is found to have submitted a false certification; or if the Grantee is placed on the Scrutinized Companies with Activities in Sudan List, or Scrutinized Companies with Activities in the Iran Petroleum Energy Sector List, or engaged with business operations in Cuba or Syria during the term of the Agreement.

### **Attachment 1-B**

10 of 14

- c. As provided in subsection 287.135(8), F.S., if federal law ceases to authorize these contracting prohibitions, then they shall become inoperative.

**27. Lobbying and Integrity.**

The Grantee agrees that no funds received by it under this Agreement will be expended for the purpose of lobbying the Legislature or a State agency pursuant to section 216.347, F.S., except that pursuant to the requirements of section 287.058(6), F.S., during the term of any executed agreement between Grantee and the State, Grantee may lobby the executive or legislative branch concerning the scope of services, performance, term, or compensation regarding that agreement. The Grantee shall comply with sections 11.062 and 216.347, F.S.

**28. Record Keeping.**

The Grantee shall maintain books, records and documents directly pertinent to performance under this Agreement in accordance with United States generally accepted accounting principles (US GAAP) consistently applied. The Department, the State, or their authorized representatives shall have access to such records for audit purposes during the term of this Agreement and for five (5) years following the completion date or termination of the Agreement. In the event that any work is subcontracted, Grantee shall similarly require each subcontractor to maintain and allow access to such records for audit purposes. Upon request of Department's Inspector General, or other authorized State official, Grantee shall provide any type of information the Inspector General deems relevant to Grantee's integrity or responsibility. Such information may include, but shall not be limited to, Grantee's business or financial records, documents, or files of any type or form that refer to or relate to Agreement. The Grantee shall retain such records for the longer of: (1) three years after the expiration of the Agreement; or (2) the period required by the General Records Schedules maintained by the Florida Department of State (available at: <http://dos.myflorida.com/library-archives/records-management/general-records-schedules/>).

**29. Audits.**

- a. Inspector General. The Grantee understands its duty, pursuant to section 20.055(5), F.S., to cooperate with the inspector general in any investigation, audit, inspection, review, or hearing. The Grantee will comply with this duty and ensure that its sub-grantees and/or subcontractors issued under this Agreement, if any, impose this requirement, in writing, on its sub-grantees and/or subcontractors, respectively.
- b. Physical Access and Inspection. Department personnel shall be given access to and may observe and inspect work being performed under this Agreement, with reasonable notice and during normal business hours, including by any of the following methods:
  - i. Grantee shall provide access to any location or facility on which Grantee is performing work, or storing or staging equipment, materials or documents;
  - ii. Grantee shall permit inspection of any facility, equipment, practices, or operations required in performance of any work pursuant to this Agreement; and,
  - iii. Grantee shall allow and facilitate sampling and monitoring of any substances, soils, materials or parameters at any location reasonable or necessary to assure compliance with any work or legal requirements pursuant to this Agreement.
- c. Special Audit Requirements. The Grantee shall comply with the applicable provisions contained in Attachment 5, Special Audit Requirements. Each amendment that authorizes a funding increase or decrease shall include an updated copy of Exhibit 1, to Attachment 5. If Department fails to provide an updated copy of Exhibit 1 to include in each amendment that authorizes a funding increase or decrease, Grantee shall request one from the Department's Grants Manager. The Grantee shall consider the type of financial assistance (federal and/or state) identified in Attachment 5, Exhibit 1 and determine whether the terms of Federal and/or Florida Single Audit Act Requirements may further apply to lower tier transactions that may be a result of this Agreement. For federal financial assistance, Grantee shall utilize the guidance provided under 2 CFR §200.331 for determining whether the relationship represents that of a subrecipient or vendor. For State financial assistance, Grantee shall utilize the form entitled "Checklist for Nonstate Organizations Recipient/Subrecipient vs Vendor Determination" (form number DFS-A2-NS) that can be found under the "Links/Forms" section appearing at the following website: <https://apps.fldfs.com/fsaa>.
- d. Proof of Transactions. In addition to documentation provided to support cost reimbursement as described herein, Department may periodically request additional proof of a transaction to evaluate the appropriateness of costs to the Agreement pursuant to State guidelines (including cost allocation guidelines) and federal, if applicable. Allowable costs and uniform administrative requirements for federal programs can be found under 2 CFR 200. The Department may also request a cost allocation plan in support of its multipliers (overhead, indirect, general administrative costs, and fringe benefits). The Grantee must provide the additional proof within thirty (30) days of such request.

**Attachment 1-B**

11 of 14

- e. No Commingling of Funds. The accounting systems for all Grantees must ensure that these funds are not commingled with funds from other agencies. Funds from each agency must be accounted for separately. Grantees are prohibited from commingling funds on either a program-by-program or a project-by-project basis. Funds specifically budgeted and/or received for one project may not be used to support another project. Where a Grantee's, or subrecipient's, accounting system cannot comply with this requirement, Grantee, or subrecipient, shall establish a system to provide adequate fund accountability for each project it has been awarded.
- i. If Department finds that these funds have been commingled, Department shall have the right to demand a refund, either in whole or in part, of the funds provided to Grantee under this Agreement for non-compliance with the material terms of this Agreement. The Grantee, upon such written notification from Department shall refund, and shall forthwith pay to Department, the amount of money demanded by Department. Interest on any refund shall be calculated based on the prevailing rate used by the State Board of Administration. Interest shall be calculated from the date(s) the original payment(s) are received from Department by Grantee to the date repayment is made by Grantee to Department.
  - ii. In the event that the Grantee recovers costs, incurred under this Agreement and reimbursed by Department, from another source(s), Grantee shall reimburse Department for all recovered funds originally provided under this Agreement and interest shall be charged for those recovered costs as calculated on from the date(s) the payment(s) are recovered by Grantee to the date repayment is made to Department.
  - iii. Notwithstanding the requirements of this section, the above restrictions on commingling funds do not apply to agreements where payments are made purely on a cost reimbursement basis.

**30. Conflict of Interest.**

The Grantee covenants that it presently has no interest and shall not acquire any interest which would conflict in any manner or degree with the performance of services required.

**31. Independent Contractor.**

The Grantee is an independent contractor and is not an employee or agent of Department.

**32. Subcontracting.**

- a. Unless otherwise specified in the Special Terms and Conditions, all services contracted for are to be performed solely by Grantee.
- b. The Department may, for cause, require the replacement of any Grantee employee, subcontractor, or agent. For cause, includes, but is not limited to, technical or training qualifications, quality of work, change in security status, or non-compliance with an applicable Department policy or other requirement.
- c. The Department may, for cause, deny access to Department's secure information or any facility by any Grantee employee, subcontractor, or agent.
- d. The Department's actions under paragraphs b. or c. shall not relieve Grantee of its obligation to perform all work in compliance with the Agreement. The Grantee shall be responsible for the payment of all monies due under any subcontract. The Department shall not be liable to any subcontractor for any expenses or liabilities incurred under any subcontract and Grantee shall be solely liable to the subcontractor for all expenses and liabilities incurred under any subcontract.
- e. The Department will not deny Grantee's employees, subcontractors, or agents access to meetings within the Department's facilities, unless the basis of Department's denial is safety or security considerations.
- f. The Department supports diversity in its procurement program and requests that all subcontracting opportunities afforded by this Agreement embrace diversity enthusiastically. The award of subcontracts should reflect the full diversity of the citizens of the State. A list of minority-owned firms that could be offered subcontracting opportunities may be obtained by contacting the Office of Supplier Diversity at (850) 487-0915.
- g. The Grantee shall not be liable for any excess costs for a failure to perform, if the failure to perform is caused by the default of a subcontractor at any tier, and if the cause of the default is completely beyond the control of both Grantee and the subcontractor(s), and without the fault or negligence of either, unless the subcontracted products or services were obtainable from other sources in sufficient time for Grantee to meet the required delivery schedule.

**33. Guarantee of Parent Company.**

If Grantee is a subsidiary of another corporation or other business entity, Grantee asserts that its parent company will guarantee all of the obligations of Grantee for purposes of fulfilling the obligations of Agreement. In the event Grantee is sold during the period the Agreement is in effect, Grantee agrees that it will be a requirement of sale that the new parent company guarantee all of the obligations of Grantee.

**Attachment 1-B**

12 of 14

**34. Survival.**

The respective obligations of the parties, which by their nature would continue beyond the termination or expiration of this Agreement, including without limitation, the obligations regarding confidentiality, proprietary interests, and public records, shall survive termination, cancellation, or expiration of this Agreement.

**35. Third Parties.**

The Department shall not be deemed to assume any liability for the acts, failures to act or negligence of Grantee, its agents, servants, and employees, nor shall Grantee disclaim its own negligence to Department or any third party. This Agreement does not and is not intended to confer any rights or remedies upon any person other than the parties. If Department consents to a subcontract, Grantee will specifically disclose that this Agreement does not create any third-party rights. Further, no third parties shall rely upon any of the rights and obligations created under this Agreement.

**36. Severability.**

If a court of competent jurisdiction deems any term or condition herein void or unenforceable, the other provisions are severable to that void provision, and shall remain in full force and effect.

**37. Grantee’s Employees, Subcontractors and Agents.**

All Grantee employees, subcontractors, or agents performing work under the Agreement shall be properly trained technicians who meet or exceed any specified training qualifications. Upon request, Grantee shall furnish a copy of technical certification or other proof of qualification. All employees, subcontractors, or agents performing work under Agreement must comply with all security and administrative requirements of Department and shall comply with all controlling laws and regulations relevant to the services they are providing under the Agreement.

**38. Assignment.**

The Grantee shall not sell, assign, or transfer any of its rights, duties, or obligations under the Agreement, or under any purchase order issued pursuant to the Agreement, without the prior written consent of Department. In the event of any assignment, Grantee remains secondarily liable for performance of the Agreement, unless Department expressly waives such secondary liability. The Department may assign the Agreement with prior written notice to Grantee of its intent to do so.

**39. Compensation Report.**

If this Agreement is a sole-source, public-private agreement or if the Grantee, through this agreement with the State, annually receive 50% or more of their budget from the State or from a combination of State and Federal funds, the Grantee shall provide an annual report, including the most recent IRS Form 990, detailing the total compensation for the entities' executive leadership teams. Total compensation shall include salary, bonuses, cashed-in leave, cash equivalents, severance pay, retirement benefits, deferred compensation, real-property gifts, and any other payout. The Grantee must also inform the Department of any changes in total executive compensation between the annual reports. All compensation reports must indicate what percent of compensation comes directly from the State or Federal allocations to the Grantee.

**40. Disclosure of Gifts from Foreign Sources.**

If the value of the grant under this Agreement is \$100,000 or more, Grantee shall disclose to Department any current or prior interest of, any contract with, or any grant or gift received from a foreign country of concern, as defined in section 286.101, F.S., if such interest, contract, or grant or gift has a value of \$50,000 or more and such interest existed at any time or such contract or grant or gift was received or in force at any time during the previous 5 years. Such disclosure shall include the name and mailing address of the disclosing entity, the amount of the contract or grant or gift or the value of the interest disclosed, the applicable foreign country of concern and, if applicable, the date of termination of the contract or interest, the date of receipt of the grant or gift, and the name of the agent or controlled entity that is the source or interest holder. If the disclosure requirement is applicable as described above, then within 1 year before applying for any grant, Grantee must also provide a copy of such disclosure to the Department of Financial Services.

**41. Food Commodities.**

To the extent authorized by federal law, the Department, its grantees, contractors and subcontractors shall give preference to food commodities grown or produced in this state when purchasing food commodities, including farm products as defined in section 823.14, F.S., of any class, variety, or use thereof in their natural state or as processed by a farm operation or processor for the purpose of marketing such product.

**42. Anti-human Trafficking.**

If the Grantee is a nongovernmental entity, the Grantee must provide the Department with an affidavit signed by an officer or a representative of the Grantee under penalty of perjury attesting that the Grantee does not use coercion for labor or services as defined in section 787.06, F.S.

**43. Iron and Steel for Public Works Projects.**

**Attachment 1-B**

If this Agreement funds a “public works project” as defined in section 255.0993, F.S., or the purchase of materials to be used in a public works project, any iron or steel permanently incorporated in the Project must be “produced in the United States,” as defined in section 255.0993, F.S. This requirement does not apply if the Department determines that any of the following circumstances apply to the Project:

- (1) iron or steel products produced in the United States are not produced in sufficient quantities, reasonably available, or of satisfactory quality;
- (2) the use of iron or steel products produced in the United States will increase the total cost of the project by more than twenty percent (20%); or
- (3) complying with this requirement is inconsistent with the public interest.

Further, this requirement does not prevent the Contractor’s minimal use of foreign steel and iron materials if:

- (1) such materials are incidental or ancillary to the primary product and are not separately identified in the project specifications; and
- (2) the “cost” of such materials, as defined in section 255.0993, F.S., does not exceed one-tenth of one percent (1%) of the total Project Cost under this Agreement or \$2,500, whichever is greater.

Electrical components, equipment, systems, and appurtenances, including supports, covers, shielding, and other appurtenances related to an electrical system that are necessary for operation or concealment (excepting transmission and distribution poles) are not considered to be iron or steel products and are, therefore, exempt from the requirements of this paragraph.

This provision shall be applied in a manner consistent with and may not be construed to impair the state’s obligations under any international agreement.

**44. Execution in Counterparts and Authority to Sign.**

This Agreement, any amendments, and/or change orders related to the Agreement, may be executed in counterparts, each of which shall be an original and all of which shall constitute the same instrument. In accordance with the Electronic Signature Act of 1996, electronic signatures, including facsimile transmissions, may be used and shall have the same force and effect as a written signature. Each person signing this Agreement warrants that he or she is duly authorized to do so and to bind the respective party to the Agreement.

**STATE OF FLORIDA  
DEPARTMENT OF ENVIRONMENTAL PROTECTION  
Second Revised Special Terms and Conditions  
AGREEMENT NO. 22FRP03**

**ATTACHMENT 2-B**

These Special Terms and Conditions shall be read together with general terms outlined in the Standard Terms and Conditions, Attachment 1. Where in conflict, these more specific terms shall apply.

**1. Scope of Work.**

The Project funded under this Agreement is Improving Resilience in Manatee County. The Project is defined in more detail in Attachment 3, Grant Work Plan.

**2. Duration.**

- a. Reimbursement Period. The reimbursement period for this Agreement is the same as the term of the Agreement.
- b. Extensions. There are extensions available for this Project.
- c. Service Periods. Additional service periods may be added in accordance with 2.a above and are contingent upon proper and satisfactory technical and administrative performance by the Grantee and the availability of funding.

**3. Payment Provisions.**

- a. Compensation. This is a cost reimbursement Agreement. The Grantee shall be compensated under this Agreement as described in Attachment 3.
- b. Invoicing. Invoicing will occur as indicated in Attachment 3.
- c. Advance Pay. Advance Pay is not authorized under this Agreement.

**4. Cost Eligible for Reimbursement or Matching Requirements.**

Reimbursement for costs or availability for costs to meet matching requirements shall be limited to the following budget categories, as defined in the Reference Guide for State Expenditures, as indicated:

<u>Reimbursement</u>	<u>Match</u>	<u>Category</u>
<input type="checkbox"/>	<input type="checkbox"/>	Salaries/Wages
		Overhead/Indirect/General and Administrative Costs:
<input type="checkbox"/>	<input type="checkbox"/>	a. Fringe Benefits, N/A.
<input type="checkbox"/>	<input type="checkbox"/>	b. Indirect Costs, N/A.
<input checked="" type="checkbox"/>	<input checked="" type="checkbox"/>	Contractual (Subcontractors)
<input type="checkbox"/>	<input type="checkbox"/>	Travel, in accordance with Section 112, F.S.
<input type="checkbox"/>	<input type="checkbox"/>	Equipment
<input type="checkbox"/>	<input type="checkbox"/>	Rental/Lease of Equipment
<input type="checkbox"/>	<input type="checkbox"/>	Miscellaneous/Other Expenses
<input type="checkbox"/>	<input type="checkbox"/>	Land Acquisition

**5. Equipment Purchase.**

No Equipment purchases shall be funded under this Agreement.

**6. Land Acquisition.**

There will be no Land Acquisitions funded under this Agreement.

**7. Match Requirements**

The Agreement requires at least a 47.2% match on the part of the Grantee. Therefore, the Grantee is responsible for providing \$649,000.00 through cash or third party in-kind towards the work funded under this Agreement.

The Grantee may claim allowable project expenditures made on July 1, 2021 or after for purposes of meeting its match requirement as identified above.

**Attachment 2-B**

Each payment request submitted shall document all matching funds and/or match efforts (i.e., in-kind services) provided during the period covered by each request. The final payment will not be processed until the match requirement has been met.

If, upon completion of this Project, actual Project costs are less than the total estimated Project costs, and there are no pending payment requests, the Grantee's required match may be reduced proportionately, as long as at least a 47.2% match of the actual total cost of the Project is provided by the Grantee and the reduced amount satisfies statutory and program requirements.

## **8. Insurance Requirements**

**Required Coverage.** At all times during the Agreement the Grantee, at its sole expense, shall maintain insurance coverage of such types and with such terms and limits described below. The limits of coverage under each policy maintained by the Grantee shall not be interpreted as limiting the Grantee's liability and obligations under the Agreement. All insurance policies shall be through insurers licensed and authorized to issue policies in Florida, or alternatively, Grantee may provide coverage through a self-insurance program established and operating under the laws of Florida. Additional insurance requirements for this Agreement may be required elsewhere in this Agreement, however the minimum insurance requirements applicable to this Agreement are:

a. **Commercial General Liability Insurance.**

The Grantee shall provide adequate commercial general liability insurance coverage and hold such liability insurance at all times during the Agreement. The Department, its employees, and officers shall be named as an additional insured on any general liability policies. The minimum limits shall be \$250,000 for each occurrence and \$500,000 policy aggregate.

b. **Commercial Automobile Insurance.**

If the Grantee's duties include the use of a commercial vehicle, the Grantee shall maintain automobile liability, bodily injury, and property damage coverage. Insuring clauses for both bodily injury and property damage shall provide coverage on an occurrence basis. The Department, its employees, and officers shall be named as an additional insured on any automobile insurance policy. The minimum limits shall be as follows:

\$200,000/300,000	Automobile Liability for Company-Owned Vehicles, if applicable
\$200,000/300,000	Hired and Non-owned Automobile Liability Coverage

c. **Workers' Compensation and Employer's Liability Coverage.**

The Grantee shall provide workers' compensation, in accordance with Chapter 440, F.S. and employer liability coverage with minimum limits of \$100,000 per accident, \$100,000 per person, and \$500,000 policy aggregate. Such policies shall cover all employees engaged in any work under the Grant.

d. **Other Insurance.** None.

## **9. Quality Assurance Requirements.**

There are no special Quality Assurance requirements under this Agreement.

## **10. Retainage.**

No retainage is required under this Agreement.

## **11. Subcontracting.**

The Grantee may subcontract work under this Agreement without the prior written consent of the Department's Grant Manager except for certain fixed-price subcontracts pursuant to this Agreement, which require prior approval. The Grantee shall submit a copy of the executed subcontract to the Department prior to submitting any invoices for subcontracted work. Regardless of any subcontract, the Grantee is ultimately responsible for all work to be performed under this Agreement.

## **12. State-owned Land.**

The work will not be performed on State-owned land.

## **13. Office of Policy and Budget Reporting.**

There are no special Office of Policy and Budget reporting requirements for this Agreement.

## **14. Common Carrier.**

### **Attachment 2-B**

2 of 3

- a. Applicable to contracts with a common carrier – firm/person/corporation that as a regular business transports people or commodities from place to place. If applicable, Contractor must also fill out and return PUR 1808 before contract execution. If Contractor is a common carrier pursuant to section 908.111(1)(a), Florida Statutes, the Department will terminate this contract immediately if Contractor is found to be in violation of the law or the attestation in PUR 1808.
- b. Applicable to solicitations for a common carrier – Before contract execution, the winning Contractor(s) must fill out and return PUR 1808, and attest that it is not willfully providing any service in furtherance of transporting a person into this state knowing that the person unlawfully present in the United States according to the terms of the federal Immigration and Nationality Act, 8 U.S.C. ss. 1101 et seq. The Department will terminate a contract immediately if Contractor is found to be in violation of the law or the attestation in PUR 1808.

**15. Financial Assistance and Payment of Invoices to Rural Communities or Rural Areas of Opportunity**

This agreement does not provide federal or state financial assistance to a county or municipality that is a rural community or rural area of opportunity as those terms are defined in s. 288.0656(2).

**16. Additional Terms.**

None.

*Any terms added here must be approved by the Office of General Counsel.*



**STATE OF FLORIDA  
DEPARTMENT OF ENVIRONMENTAL PROTECTION  
SECOND REVISED GRANT WORK PLAN  
AGREEMENT NO. 22FRP03**

**ATTACHMENT 3-B**

**PROJECT TITLE:** Improving Resilience in Manatee County

**PROJECT LOCATION:** The Project is located in Manatee County within Manatee County, Florida.

**PROJECT DESCRIPTION:**

Manatee County Board of County Commissioners (Grantee) will complete the Improving Resilience in Manatee County (Project), which will include development of a living shoreline (LSL) at Bishop Point Park, a public park along the tidal Manatee River considered vulnerable to climate changes (e.g., storm level rise). The Project includes design and permitting, bidding and contractor selection, and construction.

**TASKS AND DELIVERABLES**

**Task 1: Design and Permitting**

**Description:** The Grantee will procure professional services for the design and permitting of a living shoreline at Bishop Point Park and obtain all necessary permits for construction of the Project. Design and permitting activities may include coastal or civil engineering analyses, preparation of plans and specifications, physical and environmental surveys, geotechnical services, environmental analyses, orthophotography, plan formulations and other necessary studies for obtaining environmental permits and authorizations. The Grantee will submit its work products to the appropriate local, state and federal regulatory agencies.

**Deliverables:** The Grantee will submit:

- **1.1:** All final design documents as signed by a Florida-registered Professional Engineer or other applicable Florida Licensed Professional in responsible charge of the design; and
- **1.2:** A copy of final permit documents from all applicable local, state, and federal regulatory agencies for all permits required for the Project. This should include any permits listed in the original project application.

**Task 2: Bidding and Contractor Selection**

**Description:** The Grantee will procure professional services to prepare a bid package, publish a public notice, solicit bids, conduct pre-bid meetings, and respond to bidder questions in accordance with the Grantee's procurement process, as well as federal procurement regulations under 2 CFR §§200.318 through Part 200, in order to select one or more qualified and licensed contractors to complete construction of the living shoreline at Bishop Point Park.

**Deliverables:** The Grantee will submit:

- **2.1:** The public notice of advertisement for the bid;
- **2.2:** The final bid package including all inquiries, questions, comments regarding the bid; and
- **2.3:** A written notice of the selected contractor(s).

### **Task 3: Construction**

**Description:** The Grantee will construct a living shoreline at Bishop Point Park in accordance with the construction contract documents. Project costs associated with construction include work approved through construction bids and/or construction-phase engineering and monitoring service contracts. Eligible activities may include mobilization, demobilization, construction observation or inspection services, physical and environmental surveys, and mitigation projects. Construction shall be conducted in accordance with all local, state and federal permits. Project Management activities may include field engineering services, site meetings with construction contractor(s) and design professionals, and overall project coordination and supervision.

**Deliverables:** The Grantee will submit:

- **3.1:** A copy of the record (as-built) drawings;
- **3.2:** A Certificate of Completion signed by a Florida-registered Professional Engineer or authorized individual in responsible charge of project;
- **3.3:** Coordinate final site visit with Department and submit the Closeout Site Visit Form received from assigned Field Agent; and
- **3.4:** Project administration and management report(s) signed by a Florida-registered Professional Engineer or authorized individual in responsible charge of project. The report(s) must cover the performance period of the task and can be submitted no more frequently than quarterly during the performance period of the task. The report(s) must include:
  - A summary of project and site inspection(s);
  - Meeting minutes to all attended meetings; and
  - Field notes.

**PERFORMANCE MEASURES:** The Grantee will submit all deliverables for each task to the Department’s Grant Manager on or before the Task Due Date listed in the Project Timeline. The Department’s Grant Manager will review the deliverable(s) to verify that they meet the specifications in the Grant Work Plan and the task description, to include any work being performed by any subcontractor(s), and will provide written acceptance or denial of the deliverable(s) to the Grantee within thirty (30) calendar days. Tasks may include multiple deliverables to be completed. The Department will accept partial and full deliverables. Incomplete deliverables will not be accepted. A “partial deliverable” is defined as a deliverable consisting of one (1) or more (but not all) subcomponents listed in the deliverable list for a single task, where such subcomponent(s) are delivered to the Department at one hundred percent (100%) completion. A “full deliverable” is defined as a deliverable comprising all subcomponents listed in the deliverable list for a single task, all delivered to the Department at one hundred percent (100%) completion. An “incomplete deliverable” is defined as a deliverable for which one hundred percent (100%) completion has not been achieved for any of the subcomponents listed in the deliverable list for a single task. A task is considered one hundred percent (100%) complete upon the Department’s receipt and approval of all deliverable(s) listed within the task and the Department’s approval provided by the Deliverable Acceptance Letter.

**CONSEQUENCES FOR NON-PERFORMANCE:** For each task deliverable not received by the Department at one hundred percent (100%) completion and by the specified due date listed in the Agreement’s most recent Project Timeline, the Department will reduce the relevant Task Funding Amount(s) paid to Grantee in proportion to the percentage of the deliverable(s) not fully completed and/or submitted to the Department in a timely manner.

**PAYMENT REQUEST SCHEDULE:** Following the Grantee’s full or partial completion of a task’s deliverable(s) and acceptance by the Department’s Grant Manager, the Grantee may submit a payment request for cost reimbursement using the Exhibit C, Payment Request Summary Form. All payment requests must be accompanied by the Deliverable Acceptance Letter; the Exhibit A, Progress Report Form, detailing all progress made in the invoice period; and supporting fiscal documentation including match, if applicable. Interim payments will not be accepted. Payment requests will not be accepted until all required Exhibit A, Progress Report Forms, have been submitted to the Department’s Grant Manager for all reporting periods dating back to the Agreement Begin Date. Upon the Department’s receipt of the aforementioned documents and supporting fiscal documentation, the Department’s Grant Manager will have ten (10) working days to review and approve or deny the payment request.

**PROJECT TIMELINE AND BUDGET DETAIL:** The tasks must be completed by, and all deliverables received by, the corresponding task due date listed in the table below. Cost-reimbursable grant funding must not exceed the budget amounts indicated below. Requests for any change(s) must be submitted prior to the current task due date listed in the Project Timeline. Requests are to be sent via email to the Department’s Grant Manager, with the details of the request and the reason for the request made clear.

<b>Task No.</b>	<b>Task Title</b>	<b>Budget Category</b>	<b>DEP Amount</b>	<b>Match Amount</b>	<b>Total Amount</b>	<b>Task Start Date</b>	<b>Task Due Date</b>
1	Design and Permitting	Contractual Services	\$120,000	\$75,000	\$195,000	Upon Execution	09/30/2025
2	Bidding and Contractor Selection	Contractual Services	\$20,000	\$0	\$20,000	Upon Execution	3/31/2026
3	Construction	Contractual Services	\$586,000	\$574,000	\$1,160,000	Upon Execution	3/31/2027
<b>Total:</b>			<b>\$726,000</b>	<b>\$649,000</b>	<b>\$1,375,000</b>		

**STATE OF FLORIDA  
DEPARTMENT OF ENVIRONMENTAL PROTECTION  
Revised Public Records Requirements**

**Attachment 4-A**

**1. Public Records.**

- a. If the Agreement exceeds \$35,000.00, and if Grantee is acting on behalf of Department in its performance of services under the Agreement, Grantee must allow public access to all documents, papers, letters, or other material, regardless of the physical form, characteristics, or means of transmission, made or received by Grantee in conjunction with the Agreement (Public Records), unless the Public Records are exempt from section 24(a) of Article I of the Florida Constitution and section 119.07(1), F.S.
- b. The Department may unilaterally terminate the Agreement if Grantee refuses to allow public access to Public Records as required by law.

**2. Additional Public Records Duties of Section 119.0701, F.S., If Applicable.**

For the purposes of this paragraph, the term “contract” means the “Agreement.” If Grantee is a “contractor” as defined in section 119.0701(1)(a), F.S., the following provisions apply and the contractor shall:

- a. Keep and maintain Public Records required by Department to perform the service.
- b. Upon request, provide Department with a copy of requested Public Records or allow the Public Records to be inspected or copied within a reasonable time at a cost that does not exceed the cost provided in Chapter 119, F.S., or as otherwise provided by law.
- c. A contractor who fails to provide the Public Records to Department within a reasonable time may be subject to penalties under section 119.10, F.S.
- d. Ensure that Public Records that are exempt or confidential and exempt from Public Records disclosure requirements are not disclosed except as authorized by law for the duration of the contract term and following completion of the contract if the contractor does not transfer the Public Records to Department.
- e. Upon completion of the contract, transfer, at no cost, to Department all Public Records in possession of the contractor or keep and maintain Public Records required by Department to perform the service. If the contractor transfers all Public Records to Department upon completion of the contract, the contractor shall destroy any duplicate Public Records that are exempt or confidential and exempt from Public Records disclosure requirements. If the contractor keeps and maintains Public Records upon completion of the contract, the contractor shall meet all applicable requirements for retaining Public Records. All Public Records stored electronically must be provided to Department, upon request from Department’s custodian of Public Records, in a format specified by Department as compatible with the information technology systems of Department. These formatting requirements are satisfied by using the data formats as authorized in the contract or Microsoft Word, Outlook, Adobe, or Excel, and any software formats the contractor is authorized to access.

**f. IF THE CONTRACTOR HAS QUESTIONS REGARDING THE APPLICATION OF CHAPTER 119, F.S., TO THE CONTRACTOR’S DUTY TO PROVIDE PUBLIC RECORDS RELATING TO THE CONTRACT, CONTACT THE DEPARTMENT’S CUSTODIAN OF PUBLIC RECORDS AT:**

**Telephone:** (850) 245-2118  
**Email:** [public.services@floridadep.gov](mailto:public.services@floridadep.gov)  
**Mailing Address:** Department of Environmental Protection  
ATTN: Office of Ombudsman and Public Services  
Public Records Request  
3900 Commonwealth Boulevard, MS 49  
Tallahassee, Florida 32399

**Attachment 4-A**

1 of 1

**STATE OF FLORIDA  
DEPARTMENT OF ENVIRONMENTAL PROTECTION  
Second Revised Special Audit Requirements  
(State and Federal Financial Assistance)**

**Attachment 5-B**

The administration of resources awarded by the Department of Environmental Protection (*which may be referred to as the "Department", "DEP", "FDEP" or "Grantor", or other name in the agreement*) to the recipient (*which may be referred to as the "Recipient", "Grantee" or other name in the agreement*) may be subject to audits and/or monitoring by the Department of Environmental Protection, as described in this attachment.

**MONITORING**

In addition to reviews of audits conducted in accordance with 2 CFR Part 200, Subpart F-Audit Requirements, and Section 215.97, F.S., as revised (see "AUDITS" below), monitoring procedures may include, but not be limited to, on-site visits by DEP Department staff, limited scope audits as defined by 2 CFR 200.425, or other procedures. By entering into this Agreement, the recipient agrees to comply and cooperate with any monitoring procedures/processes deemed appropriate by the Department of Environmental Protection. In the event the Department of Environmental Protection determines that a limited scope audit of the recipient is appropriate, the recipient agrees to comply with any additional instructions provided by the Department to the recipient regarding such audit. The recipient further agrees to comply and cooperate with any inspections, reviews, investigations, or audits deemed necessary by the Chief Financial Officer (CFO) or Auditor General.

**AUDITS**

**PART I: FEDERALLY FUNDED**

This part is applicable if the recipient is a State or local government or a non-profit organization as defined in 2 CFR §200.330

1. A recipient that expends \$750,000 or more in Federal awards in its fiscal year, must have a single or program-specific audit conducted in accordance with the provisions of 2 CFR Part 200, Subpart F. EXHIBIT 1 to this Attachment indicates Federal funds awarded through the Department of Environmental Protection by this Agreement. In determining the federal awards expended in its fiscal year, the recipient shall consider all sources of federal awards, including federal resources received from the Department of Environmental Protection. The determination of amounts of federal awards expended should be in accordance with the guidelines established in 2 CFR 200.502-503. An audit of the recipient conducted by the Auditor General in accordance with the provisions of 2 CFR Part 200.514 will meet the requirements of this part.
2. For the audit requirements addressed in Part I, paragraph 1, the recipient shall fulfill the requirements relative to auditee responsibilities as provided in 2 CFR 200.508-512.
3. A recipient that expends less than \$750,000 in federal awards in its fiscal year is not required to have an audit conducted in accordance with the provisions of 2 CFR Part 200, Subpart F-Audit Requirements. If the recipient expends less than \$750,000 in federal awards in its fiscal year and elects to have an audit conducted in accordance with the provisions of 2 CFR 200, Subpart F-Audit

**Attachment 5-B**

1 of 7

Requirements, the cost of the audit must be paid from non-federal resources (i.e., the cost of such an audit must be paid from recipient resources obtained from other federal entities.

4. The recipient may access information regarding the Catalog of Federal Domestic Assistance (CFDA) via the internet at <https://sam.gov/content/assistance-listings>.

## **PART II: STATE FUNDED**

This part is applicable if the recipient is a nonstate entity as defined by Section 215.97(2), Florida Statutes.

1. In the event that the recipient expends a total amount of state financial assistance equal to or in excess of \$750,000 in any fiscal year of such recipient (for fiscal years ending June 30, 2017, and thereafter), the recipient must have a State single or project-specific audit for such fiscal year in accordance with Section 215.97, F.S.; Rule Chapter 69I-5, F.A.C., State Financial Assistance; and Chapters 10.550 (local governmental entities) or 10.650 (nonprofit and for-profit organizations), Rules of the Auditor General. EXHIBIT 1 to this form lists the state financial assistance awarded through the Department of Environmental Protection by this agreement. In determining the state financial assistance expended in its fiscal year, the recipient shall consider all sources of state financial assistance, including state financial assistance received from the Department of Environmental Protection, other state agencies, and other nonstate entities. State financial assistance does not include federal direct or pass-through awards and resources received by a nonstate entity for Federal program matching requirements.
2. In connection with the audit requirements addressed in Part II, paragraph 1; the recipient shall ensure that the audit complies with the requirements of Section 215.97(8), Florida Statutes. This includes submission of a financial reporting package as defined by Section 215.97(2), Florida Statutes, and Chapters 10.550 (local governmental entities) or 10.650 (nonprofit and for-profit organizations), Rules of the Auditor General.
3. If the recipient expends less than \$750,000 in state financial assistance in its fiscal year (for fiscal year ending June 30, 2017, and thereafter), an audit conducted in accordance with the provisions of Section 215.97, Florida Statutes, is not required. In the event that the recipient expends less than \$750,000 in state financial assistance in its fiscal year, and elects to have an audit conducted in accordance with the provisions of Section 215.97, Florida Statutes, the cost of the audit must be paid from the non-state entity's resources (i.e., the cost of such an audit must be paid from the recipient's resources obtained from other than State entities).
4. For information regarding the Florida Catalog of State Financial Assistance (CSFA), a recipient should access the Florida Single Audit Act website located at <https://apps.fldfs.com/fsaa> for assistance. In addition to the above websites, the following websites may be accessed for information: Legislature's Website at <http://www.leg.state.fl.us/Welcome/index.cfm>, State of Florida's website at <http://www.myflorida.com/>, Department of Financial Services' Website at <http://www.fldfs.com/> and the Auditor General's Website at <http://www.myflorida.com/audgen/>.

## **PART III: OTHER AUDIT REQUIREMENTS**

### **Attachment 5-B**

2 of 7

*(NOTE: This part would be used to specify any additional audit requirements imposed by the State awarding entity that are solely a matter of that State awarding entity's policy (i.e., the audit is not required by Federal or State laws and is not in conflict with other Federal or State audit requirements). Pursuant to Section 215.97(8), Florida Statutes, State agencies may conduct or arrange for audits of State financial assistance that are in addition to audits conducted in accordance with Section 215.97, Florida Statutes. In such an event, the State awarding agency must arrange for funding the full cost of such additional audits.)*

#### **PART IV: REPORT SUBMISSION**

1. Copies of reporting packages for audits conducted in accordance with 2 CFR Part 200, Subpart F-Audit Requirements, and required by PART I of this form shall be submitted, when required by 2 CFR 200.512, by or on behalf of the recipient directly to the Federal Audit Clearinghouse (FAC) as provided in 2 CFR 200.36 and 200.512
  - A. The Federal Audit Clearinghouse designated in 2 CFR §200.501(a) (the number of copies required by 2 CFR §200.501(a) should be submitted to the Federal Audit Clearinghouse), at the following address:

By Mail:

Federal Audit Clearinghouse  
Bureau of the Census  
1201 East 10th Street  
Jeffersonville, IN 47132

Submissions of the Single Audit reporting package for fiscal periods ending on or after January 1, 2008, must be submitted using the Federal Clearinghouse's Internet Data Entry System which can be found at <http://harvester.census.gov/facweb/>

2. Copies of financial reporting packages required by PART II of this Attachment shall be submitted by or on behalf of the recipient directly to each of the following:
  - A. The Department of Environmental Protection at one of the following addresses:

By Mail:

**Audit Director**  
Florida Department of Environmental Protection  
Office of Inspector General, MS 40  
3900 Commonwealth Boulevard  
Tallahassee, Florida 32399-3000

Electronically:

[FDEPSingleAudit@dep.state.fl.us](mailto:FDEPSingleAudit@dep.state.fl.us)

- B. The Auditor General's Office at the following address:

Auditor General  
Local Government Audits/342  
Claude Pepper Building, Room 401

#### **Attachment 5-B**

3 of 7

111 West Madison Street  
Tallahassee, Florida 32399-1450

The Auditor General's website (<http://flauditor.gov/>) provides instructions for filing an electronic copy of a financial reporting package.

3. Copies of reports or management letters required by PART III of this Attachment shall be submitted by or on behalf of the recipient directly to the Department of Environmental Protection at one of the following addresses:

By Mail:

**Audit Director**

Florida Department of Environmental Protection  
Office of Inspector General, MS 40  
3900 Commonwealth Boulevard  
Tallahassee, Florida 32399-3000

Electronically:

[FDEPSingleAudit@dep.state.fl.us](mailto:FDEPSingleAudit@dep.state.fl.us)

4. Any reports, management letters, or other information required to be submitted to the Department of Environmental Protection pursuant to this Agreement shall be submitted timely in accordance with 2 CFR 200.512, section 215.97, F.S., and Chapters 10.550 (local governmental entities) or 10.650 (nonprofit and for-profit organizations), Rules of the Auditor General, as applicable.
5. Recipients, when submitting financial reporting packages to the Department of Environmental Protection for audits done in accordance with 2 CFR 200, Subpart F-Audit Requirements, or Chapters 10.550 (local governmental entities) and 10.650 (non and for-profit organizations), Rules of the Auditor General, should indicate the date and the reporting package was delivered to the recipient correspondence accompanying the reporting package.

## **PART V: RECORD RETENTION**

The recipient shall retain sufficient records demonstrating its compliance with the terms of the award and this Agreement for a period of **five (5)** years from the date the audit report is issued, and shall allow the Department of Environmental Protection, or its designee, Chief Financial Officer, or Auditor General access to such records upon request. The recipient shall ensure that audit working papers are made available to the Department of Environmental Protection, or its designee, Chief Financial Officer, or Auditor General upon request for a period of **three (3)** years from the date the audit report is issued, unless extended in writing by the Department of Environmental Protection.



**EXHIBIT – 1**

FUNDS AWARDED TO THE RECIPIENT PURSUANT TO THIS AGREEMENT CONSIST OF THE FOLLOWING:

*Note: If the resources awarded to the recipient represent more than one federal program, provide the same information shown below for each federal program and show total federal resources awarded*

<b>Federal Resources Awarded to the Recipient Pursuant to this Agreement Consist of the Following:</b>					
<b>Federal Program A</b>	Federal Agency	CFDA Number	CFDA Title	Funding Amount	State Appropriation Category
				\$	
<b>Federal Program B</b>	Federal Agency	CFDA Number	CFDA Title	Funding Amount	State Appropriation Category
				\$	

*Note: Of the resources awarded to the recipient represent more than one federal program, list applicable compliance requirements for each federal program in the same manner as shown below:*

<b>Federal Program A</b>	First Compliance requirement: i.e.: (what services of purposes resources must be used for)	
	Second Compliance requirement: i.e.: (eligibility requirement for recipients of the resources)	
	Etc.	
	Etc.	
<b>Federal Program B</b>	First Compliance requirement: i.e.: (what services of purposes resources must be used for)	
	Second Compliance requirement: i.e.: (eligibility requirement for recipients of the resources)	
	Etc.	
	Etc.	

Note: If the resources awarded to the recipient for matching represent more than one federal program, provide the same information shown below for each federal program and show total state resources awarded for matching.

State Resources Awarded to the Recipient Pursuant to this Agreement Consist of the Following Matching Resources for Federal Programs:					
Federal Program A	Federal Agency	CFDA	CFDA Title	Funding Amount	State Appropriation Category
Federal Program B	Federal Agency	CFDA	CFDA Title	Funding Amount	State Appropriation Category

Note: If the resources awarded to the recipient represent more than one state project, provide the same information shown below for each state project and show total state financial assistance awarded that is subject to section 215.97, F.S.

State Resources Awarded to the Recipient Pursuant to this Agreement Consist of the Following Resources Subject to Section 215.97, F.S.:						
State Program A	State Awarding Agency	State Fiscal Year <sup>1</sup>	CSFA Number	CSFA Title or Funding Source Description	Funding Amount	State Appropriation Category
	Florida Department of Environmental Protection	24-25	37.098	Resilient Florida Programs	\$726,000	140065
State Program B	State Awarding Agency	State Fiscal Year <sup>2</sup>	CSFA Number	CSFA Title or Funding Source Description	Funding Amount	State Appropriation Category

Total Award	\$726,000	
-------------	-----------	--

Note: List applicable compliance requirement in the same manner as illustrated above for federal resources. For matching resources provided by the Department for DEP for federal programs, the requirements might be similar to the requirements for the applicable federal programs. Also, to the extent that different requirements pertain to different amount for the non-federal resources, there may be more than one grouping (i.e. 1, 2, 3, etc.) listed under this category.

For each program identified above, the recipient shall comply with the program requirements described in the Catalog of Federal Domestic Assistance (CFDA) [<https://sam.gov/content/assistance-listings>] and/or the Florida Catalog of State Financial Assistance (CSFA) [<https://apps.fldfs.com/fsaa/searchCatalog.aspx>], and State Projects Compliance Supplement (Part Four: State Projects Compliance Supplement [[https://apps.fldfs.com/fsaa/state\\_project\\_compliance.aspx](https://apps.fldfs.com/fsaa/state_project_compliance.aspx)]). The

<sup>1</sup> Subject to change by Change Order.

<sup>2</sup> Subject to change by Change Order.

services/purposes for which the funds are to be used are included in the Agreement's Grant Work Plan. Any match required by the Recipient is clearly indicated in the Agreement.

**Attachment 5-B, Exhibit 1**  
7 of 7

**STATE OF FLORIDA  
DEPARTMENT OF ENVIRONMENTAL PROTECTION  
REVISED PROGRAM-SPECIFIC REQUIREMENTS  
RESILIENT FLORIDA PROGRAM**

**ATTACHMENT 6-A**

**General**

1. Deliverable and Payment Request Submissions. All grant deliverables and payment requests (Exhibit C) must be submitted to [ResilientFloridaGrants@FloridaDEP.gov](mailto:ResilientFloridaGrants@FloridaDEP.gov).
2. Contractual Services. For all grant agreements that include Contractual Services as an expenditure category, the Grantee must submit Exhibit H, Contractual Services Certification, and all required supporting documentation for all contractors conducting work under the grant agreement, prior to submitting a payment request for contractual services.
3. Grantee Match Form. If the grant agreement includes match requirements in Attachment 2, the Grantee must submit the Grantee Match Form upon execution of the grant agreement and at any time there are changes to the match funding amount and/or funding source throughout the grant agreement period.
4. Project Photos. The Grantee must submit Exhibit G, Photo Release Form, with the first submission of deliverables and reports (Exhibit A and F) that include photos.
5. DEP Logo and Funding Source Disclaimer. The final Vulnerability Assessment Report, Adaptation Plan report or document, and any permanent signage created for an implementation project included on the Statewide Flooding and Sea Level Rise Resilience Plan must include the Department's logo (which can be found on the Department's website at: <https://floridadep.gov> or by contacting the Grant Manager for a copy) as well as the following language:

“This work was funded in part through a grant agreement from the Florida Department of Environmental Protection’s Office of Resilience and Coastal Protection Resilient Florida Program. The views, statements, findings, conclusions, and recommendations expressed herein are those of the author(s) and do not necessarily reflect the views of the State of Florida or any of its subagencies.”

6. Final Project Report. The Grantee must submit Exhibit F, Final Project Report Form, prior to requesting final payment. The Final Project Report may be submitted in lieu of the final quarterly status report, only in instances where the next quarterly report falls after the project’s completion date. For projects that are not completed by the Agreement End Date, Exhibit F must be submitted to [ResilientFloridaGrants@FloridaDEP.gov](mailto:ResilientFloridaGrants@FloridaDEP.gov) upon completion of the project, which may be after the Agreement End Date.
7. Copyright, Patent and Trademark. The Department reserves a royalty-free, nonexclusive, and irrevocable license to reproduce, publish or otherwise use, and to authorize others to use, for state government purposes:
  - a. The copyright in any work developed under this Agreement; and
  - b. Any rights or copyright to which the Grantee or subcontractor purchases ownership with grant support.
8. State and Local Fiscal Recovery Funds. For all grant agreements funded with the Coronavirus State and Local Fiscal Recovery Funds (SLFRF) under the American Rescue Plan Act, the Grantee must submit the SLFRF Reporting Requirements Form upon execution of the grant agreement.
9. Geographic Information System (GIS) files and associated metadata. All GIS files and associated metadata

must adhere to the Resilient Florida Program’s GIS Data Standards (found on the Resilient Florida Program website: <https://floridadep.gov/rcp/resilient-florida-program/documents/resilient-florida-program-gis-data-standards>), and raw data sources shall be defined within the associated metadata.

### **Implementation Grants**

10. Sea Level Impact Projection Study Requirement. If a state-funded construction project is located within an area where a Sea Level Impact Protection (SLIP) study is required pursuant to Section 380.0937, Florida Statutes, the Grantee is responsible for conducting such a SLIP study and submitting the resulting report to the Department. The SLIP study report must be received by the Department, approved by the Department, and published on the Department’s website for at least thirty (30) days before construction can commence. Upon submission to the Department, SLIP study reports must meet all relevant statutory requirements, as well as the standards and criteria indicated in Chapter 62S-7, Florida Administrative Code.
11. Permits. The Grantee acknowledges that receipt of this grant does not imply nor guarantee that a federal, state, or local permit will be issued for a particular activity. The Grantee agrees to ensure that all necessary permits are obtained prior to implementation of any grant-funded activity that may fall under applicable federal, state, or local laws. Further, the Grantee shall abide by all terms and conditions of each applicable permit for any grant-funded activity. Upon request, the Grantee must provide a copy of all required, acquired, and approved permits for the project.
12. Grant funds may not be used to support ongoing efforts to comply with certain legal requirements or actions that were unanticipated, non-existent, or unknown to the Department at the time of this Agreement’s execution, including regulatory and permit compliance requirements, non-compliance and citation fees, fees resulting from unanticipated permit conditions, settlement agreements, and compliance with formal or informal enforcement actions to resolve violations of applicable rules and statutes (including consent orders, Closed Without Official Enforcement agreements, and similar enforcement actions). Grant funds may be utilized to support ongoing efforts to comply with permit-required conditions, as approved by the Resilient Florida Program (e.g., pre-, during-, and post-construction monitoring and mitigation efforts).

**ATTACHMENT 8-A**  
**Revised Contract Provisions for Coronavirus State and Local Fiscal**  
**Recovery Funds**  
**(SLFRF) Agreements**

The Department, as a Non-Federal Entity as defined by 2 CFR §200.69, shall comply with the following provisions, where applicable. For purposes of this Grant Agreement between the Department and the Grantee, the term “Recipient” shall mean “Grantee.”

Further, the Department, as a pass-through entity, also requires the Grantee to pass on these requirements to all lower tier subrecipients/contractors, and to comply with the provisions of the award, the SLFRF implementing regulation, including applicable provisions of the OMB Uniform Guidance (2 CFR Part 200), and all associated terms and conditions. Therefore, Grantees must include these requirements in all related subcontracts and/or sub-awards. Grantees can include these requirements by incorporating this Attachment in the related subcontract and/or sub-awards, however for all such subcontracts and sub-awards, the Grantee shall assume the role of the Non-Federal Entity and the subrecipients shall assume the role of the Recipient.

**2 CFR PART 200 APPENDIX 2 REQUIREMENTS**

**1. Administrative, Contractual, and Legal Remedies**

The following provision is required if the Agreement is for more than \$150,000. In addition to any of the remedies described elsewhere in the Agreement, if the Recipient materially fails to comply with the terms and conditions of this Contract, including any Federal or State statutes, rules, or regulations, applicable to this Contract, the Non-Federal Entity may take one or more of the following actions.

- A. Temporarily withhold payments pending correction of the deficiency by the Recipient.
- B. Disallow (that is, deny both use of funds and any applicable matching credit for) all or part of the cost of the activity or action not in compliance.
- C. Wholly or partly suspend or terminate this Contract.
- D. Take other remedies that may be legally available.

The remedies identified above, do not preclude the Recipient from being subject to debarment and suspension under Presidential Executive Orders 12549 and 12689. The Non-Federal entity shall have the right to demand a refund, either in whole or part, of the funds provided to the Recipient for noncompliance with the terms of this Agreement.

**2. Termination for Cause and Convenience**

Termination for Cause and Convenience are addressed elsewhere in the Agreement.

**3. Equal Opportunity Clause**

The following provision applies if the agreement meets the definition of “federally assisted construction contract” as defined by 41 CFR Part 60-1.3:

During the performance of this Agreement, the Recipient agrees as follows:

- A. The Recipient will not discriminate against any employee or applicant for employment because of race, color, religion, sex, sexual orientation, gender identity, or national origin. The Recipient will take affirmative action to ensure that applicants are employed, and that employees are treated during employment without regard to their race, color, religion, sex, sexual orientation, gender identity, or national origin. Such action shall include, but not be limited to the following:
  - i. Employment, upgrading, demotion, or transfer; recruitment or recruitment advertising; layoff or termination; rates of pay or other forms of compensation; and selection for training, including apprenticeship. The Recipient agrees to post in conspicuous places, available to employees and applicants for employment, notices to be provided setting forth the provisions of this nondiscrimination clause.
- B. The Recipient will, in all solicitations or advertisements for employees placed by or on behalf of the Recipient, state that all qualified applicants will receive consideration for employment without regard to race, color, religion, sex, sexual orientation, gender identity, or national origin.
- C. The Recipient will not discharge or in any other manner discriminate against any employee or applicant for employment because such employee or applicant has inquired about, discussed, or disclosed the compensation of the employee or applicant or another employee or applicant. This provision shall not apply to instances in which an employee who has access to the compensation information of other employees or applicants as a part of such employee's

**Attachment 8-A**

1 of 6

essential job functions discloses the compensation of such other employees or applicants to individuals who do not otherwise have access to such information, unless such disclosure is in response to a formal complaint or charge, in furtherance of an investigation, proceeding, hearing, or action, including an investigation conducted by the employer, or is consistent with the Recipient's legal duty to furnish information.

- D. The Recipient will send to each labor union or representative of workers with which he has a collective bargaining agreement or other Agreement or understanding, a notice to be provided advising the said labor union or workers' representatives of the Recipient's commitments under this section, and shall post copies of the notice in conspicuous places available to employees and applicants for employment.
- E. The Recipient will comply with all provisions of Executive Order 11246 of September 24, 1965, and of the rules, regulations, and relevant orders of the Secretary of Labor.
- F. The Recipient will furnish all information and reports required by Executive Order 11246 of September 24, 1965, and by rules, regulations, and orders of the Secretary of Labor, or pursuant thereto, and will permit access to his books, records, and accounts by the administering agency and the Secretary of Labor for purposes of investigation to ascertain compliance with such rules, regulations, and orders.
- G. In the event of the Recipient's noncompliance with the nondiscrimination clauses of this Agreement or with any of the said rules, regulations, or orders, this Agreement may be canceled, terminated, or suspended in whole or in part and the Recipient may be declared ineligible for further Government contracts or federally assisted construction contracts in accordance with procedures authorized in Executive Order 11246 of September 24, 1965, and such other sanctions may be imposed and remedies invoked as provided in Executive Order 11246 of September 24, 1965, or by rule, regulation, or order of the Secretary of Labor, or as otherwise provided by law.
- H. The Recipient will include the portion of the sentence immediately preceding paragraph (1) and the provisions of paragraphs (1) through (8) in every subcontract or purchase order unless exempted by rules, regulations, or orders of the Secretary of Labor issued pursuant to section 204 of Executive Order 11246 of September 24, 1965, so that such provisions will be binding upon each subcontractor or vendor. The Recipient will take such action with respect to any subcontractor purchase order as the administering agency may direct as a means of enforcing such provisions, including sanctions for noncompliance.

#### 4. Contract Work Hours and Safety Standards Act

Where applicable, if the Agreement is in excess of \$100,000 and involves the employment of mechanics or laborers, the Recipient must comply with 40 U.S.C. 3702 and 3704, as supplemented by Department of Labor regulations (29 CFR Part 5). Under 40 U.S.C. 3702 of the Act, each Recipient must be required to compute the wages of every mechanic and laborer on the basis of a standard work week of 40 hours. Work in excess of the standard work week is permissible provided that the worker is compensated at a rate of not less than one and a half times the basic rate of pay for all hours worked in excess of 40 hours in the work week. The requirements of 40 U.S.C. 3704 are applicable to construction work and provide that no laborer or mechanic must be required to work in surroundings or under working conditions which are unsanitary, hazardous, or dangerous. These requirements do not apply to the purchases of supplies or materials or articles ordinarily available on the open market, or contracts for transportation or transmission of intelligence.

#### 5. Rights to Inventions Made Under Agreement

If the Federal award meets the definition of "funding agreement" under 37 CFR §401.2 (a) and the Non-Federal Entity or subrecipient wishes to enter into a contract with a small business firm or nonprofit organization regarding the substitution of parties, assignment or performance of experimental, developmental, or research work under that "funding agreement," the Non-Federal Entity or subrecipient must comply with the requirements of 37 CFR Part 401, "Rights to Inventions Made by Nonprofit Organizations and Small Business Firms Under Government Grants, Contracts and Cooperative Agreements," and any implementing regulations issued by the awarding agency.

#### 6. Clean Air Act (42 U.S.C. 7401-7671q.), the Federal Water Pollution Control Act (33 U.S.C. 1251-1387), and EPA Regulations

If the Agreement is in excess of \$100,000, the Recipient shall comply with all applicable standards, orders or regulations issued pursuant to the Clean Air Act (42 U.S.C. 7401-7671q) and the Federal Water Pollution Control

### Attachment 8-A

Act as amended (33 U.S.C. 1251-1387), and by the EPA (40 CFR Part 15). Violations must be reported to the Federal Awarding Agency and the Regional Office of the Environmental Protection Agency (EPA).

- i. The Grantee shall include these requirements for the Clean Air Act and the Federal Water Pollution Act in each subcontract exceeding \$100,000 financed in whole or in part with SLFRF funds.

7. Debarment and Suspension (Executive Orders 12549 and 12689)

The Recipient certifies that it is not listed on the governmentwide exclusions in the System for Award Management (SAM), in accordance with the OMB guidelines at 2 CFR 180 and 2 CF 1200 that implement Executive Orders 12549 (3 CFR part 1986 Comp., p. 189) and 12689 (3 CFR part 1989 Comp., p. 235), “Debarment and Suspension.”

8. Byrd Anti-Lobbying Amendment (31 U.S.C. 1352)

The Recipient certifies that it will not and has not used Federal appropriated funds to pay any person or organization for influencing or attempting to influence an officer or employee of any agency, a member of Congress, officer or employee of Congress, or an employee of a member of Congress in connection with obtaining any Federal contract, grant or any other award covered by 31 U.S.C. 1352. If applicable, the Recipient shall disclose any lobbying with non-Federal funds that takes place in connection with obtaining any Federal award, using form SF-LLL, available at:

[https://apply07.grants.gov/apply/forms/sample/SFLLL\\_1\\_2\\_P-V1.2.pdf](https://apply07.grants.gov/apply/forms/sample/SFLLL_1_2_P-V1.2.pdf).

- i. Grantees who apply or bid for an award of \$100,000 or more shall file the required certification. Each tier certifies to the tier above that it will not and has not used federal appropriated funds to pay any person or organization for influencing or attempting to influence an officer or employee of any agency, a member of Congress, officer or employee of Congress, or an employee of a member of Congress in connection with obtaining any federal contract, grant, or any other award covered by 31 U.S.C. § 1352. Each tier shall also disclose any lobbying with non-federal funds that takes place in connection with obtaining any federal award. Such disclosures are forwarded from tier to tier, up to the recipient.

9. Procurement of Recovered Materials

The Recipient must comply with Section 6002 of the Solid Waste Disposal Act, as amended by the Resource Conservation and Recovery Act as described in 2 CFR part 200.322.

10. Prohibition on Certain Telecommunications and Video Surveillance Services or Equipment

The Recipients and subrecipients are prohibited from obligating or expending loan or grant funds to procure or obtain; extend or renew a contract to procure or obtain; or enter into a contract (or extend or renew a contract) to procure or obtain equipment, services, or systems that uses covered telecommunications equipment or services as a substantial or essential component of any system, or as critical technology as part of any system. See Section 889 of Public Law 115-232 (National Defense Authorization Act 2019). Also, see 2 CFR 200.216 and 200.471.

11. Domestic Preferences for Procurement

The Recipients and subrecipients must, to the greatest extent practical, give preference to the purchase, acquisition, or use of goods, products, or materials produced in the United States in accordance with 2 CFR 200.322.

**ADMINISTRATIVE**

1. General Federal Regulations

Recipients shall comply with the regulations listed in 2 CFR 200, 48 CFR 31, and 40 U.S.C. 1101 *et seq.*

2. Rights to Patents and Inventions Made Under a Contract or Agreement

Rights to inventions made under this assistance agreement are subject to federal patent and licensing regulations, which are codified at Title 37 CFR Part 401 and Title 35 U.S.C. 200 through 212.

3. Compliance with the Trafficking Victims Protection Act of 2000 (2 CFR Part 175)

Recipients, their employees, subrecipients under this award, and subrecipients' employees may not:

- A. Engage in severe forms of trafficking in persons during the period of time that the award is in effect;
- B. Procure a commercial sex act during the period of time that the award is in effect; or
- C. Use forced labor in the performance of the award or subawards under the award.

4. Whistleblower Protection

Recipients shall comply with U.S.C. §4712, Enhancement of Recipient and Subrecipient Employee Whistleblower Protection. This requirement applies to all awards issued after July 1, 2013 and effective December 14, 2016 has been permanently extended (Public Law (P.L.) 114-261).

**Attachment 8-A**

3 of 6



- A. This award, related subawards, and related contracts over the simplified acquisition threshold and all employees working on this award, related subawards, and related contracts over the simplified acquisition threshold are subject to the whistleblower rights and remedies in the pilot program on award recipient employee whistleblower protections established at 41 U.S.C. 4712 by section 828 of the National Defense Authorization Act for Fiscal Year 2013 (P.L. 112-239).
- B. Recipients, their subrecipients, and their contractors awarded contracts over the simplified acquisition threshold related to this award, shall inform their employees in writing, in the predominant language of the workforce, of the employee whistleblower rights and protections under 41 U.S.C. 4712.
- C. The Recipient shall insert this clause, including this paragraph C, in all subawards and in contracts over the simplified acquisition threshold related to this award; best efforts should be made to include this clause, including this paragraph C in any subawards and contracts awarded prior to the effective date of this provision.

5. Notification of Termination (2 CFR § 200.340)

In accordance with 2 CFR § 200.340, in the event that the Agreement is terminated prior to the end of the period of performance due to the Recipient’s or subcontractor’s material failure to comply with Federal statutes, regulations or the terms and conditions of this Agreement or the Federal award, the termination shall be reported to the Office of Management and Budget (OMB)-designated integrity and performance system, accessible through System for Award Management (SAM) currently the Federal Awardee Performance and Integrity Information System (FAPIIS). The Non-Federal Entity will notify the Recipient of the termination and the Federal requirement to report the termination in FAPIIS. See 2 CFR § 200.340 for the requirements of the notice and the Recipient’s rights upon termination and following termination.

6. Additional Lobbying Requirements

- A. The Recipient certifies that no funds provided under this Agreement have been used or will be used to engage in the lobbying of the Federal Government or in litigation against the United States unless authorized under existing law.
- B. The Lobbying Disclosure Act of 1995, as amended (2 U.S.C. §1601 et seq.), prohibits any organization described in Section 501(c)(4) of the Internal Revenue Code, from receiving federal funds through an award, grant (and/or subgrant) or loan unless such organization warrants that it does not, and will not engage in lobbying activities prohibited by the Act as a special condition of such an award, grant (and/or subgrant), or loan. This restriction does not apply to loans made pursuant to approved revolving loan programs or to contracts awarded using proper procurement procedures.
- C. Pursuant to 2 CFR §200.450 and 2 CFR §200.454(e), the Recipient is hereby prohibited from using funds provided by this Agreement for membership dues to any entity or organization engaged in lobbying activities.

7. Increasing Seat Belt Use in the United States

Pursuant to Executive Order 13043, 62 FR 19217 (Apr. 18, 1997), Grantee is encouraged to adopt and enforce on-the-job seat belt policies and programs for its employees when operating company-owned, rented or personally owned vehicles.

8. Reducing Text Messaging While Driving

Pursuant to Executive Order 13513, 74 FR 51225 (Oct. 6, 2009), Grantee is encouraged to adopt and enforce policies that ban text messaging while driving and establish workplace safety policies to decrease accidents caused by distracted drivers.

9. Uniform Relocation Assistance and Real Property Acquisitions Act of 1970

Where applicable, 42 U.S.C. §§ 4601-4655 and implementing regulations apply to this Agreement.

**COMPLIANCE WITH ASSURANCES**

1. Assurances

Recipients shall comply with all applicable assurances made by the Department or the Recipient to the Federal Government during the Grant application process.

**FEDERAL REPORTING REQUIREMENTS**

1. FFATA

Grant Recipients awarded a new Federal grant greater than or equal to \$30,000 awarded on or after October 1, 2015, are subject to the FFATA the Federal Funding Accountability and Transparency Act (“FFATA”) of 2006. The FFATA legislation requires that information on federal awards (federal financial assistance and expenditures) be made available to the public via a single, searchable website, which is [www.USASpending.gov](http://www.USASpending.gov).

**Attachment 8-A**

The Grantee agrees to provide the information necessary, within one (1) month of execution, for the Department to comply with this requirement.

**DEPARTMENT OF TREASURY-SPECIFIC**

**1. Civil Rights Compliance**

Recipients of Federal financial assistance from the Treasury are required to meet legal requirements relating to nondiscrimination and nondiscriminatory use of Federal funds. Those requirements include ensuring that entities receiving Federal financial assistance from the Treasury do not deny benefits or services or otherwise discriminate on the basis of race, color, national origin, (including limited English proficiency), disability, age, or sex (including sexual orientation and gender identity), in accordance with the following: Title VI of Civil Rights Acts of 1973 (Section 504), Public Law 93-112, as amended by Public Law 93-516, 29 U.S.C. 794; Title IX of the Education Amendments of 1972 (Title IX), 20 U.S.C. 1681 et seq., and the Department’s implementing regulations, 31 CFR 28; Age Discrimination Act of 1975, Public Law 94-135, 42 U.S.C. 6101 et seq., and the Department of Treasury implementing regulations at 31 CFR part 23.

The Department of Treasury will request information on recipients’ compliance with Title VI of the Civil Rights Act of 1964, as applicable, on an annual basis. This information may include a narrative describing the recipient’s compliance with Title VI, along with other questions and assurances.

**SLFRF-SPECIFIC**

**1. Period of Performance**

The Department must obligate all funds from SLFRF by December 31, 2024, and all such obligated funds must be expended by December 31, 2026. As such, the Contractor must submit all invoices by September 30, 2026, unless approved in writing by the Department.

**2. Equipment and Real Property Management**

Any purchase of equipment or real property with SLFRF funds must be consistent with the Uniform Guidance at 2 CFR Part 200, Subpart D. Equipment and real property acquired under this program must be used for the originally authorized purpose. Consistent with 2 CFR 200.311 and 2 CFR 200.313, any equipment or real property acquired using SLFRF funds shall vest in the non-Federal entity. Any acquisition and maintenance of equipment or real property must also be in compliance with relevant laws and regulations.

**SLFRF INFRASTRUCTURE PROJECTS**

For all infrastructure projects, the Grantee shall provide the following project information on a quarterly basis to the Department:

- i. Projected/actual construction start date (month/year)
- ii. Projected/actual initiation of operation date (month/year)
- iii. Location details

**SLFRF INFRASTRUCTURE PROJECTS OVER \$10 MILLION**

For infrastructure projects over \$10 million, the following provisions apply:

**1. Wage Certification**

Grantees may provide a certification that all laborers and mechanics employed by Grantee in the performance of such project are paid wages at the rates not less than those prevailing, as determined by the U.S. Secretary of Labor in accordance with the Davis-Bacon Act, for the corresponding classes of laborers and mechanics employed projected of a character similar to the contract work in the civil subdivision of Florida in which the work is to be performed. If the Grantee does not provide such certification, the Grantee must provide a project employment and local impact report detailing:

- i. The number of employees of contractors and sub-contractors working on the project;
- ii. The number of employees on the project hired directly and hired through a third party;
- iii. The wages and benefits of workers on the project by classification; and
- iv. Whether those wages are at rates less than those prevailing.

Grantee must maintain sufficient records to substantiate this information upon request.

**2. Project Labor Agreements**

Grantees may provide a certification that the project includes a project labor agreement, meaning a pre-hire

collective bargaining agreement consistent with the section 8(f) of the National Labor Relations Act (29 U.S.C. 158(f)). If the Grantee does not provide such certification, the Grantee must provide a project workforce continuity plan, detailing:

- i. How the Grantee will ensure the project has ready access to a sufficient supply of appropriately skilled and unskilled labor to ensure high-quality construction throughout the life of the project;
  - ii. How the Grantee will minimize risks of labor disputes and disruptions that would jeopardize timeliness and cost-effectiveness of the project;
  - iii. How the Grantee will provide a safe and healthy workplace that avoids delays and costs associated with workplace illnesses, injuries, and fatalities;
  - iv. Whether workers on the project will receive wages and benefits that will secure and appropriately skilled workforce in the context of the local or regional labor market; and
  - v. Whether the project has completed a labor agreement.
3. Other Reporting Requirements

Grantees must report whether the project prioritizes local hires and whether the project has Community Benefit Agreement, with a description of any such agreement, if applicable.

### **SLFRF WATER & SEWER PROJECTS**

For water and sewer projects, Grantees shall provide the following information to the Department once the project starts, as applicable:

- i. National Pollutant Discharge Elimination System (NPDES) Permit Number, for projects aligned with the Clean Water State Revolving Fund
- ii. Public Water System (PWS) ID number, for projects aligned with the Drinking Water State Revolving Fund.

## **MANATEE COUNTY – SPECIAL PROVISIONS – FEDERAL GRANTS – TERMS AND CONDITIONS**

### **CONTRACT PROVISIONS FOR NON-FEDERAL ENTITY CONTRACTS UNDER FEDERAL AWARDS**

In addition to other provisions required, all contracts made by the County that are funded in whole, or in part, by a Federal grant the following provisions will apply:

#### **A. Termination for Cause**

1. COUNTY shall have the right, by written notice to CONTRACTOR, to terminate this Agreement, in whole or in part, for failure to substantially comply with the terms and conditions of this Agreement (Work Assignments, if applicable), to include:
  - a. Failure to provide the Work that comply with the specifications herein or that fail to meet COUNTY'S performance standards;
  - b. Failure to deliver or perform the Work within the time specified in the agreement; or
  - c. Progress that is at a rate that disrupts the overall performance of this Agreement.
2. Prior to termination for default, COUNTY shall provide adequate written notice to CONTRACTOR, affording CONTRACTOR the opportunity to cure the deficiencies or to submit a specific plan to resolve the deficiencies within ten (10) days (or the period specified in the notice) after receipt of the notice. Failure to adequately cure the deficiency shall result in termination action.
3. Such termination may also result in suspension or debarment of CONTRACTOR in accordance with Manatee County's Procurement Ordinance, Chapter 2-26. CONTRACTOR shall be liable for any damage to COUNTY resulting from CONTRACTOR'S default of the Agreement.
4. In the event of termination of this Agreement, CONTRACTOR shall be liable for any damage to COUNTY resulting from CONTRACTOR'S default of this Agreement. This liability includes any increased costs incurred by COUNTY in completing performance under this Agreement.
5. In the event of termination by COUNTY for any cause, CONTRACTOR shall not have any right or claim against COUNTY for lost profits or compensation for lost opportunities. After a receipt of COUNTY'S Notice of Termination and except as otherwise directed by COUNTY, CONTRACTOR shall:
  - a. Stop the Work on the date and to the extent specified;
  - b. Terminate and settle all orders and subcontracts relating to the performance of the terminated Work;
  - c. Transfer all work in process, completed Work, and other materials related to the terminated Work as directed by COUNTY; and
  - d. Continue and complete all parts of the Work that have not been terminated.

## **B. Termination for Convenience**

COUNTY may terminate this Agreement, in whole or in part, or individual Work Assignments without cause. COUNTY shall provide CONTRACTOR a written “Notice of Intent to Terminate” thirty (30) days prior to the date of termination. If this Agreement is terminated by the COUNTY without cause, CONTRACTOR shall be entitled to payment for all Work performed to the satisfaction of the COUNTY and all expenses incurred under this Agreement prior to termination, less any costs, expenses or damages due to the failure of the CONTRACTOR to properly perform pursuant to this Agreement. CONTRACTOR shall not be entitled to any other compensation, including anticipated profits on unperformed Work.

## **C. Equal Opportunity Employment**

In accordance with 41 C.F.R. §60-1.4(b), the County hereby agrees that it will incorporate or cause to be incorporated into any contract for construction work, or modification thereof, as defined in the regulations of the Secretary of Labor at 41 CFR Chapter 60, which is paid for in whole or in part with funds obtained from the Federal Government or borrowed on the credit of the Federal Government pursuant to a grant, contract, loan, insurance, or guarantee, or undertaken pursuant to any Federal program involving such grant, contract, loan, insurance, or guarantee, the following equal opportunity clause:

During the performance of this contract, the contractor agrees as follows:

The contractor will not discriminate against any employee or applicant for employment because of race, color, religion, sex, sexual orientation, gender identity, or national origin. The contractor will take affirmative action to ensure that applicants are employed, and that employees are treated during employment without regard to their race, color, religion, sex, sexual orientation, gender identity, or national origin. Such action shall include, but not be limited to the following:

- i. Employment, upgrading, demotion, or transfer; recruitment or recruitment advertising; layoff or termination; rates of pay or other forms of compensation; and selection for training, including apprenticeship. The contractor agrees to post in conspicuous places, available to employees and applicants for employment, notices to be provided setting forth the provisions of this nondiscrimination clause.
- ii. The contractor will, in all solicitations or advertisements for employees placed by or on behalf of the contractor, state that all qualified applicants will receive considerations for employment without regard to race, color, religion, sex, sexual orientation, gender identity, or national origin.
- iii. The contractor will not discharge or in any other manner discriminate against any employee or applicant for employment because such employee or applicant has inquired about, discussed, or disclosed the compensation of the employee or applicant or another employee or applicant. This provision shall not apply to instances in which an employee

who has access to the compensation information of other employees or applicants as a part of such employee's essential job functions discloses the compensation of such other employees or applicants to individuals who do not otherwise have access to such information, unless such disclosure is in response to a formal complaint or charge, in furtherance of an investigation, proceeding, hearing, or action, including an investigation conducted by the employer, or is consistent with the contractor's legal duty to furnish information.

- iv. The contractor will send to each labor union or representative of workers with which he has a collective bargaining agreement or other contract or understanding, a notice to be provided advising the said labor union or workers' representatives of the contractor's commitments under this section and shall post copies of the notice in conspicuous places available to employees and applicants for employment.
- v. The contractor will comply with all provisions of Executive Order 11246 of September 24, 1965, and of the rules, regulations, and relevant orders of the Secretary of Labor.
- vi. The contractor will furnish all information and reports required by Executive Order 11246 of September 24, 1965, and by rules, regulations, and orders of the Secretary of Labor, or pursuant thereto, and will permit access to his books, records, and accounts by the administering agency and the Secretary of Labor for purposes of investigation to ascertain compliance with such rules, regulations, and orders.
- vii. In the event of the contractor's noncompliance with the nondiscrimination clauses of this contract or with any of the said rules, regulations, or orders, this contract may be canceled, terminated, or suspended in whole or in part and the contractor may be declared ineligible for further Government contracts or federally assisted construction contracts in accordance with procedures authorized in Executive Order 11246 of September 24, 1965, and such other sanctions may be imposed and remedies invoked as provided in Executive Order 11246 of September 24, 1965, or by rule, regulation, or order of the Secretary of Labor, or as otherwise provided by law.
- viii. The contractor will include the portion of the sentence immediately preceding paragraph (1) and the provisions of paragraphs (1) through (8) in every subcontract or purchase order unless exempted by rules, regulations, or orders of the Secretary of Labor issued pursuant to section 204 of Executive Order 11246 of September 24, 1965, so that such provisions will be binding upon each subcontractor or vendor. The contractor will take such action with respect to any subcontract or purchase order as the administering agency may direct as a means of enforcing such provisions, including sanctions for noncompliance:

Provided, however, that in the event a contractor becomes involved in, or is threatened with, litigation with a subcontractor or vendor as a result of such direction by the administering agency the contractor may request the United States to enter into such litigation to protect the interests of the United States.

**D. Contract Work Hours and Safety Standards Act (40 U.S.C. 3701–3708)**

To the extent applicable, Contractor agrees to comply with 40 U.S.C. 3702 and 3704, as supplemented by Department of Labor regulations (29 CFR Part 5). Under 40 U.S.C. 3702 of the Act. Contractor must compute the wages of every mechanic and laborer based on a standard work week of 40 hours.

Work in excess of the standard work week is permissible provided that the worker is compensated at a rate of not less than one and a half times the basic rate of pay for all hours worked in excess of 40 hours in the workweek. The requirements of 40 U.S.C. 3704 are applicable to construction work and provide that no laborer or mechanic must be required to work in surroundings or underworking conditions which are unsanitary, hazardous or dangerous.

NOTE: These requirements do not apply to the purchases of supplies or materials or articles ordinarily available on the open market, or contracts for transportation or transmission of intelligence.

**E. Clean Air Act (42 U.S.C. 7401–7671q.) and the Federal Water Pollution Control Act (33U.S.C. 1251–1387), as amended**

To the extent possible, Contractor agrees to comply with all applicable standards, orders or regulations issued pursuant to the Clean Air Act (42 U.S.C. 7401–7671q) and the Federal Water Pollution Control Act as amended (33 U.S.C.1251–1387). Contractor shall report all violations of such Acts to the Federal awarding agency and the Regional Office of the Environmental Protection Agency (EPA).

**F. Suspension and Debarment (Executive Orders 12549 and 12689)**

Contractor states that Contractor is not listed on the government-wide exclusions in the federal government’s System for Award Management (SAM). Such listing would prevent performance of this Agreement in accordance with the OMB guidelines at 2 CFR 180 that implement Executive Orders 12549 (3 CFR part 1986 Comp., p. 189) and 12689 (3 CFR part 1989 Comp., p. 235), “Debarment and Suspension.” The SAM Exclusions contains the names of parties debarred, suspended, or otherwise excluded by agencies, as well as parties declared ineligible under statutory or regulatory authority other than Executive Order 12549.

**G. Byrd Anti-Lobbying Amendment (31U.S.C. 1352)**

Contractor agrees to file any required anti-lobbying certification required for agreements funded by Federal grants. Contractor agrees and certifies that it will not and has not used Federal appropriated funds to pay any person or organization for influencing or attempting to influence an officer or employee of any agency, a member of Congress, officer or employee of Congress, or an employee of a member of Congress in connection with obtaining any Federal contract, grant or any other award covered by 31 U.S.C. 1352. Contractor agrees to disclose any lobbying with non-Federal funds that takes place in connection with obtaining this Agreement or any Federal award. Such disclosures are forwarded from tier to tier up to the non-Federal award.

**H. Domestic Preferences for Procurement. (2 CFR Part 200.322)**

Contractor agrees to, as appropriate, to the extent consistent with law, and to the greatest extent practicable, provide a preference for the purchase, acquisition, or use of goods, products, or materials produced in the United States (including but not limited to iron, aluminum, steel, cement, and other manufactured products). The requirements of this section must be included in all subawards including all contracts and purchase orders for work or product under this award.

**I. Procurement of Recovered Materials (2 CFR Part 200.323)**

Contractor agrees to comply with section 6002 of the Solid Waste Disposal Act, as amended by the Resource Conservation and Recovery Act. The requirements of Section 6002 include procuring only items designated in guidelines of the Environmental Protection Agency (EPA) at 40 CFR Part 247 that contain the highest percentage of recovered materials practicable, consistent with maintaining a satisfactory level of competition, where the purchase price of the item exceeds \$10,000 or the value of the quantity acquired during the preceding fiscal year exceeded \$10,000; procuring solid waste management services in a manner that maximizes energy and resource recovery; and establishing an affirmative procurement program for procurement of recovered materials identified in the EPA guidelines.

**J. Prohibition on Certain Telecommunications and Video Surveillance Services or Equipment (2 CFR Part 200.216)**

Contractor is prohibited from obligating or expending loan or grant funds to:

1. Procure or obtain;
2. Extend or renew a contract to procure or obtain; or
3. Enter into a contract (or extend or renew a contract) to procure or obtain equipment, services, or systems that uses covered telecommunications equipment or services as a substantial or essential component of any system, or as critical technology as part of any system. As described in Public Law 115-232, section 889, covered telecommunications equipment is telecommunications equipment produced by Huawei Technologies Company or ZTE Corporation (or any subsidiary or affiliate of such entities).
  - i. For the purpose of public safety, security of government facilities, physical security surveillance of critical infrastructure, and other national security purposes, video surveillance and telecommunications equipment produced by Hytera Communications Corporation, Hangzhou Hikvision Digital Technology Company, or Dahua Technology Company (or any subsidiary or affiliate of such entities).
  - ii. Telecommunications or video surveillance services provided by such entities or using such equipment.
  - iii. Telecommunications or video surveillance equipment or services produced or provided by an entity that the Secretary of Defense, in consultation with the Director of the National Intelligence or the Director of the Federal Bureau of Investigation, reasonably believes to be an entity owned or controlled by, or otherwise connected to, the government of a covered foreign country.



**ACKNOWLEDGEMENT OF MANATEE COUNTY SPECIAL PROVISIONS –  
FEDERAL GRANTS – TERMS AND CONDITIONS  
SOLICITATION NO. 26-R089352DJ  
ATTACHMENT**

**Acknowledge all Special Provisions –Federal Grants Terms and Conditions have been received and Proposer / Bidder shall abide by all applicable federal provisions as defined in 2 CFR Part 200.327 – Appendix II to Part 200 Contract Provisions for Non-Federal Entity Contracts Under Federal Awards.**

\_\_\_\_\_  
**Signature/Authorized Certifying Official**

\_\_\_\_\_  
**Printed Name and Title**

\_\_\_\_\_  
**Organization**

\_\_\_\_\_  
**Date**

**FEDERAL FUNDING COMPLIANCE ADDENDUM**

Applicable to All Federally Funded Projects

1. Federal Compliance

Contractor agrees to comply with all applicable federal statutes, regulations, executive orders, and the terms and conditions of any applicable federal award, including but not limited to 2 CFR Part 200 (Uniform Administrative Requirements, Cost Principles, and Audit Requirements for Federal Awards).

2. No Cost Plus Percentage of Cost

Pursuant to 2 CFR §200.323(d), the Contractor is prohibited from using a cost-plus-a-percentage-of-cost or percentage of construction cost method of contracting.

3. Termination for Cause and Convenience

The County may terminate federally funded work, in whole or in part, for cause or convenience when such termination is in the best interest of the County or the federal awarding agency, in accordance with 2 CFR §200.340.

4. Equal Employment Opportunity

For construction contracts exceeding \$10,000, Contractor shall comply with Executive Order 11246, as amended, and the implementing regulations at 41 CFR Part 60.

5. Davis-Bacon Act

When required by the federal award, Contractor shall comply with the Davis-Bacon Act (40 U.S.C. §3141 et seq.), including payment of prevailing wages and submission of certified payrolls.

6. Byrd Anti-Lobbying Amendment

Contractor certifies compliance with 31 U.S.C. §1352 and agrees that no federally appropriated funds have been or will be used to influence any federal officer or employee in connection with the awarding of any federal contract, grant, or loan.

## 7. Clean Air Act and Federal Water Pollution Control Act

For contracts exceeding \$150,000, Contractor shall comply with all applicable standards, orders, or regulations issued pursuant to the Clean Air Act (42 U.S.C. §7401 et seq.) and the Federal Water Pollution Control Act (33 U.S.C. §1251 et seq.).

## 8. Debarment and Suspension

Contractor certifies that it is not debarred, suspended, or otherwise excluded from participation in federal assistance programs and shall maintain an active registration in SAM.gov throughout the performance of federally funded work, in accordance with 2 CFR §200.213.

## 9. Access to Records and Audits

Contractor agrees to provide the County, the federal awarding agency, Inspectors General, the Comptroller General of the United States, and any pass-through entity access to records as required by 2 CFR §§200.337–200.338. Records shall be retained for no less than five (5) years after final payment, or longer if required by the federal award.

## 10. Remedies for Noncompliance

In accordance with 2 CFR §200.339, the County may impose remedies for noncompliance, including withholding of payments, suspension, termination, or disallowance of costs.

## 11. Allowable Costs

Only costs allowable under Subpart E of 2 CFR Part 200 and the applicable federal award are eligible for reimbursement with federal funds.

## 12. Conflict of Interest

Contractor shall comply with 2 CFR §200.318(c) and certify that no conflicts of interest exist that would impair the integrity of federally funded procurements.

## 13. Applicability and Activation

This Addendum is automatically applicable to any task order, work authorization, or project under the Agreement that the County identifies as federally funded. No additional amendment is required for activation.

#### 14. Copeland “Anti-Kickback” Act

Compliance with the Copeland “Anti-Kickback” Act.

Contractor. The Contractor shall comply with 18 U.S.C. § 874, 40 U.S.C. § 3145, and the requirements of 29 C.F.R. Part 3 as may be applicable, which are incorporated by reference into this contract.

Subcontracts. The Contractor or Subcontractor shall insert in any subcontracts the clause above and such other clauses as FEMA may by appropriate instructions require, and a clause requiring the subcontractors to include these clauses in any lower-tier subcontracts. The Prime Contractor shall be responsible for the compliance by any subcontractor or lower-tier subcontractor with all these contract clauses.

Breach. A breach of the contract clauses above may be grounds for termination of the contract, and for debarment as a contractor and subcontractor as provided in 29 C.F.R. § 5.12.



**AGREEMENT No. [number]**

**[TITLE]**

**between**

**MANATEE COUNTY  
(COUNTY)**

**and**

**[CONTRACTOR NAME]  
(CONTRACTOR)**

## AGREEMENT FOR [TITLE]

**THIS AGREEMENT** is made and entered into as of this [date] day of [month], 2024 (“Effective Date”), by and between **MANATEE COUNTY**, a political subdivision of the State of Florida, (“**COUNTY**”), with offices located at 1112 Manatee Avenue West, Bradenton, Florida 34205, and [**COMPANY NAME**], a [<enter the state of incorporation/organization and identify if it is a corporation/company/limited liability corporation, etc.], (“**CONTRACTOR**”) with offices located at [address], and duly authorized to conduct business in the State of Florida. **COUNTY** and **CONTRACTOR** are collectively referred to as the “Parties” and individually as “Party.”

**WHEREAS**, **CONTRACTOR** engages in the business of [title]; and

**WHEREAS**, **COUNTY** has determined that it is necessary, expedient and in the best interest of **COUNTY** to retain **CONTRACTOR** to render the non-professional services described in this Agreement; and

**WHEREAS**, [this Agreement is a result of **CONTRACTOR'S** submission of a proposal/bid in response to Request for Proposal/Invitation for Bid No. number and **COUNTY** thereafter conducted a competitive selection process OR this Agreement is a sole source/single source contract] in accordance with the Manatee County Procurement Code.

**NOW, THEREFORE**, the **COUNTY** and **CONTRACTOR**, in consideration of the mutual covenants, promises, and representations contained herein, the sufficiency of which is hereby acknowledged, the Parties hereto agree as follows:

### **ARTICLE 1. SCOPE OF SERVICES**

**CONTRACTOR** shall provide non-professional services as described in **Exhibit A**, Scope of Services (“Services”). “Task” as used in this Agreement, refers to particular categories/groupings of Services specified in **Exhibit A**.

### **ARTICLE 2. EXHIBITS INCORPORATED**

This Agreement consists of a primary contract and [number] exhibits, which are as follows:

- Exhibit A** Scope of Services
- Exhibit B** Fee Rate Schedule
- Exhibit C** Affidavit of No Conflict
- Exhibit D** Anti-Human Trafficking Affidavit
- Exhibit E** Insurance and Bond Requirements

These Exhibits are attached hereto and are incorporated into this Agreement. In the event of a conflict between the terms and conditions provided in the Articles of this Agreement and any Exhibit, the provisions contained within these Articles shall prevail unless the Exhibit specifically states that it shall prevail.

### **ARTICLE 3. AGREEMENT TERM**

- A. This Agreement shall commence on the Effective Date and remain in force for an initial term of [number of years], unless terminated by COUNTY pursuant to Article 9.
- B. COUNTY reserves the right to extend the initial term of [number years] for an additional [number], [number]-year periods.

### **ARTICLE 4. COMPENSATION**

- A. CONTRACTOR shall be compensated for the Services and all expenditures incurred in providing the Services.
- B. The fee rates specified in **Exhibit B** shall be the total compensation for the Services and shall contain all applicable costs, to include salaries, office operation, transportation, equipment, overhead, general and administrative, incidental expenses, fringe benefits and operating margin.

### **ARTICLE 5. INVOICES AND TIME OF PAYMENT**

- A. Subject to the provisions of this Agreement, COUNTY shall pay CONTRACTOR for the Services at a rate of compensation according to the deliverable payment schedule stated in **Exhibit B**.
- B. COUNTY shall approve of all invoices prior to payment.
- C. COUNTY shall have forty-five (45) days from the receipt of an invoice seeking payment of fees or costs to either pay the invoice, or notify CONTRACTOR that the deliverable, or any part thereof, is unacceptable.
- D. COUNTY shall have the right to retain from any payment due CONTRACTOR under this Agreement, an amount sufficient to satisfy any amount of liquidated damages due and owing to COUNTY by CONTRACTOR on any other Agreement between CONTRACTOR and COUNTY.
- E. All costs of providing the Services shall be the responsibility of CONTRACTOR.
- F. Any dispute between COUNTY and CONTRACTOR with regard to the Services or CONTRACTOR'S invoice shall be resolved pursuant to the dispute resolution procedures established by Manatee County Procurement Code and Article 12 of this Agreement.

### **ARTICLE 6. RESPONSIBILITIES OF CONTRACTOR**

- A. CONTRACTOR shall appoint an Agent with respect to the Services to be performed by CONTRACTOR pursuant to this Agreement. CONTRACTOR'S Agent shall have the authority to make representations on behalf of CONTRACTOR, receive information, and interpret and define the needs of CONTRACTOR and make decisions pertinent to the Services. CONTRACTOR'S Agent shall have the right to designate other employees of CONTRACTOR to serve in his or her absence. CONTRACTOR reserves the right to

designate a different agent, provided that COUNTY is given advance written notice thereof.

- B. CONTRACTOR shall perform the Services in accordance with the terms and conditions of this Agreement.
- C. CONTRACTOR shall ensure that all employees assigned to render the Services are duly qualified, registered, licensed or certified to provide the Services required.
- D. CONTRACTOR shall be responsible for collecting all existing data required for the successful completion of each Task.
- E. CONTRACTOR shall not engage in any obligations, undertakings, contracts or professional obligations that create a conflict of interest, or even an appearance of a conflict of interest, with respect to the Services. CONTRACTOR attests to this via an Affidavit of No Conflict, **Exhibit C**.
- F. CONTRACTOR shall be entitled to rely upon information provided from COUNTY. Information may include, but is not limited to, additional services, consultations, investigations, and reports necessary for the execution of CONTRACTOR'S work under this Agreement. CONTRACTOR shall be fully responsible for verifying, to the extent practicable, documents and information provided by COUNTY and identifying any obvious deficiencies concerning the documents and information provided. CONTRACTOR shall notify COUNTY of any errors or deficiencies noted in such information provided and assist, to the extent practicable, COUNTY in the identification and resolution of same. CONTRACTOR agrees to incorporate the provisions of this paragraph in any subcontract into which it might enter with reference to the work performed under this Agreement.
- G. CONTRACTOR shall be responsible for the professional quality and technical accuracy of the Services and any other services furnished by CONTRACTOR under this Agreement. CONTRACTOR shall, without additional compensation, correct or revise any errors or deficiencies in the Services.
- H. CONTRACTOR shall maintain an adequate and competent staff of professionally qualified persons during the term of this Agreement for the purpose of rendering the required Services hereunder. CONTRACTOR shall not sublet, assign or transfer any Services without prior written consent of COUNTY.
- I. COUNTY may require in writing that CONTRACTOR remove from the Services any of CONTRACTOR'S personnel that COUNTY determines to be incompetent, careless or otherwise objectionable. No claims for an increase in compensation or agreement term based on COUNTY'S use of this provision will be valid.
- J. CONTRACTOR understands and agrees that this is a firm fixed price contract and that there shall be no allowances or reimbursement for any cost whatsoever except as otherwise explicitly provided in this Agreement. CONTRACTOR agrees to fulfill its obligations under this Agreement, regardless of cost, for the sole and sufficient compensation



stated in Exhibit B with no expectation of additional compensation. COUNTY will not be obligated to pay CONTRACTOR any amount in excess of the firm fixed price specified in Exhibit B.

#### **ARTICLE 7. RESPONSIBILITIES OF COUNTY**

- A. COUNTY shall, through its County Administrator, appoint an individual to serve as County Representative. The County Representative shall have the authority to transmit instructions, receive information, interpret and define the policy of COUNTY and make decisions pertinent to the Services. COUNTY reserves the right to designate a different County Representative, provided that CONTRACTOR is given advance written notice thereof.
- B. COUNTY shall make available, at no cost to CONTRACTOR, information relative to the project that is useful in the performance of the Services.
- C. COUNTY shall provide prompt notice to CONTRACTOR whenever COUNTY observes or otherwise becomes aware of any defect in the performance of the Services.
- D. COUNTY shall give careful and reasonable consideration to the findings and recommendations of CONTRACTOR and shall respond and issue notices to proceed in a timely manner.
- E. COUNTY personnel shall be available on a time-permitting basis, where required and necessary to assist CONTRACTOR. The availability and necessity of said personnel to assist CONTRACTOR shall be at the discretion of COUNTY.
- F. COUNTY shall perform the responsibilities enumerated in this Article at no cost to CONTRACTOR.

#### **ARTICLE 8. COUNTY OWNERSHIP OF WORK PRODUCT**

The Parties agree that COUNTY shall have exclusive ownership of all reports, documents, designs, ideas, materials, reports, concepts, plans, creative works, and other work product developed for or provided to COUNTY in connection with this Agreement, and all patent rights, copyrights, trade secret rights and other intellectual property rights relating thereto (collectively “the Intellectual Property”). CONTRACTOR hereby assigns and transfers all rights in the Intellectual Property to COUNTY. CONTRACTOR further agrees to execute and deliver such assignments and other documents as COUNTY may later require to perfect, maintain and enforce COUNTY’S rights as sole owner of the Intellectual property, including all rights under patent and copyright law.

#### **ARTICLE 9. TERMINATION OF AGREEMENT**

##### **A. TERMINATION FOR CAUSE:**

- 1. COUNTY shall have the right, by written notice to CONTRACTOR, to terminate this Agreement, in whole or in part, for failure to substantially comply with the terms and conditions of this Agreement, to include:

- a. Failure to provide Services that comply with the specifications herein or that fail to meet COUNTY'S performance standards;
  - b. Failure to perform the Services within the time specified in this Agreement; or
  - c. Work that is at a rate that disrupts the overall performance of this Agreement.
2. Prior to termination for default, COUNTY shall provide adequate written notice to CONTRACTOR, affording CONTRACTOR the opportunity to cure the deficiencies or to submit a specific plan to resolve the deficiencies within ten (10) days (or the period specified in the notice) after receipt of the notice. Failure to adequately cure the deficiency shall result in termination action.
  3. Such termination may also result in suspension or debarment of CONTRACTOR in accordance with Manatee County's Procurement Ordinance, Chapter 2-26. CONTRACTOR shall be liable for any damage to COUNTY resulting from CONTRACTOR'S default of the Agreement.
  4. In the event of termination of this Agreement, CONTRACTOR shall be liable for any damage to COUNTY resulting from CONTRACTOR'S default of this Agreement. This liability includes any increased costs incurred by COUNTY in completing performance under this Agreement.
  5. In the event of termination by COUNTY for any cause, CONTRACTOR shall not have any right or claim against COUNTY for lost profits or compensation for lost opportunities. After a receipt of COUNTY'S Notice of Termination and except as otherwise directed by COUNTY, CONTRACTOR shall:
    - a. Stop the Services on the date and to the extent specified;
    - b. Terminate and settle all orders and subcontracts relating to the performance of the terminated Services;
    - c. Transfer all work in process, completed work, and other materials related to the terminated Services as directed by COUNTY; and
    - d. Continue and complete all parts of the Services that have not been terminated.

#### B. TERMINATION WITHOUT CAUSE:

COUNTY may terminate this Agreement, in whole or in part, without cause. COUNTY shall provide CONTRACTOR a written "Notice of Intent to Terminate" thirty (30) days prior to the date of termination. If this Agreement is terminated by the COUNTY without cause, CONTRACTOR shall be entitled to payment for all Services performed to the satisfaction of the COUNTY and all expenses incurred under this Agreement prior to termination, less any costs, expenses or damages due to the failure of the CONTRACTOR to properly perform pursuant to this Agreement. CONTRACTOR shall not be entitled to any other compensation, including anticipated profits on unperformed Services.

## **ARTICLE 10. TRANSITION SERVICES UPON TERMINATION**

Upon termination or expiration of this Agreement, CONTRACTOR shall cooperate with COUNTY to assist with the orderly transfer of the Services provided by CONTRACTOR to COUNTY. Prior to termination or expiration of this Agreement, COUNTY may require CONTRACTOR to perform and, if so required, CONTRACTOR shall perform, certain transition services necessary to shift the Services to another provider or to COUNTY itself as described below (the "Transition Services"). The Transition Services may include but shall not be limited to:

- A. Working with COUNTY to jointly develop a mutually agreed upon Transition Services plan to facilitate the termination of the Services;
- B. Executing the Transition Services plan activities;
- C. Answering questions regarding the Services on an as-needed basis; and
- D. Providing such other reasonable Services needed to effectuate an orderly transition to a new service provider or to COUNTY.

## **ARTICLE 11. DISPUTE RESOLUTION**

- A. Disputes shall be resolved in accordance with the Manatee County Purchasing Code (Chapter 2-26 of the Manatee County Code of Ordinances). Any dispute resolution constituting a material change in this Agreement shall not be final until an amendment to this Agreement has been approved and executed by the County Purchasing Official.
- B. CONTRACTOR agrees it must exhaust all dispute resolution procedures set forth in Manatee County's Procurement Code prior to instituting any action in state or federal court or before any administrative agency or tribunal.

## **ARTICLE 12. COMPLIANCE WITH LAWS**

All Services rendered or performed by CONTRACTOR pursuant to the provisions of this Agreement shall be in compliance with all applicable local, state and federal laws and ordinances. CONTRACTOR shall have and keep current at all times during the term of this Agreement all licenses and permits as required by law.

## **ARTICLE 13. NON-DISCRIMINATION**

CONTRACTOR shall not discriminate against any employee or applicant for employment because of race, color, sex, creed, national origin, disability or age, and will take affirmative action to ensure that all employees and applicants are afforded equal employment opportunities. Such action will be taken with reference to, but shall not be limited to, recruitment, employment, job assignment, promotion, upgrading, demotion, transfer, layoff or termination, rates of training or retraining (including apprenticeship and on-the-job training).

## **ARTICLE 14. MAINTENANCE OF RECORDS; AUDITS; LICENSES**

- A. CONTRACTOR shall maintain records, accounts, property records, and personnel records in

accordance with generally accepted accounting principles, as deemed necessary by COUNTY to assure proper accounting of funds and compliance with the provisions of this Agreement.

- B. CONTRACTOR shall provide COUNTY all information, reports, records and documents required by this Agreement or by COUNTY ordinances, rules or procedures, or as needed by COUNTY to monitor and evaluate CONTRACTOR'S performance. Such materials shall also be made available to COUNTY upon request for auditing purposes. Inspection or copying will occur during normal business hours, and as often as COUNTY may deem necessary. COUNTY shall have the right to obtain and inspect any audit pertaining to the performance of this Agreement or CONTRACTOR made by any local, state or federal agency. To the extent such materials are in the possession of a third party, CONTRACTOR must obtain them from that third party, or certify in writing to COUNTY why it was unable to do so. CONTRACTOR shall retain all records and supporting documents related to this Agreement in accordance with all applicable laws, rules and regulations, and, at a minimum, retain all records and supporting documents related to this Agreement, except duplicate copies or drafts, for at least three (3) years after the termination date.
- C. CONTRACTOR shall obtain any licenses required to provide the Services and maintain full compliance with any licensure requirements. Copies of reports provided to or by any licensing or regulatory agency shall be forwarded to COUNTY within ten (10) days of receipt by CONTRACTOR. CONTRACTOR shall immediately notify COUNTY if the required licenses of any of its principles or agents working on this Agreement are terminated, suspended, revoked or are otherwise invalid and/or are no longer in good standing.

#### **ARTICLE 15. PUBLIC RECORDS**

Pursuant to Florida Statutes §119.0701, to the extent CONTRACTOR is performing services on behalf of COUNTY, CONTRACTOR shall:

- A. Keep and maintain public records that would ordinarily be required by COUNTY to perform the service.
- B. Upon request from COUNTY'S custodian of public records, provide COUNTY with a copy of the requested records or allow the records to be inspected or copied within a reasonable time at a cost that does not exceed the cost provided in Chapter 119, Florida Statutes, or as otherwise provided by law.
- C. Ensure that public records that are exempt or confidential from public records disclosure requirements are not disclosed except as authorized by law for the duration of this Agreement and following completion of this Agreement if CONTRACTOR does not transfer the records to COUNTY.
- D. Upon completion of this Agreement, transfer, at no cost, to COUNTY all public records in possession of CONTRACTOR or keep and maintain public records required by COUNTY to perform the service. If CONTRACTOR transfers all public records to COUNTY upon completion of this Agreement, CONTRACTOR shall destroy any duplicate public records

that are exempt or confidential and exempt from public records disclosure requirements. If CONTRACTOR keeps and maintains public records upon completion of this Agreement, CONTRACTOR shall meet all applicable requirements for retaining public records. All records stored electronically must be provided to COUNTY, upon request from COUNTY'S custodian of public records, in a format that is compatible with the information technology systems of COUNTY.

**IF CONTRACTOR HAS QUESTIONS REGARDING THE APPLICATION OF CHAPTER 119, FLORIDA STATUTES, TO COUNTY'S DUTY TO PROVIDE PUBLIC RECORDS RELATING TO THIS AGREEMENT, CONTACT THE CUSTODIAN OF PUBLIC RECORDS AT:**

**Phone: 941.742.5845**

**Email: [lacy.pritchard@mymanatee.org](mailto:lacy.pritchard@mymanatee.org)**

**Mail or hand delivery:  
Attn: Records Manager  
1112 Manatee Avenue West  
Bradenton, FL 34205**

**ARTICLE 16. INDEMNIFICATION**

- A. Each Party shall defend, indemnify, save and hold harmless the other, its officers, employees and agents, from any and all third-party claims, liabilities, loss, or cause of action for property damage or bodily injury, including death, arising out of any negligent actions or omissions of the indemnifying Party, its agents, officers, employees or agents in the performance of this Agreement, including without limitation, defects in design, or errors or omissions that result in material cost increases to the indemnified Party. Such indemnification shall include, but not be limited to, the payment of all valid claims, losses, and judgements of any nature whatsoever in connection therewith and the payment of all related fees and costs, including attorneys' fees, incurred by the indemnified Party in connection with the indemnifying Party's activities arising out of the performance of this Agreement. This indemnification obligation shall not be construed to negate, abridge or reduce any other rights or remedies which otherwise may be available to an indemnified Party or person described in this paragraph or deemed to affect the rights, privileges and immunities of COUNTY as set forth in Section 768.28, Florida Statutes.
- B. CONTRACTOR will indemnify, defend, save and hold harmless the COUNTY, its officers, and employees all third-party claims, liabilities, loss, or cause of action that the Services constitutes an infringement of any third-party intellectual property right(s), unless such claim is based on COUNTY'S wrongful or illegitimate use of the Services. The foregoing states the entire liability of CONTRACTOR and the sole and exclusive remedy for COUNTY with respect to any third-party claim of infringement or misappropriation of intellectual property rights. Such indemnification shall include, but not be limited to, the payment of all valid

claims, losses, and judgments of any nature whatsoever in connection therewith and the payment of all related fees and costs, including attorneys' fees.

#### **ARTICLE 17. NO WAIVER OF SOVEREIGN IMMUNITY**

Nothing herein shall be interpreted as a waiver by COUNTY of its rights, including the limitations of the waiver of immunity as set forth in Section 768.28, Florida Statutes, or any other applicable statutes or immunities. COUNTY expressly reserves these rights to the full extent allowed by law.

#### **ARTICLE 18. INSURANCE**

- A. CONTRACTOR shall, at its own cost and expense, acquire and maintain (and cause any subcontractors, representatives, or agents to acquire and maintain) insurance policies that comply with the Insurance Requirements, attached as **Exhibit E**, during the term of this Agreement, to include any renewal terms.
- B. Certificates of Insurance and copies of policies evidencing the insurance coverage specified in **Exhibit E** shall be filed with the Purchasing Official before the Effective Date of this Agreement. The required certificates shall identify the type of policy, policy number, date of expiration, amount of coverage, companies affording coverage, shall refer specifically to the title of this Agreement, and shall name Manatee County as an additional insured. No changes shall be made to the insurance coverage without prior written approval by COUNTY'S Risk Management Division.
- C. Insurance shall remain in force for at least three (3) years after completion of the Services in the amounts and types of coverage as required by **Exhibit E**, including coverage for all Services completed under this Agreement.
- D. If the initial insurance expires prior to the termination of this Agreement, renewal Certificates of Insurance and required copies of policies shall be furnished by CONTRACTOR and delivered to the Purchasing Official thirty (30) days prior to the date of their expiration.

#### **ARTICLE 19. SOLICITATION OF AGREEMENT**

CONTRACTOR warrants that it has not employed or retained any company or person other than a bona fide employee working solely for CONTRACTOR to solicit or secure this Agreement, and that it has not paid or agreed to pay any company or person other than an employee working solely for CONTRACTOR, any fee, commission, percentage, brokerage fee, gift, contingent fee, or any other consideration contingent upon or resulting from the award or making of this Agreement. For breach or violation of this warranty, COUNTY shall have the right to annul this Agreement without liability, or at its discretion, to deduct from this Agreement price or consideration or otherwise recover the full amount of such fee, commission, percentage, brokerage fee, gifts, or contingent fee.

#### **ARTICLE 20. ASSIGNMENT AND SUBCONTRACTING**

CONTRACTOR shall not assign or transfer any right or duty under this Agreement to any other Party without the prior written consent of COUNTY. In the event CONTRACTOR asserts it is

necessary to utilize the services of third parties to perform any of the Services, CONTRACTOR shall first obtain prior written approval of COUNTY.

Approval to utilize any third party shall not relieve CONTRACTOR from any direct liability or responsibility to COUNTY pursuant to the provisions of this Agreement, or obligate COUNTY to make any payments other than payments due to CONTRACTOR as outlined in this Agreement. All terms and conditions of this Agreement shall extend to and be binding on any approved purchaser, assignee, or other successor in interest.

Assignment, pledging, sale, transfer or encumbering of any interest or rights under this Agreement, to anyone other than the CONTRACTOR, without the prior written consent of the COUNTY, shall be grounds for immediate termination of this Agreement.

**ARTICLE 21. CERTIFICATION OF NON-PAYMENT OF COMMISSION OR GIFT**

CONTRACTOR warrants that it has not employed or retained any company or person other than a bona fide employee working solely for CONTRACTOR to solicit or secure this Agreement, and that it has not paid or agreed to pay any company or person other than an employee working solely for CONTRACTOR, any fee, commission, percentage, brokerage fee, gift, contingent fee, or any other consideration contingent upon or resulting from the award or making of this Agreement. For breach or violation of this warranty, COUNTY shall have the right to annul this Agreement, without liability or at its discretion to deduct from the agreement price consideration or otherwise recover the full amount of such fee, commission, percentage, brokerage fee, gifts, or contingent fee.

**ARTICLE 22. KEY PERSONNEL**

The following key personnel shall be the COUNTY primary contacts assigned to this Agreement by CONTRACTOR:

[Enter Name, Title]

CONTRACTOR shall notify the COUNTY in writing within ten (10) business days of any changes to the key personnel.

**ARTICLE 23. SUB-CONTRACTORS**

If it is determined by either party that a sub-contractor will be required in order to complete the services as described in **Exhibit A**, CONTRACTOR shall request the use of a sub-contractor in writing and receive prior written approval from COUNTY.

**ARTICLE 24. LIABILITY FOR NEGLIGENCE.**

To the fullest extent allowed by law, the individuals performing the Services pursuant to this Agreement shall be personally liable for negligent acts or omissions. To the fullest extent allowed by law, CONTRACTOR shall likewise be liable for negligent acts or omissions in the performance of the Services.

## **ARTICLE 25. NOTICES**

All notices, requests and authorizations provided for herein shall be in writing and shall be delivered by hand or mailed through the U.S. Mail, addressed as follows:

To COUNTY:           Manatee County Government  
                          [Division/Department]  
                          Attn: [Title of Contact person]  
                          [Address]  
                          [City/State/Zip]  
                          Phone: (941) [number]  
                          Email: [email]

To CONTRACTOR:    [Company Name]  
                          Attn: [Title of Contact person]  
                          [Address]  
                          [City/State/Zip]  
                          Phone: ([area code) [number]  
                          Email: [email]

## **ARTICLE 26. RELATIONSHIP OF PARTIES**

The relationship of CONTRACTOR to COUNTY shall be that of an independent contractor. Nothing herein contained shall be construed as vesting or delegating to CONTRACTOR or any of the officers, employees, personnel, agents, or sub-contractors of CONTRACTOR any rights, interest or status as an employee of COUNTY. COUNTY shall not be liable to any person, firm or corporation that is employed by Agreements or provides goods or services to CONTRACTOR in connection with this Agreement or for debts or claims accruing to such parties. CONTRACTOR shall promptly pay, discharge or take such action as may be necessary and reasonable to settle such debts or claims.

## **ARTICLE 27. NO CONFLICT**

By accepting award of this Agreement, CONTRACTOR, which shall include its directors, officers and employees, represents that it presently has no interest in and shall acquire no interest in any business or activity which would conflict in any manner with the performance of duties or Services required hereunder.

## **ARTICLE 28. ETHICAL CONSIDERATIONS**

CONTRACTOR recognizes that in rendering the Services, CONTRACTOR is working for the residents of Manatee County, Florida, subject to public observation, scrutiny and inquiry; and based upon said recognition CONTRACTOR shall, in all of its relationships with COUNTY pursuant to this Agreement, conduct itself in accordance with all of the recognized applicable ethical standards set by any related national societies, and the reasonable traditions to perform the Services. CONTRACTOR shall be truthful in its communications with COUNTY personnel regarding matters pertaining to this Agreement and the Services rendered to COUNTY.



## **ARTICLE 29. PUBLIC ENTITY CRIMES**

CONTRACTOR has been made aware of the Florida Public Entity Crimes Act, Florida Statutes § 287.133, specifically section 2(a), and COUNTY'S requirement that CONTRACTOR comply with it in all respects prior to and during the term of this Agreement.

## **ARTICLE 30. TAXES**

COUNTY is exempt from Federal Excise and State Sales Taxes (F.E.T. Exemption Certificate No. 59-78-0089K; FL Sales Tax Exemption Certificate No. 51-02-027548-53C). Therefore, CONTRACTOR is prohibited from charging or imposing any sales or service taxes. Nothing herein shall affect CONTRACTOR'S normal tax liability.

CONTRACTOR shall be responsible for payment of federal, state, and local taxes which may be imposed upon CONTRACTOR under applicable law to the extent that CONTRACTOR is responsible for the payment of same under applicable law.

## **ARTICLE 31. FORCE MAJEURE**

Neither Party shall be considered in default in performance of its obligations hereunder to the extent that performance of such obligations or any of them is delayed or prevented by Force Majeure.

Force Majeure shall include, but not be limited to, hostility, revolution, civil commotion, strike, epidemic, accident, fire, flood, wind, earthquake, hurricane, explosion, lack of or failure of transportation facilities, any law, proclamation, regulation, ordinance or other act of government, or any act of God or any cause whether of the same or different nature, existing or future; provided that the cause, whether or not enumerated in this Article, is beyond the control and without the fault or negligence of the Party seeking relief under this Article.

## **ARTICLE 32. GOVERNING LAW, JURISDICTION AND VENUE**

This Agreement shall be governed by the laws of the State of Florida. Any action filed regarding this Agreement will be filed only in Manatee County, Florida, or if in Federal Court, the Middle District of Florida, Tampa Division.

## **ARTICLE 33. ATTORNEY FEES**

In the event of any litigation arising under the terms of this Agreement, each Party shall be responsible for their own attorney's fees, including appellate fees, regardless of the outcome of the litigation.

## **ARTICLE 34. PATENT AND COPYRIGHT RESPONSIBILITY**

Any material or design specified by CONTRACTOR or supplied by CONTRACTOR pursuant to this Agreement shall not knowingly infringe any patent or copyright, and CONTRACTOR shall be solely responsible for securing any necessary licenses required for patented or copyrighted material utilized by CONTRACTOR in the performance of the Services.

## **ARTICLE 35. AMENDMENTS**

This Agreement and Exhibits referenced herein constitute the entire Agreement between the Parties with respect to subject matter and mutually agree that no verbal agreements, representations, warranties or other understandings affecting the same exist. No amendment hereof shall be effective until and unless reduced to writing and executed by the Parties. The Parties shall execute any additional documents as may be necessary to implement and carry out the intent of this Agreement.

## **ARTICLE 36. SEVERABILITY**

It is understood and agreed by the Parties hereto that if any part, term, or provision of this Agreement is held to be illegal or in conflict with any law, the validity of the remaining portions or provisions shall not be affected, and the rights and obligations of the Parties shall be construed and enforced as if this Agreement did not contain the particular part, term or provision held to be invalid.

## **ARTICLE 37. LEGAL REFERENCES**

All references to statutory sections or chapters shall be construed to include subsequent amendments to such provisions, and to refer to the successor provision of any such provision. References to “applicable law” and “general law” shall be construed to include provisions of local, state and federal law, whether established by legislative action, administrative rule or regulation, or judicial decision.

## **ARTICLE 38. HEADINGS, CONSTRUCTION**

The Parties agree that they have each participated in the drafting of this Agreement and that the rules with respect to construing ambiguities against the drafter of a contract shall not apply in any action or litigation regarding this Agreement. All articles and descriptive headings of paragraphs of this Agreement are inserted for convenience only and shall not affect the construction or interpretation hereof.

## **ARTICLE 39. TIME**

For purposes of computing any period of number of days hereunder for notices or performance of ten (10) days or less, Saturdays, Sundays and holidays shall be excluded, unless otherwise stated.

## **ARTICLE 40. E-VERIFY**

The CONTRACTOR, and any subcontractor thereof, shall register with and use the E-Verify system to verify the work authorization status of all new employees of the CONTRACTOR or subcontractor. The CONTRACTOR hereby represents and warrants that it has, and shall remain throughout the duration of this Agreement, registered with, and uses and shall continue to use, the E-Verify system. The CONTRACTOR shall not enter into any contract with a subcontractor for services hereunder unless such subcontractor also has registered with and uses the E-Verify system. If the CONTRACTOR enters into a contract with a subcontractor, the subcontractor shall provide the CONTRACTOR with an affidavit stating that the subcontractor does not

employ, contract with, or subcontract with an unauthorized alien. The CONTRACTOR shall maintain a copy of such affidavit for the duration of this Agreement.

Pursuant to Section 488.095(5)(c)3, Florida Statutes, the COUNTY is authorized to terminate this Agreement if it has a good faith belief that the CONTRACTOR has knowingly violated Section 448.09(1), Florida Statutes, regarding the employment of someone not authorized to work by the immigration laws of the United States, the U.S. Attorney General, or the Secretary of the Department of Homeland Security. Such termination action is not considered a breach of contract.

#### **ARTICLE 41. FUNDS FOR IDENTIFICATION DOCUMENTS**

No funds provided by the COUNTY pursuant to this Agreement shall be used for the purpose of issuing an identification card or document to an individual who does not provide proof of lawful presence in the United States.

#### **ARTICLE 42. ANTI-HUMAN TRAFFICKING**

CONTRACTOR shall provide County with a sworn affidavit signed by an officer or a representative of CONTRACTOR under penalty of perjury attesting that CONTRACTOR does not use coercion for labor or services, as such terms are defined in Section 787.06, Florida Statutes.

#### **ARTICLE 43. AUTHORITY TO EXECUTE**

Each of the Parties hereto covenants to the other Party that it has lawful authority to enter into this Agreement.

[Remainder of page intentionally left blank]

**IN WITNESS WHEREOF**, the Parties hereto have caused this Agreement to be duly executed effective as of the date set forth above.

**CONTRACTOR NAME**

By: \_\_\_\_\_

Printed Name: \_\_\_\_\_

Title: \_\_\_\_\_

Date: \_\_\_\_\_

**MANATEE COUNTY, a political subdivision  
of the State of Florida**

\_\_\_\_\_  
Jacob Erickson, MBA, CPPO, NIGP-CPP  
Purchasing Official

Date: \_\_\_\_\_

SAMPLE

**EXHIBIT A, SCOPE OF SERVICES**

SAMPLE

## **EXHIBIT B, FEE RATE SCHEDULE**

### **1. FEES**

Fees for the goods and services detailed in this Agreement shall be as indicated in this **Exhibit B**.

### **2. ESCALATION/DE-ESCALATION**

<Contractor/Supplier> fees for <type of good/service> shall remain firm for a minimum of <years/months> after execution of the Agreement. Any escalation or de-escalation in pricing thereafter will be based on the <identify the index source, index name, and the index number> change in most recent 12- month period. No more than price increase is allowed in a month period.

[Remainder of page intentionally left blank]

SAMPLE

**EXHIBIT C, AFFIDAVIT OF NO CONFLICT**

STATE OF \_\_\_\_\_  
COUNTY OF \_\_\_\_\_

BEFORE ME, the undersigned authority, this day personally appeared [INSERT NAME] \_\_\_\_\_  
\_\_\_\_\_, as [INSERT TITLE] \_\_\_\_\_ of  
[INSERT CONTRACTOR NAME] \_\_\_\_\_, (hereinafter  
"CONTRACTOR") with full authority to bind CONTRACTOR, who being first duly sworn,  
deposes and says that CONTRACTOR:

- (a) Is not currently engaged and will not become engaged in any obligations, undertakings or contracts that will require CONTRACTOR to maintain an adversarial role against the County or that will impair or influence the advice, recommendations or quality of work provided to the County; and
- (b) Has provided full disclosure of all potentially conflicting contractual relationships and full disclosure of contractual relationships deemed to raise a question of conflict(s); and
- (c) Has provided full disclosure of prior work history and qualifications that may be deemed to raise a possible question of conflict(s).

Affiant makes this Affidavit for the purpose of inducing Manatee County, a political subdivision of the State of Florida, to enter into this Agreement No. \_\_\_\_\_ for \_\_\_\_\_

DATED this \_\_\_\_\_ day of \_\_\_\_\_, 20\_\_\_\_\_.

\_\_\_\_\_  
CONTRACTOR Signature

The foregoing instrument was sworn to and acknowledged before me this \_\_\_\_\_ day of \_\_\_\_\_, 20\_\_\_\_\_, by [NAME] \_\_\_\_\_, as [TITLE] \_\_\_\_\_ of [CONTRACTOR] \_\_\_\_\_. He / She is personally known to me or has produced \_\_\_\_\_ [TYPE OF IDENTIFICATION] as identification.

\_\_\_\_\_  
Notary Signature  
Commission No. \_\_\_\_\_

***Please return this completed and signed exhibit with your agreement.***

**EXHIBIT D, ANTI-HUMAN TRAFFICKING AFFIDAVIT**

(Section 787.06, Florida Statutes)

Before me, the undersigned authority, personally appeared \_\_\_\_\_, who was sworn and says that the following information is true and correct:

1. My name is \_\_\_\_\_ of \_\_\_\_\_. I have been authorized by the Company to provide and execute this affidavit.
2. I am over eighteen years of age and the following information is given from my own personal knowledge.
3. Company is a nongovernmental entity and I hereby attest that Company does not use coercion for labor or services as defined in Section 787.06, Florida Statutes.
4. This affidavit is made and given by affiant under penalty of perjury with full knowledge of applicable Florida laws regarding sworn affidavits and the penalties and liabilities resulting from false statements and misrepresentations therein.

\_\_\_\_\_  
Signature

STATE OF \_\_\_\_\_  
COUNTY OF \_\_\_\_\_

Sworn to (or affirmed) and subscribed before me by means of  physical presence or  online notarization

this \_\_\_\_\_ day of \_\_\_\_\_, 2025, by \_\_\_\_\_, who

- is personally known to me or
- has produced \_\_\_\_\_ as identification.

[CHECK APPLICABLE BOXES TO SATISFY IDENTIFICATION REQUIREMENT OF SECTION 117.05, FLORIDA STATUTES]

\_\_\_\_\_ My Commission Expires: \_\_\_\_\_

Signature of Notary Public

(Legibly print, type, or stamp commissioned name of Notary Public and affix official notary seal below.)

***Please return this completed and signed exhibit with your agreement***



## **EXHIBIT E, INSURANCE AND BOND REQUIREMENTS**

The CONTRACTOR will not commence work under the resulting Agreement until all insurance coverages indicated by an “X” herein have been obtained. The CONTRACTOR shall obtain and submit to the Procurement Division within ten (10) calendar days from the date of notice of intent to award, at its expense, the following minimum amounts of insurance (inclusive of any amounts provided by an umbrella or excess policy): Work under this Agreement cannot commence until all insurance coverages indicated herein have been obtained on a standard ACORD form (inclusive of any amounts provided by an umbrella or excess policy):

### ***Automobile Liability Insurance Required Limits***

Coverage must be afforded under a per occurrence policy form including coverage for all owned, hired and non-owned vehicles for bodily injury and property damage of not less than:

- \$1,000,000 Combined Single Limit; OR
- \$ 500,000 Bodily Injury and \$500,000 Property Damage
- \$10,000 Personal Injury Protection (No Fault)
- \$500,000 Hired, Non-Owned Liability
- \$10,000 Medical Payments

*This policy shall contain severability of interests’ provisions.*

### ***Commercial General Liability Insurance Required Limits (per Occurrence form only; claims-made form is not acceptable)***

Coverage shall be afforded under a per occurrence policy form, policy shall be endorsed and name ‘Manatee County, a political subdivision of the State of Florida’ as an Additional Insured, and include limits not less than:

- \$1,000,000 Single Limit Per Occurrence
- \$2,000,000 Aggregate
- \$1,000,000 Products/Completed Operations Aggregate
- \$1,000,000 Personal and Advertising Injury Liability
- \$50,000 Fire Damage Liability
- \$10,000 Medical Expense, and
- \$1,000,000, Third Party Property Damage
- \$       Project Specific Aggregate (Required on projects valued at over \$10,000,000)

*This policy shall contain severability of interests’ provisions.*

### ***Employer’s Liability Insurance***

Coverage limits of not less than:

- \$100,000 Each Accident
- \$500,000 Disease Each Employee
- \$100,000 Disease Policy Limit

**Worker's Compensation Insurance**

**US Longshoremen & Harbor Workers Act**

**Jones Act Coverage**

Coverage limits of not less than:

- Statutory workers' compensation coverage shall apply for all employees in compliance with the laws and statutes of the State of Florida and the federal government.
- If any operations are to be undertaken on or about navigable waters, coverage must be included for the US Longshoremen & Harbor Workers Act and Jones Act.

Should 'leased employees' be retained for any part of the project or service, the employee leasing agency shall provide evidence of Workers' Compensation coverage and Employer's Liability coverage for all personnel on the worksite and in compliance with the above Workers' Compensation requirements. NOTE: Workers' Compensation coverage is a firm requirement. Elective exemptions are considered on a case-by-case basis and are approved in a very limited number of instances.

**Aircraft Liability Insurance Required Limits**

Coverage shall be afforded under a per occurrence policy form, policy shall be endorsed and name 'Manatee County a political subdivision of the State of Florida' as an Additional Insured, and include limits not less than:

- \$ Each Occurrence Property and Bodily Injury with no less than \$100,000 per passenger each occurrence or a 'smooth' limit.
- \$ General Aggregate.

**Un-Manned Aircraft Liability Insurance (Drone)**

Coverage shall be afforded under a per occurrence policy form, policy shall be endorsed and name 'Manatee County a political subdivision of the State of Florida' as an Additional Insured, and include limits not less than:

- \$ Each Occurrence Property and Bodily Injury; Coverage shall specifically include operation of Unmanned Aircraft Systems (UAS), including liability and property damage.
- \$ General Aggregate

**Installation Floater Insurance**

When the contract or agreement **does not** include construction of, or additions to, above ground building or structures, but does involve the installation of machinery or equipment, Installation Floater Insurance shall be afforded under a per occurrence policy form, policy shall be endorsed and name "Manatee County, a political subdivision of the State of Florida" as an Additional Insured, and include limits not less than:

- 100% of the completed value of such addition(s), building(s), or structure(s)

**Professional Liability and/or Errors and Omissions (E&O) Liability Insurances**  
Coverage shall be afforded under either an occurrence policy form or a claims-made policy form. If the coverage form is on a claims-made basis, then coverage must be maintained for a minimum of three years from termination of date of the contract. Limits must not be less than:

- \$ 1,000,000 Bodily Injury and Property Damage Each Occurrence
- \$ 2,000,000 General Aggregate

**Builder's Risk Insurance**

When the contract or agreement includes the construction of roadways and/or the addition of a permanent structure or building, including the installation of machinery and/or equipment, Builder's Risk Insurance shall be afforded under a per occurrence policy form, policy shall be endorsed and name "Manatee County, a political subdivision of the State of Florida" as an Additional Insured, and include limits not less than:

- An amount equal to 100% of the completed value of the project, or the value of the equipment to be installed
- The policy shall not carry a self-insured retention/deductible greater than \$10,000

Coverage shall be for all risks and include, but not be limited to, storage and transport of materials, equipment, supplies of any kind whatsoever to be used on or incidental to the project, theft coverage, and Waiver of Occupancy Clause Endorsement, where applicable.

**Cyber Liability Insurance**

Coverage shall comply with Florida Statute 501.171, shall be afforded under a per occurrence policy form, policy shall be endorsed and name 'Manatee County, a political subdivision of the State of Florida' as an Additional Insured, and include limits not less than:

- \$ Security Breach Liability
- \$ Security Breach Expense Each Occurrence
- \$ Security Breach Expense Aggregate
- \$ Replacement or Restoration of Electronic Data
- \$ Extortion Threats
- \$ Business Income and Extra Expense
- \$ Public Relations Expense

NOTE: Policy must not carry a self-insured retention/deductible greater than \$25,000.

**Hazardous Materials Insurance (As Noted Below)**

Hazardous materials include all materials and substances that are currently designated or defined as hazardous by the law or rules of regulation by the State of Florida or federal government.

All coverage shall be afforded under either an occurrence policy form or a claims-made policy form, and the policy shall be endorsed and name 'Manatee County, a political subdivision of the State of Florida' as an Additional Insured. If the coverage form is on a claims-made basis, then

coverage must be maintained for a minimum of three years from termination of date of the contract. Limits must not be less than:

**Pollution Liability**

Amount equal to the value of the contract, subject to a \$1,000,000 minimum, for Bodily Injury and Property Damage to include sudden and gradual release, each claim and aggregate.

**Asbestos Liability (If handling within scope of Contract)**

Amount equal to the value of the contract, subject to a \$1,000,000 minimum, for Bodily Injury and Property Damage to include sudden and gradual release, each claim and aggregate.

**Disposal**

When applicable, CONTRACTOR shall designate the disposal site and furnish a Certificate of Insurance from the disposal facility for Environmental Impairment Liability Insurance covering liability.

- Amount equal to the value of the contract, subject to a \$1,000,000 minimum, for Liability for Sudden and Accidental Occurrences, each claim and an aggregate.
- Amount equal to the value of the contract, subject to a \$1,000,000 minimum, for Liability for Non-Sudden and Accidental Occurrences, each claim and an aggregate.

**Hazardous Waste Transportation Insurance**

CONTRACTOR shall designate the hauler and have the hauler furnish a Certificate of Insurance for Automobile Liability insurance with Endorsement MCS-90 for liability arising out of the transportation of hazardous materials. EPA identification number shall be provided.

All coverage shall be afforded under either an occurrence policy form or a claims-made policy form and the policy shall be endorsed and name "Manatee County, a political subdivision of the State of Florida" as an Additional Insured. If the coverage form is on a claims-made basis, then coverage must be maintained for a minimum of three years from termination of date of the contract. Limits must not be less than:

- Amount equal to the value of the contract, subject to a \$1,000,000 minimum, per accident.

**Liquor Liability Insurance**

Coverage shall be afforded under a per occurrence policy form, policy shall be endorsed and name "Manatee County, a political subdivision of the State of Florida" as an Additional Insured, and include limits not less than:

- \$1,000,000 Each Occurrence and Aggregate

**Garage Keeper's Liability Insurance**

Coverage shall be required if the maintenance, servicing, cleaning or repairing of any County motor vehicles is inherent or implied within the provision of the contract.

Coverage shall be afforded under a per occurrence policy form, policy shall be endorsed and name "Manatee County, a political subdivision of the State of Florida" as an Additional Insured, and include limits not less than:

- Property and asset coverage in the full replacement value of the lot or garage.

**Bailee's Customer Liability Insurance**

Coverage shall be required for damage and/or destruction when County property is temporarily under the care or custody of a person or organization, including property that is on, or in transit to and from the person or organization's premises. Perils covered should include fire, lightning, theft, burglary, robbery, explosion, collision, flood, earthquake and damage or destruction during transportation by a carrier.

Coverage shall be afforded under a per occurrence policy form, policy shall be endorsed and name "Manatee County, a political subdivision of the State of Florida" as an Additional Insured, and include limits not less than:

- Property and asset coverage in the full replacement value of the County asset(s) in the CONTRACTOR'S care, custody and control.

**Hull and Watercraft Liability Insurance**

Coverage shall be afforded under a per occurrence policy form, policy shall be endorsed and name "Manatee County, a political subdivision of the State of Florida" as an Additional Insured, and include limits not less than:

- \$ Each Occurrence
- \$ General Aggregate
- \$ Fire Damage Liability
- \$10,000 Medical Expense, and
- \$ Third Party Property Damage
- \$ Project Specific Aggregate (Required on projects valued at over \$10,000,000)

**Other [Specify]**

**REQUIRED BONDS**

**Bid Bond**

A Bid Bond in the amount of \$\_\_\_\_\_ or \_\_\_\_\_% of the total offer. Bid bond shall be submitted with the sealed response and shall include project name, location, and / or address and project number. In lieu of the bond, the bidder may file an alternative form of security in the amount of \$\_\_\_\_\_ or \_\_\_\_\_% of the total offer. in the form of a money order, a certified check, a cashier's check, or an irrevocable letter of credit issued to Manatee County. NOTE: A construction project over \$200,000 requires a Bid Bond in the amount of 5% of the total bid offer.

**Payment and Performance Bond**

A Payment and Performance Bond shall be submitted by Successful Bidder for 100% of the

award amount and shall be presented to Manatee County within ten (10) calendar days of issuance of the notice of intent to award. NOTE: A construction project over \$200,000 requires a Payment and Performance Bond.

## ***I. INSURANCE REQUIREMENTS***

### **THE POLICIES ARE TO CONTAIN, OR BE ENDORSED TO CONTAIN, THE FOLLOWING PROVISIONS:**

#### **Commercial General Liability and Automobile Liability Coverages**

- a. **“Manatee County, a Political Subdivision of the State of Florida,” is to be named as an Additional Insured in respect to:** Liability arising out of activities performed by or on behalf of the CONTRACTOR, his agents, representatives, and employees; products and completed operations of the CONTRACTOR; or automobiles owned, leased, hired or borrowed by the CONTRACTOR. The coverage shall contain no special limitation(s) on the scope of protection afforded to the COUNTY, its officials, employees or volunteers.

In addition to furnishing a Certificate of Insurance, the CONTRACTOR shall provide the endorsement that evidences Manatee COUNTY being listed as an Additional Insured. This can be done in one of two ways: (1) an endorsement can be issued that specifically lists “Manatee County, a Political Subdivision of the State of Florida,” as Additional Insured; or, (2) an endorsement can be issued that states that all Certificate Holders are Additional Insured with respect to the policy.

- b. The CONTRACTOR'S insurance coverage shall be primary insurance with respect to the COUNTY, its officials, employees and volunteers. Any insurance or self-insurance maintained by the COUNTY, its officials, employees or volunteers shall be excess of CONTRACTOR's insurance and shall be non-contributory.
- c. The insurance policies must be on an occurrence form.

#### **Workers' Compensation and Employers' Liability Coverages**

The insurer shall agree to waive all rights of subrogation against the COUNTY, its officials, employees and volunteers for losses arising from work performed by the CONTRACTOR for the COUNTY.

## ***II. General Insurance Provisions Applicable To All Policies:***

- a. Prior to the execution of contract, or issuance of a Purchase Order, and then annually upon the anniversary date(s) of the insurance policy's renewal date(s) for as long as this contract remains in effect, CONTRACTOR shall furnish the COUNTY with a

Certificate(s) of Insurance (using an industry accepted certificate form, signed by the Issuer, with applicable endorsements, and containing the solicitation or contract number, and title or description) evidencing the coverage set forth above and naming “Manatee County, a Political Subdivision of the State of Florida” as an Additional Insured on the applicable coverage(s) set forth above.

- b. If the policy contains an aggregate limit, confirmation is needed in writing (letter, email, etc.) that the aggregate limit has not been eroded to procurement representative when supplying Certificate of Insurance.

In addition, when requested in writing from the COUNTY, CONTRACTOR will provide the COUNTY with a certified copy of all applicable policies. The address where such certificates and certified policies shall be sent or delivered is as follows:

**Manatee County, a Political Subdivision of the State of Florida**  
**Attn: Risk Management Division**  
**1112 Manatee Avenue West, Suite 969**  
**Bradenton, FL 34205**

- c. The project’s solicitation number and title shall be listed on each certificate.
- d. CONTRACTOR shall provide thirty (30) days written notice to the Risk Manager of any cancellation, non-renewal, termination, material change, or reduction in coverage of any insurance policies to procurement representative including solicitation number and title with all notices.
- e. CONTRACTOR agrees that should at any time CONTRACTOR fail to meet or maintain the required insurance coverage(s) as set forth herein, the COUNTY may terminate this contract.
- f. The CONTRACTOR waives all subrogation rights against COUNTY, a Political Subdivision of the State of Florida, for all losses or damages which occur during the contract and for any events occurring during the contract period, whether the suit is brought during the contract period or not.
- g. The CONTRACTOR has sole responsibility for all insurance premiums and policy deductibles.
- h. It is the CONTRACTOR'S responsibility to ensure that his agents, representatives and subcontractors comply with the insurance requirements set forth herein. CONTRACTOR shall include his agents, representatives, and subcontractors working on the project or at the worksite as insured under its policies, or CONTRACTOR shall furnish separate certificates and endorsements for each agent, representative, and subcontractor working on the project or at the worksite. All coverages for agents, representatives, and subcontractors shall be subject to all of the requirements set forth to the procurement representative.

- i. All required insurance policies must be written with a carrier having a minimum A.M. Best rating of A- FSC VII or better. In addition, the COUNTY has the right to review the CONTRACTOR's deductible or self-insured retention and to require that it be reduced or eliminated.
- j. CONTRACTOR understands and agrees that the stipulated limits of coverage listed herein in this insurance section shall not be construed as a limitation of any potential liability to the COUNTY, or to others, and the COUNTY'S failure to request evidence of this insurance coverage shall not be construed as a waiver of CONTRACTOR'S obligation to provide and maintain the insurance coverage specified.
- k. CONTRACTOR understands and agrees that the COUNTY does not waive its immunity and nothing herein shall be interpreted as a waiver of the COUNTY'S rights, including the limitation of waiver of immunity, as set forth in Florida Statutes 768.28, or any other statutes, and the COUNTY expressly reserves these rights to the full extent allowed by law.
- l. No award shall be made until the Procurement Division has received the Certificate of Insurance in accordance with this section.

### ***III. BONDING REQUIREMENTS***

**Bid Bond/Certified Check.** By submitting a proposal, the CONTRACTOR agrees should its proposal be accepted, **to execute the form of Agreement and present the same to COUNTY for approval within ten (10) calendar days after notice of intent to award.** The CONTRACTOR further agrees that failure to execute and deliver said form of Agreement **within ten (10) calendar days** will result in damages to COUNTY and as guarantee of payment of same a bid bond/certified check shall be enclosed within the submitted sealed proposal in the amount of five (5%) percent of the total amount of the proposal. The CONTRACTOR further agrees that in case the CONTRACTOR fails to enter into an Agreement, as prescribed by COUNTY, the bid bond/certified check accompanying the proposal shall be forfeited to COUNTY as agreed liquidated damages. If COUNTY enters into an agreement with a CONTRACTOR, or if COUNTY rejects any and/or all proposals, accompanying bond will be promptly returned.

**Payment and Performance Bonds.** Prior to commencing work, the CONTRACTOR shall obtain, for the benefit of and directed to COUNTY, a Payment and Performance Bond satisfying the requirements of Section 255.05, Florida Statutes, covering the faithful performance by the CONTRACTOR of its obligation under the Contract Documents, including but not limited to the construction of the project on the project site and the payment and obligations arising thereunder, including all payments to Subcontractors, laborers, and materialmen. The surety selected by the CONTRACTOR to provide the Payment and Performance Bond shall be approved by COUNTY prior to issuance of such Bond, which approval shall not be unreasonably withheld or delayed provided that surety is rated A- or better by Best's Key Guide, latest edition.



Failure to provide the required bonds on the prescribed form may result in CONTRACTOR being deemed nonresponsive. Bonds must be in the form prescribed in Section 255.05, Florida Statutes, and must not contain notice, demand or other terms and conditions, including **informal** pre-claim meetings, not provided for in Section 255.05, Florida Statutes.

Bonds shall be in an amount equal to 100% of the contract price issued by a duly authorized and nationally recognized surety company, authorized to do business in the State of Florida, satisfactory to COUNTY. Surety shall be rated as “A-” or better by Best’s Key Guide, latest edition. **The** attorney-in-fact who signs the bonds must file with the bonds, a certificate and effective dated copy of power-of-attorney. Payment and Performance Bonds shall be issued to “Manatee County, a political subdivision of the State of Florida”, **within ten (10) calendar days after issuance of notice of intent to award.**

In addition, pursuant to Section 255.05(1)(b), Florida Statutes, prior to commencing work, the CONTRACTOR shall be responsible and bear all costs associated to record the Payment and Performance Bond with the Manatee County Clerk of the Circuit Court. A certified copy of said recording shall be furnished to the Procurement Division upon filing. Pursuant to Section 255.05(1)(b), Florida Statutes, COUNTY will make no payment to the CONTRACTOR until the CONTRACTOR has complied with this paragraph.

Furnishing Payment and Performance Bonds shall be requisite to execution of an Agreement with COUNTY. Said Payment and Performance Bonds will remain in force for the duration of this Agreement with the premiums paid by the CONTRACTOR. Failure of the CONTRACTOR to execute such Agreement and to supply the required bonds shall be just cause for cancellation of the award. COUNTY may then contract with the next lowest, responsive and responsible CONTRACTOR or re-advertise this RFP.

Failure of COUNTY at any time to require performance by the CONTRACTOR of any provisions set out in the resulting Agreement will in no way affect the right of COUNTY, thereafter, to enforce those provisions.

[Remainder of page intentionally left blank]

**CONTRACTOR’S INSURANCE STATEMENT**

**THE UNDERSIGNED** has read and understands the aforementioned insurance and bond requirements of this Agreement and shall provide the insurance required by this section within ten (10) days from the date of notice of intent to award.

Date: \_\_\_\_\_

Contractor’s Name: \_\_\_\_\_

Authorized Signature: \_\_\_\_\_

Printed Name/Title: \_\_\_\_\_

Insurance Agency: \_\_\_\_\_

Agent Name: \_\_\_\_\_

Agent Phone: \_\_\_\_\_

Surety Agency: \_\_\_\_\_

Surety Name: \_\_\_\_\_

Surety Phone: \_\_\_\_\_

*Please return this completed and signed statement with your agreement.*

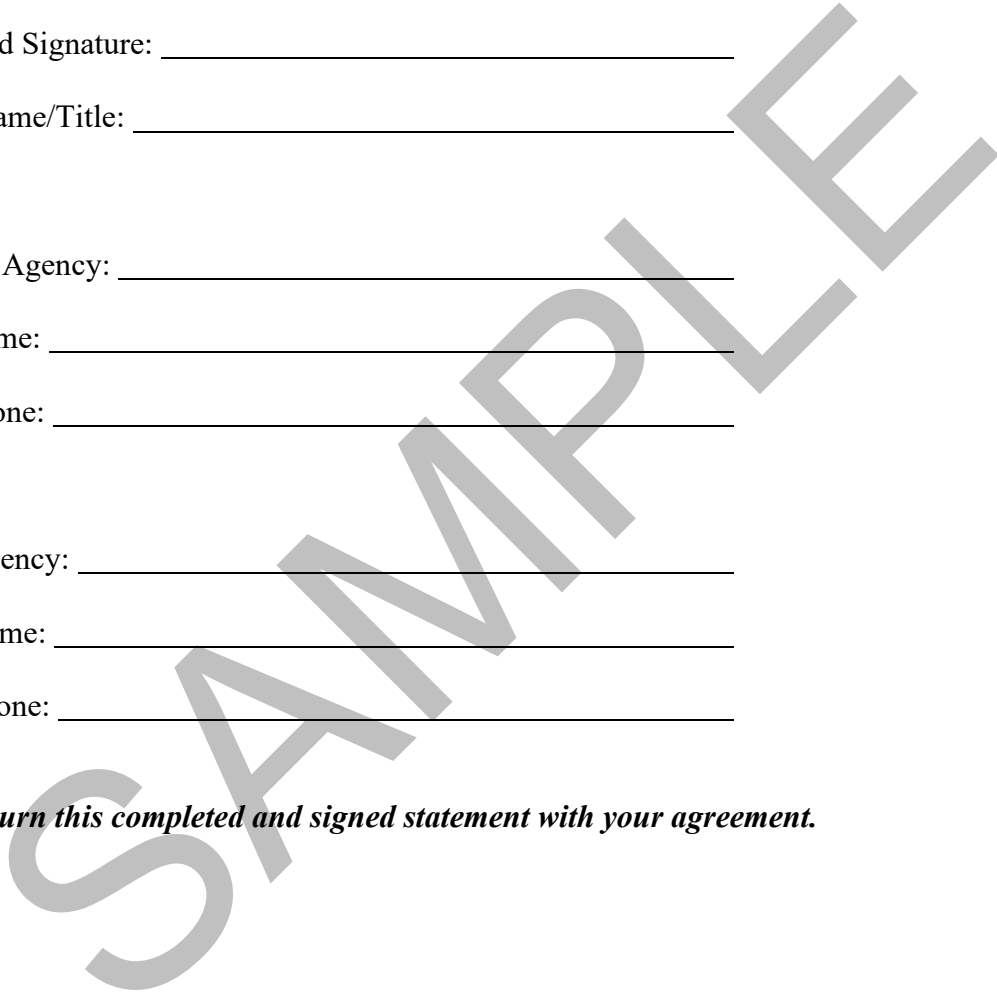

GENERAL CONDITIONS  
*of the*  
CONSTRUCTION AGREEMENT

**TABLE OF CONTENTS FOR GENERAL CONDITIONS**

	<b><u>Page</u></b>
<b>ARTICLE I -- DEFINITIONS .....</b>	<b>GC-1</b>
1.1 Definitions .....	GC-1
A. Acceptance .....	GC-1
B. Application for Payment .....	GC-1
C. Architect/Engineer .....	GC-1
D. Change Order .....	GC-1
E. Construction Services.....	GC-1
F. Construction Team.....	GC-1
G. Contract Sum.....	GC-1
H. Contract Time .....	GC-1
I. Contractor’s Personnel.....	GC-1
J. Days .....	GC-1
K. Defective .....	GC-1
L. Field Directive.....	GC-2
M. Final Completion Date .....	GC-2
N. Float Time.....	GC-2
O. Force Majeure .....	GC-2
P. Notice to Proceed .....	GC-2
Q. Owner.....	GC-2
R. Owner’s Project Representative .....	GC-2
S. Payment and Performance Bond .....	GC-2
T. Permitting Authority .....	GC-2
U. Procurement Ordinance.....	GC-2
V. Progress Report .....	GC-2
W. Project .....	GC-3
X. Project Costs .....	GC-3
Y. Project Manager .....	GC-3
Z. Project Plans and Specifications .....	GC-3
AA. Project Schedule.....	GC-3
BB. Project Site .....	GC-3
CC. Subcontractor .....	GC-3
DD. Substantial Completion and Substantially Complete .....	GC-3
EE. Substantial Completion Date.....	GC-3
FF. Substitute.....	GC-3
GG. Unit Price Work .....	GC-4

HH.	Work .....	GC-4
II.	Work Directive Change.....	GC-4

**ARTICLE II – RELATIONSHIP AND RESPONSIBILITIES..... GC-4**

2.1	Relationship between Contractor and Owner .....	GC-4
A.	Purpose.....	GC-4
B.	Construction Team.....	GC-4
C.	Owner’s Reliance on Bid (or Guaranteed Maximum Price Addendum).....	GC-5
2.2	General Contractor Responsibilities .....	GC-5
A.	Personnel.....	GC-5
B.	Cooperation with Architect/Engineer.....	GC-5
C.	Timely Performance.....	GC-5
D.	Duty to Defend Work.....	GC-5
E.	Trade and Industry Terminology.....	GC-5
2.3	Project Schedule .....	GC-6
2.4	Construction Services .....	GC-6
A.	Construction of Project .....	GC-6
B.	Notice to Proceed .....	GC-7
C.	Quality of Work .....	GC-7
D.	Materials.....	GC-7
E.	Accountability for Work.....	GC-7
F.	Contract Sum.....	GC-7
G.	Governing Specifications .....	GC-7
H.	Adherence to Project Schedule .....	GC-8
I.	Superintendent .....	GC-8
J.	Work Hours.....	GC-8
K.	Overtime-Related Costs .....	GC-8
L.	Insurance, Overhead and Utilities .....	GC-8
M.	Cleanliness .....	GC-9
N.	Loading .....	GC-9
O.	Safety and Protection .....	GC-9
P.	Emergencies .....	GC-9
Q.	Substitutes .....	GC-9
R.	Surveys and Stakes.....	GC-10
S.	Suitability of Project Site .....	GC-10
T.	Project Specification Errors .....	GC-11
U.	Remediation of Contamination .....	GC-11
V.	Interfacing.....	GC-12
W.	Job Site Facilities .....	GC-12

X.	Weather Protection.....	GC-13
Y.	Payment and Performance Bond.....	GC-13
Z.	Construction Phase; Building Permit; Code Inspections.....	GC-13
(1)	Building Permit.....	GC-13
(2)	Code Inspections.....	GC-13
(3)	Contractor’s Personnel.....	GC-14
(4)	Lines of Authority.....	GC-14
AA.	Quality Control.....	GC-14
BB.	Management of Subcontractors.....	GC-14
CC.	Job Requirements.....	GC-15
DD.	As-Built Drawings.....	GC-16
EE.	Progress Reports.....	GC-16
FF.	Contractor’s Warranty.....	GC-17
GG.	Apprentices.....	GC-17
HH.	Schedule of Values.....	GC-17
II.	Other Contracts.....	GC-17
<b>ARTICLE III -- COMPENSATION.....</b>		<b>GC-18</b>
3.1	Compensation.....	GC-18
A.	Adjustments.....	GC-18
B.	Valuation.....	GC-18
C.	Unit Price Work.....	GC-18
3.2	Schedule of Compensation.....	GC-19
A.	Periodic Payments for Services.....	GC-19
B.	Payment for Materials and Equipment.....	GC-19
C.	Credit toward Contract Sum.....	GC-19
3.3	Invoice and Payment.....	GC-19
A.	Invoices.....	GC-19
B.	Additional Information; Processing of Invoices.....	GC-19
C.	Architect/Engineer’s Approval.....	GC-20
D.	Warrants of Contractor with Respect to Payments.....	GC-20
E.	All Compensation Included.....	GC-20
<b>ARTICLE IV-- SUBCONTRACTORS.....</b>		<b>GC-20</b>
4.1	Subcontracts.....	GC-20
A.	Subcontracts Generally.....	GC-20
B.	No Damages for Delay.....	GC-21
C.	Subcontractual Relations.....	GC-21
D.	Insurance; Acts and Omissions.....	GC-21

4.2	Relationship and Responsibilities.....	GC-21
4.3	Payments to Subcontractors; Monthly Statements .....	GC-22
A.	Payment.....	GC-22
B.	Final Payment of Subcontractors .....	GC-22
4.4	Responsibility for Subcontractors.....	GC-22
4.5	Contingent Assignment of Subcontracts .....	GC-22
<b>ARTICLE V – CHANGES IN WORK.....</b>		<b>GC-23</b>
5.1	General .....	GC-23
5.2	Minor Changes in the Work .....	GC-23
5.3	Emergencies .....	GC-23
5.4	Concealed Conditions.....	GC-23
5.5	Hazardous Materials.....	GC-24
5.6	Change Orders; Adjustments to Contract Sum.....	GC-24
A.	Change Orders Generally.....	GC-24
5.7	Owner-Initiated Changes.....	GC-25
5.8	Unauthorized Work .....	GC-25
5.9	Defective Work .....	GC-25
5.10	Estimates for Changes .....	GC-25
5.11	Form of Proposed Changes.....	GC-25
5.12	Changes to Contract Time .....	GC-25
<b>ARTICLE VI – ROLE OF ARCHITECT/ENGINEER.....</b>		<b>GC-26</b>
6.1	General .....	GC-26
A.	Retaining .....	GC-26
B.	Duties .....	GC-26
C.	Termination.....	GC-26
6.2	Administration.....	GC-26
A.	Site Visits .....	GC-26
B.	Reporting.....	GC-27
6.3	Interpretation of Project Plans and Specifications.....	GC-27
6.4	Rejection of Non-Conforming Work.....	GC-27
6.5	Correction of Work.....	GC-27
6.6	Timely Performance of Architect/Engineer.....	GC-27
<b>ARTICLE VII – OWNER’S RIGHTS AND RESPONSIBILITIES.....</b>		<b>GC-27</b>
7.1	Project Site; Title .....	GC-28
7.2	Project Plans and Specifications; Architect/Engineer.....	GC-28
7.3	Surveys; Soil Tests and Other Project Site Information .....	GC-28

7.4	Information; Communication; Coordination .....	GC-28
7.5	Governmental Body.....	GC-29
7.6	Pre-Completion Acceptance.....	GC-29
7.7	Ownership and Use of Drawings, Specifications and Other Instruments of Service.....	GC-29
7.8	Owner’s Project Representative .....	GC-30
A.	Responsibilities .....	GC-30
B.	Limitations .....	GC-30
<b>ARTICLE VIII – RESOLUTION OF DISAGREEMENTS; CLAIMS FOR COMPENSATION .....</b>		<b>GC-31</b>
8.1	Owner to Decide Disputes.....	GC-31
8.2	Finality.....	GC-31
8.3	No Damages for Delay .....	GC-31
8.4	Permitted Claims Procedure .....	GC-31
8.5	Contract Claims and Disputes .....	GC-32
8.6	Claims for Consequential Damages.....	GC-32
<b>ARTICLE IX-- INDEMNITY .....</b>		<b>GC-33</b>
9.1	Indemnity.....	GC-33
A.	Indemnification Generally.....	GC-33
B.	Indemnification; Enforcement Actions .....	GC-33
C.	Claims by Employees.....	GC-33
9.2	Duty to Defend .....	GC-34
<b>ARTICLE X – ACCOUNTING RECORDS; OWNERSHIP OF DOCUMENTS.....</b>		<b>GC-34</b>
10.1	Accounting Records .....	GC-34
10.2	Inspection and Audit.....	GC-34
10.3	Access.....	GC-34
10.4	Ownership of Documents .....	GC-34
<b>ARTICLE XI – PUBLIC CONTRACT LAWS .....</b>		<b>GC-35</b>
11.1	Equal Opportunity Employment.....	GC-35
A.	Employment .....	GC-35
B.	Participation .....	GC-35
11.2	Immigration Reform and Control Act of 1986 .....	GC-35
11.3	No Conflict of Interest.....	GC-354
A.	No Interest in Business Activity.....	GC-35
B.	No Appearance of Conflict .....	GC-35
11.4	Truth in Negotiations.....	GC-36
11.5	Public Entity Crimes.....	GC-36



**ARTICLE XII – FORCE MAJEURE, FIRE OR OTHER CASUALTY ..... GC-36**

12.1 Force Majeure.....GC-36

    A. Unavoidable Delays .....GC-3665

    B. Concurrent Contractor Delays.....GC-36

    C. Notice; Mitigation .....GC-36

12.2 Casualty; Actions by Owner and Contractor .....GC-37

12.3 Approval of Plans and Specifications.....GC-37

12.4 Notice of Loss or Damage .....GC-37

**ARTICLE XIII – REPRESENTATIONS, WARRANTIES AND COVENANTS..... GC-38**

13.1 Representations and Warranties of Contractor .....GC-38

13.2 Representations of the Owner.....GC-40

**ARTICLE XIV—TERMINATION AND SUSPENSION..... GC-41**

14.1 Termination for Cause by Owner .....GC-41

    A. Nonperformance.....GC-41

    B. Insolvency .....GC-42

    C. Illegality .....GC-42

    D. Rights of Owner .....GC-42

14.2 Termination without Cause by Owner.....GC-42

    A. Release of Contractor.....GC-42

    B. Waiver of Protest.....GC-43

14.3 Suspension without Cause .....GC-43

14.4 Termination Based Upon Abandonment, Casualty or Force Majeure.....GC-43

14.5 Vacation of Project Site; Delivery of Documents .....GC-43

14.6 Termination by the Contractor .....GC-43

## GENERAL CONDITIONS

### ARTICLE I

#### DEFINITIONS

**1.1 Definitions.** For purposes of the Contract Documents, the following terms shall have the following meanings.

A. Acceptance: The acceptance of the Project into the Owner's operating public infrastructure.

B. Application for Payment: The form approved and accepted by the Owner, which is to be used by Contractor in requesting progress payments or final payment and which is to include such supporting documentation as is required by the Contract Documents.

C. Architect/Engineer: \_\_\_\_\_, a \_\_\_\_\_ corporation or limited liability company, registered and licensed to do business in the State of Florida, OR \_\_\_\_\_, an employee of Owner.

D. Change Order: A written order signed by the Owner, the Architect/Engineer and the Contractor authorizing a change in the Project Plans and/or Specifications and, if necessary, a corresponding adjustment in the Contract Sum and/or Contract Time, pursuant to Article V.

E. Construction Services: The Construction Services to be provided by Contractor pursuant to Section 2.4, in accordance with the terms and provisions of the Contract Documents.

F. Construction Team: The working team established pursuant to Section 2.1.B.

G. Contract Sum: The total compensation to be paid to the Contractor for Construction Services rendered pursuant to the Contract Documents, as set forth in Contractor's Bid (or Guaranteed Maximum Price Addendum), unless adjusted in accordance with the terms of the Contract Documents

H. Contract Time: The time period during which all Construction Services are to be completed pursuant to the Contract Documents, to be set forth in the Project Schedule.

I. Contractor's Personnel: The Contractor's key personnel designated by Contractor.

J. Days: Calendar days except when specified differently. When time is referred to in the Contract Documents by days, it will be computed to exclude the first and include the last day of such period. If the last day of any such period falls on a Saturday or Sunday or legal holiday, such day will be omitted from the computation.

K. Defective: When modifying the term "Work", referring to Work that is unsatisfactory, faulty or deficient, or does not conform to the Contract Documents, or that does

not meet the requirements of any inspection, reference standard, test or approval referred to in the Contract Documents, or that has been damaged prior to Owner's approval of final payment (unless responsibility for the protection thereof has been assumed by Owner).

L. Field Directive: A written order issued by Owner which orders minor changes in the Work not involving a change in Contract Time, to be paid from the Owner's contingency funds.

M. Final Completion Date: The date upon which the Project is fully constructed and all Work required on the Project and Project Site is fully performed as verified in writing by the Owner.

N. Float Time: The time available in the Project Schedule during which an unexpected activity can be completed without delaying Substantial Completion of the Work.

O. Force Majeure: Those conditions constituting excuse from performance as described in and subject to the conditions described in Article XII.

P. Notice to Proceed: Written notice by Owner (after execution of Contract) to Contractor fixing the date on which the Contract Time will commence to run and on which Contractor shall start to perform the Work.

Q. Owner: Manatee County, a political subdivision of the State of Florida.

R. Owner's Project Representative: The individual designated by Owner to perform those functions set forth in Section 7.8.

S. Payment and Performance Bond: The Payment and Performance Bond security posted pursuant to Section 2.4.Y to guarantee payment and performance by the Contractor of its obligations hereunder.

T. Permitting Authority: Any applicable governmental authority acting in its governmental and regulatory capacity which is required to issue or grant any permit, certificate, license or other approval which is required as a condition precedent to the commencement or approved of the Work, or any part thereof, including the building permit.

U. Price quote: A written statement submitted by the Contractor in response to a Change Order requested or issued by the Owner, which sets forth the Contractor's proposed cost to perform the additional labor, materials, services, or other obligations required by the Change Order which includes the following: itemized costs complete with supporting breakdowns, unit prices, schedule impacts, and other documentation as requested by County staff.

V. Procurement Ordinance: The Manatee County Procurement Code, Chapter 2-26 of the Manatee County Code of Laws, as amended from time to time.

W. Progress Report: A report to Owner that includes all information required pursuant to the Contract Documents and submitted in accordance with Section 2.4.EE, hereof.

X. Project: The total construction of which the Work performed under the Contract Documents may be the whole or a part and which may include construction by Owner and by separate contractors. For the purposes of the Contract Documents, the term Project shall include all areas of proposed improvements and all areas which may reasonably be judged to have an impact on the Project.

Y. Project Costs: The costs incurred by the Contractor to plan, construct and equip the Project and included within, and paid as a component of, the Contract Sum.

Z. Project Manager: Subject to the prior written consent of Owner, the individual designated to receive notices on behalf of the Contractor, or such other individual designated by the Contractor, from time to time, pursuant to written notice in accordance with the Contract Documents.

AA. Project Plans and Specifications: The one hundred percent (100%) construction drawings and specifications prepared by the Architect/Engineer, and any changes, supplements, amendments or additions thereto approved by the Owner, which shall also include any construction drawings and final specifications required for the repair or construction of the Project, as provided herein.

BB. Project Schedule: The schedule and sequence of events for the commencement, progression and completion of the Project, developed pursuant to Section 2.3., as such schedule may be amended as provided herein.

CC. Project Site: The site depicted in the Project Plans and Specifications, inclusive of all rights of way, temporary construction easements or licensed or leased sovereign lands.

DD. Subcontractor: Any individual (other than a direct employee of the Contractor) or organization retained by Contractor to plan, construct or equip the Project pursuant to Article IV.

EE. Substantial Completion and Substantially Complete: The stage in the progress of the Work when the Work or designated portion thereof is sufficiently complete in accordance with the Contract Documents so that the Owner can occupy or utilize the Work for its intended use; provided, however, that as a condition precedent to Substantial Completion, the Owner has received all certificates of occupancy or completion and other permits, approvals, licenses, and other documents from any governmental authority which are necessary for the beneficial occupancy of the Project or any designated portion thereof.

FF. Substantial Completion Date: The date on which the Project or designated portion thereof is deemed to be Substantially Complete, as evidenced by receipt of (i) the Architect/Engineer's certificate of Substantial Completion, (ii) written Acceptance of the Project by the Owner, and (iii) approvals of any other authority as may be necessary or otherwise required.

GG. Substitute: Materials or equipment offered by the Contractor as an alternative to that set forth in the Project Plans and Specifications, where (i) the Project Plans and Specifications do not authorize an "approved equal", or (ii) the Owner, in its reasonable discretion,

determines that a pre-authorized “approved equal” will result in a substantial change to the Work because of cost, quality or other difference in comparison to the materials or equipment specified.

HH. Unit Price Work: Work to be paid for on the basis of unit prices.

II. Work: The term “Work” means the construction and services required by the Contract Documents, whether completed or partially completed, and includes all labor, materials, equipment and services provided or to be provided by the Contractor to fulfill the Contractor’s obligations. The Work may constitute the whole or a part of the Project.

JJ. Work Directive Change: A written directive to Contractor, issued on or after the effective date of the Agreement pursuant to Section 5.8 and signed by Owner’s Project Representative, ordering an addition, deletion or revision in the Work, or responding to differing or unforeseen physical conditions under which the Work is to be performed or responding to emergencies.

## ARTICLE II

### RELATIONSHIP AND RESPONSIBILITIES

**2.1 Relationship between Contractor and Owner.** The Contractor accepts the relationship of trust and confidence established with Owner pursuant to the Contract Documents. The Contractor shall furnish its best skill and judgment and cooperate with Owner and Owner’s Project Representative in furthering the interests of the Owner. The Contractor agrees to provide the professional services required to complete the Project consistent with the Owner’s direction and the terms of the Contract Documents. All services provided hereunder by Contractor, either directly or through Subcontractors, shall be provided in accordance with sound construction practices and applicable professional construction standards.

A. Purpose. The purpose of the Contract Documents is to provide for the provision of construction services for the Project on the Project Site by the Contractor, and construction of the Project by the Contractor in accordance with the Project Plans and Specifications. The further purpose of the Contract Documents is to define and delineate the responsibilities and obligations of the parties to the Contract Documents and to express the desire of all such parties to cooperate to accomplish the purposes and expectations of the Contract Documents.

B. Construction Team. The Contractor, Owner and Architect/Engineer shall be called the “Construction Team” and shall work together as a team commencing upon full execution of the Contract Documents through Substantial Completion. As provided in Section 2.2, the Contractor and Architect/Engineer shall work jointly through completion and shall be available thereafter should additional services be required. The Contractor shall provide leadership to the Construction Team on all matters relating to construction. The Contractor understands, acknowledges and agrees that the Architect/Engineer shall provide leadership to the Construction Team on all matters relating to design.

C. Owner's Reliance on Bid (or Guaranteed Maximum Price Addendum). The Contractor acknowledges that the representations, statements, information and pricing contained in its Bid (or Guaranteed Maximum Price Addendum) have been relied upon by the Owner and have resulted in the award of this Project to the Contractor.

**2.2 General Contractor Responsibilities.** In addition to the other responsibilities set forth herein, the Contractor shall have the following responsibilities pursuant to the Contract Documents:

A. Personnel. The Contractor represents that it has secured, or shall secure, all personnel necessary to perform the Work, none of whom shall be employees of the Owner. Primary liaison between the Contractor and the Owner shall be through the Owner's Project Representative and Contractor's Project Manager. All of the services required herein shall be performed by the Contractor or under the Contractor's supervision, and all personnel engaged in the Work shall be fully qualified and shall be authorized or permitted under law to perform such services.

B. Cooperation with Architect/Engineer. The Contractor's services shall be provided in conjunction with the services of the Architect/Engineer. In the performance of professional services, the Contractor acknowledges that time is critical for Project delivery. The Contractor acknowledges that timely construction utilizing the services of an Architect/Engineer and a Contractor requires maximum cooperation between all parties.

C. Timely Performance. The Contractor shall perform all services as expeditiously as is consistent with professional skill and care and the orderly progress of the Work, in accordance with the Project Schedule. Verification of estimated Project Schedule goals will be made as requested by the Owner.

D. Duty to Defend Work. In the event of any dispute between the Owner and any Permitting Authority that relates to the quality, completeness or professional workmanship of the Contractor's services or Work, the Contractor shall, at its sole cost and expense, cooperate with the Owner to defend the quality and workmanship of the Contractor's services and Work.

E. Trade and Industry Terminology. It is the intent of the Contract Documents to describe a functionally complete Project (or part thereof) to be constructed in accordance with the Contract Documents. Any Work, materials or equipment that may reasonably be inferred from the Contract Documents as being required to produce the intended result will be supplied whether or not specifically called for. When words which have a well-known technical or trade meaning are used to describe Work, materials, or equipment, such words shall be interpreted in accordance with that meaning. Reference to standard specifications, manuals or codes of any technical society, organization or association, or to the laws or regulations of any governmental authority, whether such reference be specific or by implication, shall mean the latest standard specification, manual, code or laws or regulations in effect at the time of opening of Bids (or at the time of execution of the Guaranteed Maximum Price Addendum), except as may be otherwise specifically stated. However, no provision of any referenced standard specification, manual or code (whether or not specifically incorporated by reference in the Contract Documents) shall be effective to change the duties and responsibilities of Owner or Contractor, or any of their agents or employees from those set forth in the Contract Documents. Computed dimensions shall govern over scaled dimensions.

**2.3 Project Schedule.** The Contractor, within ten (10) days after being awarded the Agreement, shall prepare and submit for the Owner's and Architect/Engineer's information a Contractor's construction schedule for the Work. The schedule shall not exceed time limits current under the Contract Documents, shall be revised at appropriate intervals as required by the conditions of the Work and Project, shall be related to the entire Project to the extent required by the Contract Documents, and shall provide for expeditious and practicable execution of Work.

- A. The Project Schedule shall show a breakdown of all tasks to be performed, and their relationship in achieving the completion of each phase of Work, subject to review of Owner and Architect/Engineer and approval or rejection by Owner. The Project Schedule shall show, at a minimum, the approximate dates on which each segment of the Work is expected to be started and finished, the proposed traffic flows during each month, the anticipated earnings by the Contractor for each month and the approximate number of crews and equipment to be used. The Project Schedule shall include all phases of procurement, approval of shop drawings, proposed Change Orders in progress, schedules for Change Orders, and performance testing requirements. The Project Schedule shall include a construction commencement date and Project Substantial Completion Date, which dates shall accommodate known or reasonably anticipated geographic, atmospheric and weather conditions.
- B. The Project Schedule shall serve as the framework for the subsequent development of all detailed schedules. The Project Schedule shall be used to verify Contractor performance and to allow the Owner's Project Representative to monitor the Contractor's efforts.
- C. The Project Schedule may be adjusted by the Contractor pursuant to Article V. The Owner shall have the right to reschedule Work provided such rescheduling is in accord with the remainder of terms of the Contract Documents.
- D. The Contractor shall prepare a submittal schedule, promptly after being awarded the Agreement and thereafter as necessary to maintain a current submittal schedule, and shall submit the schedule(s) for the Architect/Engineer's approval. The Architect/Engineer's approval shall not be unreasonably delayed or withheld. The submittal schedule shall (1) be coordinated with the Contractor's construction schedule, and (2) allow the Architect/Engineer reasonable time to review submittals. If the Contractor fails to submit a submittal schedule, the Contractor shall not be entitled to any increase in Contract Sum or extension of Contract Time based on the time required for review of submittals.
- E. The Contractor shall perform the Work in general accordance with the most recent schedules submitted to the Owner and Architect/Engineer.

**2.4 Construction Services.** The Contractor shall provide the following Construction Services:

- A. Construction of Project. The Contractor shall work from the receipt of a Notice to Proceed through the Substantial Completion of the Project in accordance with the terms

of the Contract Documents to manage the construction of the Project. The Construction Services provided by the Contractor to construct the Project shall include without limitation (1) all services necessary and commensurate with established construction standards, and (2) all services described in the Invitation for Bid (or Request for Proposal) and the Bid (or Guaranteed Maximum Price Addendum).

B. Notice to Proceed. A Notice to Proceed may be given at any time within thirty (30) days after the effective date of the Agreement. Contractor shall start to perform the Work on the date specified in the Notice to Proceed, but no Work shall be done at the site prior to the issuance of the Notice to Proceed.

C. Quality of Work. If at any time the labor used or to be used appears to the Owner as insufficient or improper for securing the quality of Work required or the required rate of progress, the Owner may order the Contractor to increase its efficiency or to improve the character of its Work, and the Contractor shall conform to such an order. Any such order shall not entitle Contractor to any additional compensation or any increase in Contract Time. The failure of the Owner to demand any increase of such efficiency or any improvement shall not release the Contractor from its obligation to secure the quality of Work or the rate of progress necessary to complete the Work within the limits imposed by the Contract Documents. The Owner may require the Contractor to remove such personnel as the Owner deems incompetent, careless, insubordinate or otherwise objectionable, or whose continued employment on the Project is deemed to be contrary to the Owner's interest. The Contractor shall provide good quality workmanship and shall promptly correct construction defects without additional compensation. Acceptance of the Work by the Owner shall not relieve the Contractor of the responsibility for subsequent correction of any construction defects.

D. Materials. All materials and equipment shall be of good quality and new, except as otherwise provided in the Contract Documents. If required by Architect/Engineer, Contractor shall furnish satisfactory evidence (including reports of required tests) as to the kind and quality of materials and equipment. All materials and equipment shall be applied, installed, connected, erected, used, cleaned and conditioned in accordance with the instruction of the applicable supplier except as otherwise provided in the Contract Documents.

E. Accountability for Work. The Contractor shall be solely accountable for its Work, including plans review and complete submittals. The Contractor shall be solely responsible for means, methods, techniques, sequences and procedures of construction. If a specific means, method, technique, sequence or procedure of construction is required by the Contract Documents, the Contractor may utilize an alternative means, method, technique, sequence or procedure acceptable to the Architect/Engineer if the Contractor submits sufficient information to allow the Architect/Engineer to determine that the alternative is equivalent to that required by the Contract Documents.

F. Contract Sum. The Contractor shall construct the Project so that the Project can be built for a cost not to exceed the Contract Sum.

G. Governing Specifications. In the absence of specified Owner design standards or guidelines, the Architect/Engineer shall use, and the Contractor shall comply with, the most recent version of the applicable FDOT or AASHTO design standards. In general, the Project shall be constructed by the Contractor in accordance with applicable industry standards.



The Contractor shall be responsible for utilizing and maintaining current knowledge of any laws, ordinances, codes, rules, regulations, standards, guidelines, special conditions, specifications or other mandates relevant to the Project or the services to be performed.

H. Adherence to Project Schedule. The development and equipping of the Project shall be undertaken and completed in accordance with the Project Schedule, and within the Contract Time described therein.

I. Superintendent. The Contractor shall employ a competent superintendent and necessary assistants who shall be in attendance at the Project Site during performance of the Work. The superintendent shall represent the Contractor, and communications given to the superintendent shall be as binding as if given to the Contractor.

(1) The Contractor, as soon as practicable after award of the Agreement, shall furnish in writing to the Owner through the Architect/Engineer the name and qualifications of the proposed superintendent. The Architect/Engineer may reply within 14 days to the Contractor in writing stating (1) whether the Owner or the Architect/Engineer has reasonable objection to the proposed superintendent or (2) that the Architect/Engineer requires additional time to review. Failure of the Architect/Engineer to reply within 14 days shall constitute notice of no reasonable objection.

(2) The Contractor shall not employ a proposed superintendent to whom the Owner or Architect/Engineer has made reasonable and timely objection. The Contractor shall not change the superintendent without the Owner's consent, which shall not be unreasonably withheld or delayed.

J. Work Hours. Contractor shall provide competent, suitable qualified personnel to survey and lay out the Work and perform construction as required by the Contract Documents. Contractor shall at all times maintain good discipline and order at the site. Except in connection with the safety or protection of persons or the Work or property at the site or adjacent thereto and except as otherwise indicated in the Contract Documents, all Work at the site shall be performed during regular working hours, and Contractor shall not permit overtime work or the performance of Work on a Saturday, Sunday or legal holiday without Owner's written consent given after prior notice to Architect/Engineer (at least seventy-two (72) hours in advance).

K. Overtime-Related Costs. Contractor shall pay for all additional Architect/Engineer charges, inspection costs and Owner staff time for any overtime work which may be authorized. Such additional charges shall be an obligation of Contractor and no extra payment shall be made by Owner because such overtime work. At Owner's option, such overtime costs may be deducted from Contractor's monthly payment request or Contractor's retainage prior to release of final payment. Contractor's obligation to pay all overtime-related costs shall not apply if Contractor is directed by Owner to work overtime solely for Owner's convenience.

L. Insurance, Overhead and Utilities. Unless otherwise specified, Contractor shall furnish and assume full responsibility for all bonds, insurance, materials, equipment, labor, transportation, construction equipment and machinery, tools, appliances, fuel, power, light, heat, telephone, water, sanitary facilities, temporary facilities and all other facilities and incidentals necessary for the furnishing, performance, testing, start-up and completion of the Work.

M. Cleanliness. The Contractor shall keep the premises and surrounding area free from accumulation of waste materials or rubbish caused by operations under the Contract. At completion of the Work, the Contractor shall remove waste materials, rubbish, the Contractor's tools, construction equipment, machinery and surplus materials from and about the Project Site. Contractor shall restore to original conditions all property not designated for alteration by the Contract Documents. If the Contractor fails to clean up as provided in the Contract Documents, the Owner may do so and Owner shall be entitled to reimbursement from Contractor.

N. Loading. Contractor shall not load nor permit any part of any structure to be loaded in any manner that will endanger the structure, nor shall Contractor subject any part of the Work or adjacent property to stresses or pressures that will endanger it.

O. Safety and Protection. Contractor shall comply with all applicable federal, state and local safety regulations. Contractor shall be responsible for initiating, maintaining and supervising all safety precautions and programs in connection with the Work. Contractor shall take all necessary precautions for the safety of and shall provide the necessary protection to prevent damage, injury or loss to:

- (1) All employees on the Work and other persons and organizations who may be affected thereby;
- (2) All the Work and materials and equipment to be incorporated therein, whether in storage on or off the Project Site; and
- (3) Other property at the Project Site or adjacent thereto, including trees, shrubs, lawns, walks, pavements, roadways, structures, utilities and underground facilities not designated for removal, relocation or replacement during construction.

Contractor shall comply with all applicable laws and regulations of any public body having jurisdiction for the safety of persons or property or to protect them from damage, injury or loss, and shall erect and maintain all necessary safeguards for such safety and protection. Contractor shall provide and maintain all passageways, guard fences, lights and other facilities for the protection required by public authority or local conditions. Contractor shall provide reasonable maintenance of traffic for the public and preservation of the Owner's business, taking into full consideration all local conditions. Contractor's duties and responsibilities for safety and protection with regard to the Work shall continue until such time as all the Work is completed.

P. Emergencies. In emergencies affecting the safety or protection of persons or the Work or property at the Project Site or adjacent thereto, Contractor, without special instruction or authorization from Architect/Engineer or Owner, shall act to prevent threatened damage, injury or loss. Contractor shall give Owner prompt written notice if Contractor believes that any significant changes in the Work or variations from the Contract Documents have been caused thereby. If Owner determines that a change in the Project is required because of the action taken in response to an emergency, a Work Directive Change or Change Order will be issued to document the consequences of the changes or variation.

Q. Substitutes. For Substitutes not included with the Bid (or Guaranteed Maximum Price Addendum), but submitted after the effective date of the Agreement (or

Guaranteed Maximum Price Addendum), Contractor shall make written application to Architect/Engineer for acceptance thereof, certifying that the proposed Substitute will perform adequately the functions and achieve the results called for by the general design, be similar and of equal substance to that specified and be suited to the same use as that specified. The application will also contain an itemized estimate of all costs and delays or schedule impacts that will result directly or indirectly from review, acceptance and provision of such Substitute, including costs of redesign and claims of other contractors affected by the resulting change, all of which will be considered by the Architect/Engineer in evaluating the proposed Substitute. Architect/Engineer may require Contractor to furnish at Contractor's expense, additional data about the proposed Substitute. In rendering a decision, Owner, Architect/Engineer and Contractor shall have access to any available Float Time in the Project Schedule. If Substitute materials or equipment not included as part of the Bid (or Guaranteed Maximum Price Addendum), but proposed after the effective date of the Agreement, are accepted and are less costly than the originally specified materials or equipment, then the net difference in cost shall be credited to the Owner and an appropriate Change Order executed to adjust the Contract Sum.

- (1) Architect/Engineer will be allowed a reasonable time within which to evaluate each proposed Substitute. Architect/Engineer will be the sole judge of acceptability and no Substitute will be ordered, installed or utilized without Architect/Engineer's prior written acceptance which will be evidenced by either a Change Order or an approved shop drawing. Owner may require Contractor to furnish at Contractor's expense a special performance guarantee or other surety with respect to any Substitute.
- (2) Contractor shall reimburse Owner for the charges of Architect/Engineer and Architect/Engineer's Consultants for evaluating each proposed Substitute submitted after the effective date of the Agreement and all costs resulting from any delays in the Work while the Substitute was undergoing review.

R. Surveys and Stakes. The Contractor shall furnish, as part of the Contract Sum, all labor, stakes, surveys, batter boards for structures, grade lines and other materials and supplies and shall set construction stakes and batter boards for establishing lines, position of structures, slopes and other controlling points necessary for the proper prosecution of the Work. Where rights-of-way, easements, property lines or any other conditions which make the lay-out of the Project or parts of the Project critical are involved, the Contractor shall employ a competent surveyor who is registered in the State of Florida for lay-out and staking. These stakes and marks shall constitute the field control by and in accord with which the Contractor shall govern and execute the Work. The Contractor shall be held responsible for the preservation of all stakes and marks and if for any reason any of the stakes or marks or batter boards become destroyed or disturbed, they shall be immediately and accurately replaced by the Contractor.

S. Suitability of Project Site. The Contractor has, by careful examination, satisfied itself as to the nature and location of the Work and all other matters which can in any way affect the Work, including, but not limited to details pertaining to borings, as shown on the drawings. Such boring information is not guaranteed to be more than a general indication of the materials likely to be found adjacent to holes bored at the Project Site, approximately at the locations indicated. The Contractor has examined boring data, where available, made its own interpretation of the subsurface conditions and other preliminary data, and has based its Bid (or Guaranteed Maximum Price Addendum) on its own opinion of the conditions likely to be

encountered. Except as specifically provided in Sections 2.4.U., 5.4 and 5.5, no extra compensation or extension of time will be considered for any Project Site conditions that existed at the time of bidding (or at the time of execution of the Guaranteed Maximum Price Addendum). No verbal agreement or conversation with any officer, agent or employee of the Owner, before or after the execution of the Agreement, shall affect or modify any of the terms or obligations herein contained.

T. Project Specification Errors. If the Contractor, during the Work, finds that the drawings, specifications or other Contract Documents cannot be followed, the Contractor shall immediately inform the Owner in writing, and the Owner shall promptly check the accuracy of the information. Any Work done after such discovery, until any necessary changes are authorized, will be done at the Contractor's sole risk of non-payment and delay.

U. Remediation of Contamination. Owner and Contractor recognize that remediation of subsurface conditions may be necessary due to potential hazardous materials contamination. Because the presence or extent of any contamination is not known, Contractor shall include no cost in the Contract Sum, and no time in the Project Schedule, for cost or delays that might result from any necessary remediation. The Project Schedule will provide a period of time between demolition activities and the start of the next activity to commence any remediation if needed. Contractor shall use all reasonable efforts in scheduling the Project to minimize the likelihood that remediation delays construction. Any hazardous materials remediation Work which Contractor agrees to perform shall be done pursuant to a Change Order or amendment consistent with the following:

- (1) The dates of Substantial Completion shall be equitably adjusted based on delays, if any, incurred in connection with remediation efforts.
- (2) Contractor, and any Subcontractors which have mobilized on the Project Site, shall be paid for demonstrated costs of overhead operations at the Project Site during any period of delay of more than seven (7) days, except to the extent that Work proceeds concurrently with remediation. The categories of costs to be reimbursed are limited to those reasonably incurred at the jobsite during the delay period (such as trailers or offices, telephones, faxes, and the like); equipment dedicated to the Project and located at the Project Site; salaries and associated costs of personnel dedicated to the Project to the extent that they do not perform work on other projects; and other jobsite costs that are reasonable and which are incurred during the delay period. Subcontractors and suppliers which have not mobilized are limited to the costs set forth in Section 2.4.U(3).
- (3) Contractor and any Subcontractor or supplier on the Project who is eligible for compensation shall be paid any demonstrated costs of escalation in materials or labor, and reasonable costs of off-site storage of materials identified to the Project, arising because of any delay of more than seven (7) days. Such Contractor, Subcontractors and suppliers are obligated to take all reasonable steps to mitigate escalation costs, such as through early purchase of materials.

- (4) Contractor, for itself and all Subcontractors and suppliers on the Project, hereby agrees that the extension of time for delays under Section 2.4.U(1), and payment of the costs identified in Sections 2.4.U(2) and/or Section 2.4.U(3), are the sole remedies for costs and delays described in this Section, and waives all claims and demands for extended home office overhead (including, but not limited to, "Eichleay" claims), lost profit or lost opportunities, and any special, indirect, or consequential damages arising as a result of delays described in this Section. The Contract Sum shall be adjusted to reflect payment of allowable costs.
- (5) If any delay described in this section causes the time or cost for the Project to exceed the Contract Time or the Contract Sum, then the Owner may terminate the Agreement pursuant to Section 14.2.
- (6) Contractor and any Subcontractor or supplier seeking additional costs under this Section 2.4.U. shall promptly submit estimates or any costs as requested by Owner, and detailed back-up for all costs when payment is sought or whenever reasonably requested by Owner. All costs are auditable, at Owner's discretion. Bid, estimate and pricing information reasonably related to any request for additional compensation will be provided promptly upon request.
- (7) Contractor shall include provisions in its subcontracts and purchase orders consistent with this Section.

V. Interfacing.

- (1) The Contractor shall take such measures as are necessary to ensure proper construction and delivery of the Project, including but not limited to providing that all procurement of long-lead items, the separate construction Subcontractors, and the general conditions items are performed without duplication or overlap to maintain completion of all Work on schedule. Particular attention shall be given to provide that each Subcontractor bid package clearly identifies the Work included in that particular separate subcontract, its scheduling for start and completion, and its relationship to other separate contractors.
- (2) Without assuming any design responsibilities of the Architect/Engineer, the Contractor shall include in the Progress Reports required under this Section 2.4 comments on overlap with any other separate subcontracts, omissions, lack of correlation between drawings, and any other deficiencies noted, in order that the Architect/Engineer may arrange for necessary corrections.

W. Job Site Facilities. The Contractor shall arrange for all job site facilities required and necessary to enable the Contractor and Architect/Engineer to perform their respective duties and to accommodate any representatives of the Owner which the Owner may choose to have present on the Project Site.

X. Weather Protection. The Contractor shall provide temporary enclosures of building areas to assure orderly progress of the Work during periods when extreme weather conditions are likely to be experienced. The Contractor shall also be responsible for providing weather protection for Work in progress and for materials stored on the Project Site. A contingency plan shall be prepared upon request of the Owner for weather conditions that may affect the construction.

Y. Payment and Performance Bond. Prior to the construction commencement date, the Contractor shall obtain, for the benefit of and directed to the Owner, a Payment and Performance Bond satisfying the requirements of Section 255.05, Florida Statutes, covering the faithful performance by the Contractor of its obligations under the Contract Documents, including but not limited to the construction of the Project on the Project Site and the payment of all obligations arising thereunder, including all payments to Subcontractors, laborers, and materialmen. The surety selected by the Contractor to provide the Payment and Performance Bond shall be approved by the Owner prior to the issuance of such Bond, which approval shall not be unreasonably withheld or delayed provided that the surety is rated A or better by Best's Key Guide, latest edition. For Changes in the Work that result in an increase in the Contract Sum, Owner reserves the right to require the Contractor to secure and deliver additive riders to the Payment and Performance Bond.

Z. Construction Phase; Building Permit; Code Inspections. Unless otherwise provided, Contractor shall obtain and pay for all construction permits and licenses. Owner shall assist Contractor, when necessary, in obtaining such permits and licenses. Contractor shall pay all governmental charges and inspection fees necessary for the prosecution of the Work.

- (1) Building Permit. The Owner and Architect/Engineer shall provide such information to any Permitting Authority as is necessary to obtain approval from the Permitting Authority to commence construction prior to beginning construction. The Contractor shall pull any required building permit, and shall be responsible for delivering and posting the building permit at the Project Site prior to the commencement of construction. The cost of the building permit is included in the Contract Sum. The Owner and Architect/Engineer shall fully cooperate with the Contractor when and where necessary.
- (2) Code Inspections. The Project requires detailed code compliance inspection during construction in disciplines determined by any Permitting Authority. These disciplines normally include, but are not necessarily limited to, structural, mechanical, electrical, plumbing, general building and fire. The Contractor shall notify the appropriate inspector(s) and the Architect/Engineer, no less than 24 hours in advance, when the Work is ready for inspection and before the Work is covered up. All inspections shall be made for conformance with the applicable ordinances and building codes. Costs for all re-inspections of Work found defective and subsequently repaired shall not be included as Project Costs and shall be borne by the Contractor or as provided in the contract between Contractor and Subcontractor.

- (3) Contractor's Personnel. The Contractor shall maintain sufficient off-site support staff and competent full-time staff at the Project Site authorized to act on behalf of the Contractor to coordinate, inspect, and provide general direction of the Work and progress of the Subcontractors. At all times during the performance of the Work, the Owner shall have the right to demand replacement of Contractor Personnel to whom the Owner has reasonable objection, without liability to the Contractor.
- (4) Lines of Authority. To provide general direction of the Work, the Contractor shall establish and maintain lines of authority for its personnel and shall provide this information to the Owner and all other affected parties, such as the code inspectors of any Permitting Authority, the Subcontractors, and the Architect/Engineer. The Owner and Architect/Engineer may attend meetings between the Contractor and his Subcontractors; however, such attendance is optional and shall not diminish either the authority or responsibility of the Contractor to administer the subcontracts.

AA. Quality Control. The Contractor shall develop and maintain a program, acceptable to the Owner and Architect/Engineer, to assure quality control of the construction. The Contractor shall be responsible for and supervise the Work of all Subcontractors, providing instructions to each when their Work does not conform to the requirements of the Project Plans and Specifications, and the Contractor shall continue to coordinate the Work of each Subcontractor to ensure that corrections are made in a timely manner so as to not affect the efficient progress of the Work. Should a disagreement occur between the Contractor and the Architect/Engineer over the acceptability of the Work, the Owner, at its sole discretion and in addition to any other remedies provided herein, shall have the right to determine the acceptability, provided that such determination is consistent with standards for construction projects of this type and generally accepted industry standards for workmanship in the State of Florida.

BB. Management of Subcontractors. All Subcontractors shall be compensated in accordance with Article IV. The Contractor shall solely control the Subcontractors. The Contractor shall negotiate all Change Orders and Field Orders with all affected Subcontractors and shall review the costs and advise the Owner and Architect/Engineer of their validity and reasonableness, acting in the Owner's best interest. When there is an imminent threat to health and safety, and Owner's Project Representative concurrence is impractical, the Contractor shall act immediately to remove the threats to health and safety and shall subsequently fully inform Owner of all such action taken. The Contractor shall also carefully review all shop drawings and then forward the same to the Architect/Engineer for review and actions. The Architect/Engineer will transmit them back to the Contractor, who will then issue the shop drawings to the affected Subcontractor for fabrication or revision. The Contractor shall maintain a suspense control system to promote expeditious handling. The Contractor shall request the Architect/Engineer to make interpretations of the drawings or specifications requested of him by the Subcontractors and shall maintain a business system to promote timely response. The Contractor shall inform the Architect/Engineer which shop drawings or requests for clarification have the greatest urgency, to enable the Architect/Engineer to prioritize requests coming from the Contractor. The Contractor shall advise the Owner and Architect/Engineer when timely response is not occurring on any of the above.

CC. Job Requirements.

- (1) The Contractor shall provide each of the following as a part of its services hereunder:
  - (a) Maintain a log of daily activities, including manpower records, equipment on site, weather, delays, major decisions, etc;
  - (b) Maintain a roster of companies on the Project with names and telephone numbers of key personnel;
  - (c) Establish and enforce job rules governing parking, clean-up, use of facilities, and worker discipline;
  - (d) Provide labor relations management and equal opportunity employment for a harmonious, productive Project;
  - (e) Provide and administer a safety program for the Project and monitor for subcontractor compliance without relieving them of responsibilities to perform Work in accordance with best acceptable practice;
  - (f) Provide a quality control program as provided under Section 2.4.C above;
  - (g) Provide miscellaneous office supplies that support the construction efforts which are consumed by its own forces;
  - (h) Provide for travel to and from its home office to the Project Site and to those other places within Manatee County as required by the Project;
  - (i) Verify that tests, equipment, and system start-ups and operating and maintenance instructions are conducted as required and in the presence of the required personnel and provide adequate records of same to the Architect/Engineer;
  - (j) Maintain at the job site orderly files for correspondence, reports of job conferences, shop drawings and sample submissions, reproductions of original Contract Documents including all addenda, change orders, field orders, additional drawings issued after execution of the Agreement, Owner/Architect/Engineer's clarifications and interpretations of the Contract Documents, Progress Reports, as-built drawings, and other project related documents;
  - (k) Keep a diary or log book, recording hours on the job site, weather conditions, data relative to questions of extras or deductions; list of visiting officials and representatives or manufacturers, fabricators,



suppliers and distributors; daily activities, decisions, observations in general and specific observations in more detail as in the case of observing test procedures, and provide copies of same to Owner/Architect/Engineer;

- (l) Record names, addresses and telephone numbers of all Contractors, Subcontractors and major suppliers of materials and equipment;
  - (m) Furnish Owner/Architect/Engineer periodic reports, as required, of progress of the Work and Contractor's compliance with the approved progress schedule and schedule of shop drawing submissions;
  - (n) Consult with Owner/Architect/Engineer in advance of scheduling major tests, inspections or start of important phases of the Work;
  - (o) Verify, during the course of the Work, that certificates, maintenance and operations manuals and other data required to be assembled and furnished are applicable to the items actually installed, and deliver same to Owner/Architect/Engineer for review prior to final Acceptance of the Work; and
  - (p) Cooperate with Owner in the administration of grants.
- (2) The Contractor shall provide personnel and equipment, or shall arrange for separate Subcontractors to provide each of the following as a Project Cost:
- (a) Services of independent testing laboratories, and provide the necessary testing of materials to ensure conformance to contract requirements; and
  - (b) Printing and distribution of all required bidding documents and shop drawings, including the sets required by Permitting Authority inspectors.

DD. As-Built Drawings. The Contractor shall continuously review as-built drawings and mark up progress prints to provide as much accuracy as possible. Prior to, and as a requirement for authorizing final payment to the Contractor due hereunder, the Contractor shall provide to the Owner an original set of marked-up, as-built Project Plans and Specifications and an electronic format of those records showing the location and dimensions of the Project as constructed, which documents shall be certified as being correct by the Contractor and the Architect/Engineer. Final as-built drawings shall be signed and sealed by a registered Florida surveyor.

EE. Progress Reports. The Contractor shall forward to the Owner, as soon as practicable after the first day of each month, a summary report of the progress of the various parts of the Work, to include those parts of the Work in fabrication and in the field, stating the existing status, estimated time of completion and cause of delay, if any. Together with the summary report, the Contractor shall submit any necessary revisions to the original schedule for the Owner's review

and approval. In addition, more detailed schedules may be required by the Owner for daily traffic control.

FF. Contractor's Warranty. The Contractor warrants to the Owner and Architect/Engineer that materials and equipment furnished under the Contract will be of good quality and new unless the Contract Documents require or permit otherwise. The Contractor further warrants that the Work will conform to the requirements of the Contract Documents and will be free from defects, except for those inherent in the quality of the Work the Contract Documents require or permit. Work, materials, or equipment not conforming to these requirements will be considered defective. The Contractor's warranty excludes remedy for damage or defect caused by abuse, alterations to the Work not executed by the Contractor, improper or insufficient maintenance, improper operation, or normal wear and tear and normal usage. If required by the Architect/Engineer, the Contractor shall furnish satisfactory evidence as to the kind and quality of materials and equipment.

- (1) Contractor shall use its best efforts and due diligence to ensure that during the warranty period, those entities or individuals who have provided direct warranties to the Owner as required by the Contract Documents perform all required warranty Work in a timely manner and at the sole cost and expense of such warranty providers. Any such cost or expense not paid by the warranty providers shall be paid by the Contractor, to include any costs and attorney's fees incurred in warranty-related litigation between Contractor and any Subcontractors.
- (2) The Contractor shall secure guarantees and warranties of Subcontractors, equipment suppliers and materialmen, and assemble and deliver same to the Owner in a manner that will facilitate their maximum enforcement and assure their meaningful implementation. The Contractor shall collect and deliver to the Owner any specific written guaranties or warranties given by others as required by subcontracts.
- (3) At the Owner's request, the Contractor shall conduct, jointly with the Owner and the Architect/Engineer, no more than two (2) warranty inspections within three (3) years after the Substantial Completion Date.

GG. Apprentices. If Contractor employs apprentices, their performance of Work shall be governed by and shall comply with the provisions of Chapter 446, Florida Statutes.

HH. Schedule of Values. Unit prices shall be established for this Agreement by the submission of a schedule of values within ten (10) days of receipt of the Notice to Proceed. The schedule shall include quantities and prices of items equaling the Contract Sum and will subdivide the Work into components in sufficient detail to serve as the basis for progress payments during construction. Such prices shall include an appropriate amount of overhead and profit applicable to each item of Work. Upon request of the County, the Contractor shall support the values with data which will substantiate their correctness.

II. Other Contracts. The Owner reserves the right to let other contracts in connection with this Work. The Contractor shall afford other contractors reasonable opportunity

for the introduction and storage of their materials and execution of their work, and promptly connect and coordinate the Work with theirs.

### ARTICLE III

#### COMPENSATION

**3.1 Compensation.** The Contract Sum constitutes the total compensation (subject to authorized adjustments) payable to Contractor for performing the Work. All duties, responsibilities and obligations assigned to or undertaken by Contractor shall be at Contractor's expense without change in the Contract Sum.

A. Adjustments. The Contract Sum may only be changed by Change Order or by a written amendment. Any claim for an increase or decrease in the Contract Sum shall be based on written notice delivered by the party making the claim to the other party. Notice of the amount of the claim with supporting data shall be delivered within fifteen (15) days from the beginning of such occurrence and shall be accompanied by claimant's written statement that the amount claimed covers all amounts to which the claimant is entitled as a result of the occurrence of said event. Failure to deliver a claim within the requisite 15-day period shall constitute a waiver of the right to pursue said claim. Notwithstanding any other provisions of the Contract Documents or herein to the contrary, if Owner receives from Contractor a price quote for a Change Order requested or issued by Owner, and the price quote conforms to all statutory requirements and contractual requirements of the Contract Documents and Project Plans and Specifications, Owner must approve or deny the price quote and send written notice of that decision to Contractor within thirty-five (35) days after receipt of such quote. Owner's denial notice must specify the alleged deficiencies in the price quote and the actions necessary to remedy those deficiencies. If Owner fails to provide Contractor with a notice in compliance with Section 218.755, Florida Statutes, the Change Order and price quote are deemed approved, and Owner must pay Contractor the amount stated in the price quote upon the completion of the Change Order.

B. Valuation. The value of any Work covered by a Change Order or of any claim for an increase or decrease in the Contract Sum shall be determined in one of the following ways (at Owner's discretion):

- (1) In the case of Unit Price Work, in accordance with Section 3.1.C, below; or
- (2) By mutual acceptance of a lump sum; or
- (3) On the basis of the cost of the Work, plus a negotiated Contractor's fee for overhead and profit. Contractor shall submit an itemized cost breakdown together with supporting data.

C. Unit Price Work. The unit price of an item of Unit Price Work shall be subject to re-evaluation and adjustment pursuant to a requested Change Order under the following conditions:

- (1) If the total cost of a particular item of Unit Price Work amounts to 5% or more of the Contract Sum and the variation in the quantity of the particular item of Unit Price Work performed by Contractor differs by more than 15% from the estimated quantity of such item indicated in the Agreement; and
- (2) If there is no corresponding adjustment with respect to any other item of Work; and
  - (i) If Contractor believes that it has incurred additional expense as a result thereof; or
  - (ii) If Owner believes that the quantity variation entitles it to an adjustment in the unit price; or
  - (iii) If the parties are unable to agree as to the effect of any such variations in the quantity of Unit Price Work performed.

**3.2 Schedule of Compensation.** All payments for services and material under the Contract Documents shall be made in accordance with the following provisions.

A. Periodic Payments for Services. The Contractor shall be entitled to receive payment for Construction Services rendered pursuant to Section 2.4 in periodic payments which shall reflect a fair apportionment of cost and schedule of values of services furnished prior to payment, subject to the provisions of this Section.

B. Payment for Materials and Equipment. In addition to the periodic payments authorized hereunder, payments may be made for material and equipment not incorporated in the Work but delivered and suitably stored at the Project Site, or another location, subject to prior approval and acceptance by the Owner on each occasion.

C. Credit toward Contract Sum. All payments for Construction Services made hereunder shall be credited toward the payment of the Contract Sum as Contractor's sole compensation for the construction of the Project.

**3.3 Invoice and Payment.** All payments for services and materials under the Contract Documents shall be invoiced and paid in accordance with the following provisions.

A. Invoices. The Contractor shall submit to the Owner periodic invoices for payment, in a form acceptable to the Owner, which shall include a sworn statement certifying that, to the best of the Contractor's knowledge, information and belief, the construction has progressed to the point indicated, the quality and the Work covered by the invoice is in accord with the Project Plans and Specifications, and the Contractor is entitled to payment in the amount requested, along with the cost reports required pursuant to Article II, showing in detail all monies paid out, Project Costs accumulated, or Project Cost incurred during the previous period. This data shall be attached to the invoice.

B. Additional Information; Processing of Invoices. Should an invoiced amount appear to exceed the Work effort believed to be completed, the Owner may, prior to

processing of the invoice for payment, require the Contractor to submit satisfactory evidence to support the invoice. All Progress Reports and invoices shall be delivered to the attention of the Owner's Project Representative. Invoices not properly prepared (mathematical errors, billing not reflecting actual Work done, no signature, etc.) shall be returned to the Contractor for correction.

C. Architect/Engineer's Approval. Payment for Work completed shall be subject to the Architect/Engineer approving the payment requested by the Contractor and certifying the amount thereof that has been properly incurred and is then due and payable to the Contractor, and identifying with specificity any amount that has not been properly incurred and that should not be paid.

D. Warrants of Contractor with Respect to Payments. The Contractor warrants that (1) upon payment of any retainage, materials and equipment covered by a partial payment request will pass to Owner either by incorporation in construction or upon receipt of payment by the Contractor, whichever occurs first; (2) Work, materials and equipment covered by previous partial payment requests shall be free and clear of liens, claims, security interests, or encumbrances; and (3) no Work, materials or equipment covered by a partial payment request which has been acquired by the Contractor or any other person performing Work at the Project Site, or furnishing materials or equipment for the Project, shall be subject to an agreement under which an interest therein or an encumbrance thereon is retained by the seller or otherwise imposed by the Contractor or any other person.

E. All Compensation Included. Contractor's compensation includes full payment for services set forth in the Contract Documents, including but not limited to overhead, profit, salaries or other compensation of Contractor's officers, partners and/or employees, general operating expenses incurred by Contractor and relating to this Project, including the cost of management, supervision and data processing staff, job office equipment and supplies, and other similar items.

## ARTICLE IV

### SUBCONTRACTORS

**4.1 Subcontracts.** At the Owner's request, the Contractor shall provide Owner's Project Representative with copies of all proposed and final subcontracts, including the general and supplementary conditions thereof.

A. Subcontracts Generally. All subcontracts shall: (1) require each Subcontractor to be bound to Contractor to the same extent Contractor is bound to Owner by the terms of the Contract Documents, as those terms may apply to the portion of the Work to be performed by the Subcontractor, (2) provide for the assignment of the subcontracts from Contractor to Owner at the election of Owner, upon termination of Contractor, (3) provide that Owner will be an additional indemnified party of the subcontract, (4) provide that Owner will be an additional insured on all insurance policies required to be provided by the Subcontractor, except workers' compensation, (5) assign all warranties directly to Owner, and (6) identify Owner as an intended third-party beneficiary of the subcontract.

(1) A Subcontractor is a person or entity who has a direct contract with Contractor to perform a portion of the Work at the site. The term “Subcontractor” is referred to throughout the Contract Documents as if singular in number and means a Subcontractor or an authorized representative of the Subcontractor. The term “Subcontractor” does not include a separate contractor or subcontractors of a separate contractor.

(2) A Sub-subcontractor is a person or entity who has a direct or indirect contract with a Subcontractor to perform a portion of the Work at the site. The term “Sub-subcontractor” is referred to throughout the Contract Documents as if singular in number and means a Sub-subcontractor or an authorized representative of the Sub-subcontractor.

B. No Damages for Delay. Except when otherwise expressly agreed to by Owner in writing, all subcontracts shall provide:

“LIMITATION OF REMEDIES – NO DAMAGES FOR DELAY. The Subcontractor's exclusive remedy for delays in the performance of the contract caused by events beyond its control, including delays claimed to be caused by the Owner or Architect/Engineer or attributable to the Owner or Architect/Engineer and including claims based on breach of contract or negligence, shall be an extension of its contract time and shall in no way involve any monetary claim.”

Each subcontract shall require that any claims by the Subcontractor for delay must be submitted to the Contractor within the time and in the manner in which the Contractor must submit such claims to the Owner, and that failure to comply with the conditions for giving notice and submitting claims shall result in the waiver of such claims.

C. Subcontractual Relations. The Contractor shall require each Subcontractor to assume all the obligations and responsibilities which the Contractor owes the Owner pursuant to the Contract Documents, by the parties to the extent of the Work to be performed by the Subcontractor. Said obligations shall be made in writing and shall preserve and protect the rights of the Owner and Architect/Engineer, with respect to the Work to be performed by the Subcontractor, so that the subcontracting thereof will not prejudice such rights. Where appropriate, the Contractor shall require each Subcontractor to enter into similar agreements with its sub-subcontractors.

D. Insurance; Acts and Omissions. Insurance requirements for Subcontractors shall be no more stringent than those requirements imposed on the Contractor by the Owner. The Contractor shall be responsible to the Owner for the acts and omissions of its employees, agents, Subcontractors, their agents and employees, and all other persons performing any of the Work or supplying materials under a contract to the Contractor.

**4.2 Relationship and Responsibilities.** Except as specifically set forth herein with respect to direct materials acquisitions by Owner, nothing contained in the Contract Documents or in any Contract Document does or shall create any contractual relation between the Owner or Architect/Engineer and any Subcontractor. Specifically, the Contractor is not acting as an agent of the Owner with respect to any Subcontractor. The utilization of any Subcontractor shall not relieve Contractor from any liability or responsibility to Owner, or obligate Owner to the payment of any compensation to the Subcontractor or additional compensation to the Contractor.

**4.3 Payments to Subcontractors; Monthly Statements.** The Contractor shall be responsible for paying all Subcontractors from the payments made by the Owner to Contractor pursuant to Article III, subject to the following provisions:

A. Payment. The Contractor shall, no later than ten (10) days after receipt of payment from the Owner, out of the amount paid to the Contractor on account of such Subcontractor's Work, pay to each Subcontractor the amount to which the Subcontractor is entitled in accordance with the terms of the Contractor's contract with such Subcontractor. The Contractor shall, by appropriate agreement with each Subcontractor, require each Subcontractor to make payments to sub-Subcontractors in a similar manner. After receipt of payment from Owner, if the need should arise to withhold payments to Subcontractors for any reason, as solely determined by Contractor, the Contractor shall promptly restore such monies to the Owner, adjusting subsequent pay requests and Project bookkeeping as required.

B. Final Payment of Subcontractors. The final payment of retainage to Subcontractors shall not be made until the Project has been inspected by the Architect/Engineer or other person designated by the Owner for that purpose, and until both the Architect/Engineer and the Contractor have issued a written certificate that the Project has been constructed in accordance with the Project Plans and Specifications and approved Change Orders. Before issuance of final payment to any Subcontractor without any retainage, the Subcontractor shall submit satisfactory evidence that all payrolls, material bills, and other indebtedness connected with the Project have been paid or otherwise satisfied, warranty information is complete, as-built markups have been submitted, and instruction for the Owner's operating and maintenance personnel is complete. Final payment may be made to certain select Subcontractors whose Work is satisfactorily completed prior to the completion of the Project, but only upon approval of the Owner's Project Representative.

**4.4 Responsibility for Subcontractors.** As provided in Section 2.4.BB, Contractor shall be fully responsible to Owner for all acts and omissions of the Subcontractors, suppliers and other persons and organizations performing or furnishing any of the Work under a direct or indirect Contract with Contractor just as Contractor is responsible for Contractor's own acts and omissions.

**4.5 Contingent Assignment of Subcontracts.** Each subcontract agreement for a portion of the Work is assigned by the Contractor to the Owner, provided that:

- (1) assignment is effective only after termination of the Contract by the Owner for cause pursuant to Article XIV and only for those subcontract agreements that the Owner accepts by notifying the Subcontractor and Contractor in writing; and
- (2) assignment is subject to the prior rights of the surety, if any, obligated under bond relating to the Agreement.

When the Owner accepts the assignment of a subcontract agreement, the Owner assumes the Contractor's rights and obligations under the subcontract. Upon such assignment, if the Work has been suspended for more than thirty (30) days, the Subcontractor's compensation shall be equitably adjusted for increases in cost resulting from the suspension. Upon such assignment to the Owner, the Owner may further assign the subcontract to a successor contractor or other entity.

If the Owner assigns the subcontract to a successor contractor or other entity, the Owner shall nevertheless remain legally responsible for all of the successor contractor's obligations under the subcontract.

## ARTICLE V

### CHANGES IN WORK

**5.1 General.** Changes in the Work may be accomplished after execution of the Agreement, and without invalidating the Agreement, by Change Order, Work Directive Change or order for a minor change in the Work, subject to the limitations stated in this Article V and elsewhere in the Contract Documents. Changes in the Work shall be performed under applicable provisions of the Contract Documents, and the Contractor shall proceed promptly, unless otherwise provided in the Change Order, Work Directive Change or order for a minor change in the Work.

**5.2 Minor Changes in the Work.** The Owner or Architect/Engineer shall have authority to order minor changes in the Work not involving adjustment in the Contract Sum or extension of the Contract Time and not inconsistent with the intent of the Contract Documents. Such change will be effected by written order signed by the Architect/Engineer and shall be binding on the Owner and Contractor. The Contractor shall abide by and perform such minor changes. Such changes shall be effected by a Field Directive or a Work Directive Change. Documentation of changes shall be determined by the Construction Team, and displayed monthly in the Progress Reports. Because such changes shall not affect the Contract Sum to be paid to the Contractor, they shall not require a Change Order pursuant to Section 5.6.

**5.3 Emergencies.** In any emergency affecting the safety of persons or property, the Contractor shall act at its discretion to prevent threatened damage, injury, or loss. Any increase in the Contract Sum or extension of time claimed by the Contractor because of emergency Work shall be determined as provided in Section 5.6. However, whenever practicable, the Contractor shall obtain verbal concurrence of the Owner's Project Representative and Architect/Engineer where the act will or may affect the Contract Sum or Contract Time.

**5.4 Concealed Conditions.** If the Contractor encounters conditions at the site that are (1) subsurface or otherwise concealed physical conditions that differ materially from those indicated in the Contract Documents or (2) unknown physical conditions of an unusual nature, that differ materially from those ordinarily found to exist and generally recognized as inherent in construction activities of the character provided for in the Contract Documents, the Contractor shall promptly provide notice to the Owner and the Architect/Engineer before conditions are disturbed and in no event later than ten (10) days after first observance of the conditions. The Architect/Engineer will promptly investigate such conditions and, if the Architect/Engineer determines that they differ materially and cause an increase or decrease in the Contractor's cost of, or time required for, performance of any part of the Work, will recommend an equitable adjustment in the Contract Sum or Contract Time, or both. If the Architect/Engineer determines that the conditions at the site are not materially different from those indicated in the Contract Documents and that no change in the terms of the Contract is justified, the Architect/Engineer shall promptly notify the Owner and Contractor in writing, stating the reasons. If the Contractor



disputes the Architect/Engineer's determination or recommendation, the Contractor may proceed as provided in Article VIII. If the Owner disputes the Architect/Engineer's determination or recommendation, the Owner may appeal directly to the Purchasing Official and shall thereafter follow the process set forth in Section 8.5.

**5.5 Hazardous Materials.** In the event the Contractor encounters on the Project Site material reasonably believed to be hazardous, petroleum or petroleum related products, or other hazardous or toxic substances, except as provided in Section 2.4.U, the Contractor shall immediately stop Work in the area affected and report the condition to the Owner and the Architect/Engineer in writing. The Work in the affected area shall not thereafter be resumed except by Change Order or written amendment, if in fact the material or substance has not been rendered harmless. The Work in the affected area shall be resumed when the Project Site has been rendered harmless, in accordance with the final determination by the Architect/Engineer or other appropriate professional employed by Owner. The Contractor shall not be required to perform without its consent any Work relating to hazardous materials, petroleum or petroleum related products, or other hazardous or toxic substances. In the event the Contractor encounters on the Project Site materials believed in good faith to be hazardous or contaminated material, and the presence of such hazardous or contaminated material was not known and planned for at the time the Contractor submitted its Bid (or Guaranteed Maximum Price proposal), and it is necessary for the Contractor to stop Work in the area affected and delays Work for more than a seven (7) day period, adjustments to the Contract Sum and/or Contract Time shall be made in accordance with this Article V.

**5.6 Change Orders; Adjustments to Contract Sum.**

A. Change Orders Generally. The increase or decrease in the Contract Sum resulting from a change authorized pursuant to the Contract Documents shall be determined:

- (1) By mutual acceptance of a lump sum amount properly itemized and supported by sufficient substantiating data, to permit evaluation by the Architect/Engineer and Owner; or
- (2) By unit prices stated in the Agreement or subsequently agreed upon; or
- (3) By any other method mutually agreeable to Owner and Contractor; or
- (4) In accordance with applicable Florida law.

If Owner and Contractor are unable to agree upon increases or decreases in the Contract Sum and the Architect/Engineer certifies that the work needs to be commenced prior to any such agreement, the Contractor, provided it receives a written Change Order signed by or on behalf of the Owner, shall promptly proceed with the Work involved. The cost of such Work shall then be determined on the basis of the reasonable expenditures of those performing the Work attributed to the change. However, in the event a Change Order is issued under these conditions, the Owner, through the Architect/Engineer, will establish an estimated cost of the Work and the Contractor shall not perform any Work whose cost exceeds that estimated without prior written approval by the Owner. In such case, the Contractor shall keep and present in such form as the Owner may prescribe an itemized accounting, together with appropriate supporting data of the increase in overall costs of the Project. The amount of any decrease in the Contract Sum to be allowed by the Contractor to

the Owner for any deletion or change which results in a net decrease in costs will be the amount of the actual net decrease.

**5.7 Owner-Initiated Changes.** Without invalidating the Agreement and without notice to any Surety, Owner may, at any time, order additions, deletions or revisions in the Work. These will be authorized by a written amendment, a Field Directive, a Change Order, or a Work Directive Change, as the case may be. Upon receipt of any such document, Contractor shall promptly proceed with the Work involved which will be performed under the applicable conditions of the Contract Documents (except as otherwise specifically provided). A Work Directive Change may not change the Contract Sum or the Contract Time; but is evidence that the parties expect that the change directed or documented by a Work Directive Change will be incorporated in a subsequently issued Change Order following negotiations by the parties as to its effect, if any, on the Contract Sum or Contract Time.

**5.8 Unauthorized Work.** Contractor shall not be entitled to an increase in the Contract Sum or an extension of the Contract Time with respect to any Work performed that is not required by the Contract Documents.

**5.9 Defective Work.** Owner and Contractor shall execute appropriate Change Orders (or written amendments) covering changes in the Work which are ordered by Owner, or which may be required because of acceptance of defective Work, without adjustment to the Contract Sum.

**5.10 Estimates for Changes.** At any time Architect/Engineer may request a quotation from Contractor for a proposed change in the Work. Within twenty-one (21) calendar days after receipt, Contractor shall submit a written and detailed proposal for an increase or decrease in the Contract Sum or Contract Time for the proposed change. If the Architect/Engineer is an Owner employee, they shall have thirty-five (35) calendar days after receipt of the price quote for a change order to respond in writing. If the Architect/Engineer is not an Owner employee, they shall have twenty-one (21) calendar days after receipt of the detailed proposal to respond in writing. The proposal shall include an itemized estimate of all costs and time for performance that will result directly or indirectly from the proposed change. Unless otherwise directed, itemized estimates shall be in sufficient detail to reasonably permit an analysis by Architect/Engineer of all material, labor, equipment, subcontracts, overhead costs and fees, and shall cover all Work involved in the change, whether such Work was deleted, added, changed or impacted. Any denial notice from the Owner's Architect/Engineer employee must specify the alleged deficiencies in the price quote and the actions necessary to remedy those deficiencies. Notwithstanding the request for quotation, Contractor shall carry on the Work and maintain the progress schedule. Delays in the submittal of the written and detailed proposal will be considered non-prejudicial.

**5.11 Form of Proposed Changes.** The form of all submittals, notices, Change Orders and other documents permitted or required to be used or transmitted under the Contract Documents shall be determined by the Owner. Standard Owner forms shall be utilized.

**5.12 Changes to Contract Time.** The Contract Time may only be changed pursuant to a Change Order or a written amendment to the Contract Documents. Any claim for an extension or shortening of the Contract Time shall be based on written notice delivered by the party making the claim to the other party. Notice of the extent of the claim with supporting data shall be delivered within fifteen (15) days from detection or beginning of such occurrence and shall be

accompanied by the claimant's written statement that the adjustment claimed is the entire adjustment to which the claimant has reason to believe it is entitled to because of the occurrence of said event. The Contract time will be extended in an amount equal to time lost due to delays beyond the control of Contractor. Such delays shall include, but not be limited to, acts or neglect by Owner or others performing additional Work; or to fires, floods, epidemics, abnormal weather conditions or acts of God. Failure to deliver a written notice of claim within the requisite 15-day period shall constitute a waiver of the right to pursue said claim.

**5.13** Notwithstanding any other provisions of the Contract Documents to the contrary, Owner shall have the right to bring a direct action in the Circuit Court to recover such costs.

## ARTICLE VI

### ROLE OF ARCHITECT/ENGINEER

#### 6.1 General.

A. Retaining. The Owner shall retain an Architect/Engineer (whether an individual or an entity) lawfully licensed to practice in Florida. That person or entity is identified as the Architect/Engineer in the Agreement and is referred to throughout the Contract Documents as if singular in number.

B. Duties. Duties, responsibilities and limitations of authority of the Architect/Engineer as set forth in the Contract Documents shall not be restricted, modified or extended without written consent of the Owner and Architect/Engineer. Consent shall not be unreasonably withheld.

C. Termination. If the employment of the Architect/Engineer is terminated, the Owner shall employ a successor Architect/Engineer as to whom the Contractor has no reasonable objection and whose status under the Contract Documents shall be that of the Architect/Engineer.

**6.2 Administration.** The Architect/Engineer will provide administration of the Agreement as described in the Contract Documents and will be an Owner's representative during construction until the date the Architect/Engineer approves the final Application for Payment. The Architect/Engineer will have authority to act on behalf of the Owner only to the extent provided in the Contract Documents.

A. Site Visits. The Architect/Engineer will visit the site at intervals appropriate to the stage of construction, or as otherwise agreed with the Owner, to become generally familiar with the progress and quality of the portion of the Work complete, and to determine in general if the Work observed is being performed in a manner indicating that the Work, when fully completed, will be in accordance with the Contract Documents. Unless specifically instructed by Owner, the Architect/Engineer will not be required to make exhaustive or continuous on-site inspections to check the quality or quantity of the Work. The Architect/Engineer will not have control over, charge of, or responsibility for, the construction means, methods, techniques, sequences or

procedures, or for the safety precautions and programs in connection with the Work, since these are solely the Contractor's rights and responsibilities under the Contract Documents.

B. **Reporting.** Based on the site visits, the Architect/Engineer will keep the Owner reasonably informed about the progress and quality of the portion of the Work completed, and report to the Owner (1) known deviations from the Contract Documents and from the most recent construction schedule submitted by the Contractor, and (2) defects and deficiencies observed in the Work. The Architect/Engineer will not be responsible for the Contractor's failure to perform the Work in accordance with the requirements of the Contract Documents. The Architect/Engineer will not have control over or charge of and will not be responsible for acts or omissions of the Contractor, Subcontractors, or their agents or employees, or any other persons or entities performing portions of the Work.

**6.3 Interpretation of Project Plans and Specifications.** The Architect/Engineer will be the interpreter of the requirements of the Project Plans and Specifications. Upon receipt of comments or objections by Contractor or Owner, the Architect/Engineer will make decisions on all claims, disputes, or other matters pertaining to the interpretation of the Project Plans and Specifications.

**6.4 Rejection of Non-Conforming Work.** Upon consultation with Owner, the Architect/Engineer shall have the authority to reject Work which does not conform to the Project Plans and Specifications.

**6.5 Correction of Work.** The Contractor shall promptly correct all Work rejected by the Architect/Engineer for being defective or as failing to conform to the Project Plans and Specifications, whether observed before or after the Substantial Completion Date and whether or not fabricated, installed, or completed. The Contractor shall bear all costs of correcting such rejected Work, including compensation for Architect/Engineer's additional services made necessary thereby.

**6.6 Timely Performance of Architect/Engineer.** The Contractor shall identify which requests for information or response from the Architect/Engineer have the greatest urgency and those items which require prioritizing in response by the Architect/Engineer. The Contractor shall also identify the preferred time period for response and shall request a response time which is reasonably and demonstrably related to the needs of the Project and Contractor. If Architect/Engineer claims that Contractor's expectations for a response are unreasonable, Owner shall require Architect/Engineer to communicate such claim to Contractor in writing together with the specific time necessary to respond and the date upon which such response will be made. If Contractor believes that Architect/Engineer is not providing timely services or responses, Contractor shall notify Owner of same in writing not less than two (2) weeks before Contractor believes performance or response time from Architect/Engineer is required without risk of delaying the Project.

## ARTICLE VII

### OWNER'S RIGHTS AND RESPONSIBILITIES

**7.1 Project Site; Title.** The Owner shall provide the lands upon which the Work under the Contract Documents is to be done, except that the Contractor shall provide all necessary additional land required for the erection of temporary construction facilities and storage of his materials, together with right of access to same. The Owner hereby represents to the Contractor that it currently has and will maintain up through and including the Substantial Completion Date, good title to all of the real property constituting the Project Site. Owner agrees to resolve, at its expense, any disputes relating to the ownership and use of the Project Site which might arise during construction.

**7.2 Project Plans and Specifications; Architect/Engineer.** The parties hereto acknowledge and agree that Owner has previously entered into an agreement with Architect/Engineer. Pursuant to the terms of such agreement, the Architect/Engineer, as an agent and representative of Owner, is responsible for the preparation of Project Plans and Specifications which consist of drawings, specifications, and other documents setting forth in detail the requirements for the construction of the Project. All such Project Plans and Specifications shall be provided either by Owner or the Architect/Engineer, and Contractor shall be under no obligation to provide same and shall be entitled to rely upon the accuracy and completeness of the Project Plans and Specifications provided by the Architect/Engineer and all preliminary drawings prepared in connection therewith. The Contractor will be furnished a reproducible set of all drawings and specifications reasonably necessary for the performance of Contractor's services hereunder and otherwise ready for printing. The Contractor shall be notified of any written modification in the agreement between Owner and Architect/Engineer.

**7.3 Surveys; Soil Tests and Other Project Site Information.** Owner shall be responsible for providing a legal description and certified land survey of the Project Site in a form and content and with such specificity as may be required by the Architect/Engineer and Contractor to perform their services. To the extent deemed necessary by Owner and Architect/Engineer, and solely at Owner's expense, Owner may engage the services of a geotechnical consultant to perform test borings and other underground soils testing as may be deemed necessary by the Architect/Engineer or the Contractor. Contractor shall not be obligated to provide such surveys or soil tests and shall be entitled to rely upon the accuracy and completeness of the information provided; subject, however, to the provisions of Section 2.4.S hereof. Owner shall provide Contractor, as soon as reasonably possible following the execution of the Contract Documents, all surveys or other survey information in its possession describing the physical characteristics of the Project Site, together with soils reports, subsurface investigations, utility locations, deed restrictions, easements, and legal descriptions then in its possession or control. Upon receipt of all surveys, soils tests, and other Project Site information, Contractor shall promptly advise Owner of any inadequacies in such information and of the need for any additional surveys, soils or subsoil tests. In performing this Work, Contractor shall use the standard of care of experienced contractors and will use its best efforts timely to identify all problems or omissions. Owner shall not be responsible for any delay or damages to the Contractor for any visible or disclosed site conditions or disclosed deficiencies in the Project Site which should have been identified by Contractor and corrected by Owner prior to the execution of the Contract Documents.

**7.4 Information; Communication; Coordination.** The Owner's Project Representative shall examine any documents or requests for information submitted by the Contractor and shall advise Contractor of Owner's decisions pertaining thereto within a reasonable period of time to avoid unreasonable delay in the progress of the Contractor's services. Contractor shall indicate if any such documents or requests warrant priority consideration. However, decisions

pertaining to approval of the Project Schedule as it relates to the date of Substantial Completion, the Project Cost, Contractor's compensation, approving or changing the Contract Sum shall only be effective when approved by Owner in the form of a written Change Order or amendment to the Contract Documents. Owner reserves the right to designate a different Owner's Project Representative provided Contractor is notified in writing of any such change. Owner and Architect/Engineer may communicate with Subcontractors, materialmen, laborers, or suppliers engaged to perform services on the Project, but only for informational purposes. Neither the Owner nor the Architect/Engineer shall attempt to direct the Work of or otherwise interfere with any Subcontractor, materialman, laborer, or supplier, or otherwise interfere with the Work of the Contractor. Owner shall furnish the data required of Owner under the Contract Documents promptly.

**7.5 Governmental Body.** The Contractor recognizes that the Owner is a governmental body with certain procedural requirements to be satisfied. The Contractor has and will make reasonable allowance in its performance of services for such additional time as may be required for approvals and decisions by the Owner and any other necessary government agency.

**7.6 Pre-Completion Acceptance.** The Owner shall have the right to take possession of and use any completed portions of the Work, although the time for completing the entire Work or such portions may not have expired, but such taking possession and use shall not be deemed an acceptance of any Work not completed in accordance with the Contract Documents.

**7.7 Ownership and Use of Drawings, Specifications and Other Instruments of Service.**

- (1) The Architect/Engineer and the Architect/Engineer's consultants shall be deemed the authors and owners of their respective instruments of service, including the Project Plans and Specifications, and will retain all common law, statutory and other reserved rights, including copyrights. The Contractor, Subcontractors, Sub-subcontractors, and material or equipment suppliers shall not own or claim a copyright in the instruments of service. Submittal or distribution to meet official regulatory requirements or for other purposes in connection with this Project is not to be construed as publication in derogation of the Architect/Engineer's or Architect/Engineer's consultants' reserved rights.
- (2) The Contractor, Subcontractors, Sub-subcontractors and material or equipment suppliers are authorized to use and reproduce the drawings and specifications provided to them solely and exclusively for execution of the Work. All copies made under this authorization shall bear the copyright notice, if any, shown on the Project Plans and Specifications or other instruments of service. The Contractor, Subcontractors, Sub-subcontractors, and material or equipment suppliers may not use the drawings or specifications on other projects or for additions to this Project outside the scope of the Work without the specific written consent of the Owner, Architect/Engineer and the Architect/Engineer's consultants.

**7.8 Owner's Project Representative.** Owner's Project Representative is Owner's Agent, who will act as directed by and under the supervision of the Owner, and who will confer with Owner/Architect/Engineer regarding his actions. The Owner's Project Representative's dealings in matters pertaining to the on-site Work shall, in general, be only with the Owner/Architect/Engineer and Contractor and dealings with Subcontractors shall only be through or with the full knowledge of Contractor.

A. Responsibilities. Except as otherwise instructed in writing by Owner, the Owner's Project Representative will:

- (1) Attend preconstruction conferences; arrange a schedule of progress meetings and other job conferences as required in consultation with Owner/Architect/Engineer and notify those expected to attend in advance; and attend meetings and maintain and circulate copies of minutes thereof;
- (2) Serve as Owner/Architect/Engineer's liaison with Contractor, working principally through Contractor's superintendent, to assist in understanding the intent of the Contract Documents. As requested by Owner/Architect/Engineer, assist in obtaining additional details or information when required at the job site for proper execution of the Work;
- (3) Report to Owner/Architect/Engineer whenever he believes that any Work is unsatisfactory, faulty or defective or does not conform to the Contract Documents;
- (4) Accompany visiting inspectors representing public or other agencies having jurisdiction over the project; record the outcome of these inspections and report to Owner/Architect/Engineer;
- (5) Review applications for payment with Contractor for compliance with the established procedure for their submission and forward them with recommendations to Owner/Architect/Engineer; and
- (6) Perform those duties as set forth elsewhere within the Contract Documents.

B. Limitations. Except upon written instructions of Owner, Owner's Project Representative shall not:

- (1) Authorize any deviation from the Contract Documents or approve any substitute materials or equipment;
- (2) Exceed limitations on Owner/Architect/Engineer's authority as set forth in the Contract Documents;
- (3) Undertake any of the responsibilities of Contractor, Subcontractors or Contractor's superintendent, or expedite the Work;

- (4) Advise on or issue directions relative to any aspect of the means, methods, techniques, sequences or procedures of construction unless such is specifically called for in the Contract Documents;
- (5) Advise on or issue directions as to safety precautions and programs in connection with the Work;
- (6) Authorize Owner to occupy the project in whole or in part; or
- (7) Participate in specialized field or laboratory tests.

## ARTICLE VIII

### RESOLUTION OF DISAGREEMENTS;

#### CLAIMS FOR COMPENSATION

**8.1 Owner to Decide Disputes.** The Owner shall reasonably decide all questions and disputes (with the exception of matters pertaining to the interpretation of the Project Plans and Specifications which shall be resolved by the Architect/Engineer pursuant to Section 6.3) that may arise in the execution and fulfillment of the services provided for under the Contract Documents, in accordance with the Procurement Ordinance.

**8.2 Finality.** The decision of the Owner upon all claims, questions, disputes and conflicts shall be final and conclusive, and shall be binding upon all parties to the Contract Documents, subject to judicial review as provided in Section 8.5 below.

**8.3 No Damages for Delay.** If at any time Contractor is delayed in the performance of Contractor's responsibilities under the Contract Documents as the result of a default or failure to perform in a timely manner by Owner or Owner's agents or employees, Contractor shall not be entitled to any damages except for compensation specifically authorized in Article III. Contractor's sole remedy will be a right to extend the time for performance. Nothing herein shall preclude Contractor from any available remedy against any responsible party other than Owner. Contractor shall be responsible for liquidated damages for delay if otherwise provided for in the Contract Documents.

**8.4 Permitted Claims Procedure.** Where authorized or permitted under the Contract Documents, all claims for additional compensation by Contractor, extensions of time affecting the Substantial Completion Date, for payment by the Owner of costs, damages or losses due to casualty, Force Majeure, Project Site conditions or otherwise, shall be governed by the following:

- (1) All claims must be submitted as a request for Change Order in the manner as provided in Article V.
- (2) The Contractor must submit a notice of claim to Owner's Project Representative and to the Architect/Engineer within fifteen (15) days of the



beginning of such occurrence. Failure to submit a claim within the requisite 15-day period shall constitute a waiver of the right to pursue said claim.

- (3) Within twenty (20) days of submitting its notice of claim, the Contractor shall submit to the Owner's Project Representative its request for Change Order, which shall include a written statement of all details of the claim, including a description of the Work affected.
- (4) After receipt of a request for Change Order, the Owner's Project Representative, in consultation with the Architect/Engineer, shall deliver to the Contractor, within thirty-five (35) days after receipt of request, its written response to the claim. If the Architect/Engineer is not an Owner employee, they shall deliver to the Contractor within twenty-one (21) days after receipt of request, its written response to the claim. Any denial notice from the Owner's Architect/Engineer employee must specify the alleged deficiencies in the price quote and the actions necessary to remedy those deficiencies.
- (5) In the event the Owner and Contractor are unable to agree on the terms of a Change Order, the Owner shall have the option to instruct the Contractor to proceed with the Work. In that event, the Owner shall pay for those parts of the Work, the scope and price of which are not in dispute. The balance of the disputed items in the order to proceed will be resolved after completion of the Work, based upon completed actual cost.
- (6) The rendering of a decision by Owner with respect to any such claim, dispute or other matter (except any which have been waived by the making or acceptance of final payment) will be a condition precedent to any exercise by Owner or Contractor of such right or remedies as either may otherwise have under the Contract Documents or by laws or regulations in respect of any such claim, dispute or other matter.

**8.5 Contract Claims and Disputes.** After completion of the process set forth in Section 8.4 above, any unresolved dispute under this Agreement shall be decided by the Purchasing Official in accordance with Section 2-26-63 of the Manatee County Code of Laws, subject to an administrative hearing process as provided in Section 2-26-64. The decision of the hearing officer in accordance with Section 2-26-64 of the Manatee County Code of Laws shall be the final and conclusive decision subject to exclusive judicial review in circuit court by a petition for certiorari.

**8.6 Claims for Consequential Damages.** The Contractor and Owner waive claims against each other for consequential damages arising out of or relating to this Agreement. This mutual waiver includes:

- (1) damages incurred by the Owner for rental expenses, for losses of use, income, profit, financing, business and reputation, and for loss of management or employee productivity or of the services of such persons, unless any of such damages or losses are covered by insurance placed by the Contractor; and

- (2) damages incurred by the Contractor for principal office expenses including the compensation of personnel stationed there, for losses of financing, business and reputation, and for loss of profit except anticipated profit arising directly from the Work.

This mutual waiver is applicable, without limitation, to all consequential damages due to either party's termination in accordance with Article XIV. Nothing contained in this Section 8.6 shall be deemed to preclude assessment of liquidated direct damages, when applicable, in accordance with the requirements of the Contract Documents.

## ARTICLE IX

### INDEMNITY

#### 9.1 Indemnity.

A. Indemnification Generally. To the fullest extent permitted by law, the Contractor shall indemnify and hold harmless the Owner, Architect/Engineer, Architect/Engineer's consultants, and agents and employees of any of them from and against claims, damages, losses and expenses, including but not limited to attorney's fees, arising out of or resulting from performance of the Work, provided that such claim, damage, loss or expense is attributable to bodily injury, sickness, disease or death, or to injury to or destruction of tangible property, but only to the extent caused by the negligent acts or omissions of the Contractor, a Subcontractor or anyone directly or indirectly employed by them or anyone for whose acts they may be liable, regardless of whether such claim, damage, loss or expense is caused in part by a party indemnified hereunder. Such obligation shall not be construed to negate, abridge, or reduce other rights or obligations of indemnity which would otherwise exist as to a party or person described in this Section 9.1.

B. Indemnification; Enforcement Actions. The Contractor's duty to indemnify and hold harmless the Owner in Section 9.1 above shall extend to fines, penalties and costs incurred by the Owner as related to any enforcement action taken by local, state, regional or federal regulatory entities. The Owner may deduct any of such fines, penalties and costs as described in this Section from any unpaid amounts then or thereafter due the Contractor under the Contract Documents. Any of such fines, penalties and costs not so deducted from any unpaid amounts due the Contractor shall be payable to the Owner at the demand of the Owner, together with interest from the date of the demand at the maximum allowable rate.

C. Claims by Employees. In claims against any person or entity indemnified under this Section 9.1 by an employee of the Contractor, a Subcontractor, anyone directly or indirectly employed by them or anyone for whose acts they may be liable, the indemnification obligation under Section 9.1.A. shall not be limited by a limitation on amount or type of damages, compensation or benefits payable by or for the Contractor or a Subcontractor under workers' compensation acts, disability benefit acts or other employee benefit acts.

**9.2 Duty to Defend.** The Contractor shall defend the Owner in any action, lawsuit, mediation or arbitration arising from the alleged negligence, recklessness or intentionally wrongful conduct of the Contractor and other persons employed or utilized by the Contractor in the performance of the Work. Notwithstanding any other provisions within this Article IX, so long as Contractor, through its own counsel, performs its obligation to defend the Owner pursuant to this Section, Contractor shall not be required to pay the Owner's costs associated with the Owner's participation in the defense.

## ARTICLE X

### ACCOUNTING RECORDS; OWNERSHIP OF DOCUMENTS

**10.1 Accounting Records.** Records of expenses pertaining to all services performed shall be kept in accordance with generally accepted accounting principles and procedures.

**10.2 Inspection and Audit.** The Contractor's records shall be open to inspection and subject to examination, audit, and/or reproduction during normal working hours by the Owner's agent or authorized representative to the extent necessary to adequately permit evaluation and verification of any invoices, payments or claims submitted by the Contractor or any of its payees during the performance of the Work. These records shall include, but not be limited to, accounting records, written policies and procedures, Subcontractor files (including proposals of successful and unsuccessful bidders), original estimates, estimating worksheets, correspondence, Change Order files (including documentation covering negotiated settlements), and any other supporting evidence necessary to substantiate charges related to the Contract Documents. They shall also include, but not be limited to, those records necessary to evaluate and verify direct and indirect costs (including overhead allocations) as they may apply to costs associated with the Contract Documents. For such audits, inspections, examinations and evaluations, the Owner's agent or authorized representative shall have access to said records from the effective date of the Contract Documents, for the duration of Work, and until three (3) years after the date of final payment by the Owner to the Contractor pursuant to the Contract Documents.

**10.3 Access.** The Owner's agent or authorized representative shall have access to the Contractor's facilities and all necessary records to conduct audits in compliance with this Article. The Owner's agent or authorized representative shall give the Contractor reasonable advance notice of intended inspections, examinations, and/or audits.

**10.4 Ownership of Documents.** Upon obtainment of Substantial Completion or termination of the Agreement, all records, documents, tracings, plans, specifications, maps, evaluations, reports, transcripts and other technical data, other than working papers, prepared or developed by the Contractor shall be delivered to and become the property of the Owner. The Contractor at its own expense may retain copies for its files and internal use.

## ARTICLE XI

### PUBLIC CONTRACT LAWS

#### 11.1 Equal Opportunity Employment.

A. Employment. The Contractor shall not discriminate against any employee or applicant for employment because of race, creed, sex, color, national origin, disability or age, and will take affirmative action to ensure that all employees and applicants are afforded equal employment opportunities without discrimination because of race, creed, sex, color, national origin, disability or age. Such action will be taken with reference to, but shall not be limited to, recruitment, employment, job assignment, promotion, upgrading, demotion, transfer, layoff or termination, rates of training or retraining, including apprenticeship and on-the-job training.

B. Participation. No person shall, on the grounds of race, creed, sex, color, national origin, disability or age, be excluded from participation in, be denied the proceeds of, or be subject to discrimination in the performance of the Agreement.

**11.2 Immigration Reform and Control Act of 1986.** Contractor acknowledges that it is responsible for complying with the provisions of the Immigration Reform and Control Act of 1986, located at 8 U.S.C. Section 1324, et seq., and regulations relating thereto. Failure to comply with the above statutory provisions shall be considered a material breach and shall be grounds for immediate termination of this Agreement.

**11.3 No Conflict of Interest.** The Contractor warrants that it has not employed or retained any company or person, other than a bona fide employee working solely for the Contractor to solicit or secure this Agreement, and that it has not paid or agreed to pay any person, company, corporation, individual, or firm other than a bona fide employee working solely for the Contractor, any fee, commission, percentage, gift or any other consideration, contingent upon or resulting from the award or making of this Agreement.

A. No Interest in Business Activity. By accepting award of this Agreement, the Contractor, which shall include its directors, officers and employees, represents that it presently has no interest in and shall acquire no interest in any business or activity which would conflict in any manner with the performance of services required hereunder, including without limitation as described in the Contractor's own professional ethical requirements. An interest in a business or activity which shall be deemed a conflict includes but is not limited to direct financial interest in any of the material and equipment manufacturers, suppliers, distributors, or contractors who will be eligible to supply material and equipment for the Project for which the Contractor is furnishing its services required hereunder.

B. No Appearance of Conflict. The Contractor shall not knowingly engage in any contractual or professional obligations that create an appearance of a conflict of interest with respect to the services provided pursuant to the Agreement. The Contractor has provided the Affidavit of No Conflict, incorporated into the Contract Documents as Exhibit "C", as a material inducement for Owner entering the Agreement. If, in the sole discretion of the County Administrator or designee, a conflict of interest is deemed to exist or arise during the term of this

Agreement, the County Administrator or designee may cancel this Agreement, effective upon the date so stated in a written notice of cancellation, without penalty to the Owner.

**11.4 Truth in Negotiations.** By execution of the Contract Documents, the Contractor certifies to truth-in-negotiations and that wage rates and other factual unit costs supporting the compensation are accurate, complete and current at the time of contracting. Further, the original Contract Sum and any additions thereto shall be adjusted to exclude any significant sums where the Owner determines the Contract Sum was increased due to inaccurate, incomplete or non-current wage rates and other factual unit costs. Such adjustments must be made within one (1) year after final payment to the Contractor.

**11.5 Public Entity Crimes.** The Contractor is directed to the Florida Public Entity Crimes Act, Section 287.133, Florida Statutes, specifically section 2(a), and the Owner's requirement that the Contractor comply with it in all respects prior to and during the term of the Agreement.

## ARTICLE XII

### FORCE MAJEURE, FIRE OR OTHER CASUALTY

#### 12.1 Force Majeure.

A. Unavoidable Delays. Delays in any performance by any party contemplated or required hereunder due to fire, flood, sinkhole, earthquake or hurricane, acts of God, unavailability of materials, equipment or fuel, war, declaration of hostilities, revolt, civil strife, altercation or commotion, strike, labor dispute, or epidemic, archaeological excavation, lack of or failure of transportation facilities, or any law, order, proclamation, regulation, or ordinance of any government or any subdivision thereof, or for any other similar cause to those enumerated, beyond the reasonable control and which with due diligence could not have been reasonably anticipated, shall be deemed to be events of Force Majeure and any such delays shall be excused. In the event such party is delayed in the performance of any Work or obligation pursuant to the Contract Documents for any of the events of Force Majeure stated in this Section 12.1, the date for performance required or contemplated by the Contract Documents shall be extended by the number of calendar days such party is actually delayed.

B. Concurrent Contractor Delays. If a delay is caused for any reason provided in Section 12.1.A. and during the same time period a delay is caused by Contractor, the date for performance shall be extended as provided in 12.1.A. but only to the extent the time is or was concurrent.

C. Notice; Mitigation. The party seeking excuse for nonperformance based on Force Majeure shall give written notice to the Owner, if with respect to the Contractor, or to the Contractor if with respect to the Owner, specifying its actual or anticipated duration. Each party seeking excuse from nonperformance based on Force Majeure shall use its best efforts to rectify any condition causing a delay and will cooperate with the other party, except that neither party shall be obligated to incur any unreasonable additional costs and expenses to overcome any loss of time that has resulted.

**12.2 Casualty; Actions by Owner and Contractor.** During the construction period, if the Project or any part thereof shall have been damaged or destroyed, in whole or in part, the Contractor shall promptly make proof of loss; and Owner and Contractor shall proceed promptly to collect, or cause to be collected, all valid claims which may have arisen against insurers or others based upon such damage or destruction. The Contractor shall diligently assess the damages or destruction and shall prepare an estimate of the cost, expenses, and other charges, including normal and ordinary compensation to the Contractor, necessary for reconstruction of the Project substantially in accordance with the Project Plans and Specifications. Within fifteen (15) days following satisfaction of the express conditions described in subsections (1), (2) and (3) below, the Contractor covenants and agrees diligently to commence reconstruction and to complete the reconstruction or repair of any loss or damage by fire or other casualty to the Project to substantially the same size, floor area, cubic content, and general appearance as prior to such loss or damage:

- (1) Receipt by the Owner or the trustee of the proceeds derived from collection of all valid claims against insurers or others based upon such damage or destruction, and receipt of other sums from any source such that the funds necessary to pay the Project Cost and any additions to the Project Cost necessitated for repair or reconstruction are available;
- (2) Written agreement executed by the Contractor and the Owner, by amendment to the Contract Documents or otherwise, authorizing and approving the repair or reconstruction and any additions to the Project Cost necessitated thereby, including any required adjustment to the Contract Sum; and
- (3) Final approval by the Owner of the Project Plans and Specifications for such repair or reconstruction and issuance of any required building permit.

**12.3 Approval of Plans and Specifications.** The Owner agrees to approve the plans and specifications for such reconstruction or repair if the reconstruction or repair contemplated by such plans and specifications is economically feasible, and will restore the Project, or the damaged portion thereof, to substantially the same condition as prior to such loss or damage, and such plans and specifications conform to the applicable laws, ordinances, codes, and regulations. The Owner agrees that all proceeds of any applicable insurance or other proceeds received by the Owner or the Contractor as a result of such loss or damage shall be used for payment of the costs, expenses, and other charges of the reconstruction or repair of the Project.

**12.4 Notice of Loss or Damage.** The Contractor shall promptly give the Owner written notice of any significant damage or destruction to the Project, defined as loss or damage which it is contemplated by Contractor will increase the Contract Sum or extend the Substantial Completion Date, stating the date on which such damage or destruction occurred, the then expectations of Contractor as to the effect of such damage or destruction on the use of the Project, and the then proposed schedule, if any, for repair or reconstruction of the Project. Loss or damage which the Contractor determines will not affect the Contract Sum or Substantial Completion Date will be reported to Owner and Architect/Engineer immediately, and associated corrective actions will be undertaken without delay.

## ARTICLE XIII

### REPRESENTATIONS, WARRANTIES AND COVENANTS

**13.1 Representations and Warranties of Contractor.** The Contractor represents and warrants to the Owner each of the following.

A. The Contractor is a construction company, organized under the laws of the State of \_\_\_\_\_, authorized to transact business in the State of Florida, with \_\_\_\_\_ as the primary qualifying agent. Contractor has all requisite power and authority to carry on its business as now conducted, to own or hold its properties, and to enter into and perform its obligations hereunder and under each instrument to which it is or will be a party, and is in good standing in the State of Florida.

B. Each Contract Document to which the Contractor is or will be a party constitutes, or when entered into will constitute, a legal, valid, and binding obligation of the Contractor enforceable against the Contractor in accordance with the terms thereof, except as such enforceability may be limited by applicable bankruptcy, insolvency, or similar laws from time to time in effect which affect creditors' rights generally and subject to usual equitable principles in the event that equitable remedies are involved.

C. There are no pending or, to the knowledge of the Contractor, threatened actions or proceedings before any court or administrative agency, within or without the State of Florida, against the Contractor or any partner, officer, or agent of the Contractor which question the validity of any document contemplated hereunder, or which are likely in any case, or in the aggregate, to materially adversely affect the consummation of the transactions contemplated hereunder, or materially adversely affect the financial condition of the Contractor.

D. The Contractor has filed or caused to be filed all federal, state, local, or foreign tax returns, if any, which were required to be filed by the Contractor, and has paid, or caused to be paid, all taxes shown to be due and payable on such returns or on any assessments levied against the Contractor.

E. Neither Contractor nor any agent or person employed or retained by Contractor has acted fraudulently or in bad faith or in violation of any statute or law in the procurement of this Agreement.

F. The Contractor shall timely fulfill or cause to be fulfilled all of the terms and conditions expressed herein which are within the control of the Contractor or which are the responsibility of the Contractor to fulfill. The Contractor shall be solely responsible for the means and methods of construction.

G. It is recognized that neither the Architect/Engineer, the Contractor, nor the Owner has control over the cost of labor, materials, or equipment, over a Subcontractor's methods of determining bid prices, or over competitive bidding, market, or negotiating conditions.

H. During the term of the Contract Documents, and the period of time that the obligations of the Contractor under the Contract Documents shall be in effect, the Contractor shall cause to occur and to continue to be in effect those instruments, documents, certificates, and events contemplated by the Contract Documents that are applicable to, and the responsibility of, the Contractor.

I. The Contractor shall assist and cooperate with the Owner and shall accomplish the construction of the Project in accordance with the Contract Documents and the Project Plans and Specifications, and will not knowingly violate any laws, ordinances, rules, regulations, or orders that are or will be applicable thereto.

J. Contractor warrants and guarantees to Owner that all Work will be in accordance with the Contract Documents and will not be defective, and that Owner, representatives of Owner, and governmental agencies with jurisdictional interests will have access to the Work at reasonable times for their observation, inspecting and testing. Contractor shall give Architect/Engineer timely notice of readiness of the Work for all required approvals and shall assume full responsibility, including costs, in obtaining required tests, inspections, and approval certifications and/or acceptance, unless otherwise stated by Owner.

K. If any Work (including Work of others) that is to be inspected, tested, or approved is covered without written concurrence of Architect/Engineer, it must, if requested by Architect/Engineer, be uncovered for observation. Such uncovering shall be at Contractor's expense unless Contractor has given Architect/Engineer timely notice of Contractor's intention to cover the same and Architect/Engineer has not acted with reasonable promptness in response to such notice. Neither observations by Architect/Engineer nor inspections, tests, or approvals by others shall relieve Contractor from Contractor's obligations to perform the Work in accordance with the Contract Documents.

L. If the Work is defective, or Contractor fails to supply sufficient skilled workers, or suitable materials or equipment, or fails to furnish or perform the Work in such a way that the completed Work will conform to the Contract Documents, Owner may order Contractor to stop the Work, or any portion thereof and terminate payments to the Contractor until the cause for such order has been eliminated. Contractor shall bear all direct, indirect and consequential costs for satisfactory reconstruction or removal and replacement with non-defective Work, including, but not limited to fees and charges of Architect/Engineers, attorneys and other professionals and any additional expenses experienced by Owner due to delays to other Contractors performing additional Work and an appropriate deductive change order shall be issued. Contractor shall further bear the responsibility for maintaining the schedule and shall not be entitled to an extension of the Contract Time or the recovery of delay damages due to correcting or removing defective Work.

M. If Contractor fails within seven (7) days after written notice to correct defective Work, or fails to perform the Work in accordance with the Contract Documents, or fails to comply with any other provision of the Contract Documents, Owner may correct and remedy any such deficiency to the extent necessary to complete corrective and remedial action. Owner may temporarily exclude Contractor from all or part of the site, temporarily take possession of all or part of the Work, Contractor's tools, construction equipment and machinery at the site or for which Owner has paid Contractor but which are stored elsewhere, all for such duration as is reasonably necessary to correct the deficiency. All direct and indirect costs of Owner in exercising



such rights and remedies will be charged against Contractor in an amount approved as to reasonableness by Architect/Engineer and a Change Order will be issued incorporating the necessary revisions.

N. If within three (3) years after the Substantial Completion Date or such longer period of time as may be prescribed by laws or regulations or by the terms of any applicable special guarantee required by the Contract Documents, any Work is found to be defective, Contractor shall promptly, without cost to Owner and in accordance with Owner's written instructions, either correct such defective Work or if it has been rejected by Owner, remove it from the site and replace it with non-defective Work. If Contractor does not promptly comply with the terms of such instruction, Owner may have the defective Work corrected/removed and all direct, indirect and consequential costs of such removal and replacement will be paid by Contractor. Failing payment by the Contractor and notwithstanding any other provisions of the Contract Documents to the contrary, Owner shall have the right to bring a direct action in the Circuit Court to recover such costs.

**13.2 Representations of the Owner.** To the extent permitted by law, the Owner represents to the Contractor that each of the following statements is presently true and accurate:

- A. The Owner is a validly existing political subdivision of the State of Florida.
- B. The Owner has all requisite corporate or governmental power and authority to carry on its business as now conducted and to perform its obligations under the Contract Documents and each Contract Document contemplated hereunder to which it is or will be a party.
- C. The Contract Documents and each Contract Document contemplated hereby to which the Owner is or will be a party has been duly authorized by all necessary action on the part of, and has been or will be duly executed and delivered by, the Owner, and neither the execution and delivery thereof nor compliance with the terms and provisions thereof or hereof: (a) requires the approval and consent of any other person or party, except such as have been duly obtained or as are specifically noted herein; (b) contravenes any existing law, judgment, governmental rule, regulation or order applicable to or binding on the Owner; or (c) contravenes or results in any breach of, default under, or result in the creation of any lien or encumbrance upon the Owner under any indenture, mortgage, deed of trust, bank loan, or credit agreement, the charter, ordinances, resolutions, or any other agreement or instrument to which the Owner is a party, specifically including any covenants of any bonds, notes, or other forms of indebtedness of the Owner outstanding on the date of the Contract Documents.
- D. The Contract Documents and each document contemplated hereby to which the Owner is or will be a party constitutes, or when entered into will constitute, a legal, valid, and binding obligation of the Owner enforceable against the Owner in accordance with the terms thereof, except as such enforceability may be limited by applicable bankruptcy, insolvency, or similar laws from time to time in effect which affect creditors' rights generally, and subject to usual equitable principles in the event that equitable remedies are involved.
- E. There are no pending or, to the knowledge of the Owner, threatened actions or proceedings before any court or administrative agency against the Owner which question the validity of the Contract Documents or any document contemplated hereunder, or which are likely

in any case or in the aggregate to materially adversely affect the consummation of the transactions contemplated hereunder or the financial or corporate condition of the Owner.

F. The Owner shall use due diligence to timely fulfill or cause to be fulfilled all of the conditions expressed in the Contract Documents which are within the control of the Owner or which are the responsibility of the Owner to fulfill.

G. During the pendency of the Work and while the obligations of the Owner under the Contract Documents shall be in effect, the Owner shall cause to occur and to continue to be in effect and take such action as may be necessary to enforce those instruments, documents, certificates and events contemplated by the Contract Documents that are applicable to and the responsibility of the Owner.

H. The Owner shall assist and cooperate with the Contractor in accomplishing the construction of the Project in accordance with the Contract Documents and the Project Plans and Specifications, and will not knowingly violate any laws, ordinances, rules, regulations, orders, contracts, or agreements that are or will be applicable thereto or, to the extent permitted by law, enact or adopt any resolution, rule, regulation, or order, or approve or enter into any contract or agreement, including issuing any bonds, notes, or other forms of indebtedness, that will result in the Contract Documents or any part thereof, or any other instrument contemplated by and material to the timely and effective performance of a party's obligations hereunder, to be in violation thereof.

## ARTICLE XIV

### TERMINATION AND SUSPENSION

**14.1 Termination for Cause by Owner.** This Agreement may be terminated by Owner upon written notice to the Contractor should Contractor fail substantially to perform a material obligation in accordance with the terms of the Contract Documents through no fault of the Owner. In the event Owner terminates for cause and it is later determined by a court of competent jurisdiction that such termination for cause was not justified, then in such event such termination for cause shall automatically be converted to a termination without cause pursuant to Section 14.2.

A. Nonperformance. If the Contractor fails to timely perform any of its obligations under the Contract Documents, including any obligation the Contractor assumes to perform Work with its own forces, or if it persistently or repeatedly refuses or fails, except in case for which extension of time is provided, to supply enough properly skilled workmen or proper materials, or fails, without being excused, to maintain an established schedule (failure to maintain schedule shall be defined as any activity that falls thirty (30) days or more behind schedule) which has been adopted by the Construction Team, or it fails to make prompt payment to Subcontractors for materials or labor, or disregards laws, rules, ordinances, regulations, or orders of any public authority having jurisdiction, or otherwise is guilty of substantial violations of the Agreement the Owner may, after seven (7) days written notice, during which period the Contractor fails to perform such obligation, make good such deficiencies and perform such actions. The Contract Sum shall be reduced by the cost to the Owner of making good such deficiencies, and the Contractor's compensation shall be reduced by an amount required to manage the making good of such deficiencies. Provided, however, nothing contained herein shall limit or preclude Owner from pursuing additional damages from Contractor because of its breach.

B. Insolvency. If the Contractor is adjudged bankrupt, or if it makes a general assignment for the benefit of its creditors, or if a receiver is appointed because its insolvency, then the Owner may, without prejudice to any other right or remedy, and after giving the Contractor and its surety, if any, fourteen (14) days written notice, and during which period the Contractor fails to cure the violation, terminate the Agreement. In such case, the Contractor shall not be entitled to receive any further payment. Owner shall be entitled to recover all costs and damages arising because of failure of Contractor to perform as provided in the Contract Documents, as well as reasonable termination expenses, and costs and damages incurred by the Owner may be deducted from any payments left owing the Contractor.

C. Illegality. Owner may terminate the Agreement if Contractor disregards laws or regulations of any public body having jurisdiction.

D. Rights of Owner. The Owner may, after giving Contractor (and the surety, if there is one) seven (7) days written notice, terminate the services of Contractor for cause; exclude Contractor from the Project Site and take possession of the Work and of all Contractor's tools, construction equipment and machinery at the Project Site and use the same to the full extent they could be used (without liability to Contractor for trespass or conversion); incorporate in the Work all materials and equipment stored at the Project Site or for which Owner has paid Contractor but which are stored elsewhere, and finish the Work as Owner may deem expedient. In such case, Contractor shall not be entitled to receive any further payment beyond an amount equal to the value of material and equipment not incorporated in the Work, but delivered and suitably stored, less the aggregate of payments previously made. If the direct and indirect costs of completing the Work exceed the unpaid balance of the Contract Sum, Contractor shall pay the difference to Owner. Such costs incurred by Owner shall be verified by Owner in writing; but in finishing the Work, Owner shall not be required to obtain the lowest quote for the Work performed. Contractor's obligations to pay the difference between such costs and such unpaid balance shall survive termination of the Agreement. In such event and notwithstanding any other provisions of the Contract Documents to the contrary, Owner shall be entitled to bring a direct action in the Circuit Court to recover such costs.

**14.2 Termination without Cause by Owner.** The Owner, through its County Administrator or designee, shall have the right to terminate the Agreement, in whole or in part, without cause upon sixty (60) calendar days' written notice to the Contractor. In the event of such termination for convenience, the Owner shall compensate Contractor for payments due through the date of termination, and one subsequent payment to cover costs of Work performed through the date of termination, subject to the terms and conditions of Section 3.1. The Contractor shall not be entitled to any other further recovery against the Owner, including, but not limited to, anticipated fees or profit on Work not required to be performed, or consequential damages or costs resulting from such termination.

A. Release of Contractor. As a condition of Owner's termination rights provided for in this subsection, Contractor shall be released and discharged from all obligations arising by, through, or under the terms of the Contract Documents, and the Payment and Performance Bond shall be released. Owner shall assume and become responsible for the reasonable value of Work performed by Subcontractors prior to termination plus reasonable direct close-out costs, but in no event shall Subcontractors be entitled to unabsorbed overhead, anticipatory profits, or damages for early termination.

B. Waiver of Protest. Contractor hereby waives any right to protest the exercise by Owner of its rights under this Section that may apply under the Procurement Ordinance.

**14.3 Suspension without Cause.** Owner may, at any time and without cause, suspend the Work or any portion thereof for a period of not more than ninety (90) days by written notice to Contractor, which will fix the date on which Work will be resumed. Contractor shall be allowed an increase in the Contract Sum or an extension of the Contract Time, or both, directly attributable to any suspension if Contractor makes an approved claim therefor.

**14.4 Termination Based Upon Abandonment, Casualty or Force Majeure.** If, after the construction commencement date (i) Contractor abandons the Project (which for purposes of this paragraph shall mean the cessation of all construction and other activities relating to the Project, excluding those which are necessary to wind down or otherwise terminate all outstanding obligations with respect to the Project, and no recommencement of same within one hundred twenty (120) days following the date of cessation), or (ii) the Project is stopped for a period of thirty (30) consecutive days due to an instance of Force Majeure or the result of a casualty resulting in a loss that cannot be corrected or restored within one hundred twenty (120) days (excluding the time required to assess the damage and complete the steps contemplated under Section 12.2), the Owner shall have the right to terminate the Agreement and pay the Contractor its compensation earned or accrued to date.

**14.5 Vacation of Project Site; Delivery of Documents.** Upon termination by Owner pursuant to Section 14.2 or 14.4, Contractor shall withdraw its employees and its equipment, if any, from the Project Site on the effective date of the termination as specified in the notice of termination (which effective date shall not be less than two (2) working days after the date of delivery of the notice), regardless of any claim the Contractor may or may not have against the Owner. Upon termination, the Contractor shall deliver to the Owner all original papers, records, documents, drawings, models and other material set forth and described in the Contract Documents.

**14.6 Termination by the Contractor.** If, through no act or fault of Contractor, the Work is suspended for a period of more than ninety (90) consecutive days by Owner or under an order of court or other public authority, or Owner fails to act on any Application for Payment or fails to pay Contractor any sum finally determined to be due; then Contractor may, upon fourteen (14) days written notice to Owner terminate the Agreement and recover from Owner payment for all Work executed, any expense sustained plus reasonable termination expenses. In lieu of terminating the Agreement, if Owner has failed to act on any Application for Payment or Owner has failed to make any payment as aforesaid, Contractor may upon fourteen (14) days written notice to Owner stop the Work until payment of all amounts then due.