

# CONSTRUCTION PLANS FOR FORCE MAIN 11 REPLACEMENT

MANATEE COUNTY, FLORIDA

OCTOBER 2017

MANATEE COUNTY PROJECT #6022489

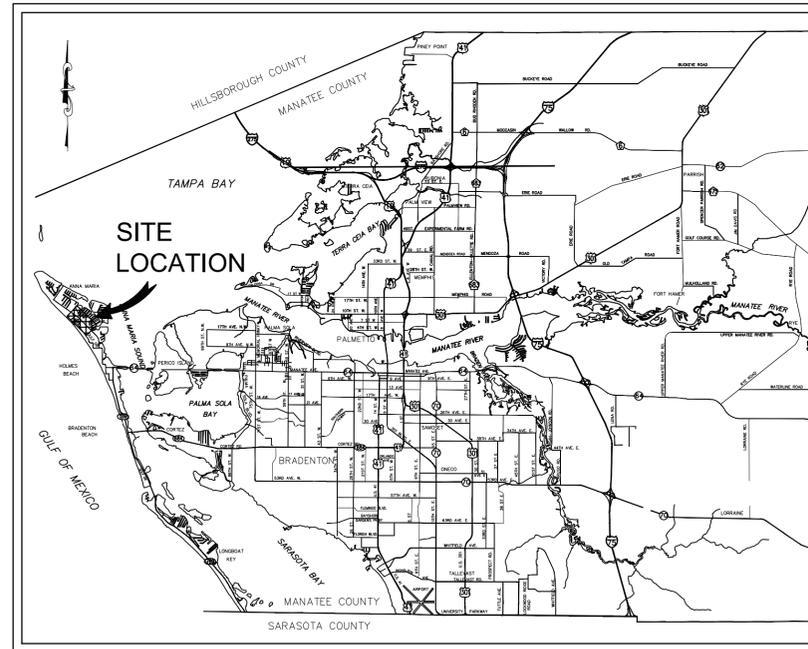

PROJECT VICINITY MAP  
N.T.S.

PROJECT TEAM:

OWNER:

MANATEE COUNTY  
1022 26TH AVE. E.  
BRADENTON, FL 34208  
CONTACT: JENNIFER FEHRS, P.E.  
941-708-7450 ext. 7236

SURVEYOR:

HYATT SURVEYING SERVICES INC.  
2012 LENA ROAD  
BRADENTON, FLORIDA 34211  
CONTACT: JOHN MATTHEWS  
941-748-4693

ENGINEER:

KIMLEY-HORN AND ASSOCIATES, INC.  
655 NORTH FRANKLIN STREET, SUITE 150  
TAMPA, FL 33602  
CONTACT: W. WADE WOOD, P.E.  
813-635-5583

GEO TECH:

ARDAMAN AND ASSOCIATES, INC.  
78 SARASOTA CENTER BOULEVARD  
SARASOTA, FLORIDA 34240  
CONTACT: JERRY H. KUEHN, P.E.  
941-922-3526

UTILITY CONTACTS:

FLORIDA POWER & LIGHT  
GREG COKER  
1253 12TH AVE. EAST  
PALMETTO, FL 34221  
941-723-4430

MANATEE COUNTY  
KATHY MCMAHON  
4520 66TH STREET W  
BRADENTON, FL 34210  
941-792-8811 EXT. 5002

FRONTIER COMMUNICATIONS  
PATTI REID  
1701 RINGLING BLVD.  
SARASOTA, FL 34236  
941-906-6711

CHARTER COMMUNICATIONS  
JIM CRUZAN  
5413 S.R. 64 EAST  
BRADENTON, FL 34208  
727-329-2846

**SHEET LIST TABLE**

SHEET NUMBER	SHEET TITLE
1	COVER SHEET
2	GENERAL NOTES
3	SURVEY NOTES AND SUE TABLES
4	KEY SHEET
5	PLAN AND PROFILE GULF DRIVE
6	PLAN AND PROFILE PALM DRIVE
7	PLAN AND PROFILE PALM DRIVE
8	PLAN AND PROFILE PALM DRIVE
9	PLAN AND PROFILE PALM DRIVE
10	PLAN AND PROFILE PALM DRIVE
11	PLAN AND PROFILE PALM DRIVE
12	PLAN AND PROFILE PALM DRIVE
13	PLAN AND PROFILE 68TH STREET
14	PLAN AND PROFILE 68TH STREET & HOLMES BOULEVARD
15	PLAN AND PROFILE HOLMES BOULEVARD
16	EXISTING LS11 PIPING
17	PROPOSED LS 11 ABOVEGROUND PIPING
18	CONSTRUCTION DETAILS
19	CONSTRUCTION DETAILS
20	CONSTRUCTION DETAILS
21	CONSTRUCTION DETAILS

PREPARED BY  
**Kimley»Horn**

© 2017 KIMLEY-HORN AND ASSOCIATES, INC.  
655 NORTH FRANKLIN STREET, SUITE 150,  
TAMPA, FL 33602  
PHONE (813) 620-1460  
WWW.KIMLEY-HORN.COM CA 00000696

No.	REVISIONS	DATE	BY

THE SITE CONSTRUCTION STAKEOUT SHALL BE PERFORMED UNDER THE DIRECTION OF A FLORIDA REGISTERED SURVEYOR. AUTOCAD FILES WILL BE FURNISHED TO AID IN THE SITE CONSTRUCTION STAKEOUT. ANY DISCREPANCIES FOUND BETWEEN AUTOCAD FILES AND SITE CONSTRUCTION PLANS SHALL BE BROUGHT TO THE ENGINEER'S ATTENTION FOR CLARIFICATION PRIOR TO THAT STAKEOUT.

THIS DOCUMENT IS PROTECTED BY SECTION 106 OF THE "UNITED STATES COPYRIGHT ACT". REPRODUCTION OR ALTERATION OF THIS DOCUMENT OR THE INFORMATION CONTAINED HEREON BY ANY MEANS WHATSOEVER IS STRICTLY PROHIBITED WITHOUT THE PRIOR WRITTEN CONSENT OF KIMLEY-HORN AND ASSOCIATES, INC. CONSENT IS HEREBY GRANTED SPECIFICALLY TO GOVERNMENTAL AGENCIES TO REPRODUCE THIS DOCUMENT IN COMPLIANCE WITH F.S. CHAPTER 119.	DATE Oct, 2017
	KHA PROJECT NO. 148400019
WADE W. WOOD, P.E. FLORIDA LICENSE NUMBER: 69051	SHEET NUMBER <b>1</b>
DATE:	

This document, together with the concepts and designs presented herein, is an instrument of service, as defined in the specific purpose and client for which it was prepared. Release of and improper reliance on this document without written authorization and signature by Kimley-Horn and Associates, Inc. shall be without liability to Kimley-Horn and Associates, Inc.

**GENERAL**

- ALL CONSTRUCTION ACTIVITIES SHALL BE COORDINATED WITH THE PROJECT MANAGEMENT DIVISION. THE PROJECT MANAGER IS: JENNIFER FEHRS, P.E. AND CAN BE REACHED AT (941) 708-7450 X7236
- IF THE CONTRACTOR WANTS A SITE VISIT PRIOR TO BIDDING, THESE SHALL BE ARRANGED THROUGH THE COUNTY'S PURCHASING DIVISION.
- ALL CONSTRUCTION ON THIS PROJECT SHALL BE IN ACCORDANCE WITH THE LATEST EDITION OF MANATEE COUNTY UTILITY AND TRANSPORTATION STANDARDS AND/OR FDOT "STANDARD SPECIFICATIONS FOR ROAD AND BRIDGE CONSTRUCTION" UNLESS OTHERWISE INDICATED ON THE PLANS.
- THE CONTRACTOR SHALL BE RESPONSIBLE FOR MEETING ALL CONDITIONS AND REQUIREMENTS OF ALL PERMITS AND ALL GOVERNING FEDERAL, STATE, AND LOCAL AGENCIES. THE CONTRACTOR SHALL OBTAIN AND PAY FOR ALL REQUIRED PERMITS THAT ARE NOT PROVIDED IN THE BID DOCUMENTS, AT NO ADDITIONAL COST TO THE OWNER.
- THE INFORMATION PROVIDED IN THESE PLANS IS SOLELY TO ASSIST THE CONTRACTOR IN ASSESSING THE NATURE AND EXTENT OF THE CONDITIONS ENCOUNTERED DURING THE COURSE OF WORK. ALL CONTRACTORS ARE DIRECTED, PRIOR TO BIDDING, TO CONDUCT WHATEVER INVESTIGATION THEY MAY DEEM NECESSARY TO ARRIVE AT THEIR OWN CONCLUSIONS REGARDING THE ACTUAL CONDITIONS THAT WILL BE ENCOUNTERED, AND UPON WHICH THEIR BIDS WILL BE BASED.
- THE CONTRACTOR SHALL REVIEW AND VERIFY ALL DIMENSIONS ON THE PLANS AND REVIEW ALL FIELD CONDITIONS THAT MAY AFFECT CONSTRUCTION. SHOULD DISCREPANCIES OCCUR, THE CONTRACTOR SHALL NOTIFY THE ENGINEER TO OBTAIN THE ENGINEER'S CLARIFICATION BEFORE COMMENCING WITH CONSTRUCTION.
- THE CONTRACTOR SHALL NOTIFY SUNSHINE 811 (1-800-432-4770) AT LEAST 2 FULL BUSINESS DAYS PRIOR TO CONSTRUCTION OPERATIONS. THE CONTRACTOR SHALL BE RESPONSIBLE FOR COORDINATING WITH ALL UTILITIES FOR THE POSSIBLE RELOCATION OR THE TEMPORARY MOVEMENT OF ANY EXISTING UTILITIES WITHIN THE RIGHTS-OF-WAY. IT IS THE CONTRACTOR'S RESPONSIBILITY TO PROTECT EXISTING UTILITIES FROM DAMAGE. EXPLORATORY EXCAVATION MAY BE REQUIRED PRIOR TO CONNECTION TO EXISTING UTILITIES.
- NO WORK, EXCEPT FOR EMERGENCY TYPE, SHALL BE PERFORMED AFTER 7:00 PM AND BEFORE 7:00 AM ON WEEKDAYS. NO WORK SHALL BE PERFORMED AFTER 5:00 PM AND BEFORE 9:00 AM ON SATURDAYS. NO WORK SHALL BE PERFORMED ON SUNDAYS. FOR ADDITIONAL PROJECT RESTRAINTS, REFER TO SECTION 01310 OF THE SPECIFICATIONS.
- THE CONTRACTOR SHALL PROVIDE CERTIFIED RECORD DRAWINGS AS OUTLINED IN THE SPECIFICATIONS. RED-LINE DRAWINGS SHALL BE CURRENT WITH EACH PAY APPLICATION SUBMITTED AND WILL BE CHECKED AS PART OF THE PAY APPLICATION REVIEW PROCESS. PAYMENT WILL NOT BE MADE TO CONTRACTOR WITHOUT APPROVED RED-LINE DRAWINGS. THE MOST CURRENT SET OF RED-LINE DRAWINGS SHALL ALSO BE BROUGHT TO EACH MONTHLY PROGRESS MEETING.
- THE CONTRACTOR SHALL INCLUDE IN HIS BID: BY-PASS PUMPING FACILITIES, PUMPS, FITTINGS, LABOR, ETC. AS NECESSARY, BASED ON METHOD AND SEQUENCE OF CONSTRUCTION TO COMPLETE ALL WORK WHILE MAINTAINING SEWER SERVICE OPERATIONS AT ALL TIMES.
- THE CONTRACTOR SHALL PROVIDE THE OWNER AND ENGINEER WITH A DETAILED CONSTRUCTION PHASING PLAN BASED ON THE CONNECTION SEQUENCING BELOW. EXISTING FORCE MAINS SHALL REMAIN IN SERVICE UNTIL ALL CONNECTIONS TO THE PROPOSED FORCE MAIN ARE CONSTRUCTED.
- ALL PROPOSED WORK SHALL BE COORDINATED WITH MANATEE COUNTY UTILITIES DEPARTMENT AT LEAST TWO WEEKS IN ADVANCE OF PROPOSED CONSTRUCTION.
- THE CONTRACTOR SHALL FURNISH SHOP DRAWINGS TO THE ENGINEER FOR REVIEW OF ALL PIPE CONNECTIONS, TRANSITIONS, AND SPECIAL APPURTENANCES PRIOR TO FABRICATION OR DELIVERY TO THE JOB SITE.
- UNLESS OTHERWISE INDICATED OR APPROVED, ALL BELOW GROUND DUCTILE IRON PIPE SHALL HAVE PUSH-ON OR MECHANICAL JOINTS, AND ALL ABOVE GROUND DUCTILE IRON PIPE SHALL HAVE FLANGED JOINTS. ALL JOINTS SHALL BE FULLY RESTRAINED PER THE DETAILS IN THESE PLANS.
- SANITARY SEWERS AND FORCEMAINS CROSSING OVER OR UNDER WATER MAINS SHALL BE LAID TO PROVIDE A MINIMUM VERTICAL DISTANCE OF 12" BETWEEN THE INVERT OF THE UPPER PIPE AND THE CROWN OF THE LOWER PIPE. WHERE THIS MINIMUM SEPARATION CANNOT BE MAINTAINED, THE CROSSING SHALL BE ARRANGED SO THAT THE SEWER OR FORCE MAIN PIPE JOINTS ARE EQUIDISTANT FROM THE POINT OF CROSSING WITH NO LESS THAN 10" BETWEEN ANY TWO JOINTS. AS AN ALTERNATIVE, THE SEWER OR FORCE MAIN MAY BE PLACED IN A WATERTIGHT CASING PIPE, CONSISTENT WITH F.A.C. RULE 62-555.314.
- ALL BELOW-GRADE FITTINGS 4-INCHES AND GREATER IN DIAMETER SHALL BE MECHANICAL JOINT DUCTILE IRON WITH PROTECTO 401 LINING FOR THEIR INTERIOR SURFACES AND COAL TAR ENAMEL COATING ON EXTERIOR SURFACES, AS NOTED IN SECTION 02615 OF SPECIFICATIONS.
- IT SHALL BE THE CONTRACTORS RESPONSIBILITY TO SECURE PROPERTY FOR STAGING MATERIALS AND EQUIPMENT.
- IT WILL BE THE CONTRACTOR'S RESPONSIBILITY TO ACQUIRE, OR ENTER INTO AGREEMENTS, FOR LANDS FOR LAY DOWN AREAS AND STAGING. THE COUNTY WILL COORDINATE AND ADVISE, TO HELP IDENTIFY POSSIBLE PARCELS. IT IS FINALLY THE CONTRACTOR'S RESPONSIBILITY TO SECURE THE NEEDED AREAS, AND THE COUNTY TAKE NO RESPONSIBILITY FOR DELAYS IN THIS REGARD.
- COORDINATION AND PUBLIC INFORMATION FOR AND WITH AREA RESIDENTS ARE OF THE UTMOST IMPORTANCE. CONTRACTOR WILL INSURE ADEQUATE NOTICE ADHERENCE TO THE COUNTY'S NOISE ORDINANCE, HAZARD AND NUISANCE ABATEMENT DIRECTIONS, PLANS, OBJECTIONS AND ORDINANCES. THE ENGINEER WILL HAVE THE FINAL DISCRETION IN THIS REGARD, AS REPRESENTED ON-SITE BY THE COUNTY INSPECTOR AND ENGINEER'S STAFF.

**SAFETY**

- THE CONTRACTOR SHALL BE RESPONSIBLE FOR COMPLIANCE WITH THE FLORIDA TRENCH SAFETY ACT, 90-96, LAWS OF FLORIDA EFFECTIVE OCTOBER 1, 1990 AND THE OCCUPATIONAL SAFETY AND HEALTH ADMINISTRATION EXCAVATION SAFETY STANDARDS, 29 CFR 1926.650, SUBPART P, AS AMENDED. THE CONTRACTOR SHALL INCLUDE IN THE TOTAL BID PRICE ALL COSTS FOR COMPLIANCE WITH THESE REGULATIONS.
- THE CONTRACTOR SHALL USE SHEET PILING, SHEETING, BRACING, ETC., AS REQUIRED IN ALL EXCAVATION AREAS AND CONFORM TO ALL OSHA REQUIREMENTS.
- THE CONTRACTOR SHALL USE ALL NECESSARY SAFETY PRECAUTIONS TO AVOID CONTACT WITH OVERHEAD AND UNDERGROUND UTILITIES, POWER LINES, ETC.
- THESE DRAWINGS DO NOT INCLUDE NECESSARY COMPONENTS FOR CONSTRUCTION SAFETY. THIS EXCLUSION DOES NOT ALLEVIATE THE CONTRACTOR FOR PROVIDING A CONTINUOUS SAFE WORKSPACE.

**ENVIRONMENTAL**

- WHEN A BENTONITE SPILL OR FRACK-OUT OCCURS OR THERE IS A LOSS OF RETURN INDICATING EXCESSIVE SEEPAGE OR LOSS OF DRILLING FLUID, DRILLING MUST BE STOPPED UNTIL THE LOCATION OF THE SPILL IS IDENTIFIED. UNDER NO CIRCUMSTANCES WILL DRILLING CONTINUE WHEN A SPILL IS APPARENT.
- ONCE LOCATED, THE BENTONITE SPILL MUST BE ISOLATED AND SEEPAGE INTO ANY NEARBY WATER BODIES WILL BE BLOCKED DEPENDING ON THE DEGREE OF THE SPILL. THE ISOLATED BENTONITE MUST BE REMOVED MANUALLY OR MECHANICALLY AND DISPOSED OF BY APPROPRIATE MEANS OR REUSED.
- THE CONTRACTOR SHALL PROVIDE AND INSTALL ALL NECESSARY STORM WATER, EROSION, AND SEDIMENTATION CONTROL MEASURES IN ACCORDANCE WITH THE FDEP "FLORIDA STORM WATER, EROSION AND SEDIMENTATION CONTROL INSPECTOR'S MANUAL". IT IS THE RESPONSIBILITY OF THE CONTRACTOR TO CONTROL AND PREVENT EROSION AND TRANSPORT OF SEDIMENT TO SURFACE DRAINS AND TO DITCHES DURING CONSTRUCTION.
- STOCKPILES SHALL BE PROTECTED AT ALL TIMES BY ON-SITE DRAINAGE CONTROLS WHICH PREVENT EROSION OF THE STOCKPILED MATERIAL. CONTROL OF DUST FROM SUCH STOCKPILES IS REQUIRED, DEPENDING UPON THEIR LOCATION AND THE EXPECTED LENGTH OF TIME THE STOCKPILES WILL BE PRESENT. IN NO CASE SHALL ANY STOCKPILED MATERIAL REMAIN AFTER THIRTY (30) CALENDAR DAYS.
- STORM WATER INLETS IN THE VICINITY OF THE PROJECT SHALL BE PROTECTED BY SEDIMENT TRAPS SUCH AS SECURED HAY BALES, SOD, STONE, ETC., WHICH SHALL BE MAINTAINED AND MODIFIED AS REQUIRED BY CONSTRUCTION PROGRESS, AND WHICH MUST BE APPROVED BY THE ENGINEER BEFORE INSTALLATION. THIS WILL BE MAINTAINED TO PREVENT DEGRADATION OF THE WATERS OF THE COUNTY AND STATE.
- SEDIMENT BASINS AND TRAPS, PERIMETER BERMS, SEDIMENT BARRIERS, VEGETATIVE BUFFERS, AND OTHER MEASURES INTENDED TO TRAP SEDIMENT AND/OR PREVENT THE TRANSPORT OF SEDIMENT ONTO ADJACENT PROPERTIES, OR INTO EXISTING BODIES OF WATER, MUST BE INSTALLED, CONSTRUCTED, OR IN THE CASE OF VEGETATIVE BUFFERS, PROTECTED FROM DISTURBANCE, AS A FIRST STEP IN THE LAND ALTERATION PROCESS. SUCH SYSTEMS SHALL BE FULLY OPERATIVE BEFORE ANY OTHER DISTURBANCE OF THE SITE BEGINS. EARTHEN STRUCTURES INCLUDING BUT NOT LIMITED TO BERMS, EARTH FILTERS, DAMS OR DIKES SHALL BE STABILIZED AND PROTECTED FROM DRAINAGE DAMAGE OR EROSION WITHIN ONE (1) WEEK OF INSTALLATION.
- ALL SWALES, DITCHES, AND CHANNELS LEADING FROM THE SITE SHALL BE PROTECTED FROM SILTATION AND EROSION DURING CONSTRUCTION AND BE SODDED WITHIN THREE (3) DAYS OF EXCAVATION.

- SOIL DISPLACED BY CONSTRUCTION WILL BE REMOVED. EROSION CONTROL SHALL BE IMPLEMENTED IN AREAS WHICH ARE CONSIDERED ENVIRONMENTALLY SENSITIVE. EROSION CONTROL SYSTEMS SHALL BE REQUIRED FOR ALL WORK WITHIN JURISDICTIONAL AREAS. THESE SYSTEMS MAY INCLUDE STAKED HAY BALES, SILT SCREENS, FILTER FABRIC, AND TURBIDITY SCREENS.
  - ALL EROSION AND POLLUTION CONTROL DEVICES SHALL BE CHECKED REGULARLY, ESPECIALLY AFTER EACH RAINFALL AND SHALL BE CLEANED OUT AND/OR REPAIRED AS REQUIRED.
  - THE CONTRACTOR SHALL NOT ENTER UPON OR IN ANY WAY ALTER WETLAND AREAS THAT MAY BE ON OR NEAR THE CONSTRUCTION SITE. ALL WORK IN THE VICINITY OF OPEN WATER AND/OR WETLANDS IS TO BE PERFORMED IN COMPLIANCE WITH THE ENVIRONMENTAL REGULATIONS AND/OR PERMITS FOR THE SITE. THE CONTRACTOR WILL BE RESPONSIBLE FOR ANY FINES RESULTING FROM HIS VIOLATION OF ANY REGULATIONS OR PERMIT CONDITIONS.
  - CONTRACTOR SHALL PROVIDE PROTECTIVE MATTING, FUEL CONTAINMENT AND ALL OTHER MATERIALS, EQUIPMENT AND LABOR TO PROTECT THE STAGING AREA DURING CONSTRUCTION.
  - CONTRACTOR SHALL, PRIOR TO BEGINNING CONSTRUCTION, SUBMIT A "FUELING SPILL PREVENTION PLAN" THAT SHALL CLEARLY INDICATE HOW FUEL SPILLS WILL BE PREVENTED WHEN FUELING BOTH WITHIN AND OUTSIDE OF THE STAGING AREA.
- RIGHT-OF-WAY**
- ALL CONSTRUCTION ACTIVITIES SHALL BE LIMITED TO WITHIN THE MANATEE COUNTY OR CITY OF HOLMES BEACH RIGHT-OF-WAY.
  - THE CONTRACTOR SHALL EMPLOY A LAND SURVEYOR REGISTERED IN THE STATE OF FLORIDA TO REFERENCE AND RESTORE PROPERTY CORNER MONUMENTS, PINS, AND LANDMARKS THAT MAY BE DISTURBED BY CONSTRUCTION AT NO ADDITIONAL COST TO THE OWNER.
  - THE CONTRACTOR, PRIOR TO CONSTRUCTION AND RESTRICTING ANY TRAFFIC, MUST OBTAIN ANY REQUIRED RIGHTS-OF-WAY USE PERMITS AND A TRAFFIC CONTROL PLAN. THE CONTRACTOR SHALL OBTAIN ALL REQUIRED PERMITS FROM OTHER GOVERNMENTAL AGENCIES HAVING RELEVANT JURISDICTION. ALL MAINTENANCE AND PROTECTION OF TRAFFIC SHALL BE IN ACCORDANCE WITH THE APPLICABLE REQUIREMENTS OF THE CURRENT FLORIDA DEPARTMENT OF TRANSPORTATION "MANUAL OF TRAFFIC CONTROL AND SAFE PRACTICES". A TRAFFIC CONTROL PLAN SHALL BE SUPPLIED BY THE CONTRACTOR AT THE PRE-CONSTRUCTION MEETING.
  - THE CONTRACTOR SHALL BE RESPONSIBLE FOR REPLACING ALL DAMAGED STORM WATER STRUCTURES, PIPING, ENTRANCE PIPE AND HEADWALLS WHETHER SHOWN ON THE PLANS OR NOT. THE HEADWALLS SHALL BE REPLACED IN ACCORDANCE WITH F.D.O.T. STANDARDS.
  - IT IS THE RESPONSIBILITY OF THE CONTRACTOR TO ESTABLISH IN THE FIELD THE RIGHT-OF-WAY LINES, BASE LINES, BENCH MARKS (ELEV.), CENTER LINES, AND STATIONING AS REQUIRED TO CONSTRUCT THIS PROJECT.
  - THE CONTRACTOR SHALL COORDINATE THE CUTTING OF DRIVEWAYS WITH THE PROPERTY OWNER PRIOR TO CUT. ALL DRIVEWAYS WILL BE IN PASSABLE CONDITION AT THE END OF THE WORK DAY AND FULLY RESTORED PER SECTION 02575.
  - A RIGHT OF ENTRY AGREEMENT SHALL BE OBTAINED BY THE CONSTRUCTION MANAGER FROM THE PROPERTY OWNER BEFORE ANY DRIVEWAY CONSTRUCTION WORK IS DONE OUTSIDE OF THE RIGHT-OF-WAY OR EASEMENT.
- UTILITIES**
- LOCATIONS, ELEVATIONS AND DIMENSIONS OF EXISTING UTILITIES, STRUCTURES AND OTHER FEATURES ARE SHOWN TO THE BEST INFORMATION AVAILABLE AT THE TIME OF PREPARATION OF THESE PLANS BUT DO NOT PURPORT TO BE ABSOLUTELY CORRECT. THERE MAY BE OTHER IMPROVEMENTS, UTILITIES, ETC. WHICH ARE WITHIN THE PROJECT AREA AND WHICH HAVE NOT BEEN IDENTIFIED, MAY NOT BE IN THE EXACT LOCATION SHOWN OR RELOCATED SINCE THE PREPARATION OF THESE PLANS. THE CONTRACTOR SHALL VERIFY, PRIOR TO CONSTRUCTION, THE LOCATIONS, ELEVATIONS AND DIMENSIONS OF ALL EXISTING UTILITIES STRUCTURES AND OTHER FEATURES (WHETHER OR NOT SHOWN ON THE PLANS) THAT MAY AFFECT HIS WORK. ALL EXISTING UTILITIES TO BE EXTENDED, CROSSED OR CONNECTION POINTS SHALL BE EXPOSED PRIOR TO CONSTRUCTION TO VERIFY LOCATION AND ELEVATION. ANY DISCREPANCIES OR CONFLICTS FOUND SHALL BE BROUGHT TO THE ENGINEER'S ATTENTION FOR RESOLUTION.
  - THE CONTRACTOR SHALL PROTECT ALL EXISTING STRUCTURES, WATER AND SEWER LINES, STORM DRAINS, UTILITIES, DRIVEWAYS, SIDEWALKS, SIGNS, MAIL BOXES, FENCES, TREES, LANDSCAPING, AND ANY OTHER IMPROVEMENT OR FACILITY IN THE CONSTRUCTION AREA. THE CONTRACTOR SHALL REPAIR AND/OR REPLACE ANY DAMAGED ITEM DUE TO HIS CONSTRUCTION ACTIVITIES TO EQUAL OR BETTER THAN PRE-CONSTRUCTION CONDITIONS AT NO ADDITIONAL COST TO THE OWNER.
  - THE CONTRACTOR SHALL USE APPROPRIATE TECHNIQUES, AS APPROVED, RECOMMENDED OR OFFERED BY FLORIDA POWER AND LIGHT TO PREVENT UNDERMINING OF POWER POLES DURING CONSTRUCTION. IF HOLDING OF POWER POLES IS RECOMMENDED OR REQUIRED BY THE UTILITY, THE CONTRACTOR SHALL COORDINATE THIS ACTIVITY WITH THE UTILITY AND BEAR ALL RELATED COSTS.
  - ANY TEMPORARY SHUTDOWNS FOR MODIFICATIONS OF EXISTING UTILITY SYSTEMS THAT MUST REMAIN IN SERVICE DURING CONSTRUCTIONS SHALL BE KEPT TO A MINIMUM AND SHALL BE COORDINATED WITH AND APPROVED BY THE MANATEE COUNTY UTILITY OPERATIONS DEPARTMENT IN ACCORDANCE WITH THE CONTRACT DOCUMENTS. IT IS NOTED THAT TEMPORARY SHUTDOWNS MAY BE RESTRICTED TO CERTAIN HOURS AT ANY TIME OF THE DAY OR NIGHT AND WILL BE COMPLETED AT NO ADDITIONAL COST TO THE OWNER.
  - FOR WORK BEING DONE ON EXISTING SANITARY SEWER LINES, THE CONTRACTOR SHALL BE RESPONSIBLE FOR MAINTAINING THE FLOW OF ALL SEWAGE DURING CONSTRUCTION, WHICH MAY REQUIRE BY-PASS PUMPING AND/OR PUMPER TRUCKS. THE CONTRACTOR SHALL SUBMIT A DETAILED BY-PASS PUMPING PLAN PER SECTION 02720.
  - THE ELEVATIONS OF THE UTILITY SERVICES AND LATERALS HAVE BEEN ASSUMED ON THE BASIS OF TYPICAL ANTICIPATED SOIL COVERAGE. CONTRACTOR SHALL NOT RELY ON THIS INFORMATION FOR CONSTRUCTION, BUT SHALL BE RESPONSIBLE FOR FIELD LOCATIONS (HORIZONTAL AND VERTICAL) OF ALL UTILITIES CROSSING THE PROPOSED FORCE MAIN. CONTRACTOR SHALL INCLUDE IN THE UNIT COST OF THE SUBJECT FORCE MAIN CONSTRUCTION, THE COST OF UTILITY ADJUSTMENTS NECESSARY TO ATTAIN DESIGN MINIMUM SEPARATION FOR UTILITIES CONFLICTING WITH THE CONSTRUCTION OF THE PROPOSED FORCE MAIN. INTERRUPTIONS OF ANY EXISTING UTILITY SERVICES SHALL BE NOTICED TO EFFECTED CUSTOMERS A MINIMUM OF 48 HOURS IN ADVANCE AND SHALL NOT EXCEED 4 HOURS IN DURATION.
- RESTORATION**
- ALL RESTORATION WORK PERFORMED THROUGHOUT THE PROJECT SHALL CONFORM TO EXISTING LINES AND GRADES UNLESS SHOWN OTHERWISE.
  - ALL DISTURBED GRASSED AREAS SHALL BE SODDED UNLESS OTHERWISE INDICATED. THE TYPE OF SOD USED TO REPLACE OWNER MAINTAINED AREAS IN RIGHT-OF-WAY SHALL BE COORDINATED WITH THE PROPERTY OWNER.
  - ALL CONCRETE THRUST BLOCKS INSTALLED FOR TESTING PURPOSES AND NOT REQUIRED FOR THE OPERATION OF THE PIPELINE SHALL BE REMOVED AND DISPOSED OF BY THE CONTRACTOR, PRIOR TO FINAL ACCEPTANCE, AT NO ADDITIONAL COST TO THE OWNER.
  - ALL DRIVEWAYS UNLESS OTHERWISE INDICATED SHALL BE RESTORED PER FORCE MAIN 11 DRIVEWAY RESTORATION DETAIL ON SHEET 20.
  - CONCRETE DRIVEWAYS OR SIDEWALKS THAT ARE CUT SHALL BE RESTORED TO MATCH EXISTING ACCORDING TO THE CURRENT EDITIONS OF THE F.D.O.T. SPECIFICATIONS FOR ROAD AND BRIDGE DESIGN, SECTION 522, AND SECTION 310 OF THE F.D.O.T. DESIGN STANDARDS UNLESS SHOWN OTHERWISE.
  - WHENEVER A PERMANENT ROADWAY SURFACE IS NOT REPLACED IMMEDIATELY AFTER BACKFILLING AND COMPACTION OF THE NEWLY INSTALLED PIPE LINE IN AREAS WHERE TRAFFIC MUST PASS, THE CONTRACTOR SHALL INSTALL A TEMPORARY SURFACE CONSISTING OF NINE INCHES OF COMPACTED LIME ROCK BASE AND A COAT OF ASPHALT EMULSION. PERMANENT ROADWAY REPAIR SHALL BE PERFORMED A MAXIMUM OF TWENTY-ONE CALENDAR DAYS AFTER THE INITIAL OPEN CUTTING.
  - RESTORATION OF CURBS, DRIVEWAYS, SIDEWALKS, AND PLACEMENT OF SOD SHALL BE COMPLETED WITHIN FORTY-FIVE CALENDAR DAYS OF INITIAL DISTURBANCE, OR TWENTY-ONE CALENDAR DAYS OF SUBSTANTIAL COMPLETION, WHICHEVER OCCURS FIRST.
  - ALL EXISTING FENCES DISTURBED DURING CONSTRUCTION SHALL BE REPAIRED OR REPLACED AND REINSTALLED BY THE CONTRACTOR AT NO ADDITIONAL COST TO THE OWNER UNLESS SHOWN TO BE REMOVED ON CONSTRUCTION PLANS.
  - WHERE CONCRETE REPAIRS ARE NECESSARY AND EXPANSION OR CONTRACTION JOINTS ARE PRESENT, CONTRACTOR SHALL REMOVE AND REPLACE CONCRETE UP TO THE NEXT EXPANSION OR CONTRACTION JOINT.
- CONSTRUCTION**
- THE EXHAUST SYSTEM OF ALL GASOLINE AND DIESEL ENGINES SHALL BE EQUIPPED WITH MUFFLERS THAT MEET THE EQUIPMENT MANUFACTURER'S REQUIREMENTS FOR NOISE SUPPRESSION. THE CONTRACTOR SHALL INSTALL NOISE ABATEMENT BARRIERS POSITIONED TO BREAK LINE-OF-SITE FROM THE NOISE SOURCE TO AFFECTED RESIDENCES, AS APPROVED BY THE ENGINEER.
  - NO MATERIAL SHALL BE STOCKPILED IN ROADWAYS. ALL DIRT AND DEBRIS SHALL BE REMOVED FROM THE JOB SITE DAILY. ROADS SHALL BE SWEEP DAILY AS PART OF DAILY CLEAN UP.

- THE CONTRACTOR IS TO CONTROL ALL FUGITIVE DUST ORIGINATING ON THIS PROJECT BY WATERING OR OTHER METHODS AS REQUIRED.
- INGRESS AND EGRESS TO ALL THE PROPERTIES IN THE CONSTRUCTION AREA SHALL BE MAINTAINED AT ALL TIMES.
- PRIOR APPROVAL WILL BE REQUIRED FOR REMOVAL OR TRIMMING OF ANY TREE WITHIN THE CONSTRUCTION AREA.
- THE CONTRACTOR SHALL PROVIDE ALL DEWATERING EQUIPMENT NECESSARY TO KEEP ALL EXCAVATIONS DRY. DEWATERING IS REQUIRED TO 18" BELOW TRENCH BOTTOM.
- ALL PIPING AND FITTINGS USED ON THIS PROJECT SHALL BE AS NOTED ON THE PLANS AND IN THE CONTRACT DOCUMENT AND SHALL BE INSTALLED TO THE LINES AND GRADES SHOWN ON THE PLANS AND PROFILES.
- ALL PIPE SHALL BE COLOR CODED TO CONFORM TO MANATEE COUNTY STANDARDS.
- ALL FITTINGS FOR PRESSURE CLASS-RATED PIPE SHALL BE RESTRAINED DUCTILE IRON. RESTRAINED LENGTHS OF PIPE SHALL ADHERE TO THE REQUIREMENTS AS SHOWN ON THE DETAIL SHEETS.
- WHERE IT IS NECESSARY TO DEFLECT PIPE EITHER HORIZONTALLY OR VERTICALLY, PIPE DEFLECTION SHALL NOT EXCEED 75% OF THE MANUFACTURER'S MAXIMUM ALLOWABLE RECOMMENDED DEFLECTION.
- ALL ROCKS OR STONES LARGER THAN SIX INCH DIAMETER SHALL BE REMOVED FROM THE BACKFILL MATERIAL. BACKFILL MATERIAL PLACED WITHIN ONE FOOT OF PIPING AND APPURTENANCES SHALL NOT CONTAIN ANY STONES LARGER THAN TWO INCH DIAMETER.
- ONLY MANATEE COUNTY UTILITY OPERATIONS STAFF ARE AUTHORIZED TO OPERATE VALVES AND PUMP STATIONS ON COUNTY OWNED AND MAINTAINED UTILITY SYSTEMS.
- THE CONTRACTOR, PRIOR TO ANY TEMPORARY WATER SHUT-OFFS DURING WATER MAIN TIE-IN, ETC., SHALL NOTIFY THE AFFECTED RESIDENTS BY POSTING INFORMATIONAL SIGNS IN THE NEIGHBORHOOD AT LEAST TWO DAYS (48 HRS) PRIOR TO THE WATER SHUT-OFF. REFERENCE SECTION 01580, PARAGRAPH 1.03 OF THE SPECIFICATIONS. WHEN FEASIBLE, "DOOR HANGERS" SHALL BE DELIVERED TO AFFECTED RESIDENCES AT LEAST TWO DAYS (48 HRS) PRIOR TO WATER SHUT-OFF. FOR LARGE PROJECTS WITH HUNDREDS OF HOMES AFFECTED, THE CONTRACTOR SHALL ALSO MAKE EXTENSIVE USE OF THE MEDIA AND SHALL HAVE PRIOR CONTACT WITH HOMEOWNER'S ASSOCIATIONS AND THE RESPECTIVE CITY'S. WRITTEN NOTIFICATIONS SHALL ALSO BE FAXED TO THE TAMPA TRIBUNE, BRADENTON HERALD, AMI SUN, ISLANDER, SARASOTA HERALD TRIBUNE, WBRD RADIO, EMERGENCY COMMUNITY CENTERS, INSPECTIONS, WATER TREATMENT PLANT, WATER MANAGER, HELPLINE, CUSTOMER SERVICE, AND THE MANATEE COUNTY UTILITY OPERATIONS DEPARTMENT.
- ALL TEST POINT PIPING SHALL BE CUT LOOSE FROM THE CORPORATION STOP AND COMPLETELY REMOVED AND DISPOSED OF BY THE CONTRACTOR PRIOR TO FINAL ACCEPTANCE. A CORPORATION STOP PLUG SHALL BE INSTALLED AND THE CORPORATION STOP SHALL REMAIN IN PLACE.
- ALL EXISTING MAINS THAT ARE BEING REPLACED SHALL BE ABANDONED IN PLACE UPON ACCEPTANCE AND ACTIVATION OF THE NEW MAINS. ABANDONED MAINS SHALL BE CUT AND CAPPED. REFER TO SECTION 02064 OF THE SPECIFICATIONS FOR CUT AND CAPPING ABANDONED PIPE.
- FIELD CONDITIONS MAY NECESSITATE MINOR ALIGNMENT AND GRADE DEVIATION OF THE PROPOSED UTILITIES TO AVOID OBSTACLES, AS ORDERED BY THE ENGINEER.
- THE CONTRACTOR SHALL OBTAIN AUTHORIZATION FROM THE MANATEE COUNTY UTILITIES DEPARTMENT (MCUD) OFFICE OF INDUSTRIAL COMPLIANCE PRIOR TO DEWATERING. COMPLETION OF A CONSTRUCTION DEWATERING AUTHORIZATION TO DISCHARGE APPLICATION IS REQUIRED. FILL OUT FORM AS COMPLETELY AS POSSIBLE AS MISSING INFORMATION DELAYS THE APPROVAL PROCESS.
- THE MCUD OFFICE OF INDUSTRIAL COMPLIANCE WILL DETERMINE WHETHER A LETTER OF APPROVAL, A DISCHARGE AUTHORIZATION, OR A DISCHARGE PERMIT IS REQUIRED.
- FOR SITES SUSPECTED OF CONTAMINATED GROUNDWATER MANATEE COUNTY WILL REQUIRE AN APPLICANT TO DEMONSTRATE THAT THE DISCHARGE MEETS THE MANATEE COUNTY SEWER USE ORDINANCE.
- IF ANY RECLAIMED OR WATER MAINS INCLUDING SERVICE LINES ARE DAMAGED DURING CONSTRUCTION, THEY SHALL BE REPLACED FROM THE VALVE TO THE OTHER POINT OF CONNECTION OUTSIDE OF THE ROADWAY PER MANATEE COUNTY'S STANDARDS.

**TRAFFIC CONTROL NOTES**

- TRAFFIC SHALL BE MAINTAINED IN ACCORDANCE WITH F.D.O.T. DESIGN STANDARDS INDICES NO. 600, 603, 605, 611, 612, 613, 616, AND 660 DEPENDING ON THE OPERATION BEING PERFORMED. FOR ALL TWO-LANE WORK, TWO-WAY, WORK WITHIN TRAVEL LANE UTILIZE INDEX 603. FOR ALL TWO-LANE WORK, TWO-WAY, WORK NEAR INTERSECTION UTILIZE INDEX 605. FOR ALL MULTILANE WORK OUTSIDE SHOULDER UTILIZE INDEX NO. 611. FOR ALL MULTILANE WORK ON SHOULDER UTILIZE INDEX NO. 612. FOR ALL MULTILANE WORK WITHIN TRAVEL WAY MEDIAN OR OUTSIDE LANE UTILIZE INDEX NO. 613. FOR ALL MULTILANE WORK NEAR INTERSECTION MEDIAN OR OUTSIDE LANE UTILIZE INDEX NO. 616. FOR PEDESTRIAN CONTROL FOR CLOSURE OF SIDEWALK, UTILIZE FDOT INDEX NO. 660.
- CONTRACTOR TO COORDINATE WITH ED HERNDON (941) 708-4436 AT FDOT FOR ALL WORK DONE ON A STATE FACILITY.
- TO AVOID DISRUPTION DUE TO INCLEMENT WEATHER, THE CONTRACTOR SHOULD PERFORM ANY MILLING AND PAVING OPERATIONS DURING THE SAME WORK PERIOD.
- ALL EXISTING PAVEMENT MARKINGS OUTSIDE THE CONSTRUCTION LIMITS THAT HAVE BEEN ALTERED BECAUSE OF CONSTRUCTION OPERATIONS SHALL BE REPLACED UPON THE COMPLETION OF THE PROJECT AT THE CONTRACTORS EXPENSE.
- LANE CLOSURES SHALL OCCUR BETWEEN 9:00 P.M. AND 5:00 A.M., UNLESS LANE CLOSURE CALCULATIONS ARE PROVIDED AND APPROVED OR APPROVAL IS GRANTED BY THE DISTRICT PERMIT ENGINEER.
- THE CONTRACTOR SHALL SCHEDULE WORK OPERATIONS SO THAT ALL LANES CAN BE RE-OPENED TO TRAFFIC WITHIN A PERIOD OF 24 HOURS IN CASE OF AN EMERGENCY.
- PEDESTRIANS, BICYCLES, AND WHEELCHAIRS: AT THE END OF EACH WORKDAY OR WHENEVER THE WORK ZONE BECOMES INACTIVE, ANY DROP-OFF ADJACENT TO A SIDEWALK SHALL BE BACKFILLED AT A SLOPE NOT TO EXCEED 1:4, OR SHALL BE PROTECTED IN ACCORDANCE WITH STANDARD INDEX 600
- PEDESTRIAN AND WHEELCHAIR TRAFFIC SHALL BE ACCOMMODATED UTILIZING STANDARD INDEX 660.
- ONE PORTABLE VARIABLE MESSAGE SIGN SHALL BE USED IN ADVANCE OF EACH LANE CLOSURE. THE FOLLOWING ARE SUGGESTED MESSAGES TO USE IN THE APPROPRIATE SITUATIONS:
 

MESSAGE 1  
 "RIGHT" OR "CENTER" OR "LEFT"  
 "LANE" "LANE" "LANE"  
 "CLOSED" "CLOSED" "CLOSED"
- THE CONTRACTOR SHALL BE RESPONSIBLE FOR THE IMMEDIATE REMOVAL OF STORMWATER FROM ROADWAYS UTILIZED FOR TRAFFIC CONTROL IN A MANNER APPROVED BY THE ENGINEER.
- AT THE END OF EACH WORKING DAY'S ACTIVITY, TEMPORARY PAVEMENT MARKINGS AND TEMPORARY RPM'S SHALL BE INSTALLED PRIOR TO OPENING THE LANES UP FOR TRAFFIC.
- ALL PAVEMENT MARKINGS, SIGNS, MARKERS, CHANNELIZATION REQUIRED TO PHASE WORK OR SHIFT TRAFFIC, SHALL UTILIZE INDICES FOR PLACEMENT.
- THE CONTRACTOR SHALL RESTRICT THE OPERATIONS SO THAT THE FIRST LIFT OF ASPHALT IS PLACED ON THE SAME DAY THAT THE LANES ARE MILLED, BEFORE OPENING THE LANES TO TRAFFIC. INSTALL TEMPORARY PAVEMENT MARKINGS AFTER THE FIRST LIFT AND PRIOR TO OPENING.
- MILLING AND RESURFACING SHALL BE ACCOMPLISHED DURING THE OFF-PEAK HOURS.
- THE CONTRACTOR IS RESPONSIBLE TO RETIME THE TRAFFIC SIGNALS WITHIN THE PROJECT LIMITS (INCLUDING LIMITS OF WORK ZONE TRAFFIC CONTROL) THAT ARE DIRECTLY AFFECTED DURING VARIOUS PHASES OF CONSTRUCTION. COORDINATE ALL SIGNAL RETIME EFFORTS WITH MUKUNDA GOPALAKRISHNA, P.E., PTOE, COUNTY TRAFFIC ENGINEER, AT 941-749-3500, EXT. 7813.

**ABBREVIATIONS**

- RJ - RESTRAINED JOINT
- R/W - RIGHT-OF-WAY
- HDD - HORIZONTAL DIRECTIONAL DRILL
- RCP - REINFORCED CONCRETE PIPE
- ARV - AIR RELEASE VALVE
- HDPE - HIGH DENSITY POLYETHYLENE
- PVC - POLYVINYL CHLORIDE
- ST - STORM DRAIN
- EX - EXISTING
- BT - BURIED TELEPHONE
- SS - SANITARY SEWER
- FM - FORCE MAIN
- WM - WATER MAIN
- RW - RECLAIM WATER MAIN
- ECP - ELLIPTICAL CONCRETE PIPE

**KIMLEY HORN LEGEND**

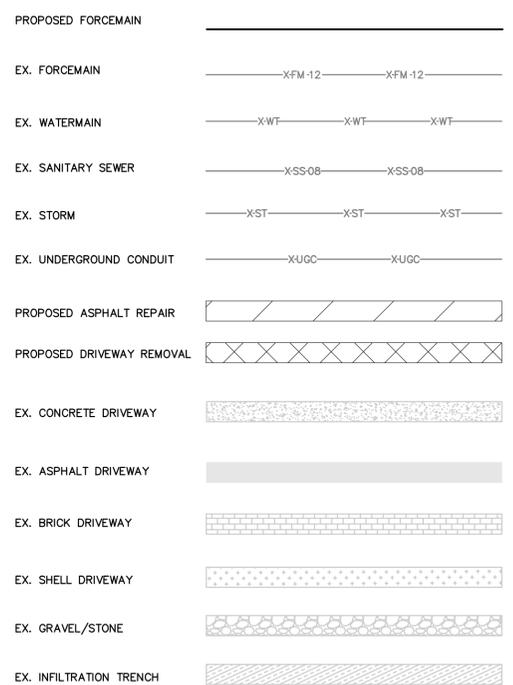

**GROUNDWATER / DEWATERING NOTE:**  
 THE PRESENCE OF GROUNDWATER SHOULD BE ANTICIPATED ON THIS PROJECT. CONTRACTOR'S BID SHALL INCLUDE CONSIDERATION FOR THIS ISSUE. WHEN PERFORMING GRADING OPERATIONS DURING PERIODS OF WET WEATHER, PROVIDE ADEQUATE DEWATERING, DRAINAGE AND GROUND WATER MANAGEMENT TO CONTROL MOISTURE OF SOILS.



No.	REVISIONS	DATE	BY

**Kimley»Horn**

© 2017 KIMLEY-HORN AND ASSOCIATES, INC.  
 655 NORTH FRANKLIN STREET, SUITE 150, TAMPA, FL 33602  
 PHONE: 813-620-1460  
 WWW.KIMLEY-HORN.COM CA 00000696

KHA PROJECT	148400019
DATE	10/24/2017
SCALE	AS SHOWN
DESIGNED BY	JWW
DRAWN BY	SAE
CHECKED BY	WWW

**Manatee County**  
 FLORIDA

**FORCE MAIN 11 REPLACEMENT**

FL MANATEE COUNTY

LICENSED PROFESSIONAL	W. WADE WOOD, P.E.
FL LICENSE NUMBER	69051

**GENERAL NOTES**

SHEET NUMBER	2
--------------	---

This document, together with the concepts and designs presented herein, is intended only for the specific purpose and client for which it was prepared. Reuse of and improper reliance on this document without written authorization and approval by Kimley-Horn and Associates, Inc. shall be without liability to Kimley-Horn and Associates, Inc.

**UTILITY LOCATION**

DESIGNATION	GRADE	DESCRIPTION	TOP UTILITY EL
VH 101	2.22'	3" CIP WM (MANCO)	0.22'
VH 102	2.13'	2" PVC WL (MANCO)	-0.17'
VH 103	2.02'	12" CIP WM (MANCO)	-0.89'
VH 104	2.45'	16" (NOT FIELD VERIFIED) CIP FM	-1.50'
VH 105	2.54'	4" PVC BURIED TELEPHONE (FRONTIER)	-0.21'
VH 106	2.56'	8" AC WM (MANCO)	-0.54'
VH 107	2.85'	4" PVC BT & 2" DIR BUR BT (FRONTIER)	0.15'
VH 108	2.45'	WM (NOT FIELD VERIFIED) (MANCO)	-3.25'
VH 109	3.20'	8" CIP WM (MANCO)	0.55'
VH 110	3.32'	4" PVC BT & 2" DIR BUR BT (FRONTIER)	1.47'
VH 111	2.72'	16" DIP WM (MANCO)	0.97'
VH 112	2.88'	1/2" LEAD BT (FRONTIER)	0.14'
VH 113	2.12'	4" PVC BT & 1 1/2" DIR BUR BT (FRONTIER)	1.15'
VH 114	1.77'	6" AC WM (MANCO)	0.92'
VH 115	2.87'	8" AC WM (MANCO)	0.27'
VH 116	2.98'	16" DIP FM (MANCO)	-0.64'
VH 117	2.95'	1 1/2" DIRECT BURIED BT (FRONTIER)	0.47'
VH 118	3.20'	16" DIP FM (MANCO)	0.10'
VH 119	3.00'	1" DIRECT BURIED BT (FRONTIER)	0.38'
VH 120	2.65'	2" DIRECT BURIED BT (FRONTIER)	0.64'
VH 121	2.69'	1" DIR BUR BT & 1/2" DIR BUR BT	0.59'
VH 122	2.82'	1" LEAD BT (2) (FRONTIER)	0.17'
VH 123	2.77'	4" LEAD SPLICE BT (FRONTIER)	0.47'
VH 124	1.95'	16" (NOT FIELD VERIFIED) STEEL FM	-2.05'

**SITE CONTROL**

DESIGNATION	NORTHING	EASTING	ELEVATION	DESCRIPTION
10	1159170.46	420375.94	3.07'	IRC (LB 7203)
11	1158918.29	420835.62	2.69'	IRC (LB 7203)
12	1158640.18	421254.44	2.87'	IRC (LB 7203)
13	1158194.16	421706.65	2.70'	IRC (LB 7203)
14	1157850.22	422124.94	2.43'	IRC (LB 7203)
15	1157439.57	422507.87	2.51'	IRC (LB 7203)
16	1157096.24	422918.16	1.74'	IRC (LB 7203)
17	1156772.00	422483.37	1.79'	ND (LB 7203)
18	1157054.23	422312.73	1.96'	ND (LB 7203)

**SURVEY NOTES**

1. THE FOLLOWING NGS VERTICAL CONTROL MONUMENT WAS RECOVERED AND UTILIZED FOR THE ELEVATIONS INDICATED HEREIN: "GIS 100" PID AG9205 NAVD 1988 ELEVATION 2.56'
2. THIS SURVEY IS REFERENCED TO A PROJECTION OF THE FLORIDA STATE PLANE COORDINATE SYSTEM (WEST ZONE NAD 1983/2011 ADJUSTMENT).
3. THIS IS NOT A BOUNDARY SURVEY. TITLE WORK WAS NOT PROVIDED.
4. THIS SURVEY IS SUBJECT TO PERTINENT EASEMENTS, RIGHTS-OF-WAY AND RESTRICTIONS OF RECORD, IF ANY.
5. THIS SURVEY DRAWING WAS PREPARED FOR THE EXCLUSIVE USE OF THE PARTY OR PARTIES CERTIFIED TO BELOW FOR THE EXPRESS PURPOSE STATED HEREON AND/OR CONTAINED IN THE CONTRACT BETWEEN HYATT SURVEY SERVICES, INC. AND THE CLIENT FOR THIS PROJECT. COPYING, DISTRIBUTING AND/OR USING THIS DRAWING, IN WHOLE OR IN PART FOR ANY PURPOSE OTHER THAN ORIGINALLY INTENDED WITHOUT WRITTEN CONSENT FROM HYATT SURVEY SERVICES, INC. IS STRICTLY PROHIBITED AND RENDERS THE SURVEYOR'S CERTIFICATION, SIGNATURE AND SEAL NULL AND VOID. ANY QUESTIONS CONCERNING THE CONTENT OR PURPOSE OF THIS DRAWING SHOULD BE DIRECTED TO HYATT SURVEY SERVICES, INC.

**SURVEY LEGEND**

IP	●	SITE CONTROL POINT	R/W	RIGHT-OF WAY
IR	○	IRON PIPE FOUND	ND	NAIL W/ DISC
	●	IRON ROD FOUND	IRC	IRON ROD W/ CAP
	■	CONCRETE MONUMENT FOUND		
	○	SUBSURFACE INVESTIGATION SIGN		PINE
	◇	WOOD UTILITY POLE		PALM
	▬	CONCRETE UTILITY POLE		
	WM	GUY WIRE		
	□	WATER METER		TREE
	⊥	WATER VALVE		
	⊙	SANITARY MANHOLE		
	⊕	FIRE HYDRANT		
	BFP	BACKFLOW PREVENTER		
	▭	UTILITY BOX		
	▭	UTILITY RISER		
	Ⓜ	ELECTRIC SERVICE BOX		
	Ⓣ	TELEPHONE SERVICE BOX		

**NOTE:**  
1. THIS INFORMATION WAS PROVIDED BY HYATT SURVEY SERVICES, INC.

**GROUNDWATER / DEWATERING NOTE:**  
THE PRESENCE OF GROUNDWATER SHOULD BE ANTICIPATED ON THIS PROJECT. CONTRACTOR'S BID SHALL INCLUDE CONSIDERATION FOR THIS ISSUE. WHEN PERFORMING GRADING OPERATIONS DURING PERIODS OF WET WEATHER, PROVIDE ADEQUATE DEWATERING, DRAINAGE AND GROUND WATER MANAGEMENT TO CONTROL MOISTURE OF SOILS.



No.	REVISIONS	DATE	BY	<p>© 2017 KIMLEY-HORN AND ASSOCIATES, INC. 655 NORTH FRANKLIN STREET, SUITE 150, TAMPA, FL 33602 PHONE: 813-620-1460 WWW.KIMLEY-HORN.COM CA 00000696</p>	<p>KHA PROJECT 148400019</p> <p>DATE 10/24/2017</p> <p>SCALE AS SHOWN</p> <p>DESIGNED BY JWW</p> <p>DRAWN BY SAE</p> <p>CHECKED BY WWW</p>	<p><b>FORCE MAIN 11 REPLACEMENT</b></p> <p>MANATEE COUNTY</p>	<p>LICENSED PROFESSIONAL</p> <p>W. WADE WOOD, P.E.</p> <p>FL LICENSE NUMBER 69051</p>	<p>FL DATE:</p>	<p><b>SURVEY NOTES AND SUE TABLES</b></p>	<p>SHEET NUMBER</p> <p><b>3</b></p>	

This document, together with the concepts and designs presented herein, is an instrument of service, as an instrument of service, as intended only for the specific purpose and client for which it was prepared. Blank or unimpressed copies of this document without written authorization and copyright by Kimley-Horn and Associates, Inc. shall be without liability to Kimley-Horn and Associates, Inc.

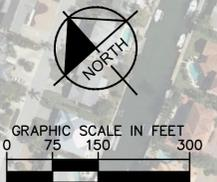

**GROUNDWATER / DEWATERING NOTE:**  
 THE PRESENCE OF GROUNDWATER SHOULD BE ANTICIPATED ON THIS PROJECT. CONTRACTOR'S BID SHALL INCLUDE CONSIDERATION FOR THIS ISSUE. WHEN PERFORMING GRADING OPERATIONS DURING PERIODS OF WET WEATHER, PROVIDE ADEQUATE DEWATERING, DRAINAGE AND GROUND WATER MANAGEMENT TO CONTROL MOISTURE OF SOILS.



No.	REVISIONS	DATE	BY

**Kimley»Horn**  
 © 2017 KIMLEY-HORN AND ASSOCIATES, INC.  
 655 NORTH FRANKLIN STREET, SUITE 150, TAMPA, FL 33602  
 PHONE: 813-620-1460  
 WWW.KIMLEY-HORN.COM CA 00000696

KHA PROJECT  
 148400019  
 DATE  
 10/24/2017  
 SCALE AS SHOWN  
 DESIGNED BY JWW  
 DRAWN BY SAE  
 CHECKED BY WWW

**Manatee County**  
**FLORIDA**  
**FORCE MAIN 11 REPLACEMENT**  
 MANATEE COUNTY  
 FL DATE:

LICENSED PROFESSIONAL  
 W. WADE WOOD, P.E.  
 FL LICENSE NUMBER  
 69051

**KEY SHEET**

SHEET NUMBER  
**4**



This document, together with the concepts and designs presented herein, is intended only for the specific purpose and client for which it was prepared. Reuse of and improper reliance on this document without written authorization and approval by Kimley-Horn and Associates, Inc. shall be without liability to Kimley-Horn and Associates, Inc.

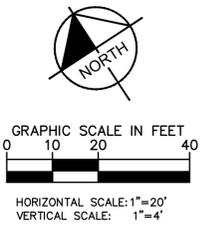
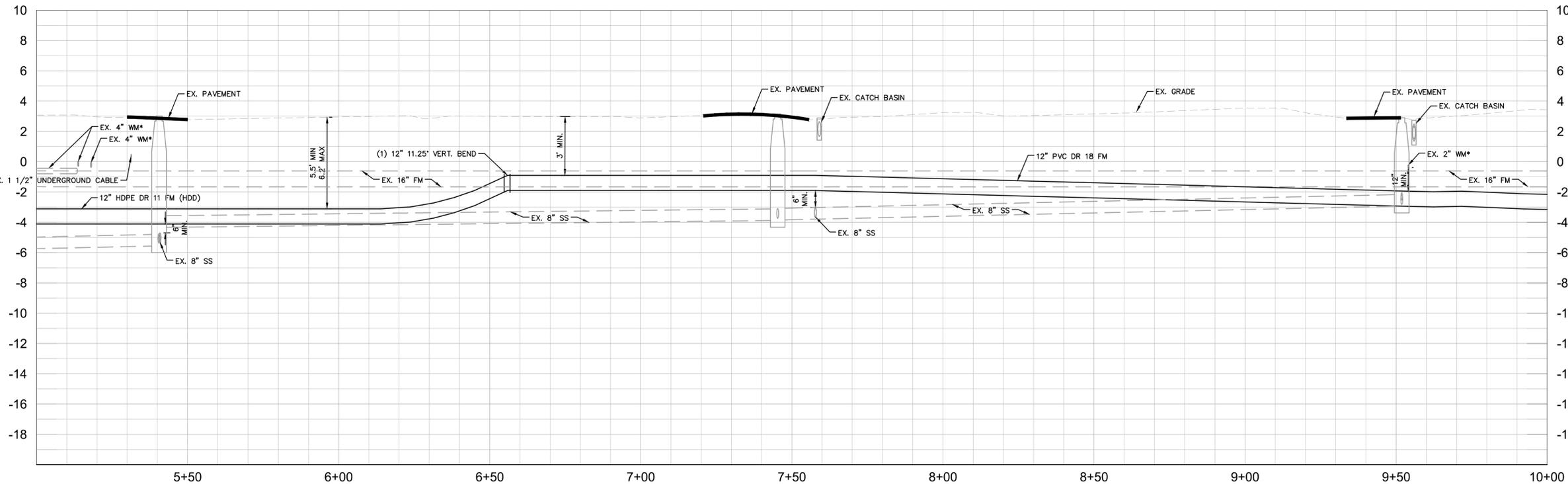
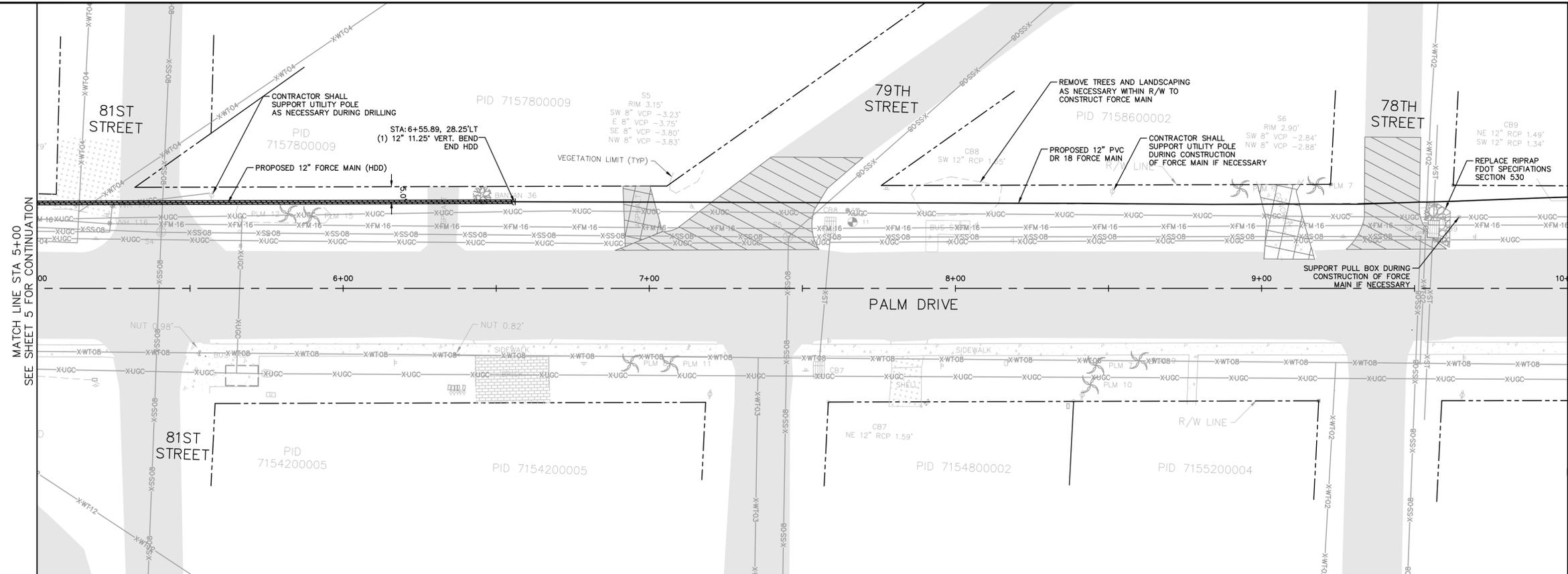

**LEGEND**

- DRIVEWAY REMOVAL
- ROADWAY RESTORATION

**NOTES:**

1. CONTRACTOR TO FOLLOW RESTRAINED LENGTHS SET IN RESTRAIN LENGTH DETAILS ON SHEET 19.
2. CONSTRUCTION DEWATERING SHALL BE CONDUCTED IN ACCORDANCE WITH ALL FEDERAL, STATE, AND LOCAL REQUIREMENTS INCLUDING BUT NOT LIMITED TO CHAPTERS 62-621.300 AND 62-620 OF THE FLORIDA ADMINISTRATIVE CODE (FAC).
3. REFER TO DETAIL UG-12 SHEET 18 FOR COUNTY ROADWAY REPAIR REQUIREMENTS SHEET 20, FOR CITY RESTORATION REQUIREMENTS.
4. REFER TO DRIVEWAY RESTORATION DETAIL SHEET 20, FOR CITY RESTORATION REQUIREMENTS.

**\*NOTES:**  
 THE ELEVATIONS OF THE UTILITIES MARKED WITH AN ASTERISK (\*) HAVE BEEN ASSUMED ON THE BASIS OF TYPICAL ANTICIPATED SOIL COVERAGE. CONTRACTOR SHALL NOT RELY ON THIS INFORMATION FOR CONSTRUCTION, BUT SHALL BE RESPONSIBLE FOR FIELD LOCATIONS (HORIZONTAL AND VERTICAL) OF ALL UTILITIES CROSSING THE PROPOSED FORCE MAIN. CONTRACTOR SHALL INCLUDE IN THE UNIT COST OF THE SUBJECT FORCE MAIN CONSTRUCTION, THE COST OF UTILITY ADJUSTMENTS NECESSARY TO ATTAIN DESIGN MINIMUM SEPARATION FOR UTILITIES CONFLICTING WITH THE CONSTRUCTION OF THE PROPOSED FORCE MAIN. INTERRUPTIONS OF ANY EXISTING UTILITY SERVICES SHALL BE NOTICED TO EFFECTED CUSTOMERS A MINIMUM OF 48 HOURS IN ADVANCE AND SHALL NOT EXCEED 4 HOURS IN DURATION.

WHERE CONCRETE REPAIRS ARE NECESSARY AND EXPANSION JOINTS ARE PRESENT, CONTRACTOR TO REMOVE AND REPLACE CONCRETE UP TO THE NEXT EXPANSION JOINT; OTHERWISE, REPLACE CONCRETE AS NECESSARY.

**GROUNDWATER / DEWATERING NOTE:**  
 THE PRESENCE OF GROUNDWATER SHOULD BE ANTICIPATED ON THIS PROJECT. CONTRACTOR'S BID SHALL INCLUDE CONSIDERATION FOR THIS ISSUE. WHEN PERFORMING GRADING OPERATIONS DURING PERIODS OF WET WEATHER, PROVIDE ADEQUATE DEWATERING, DRAINAGE AND GROUND WATER MANAGEMENT TO CONTROL MOISTURE OF SOILS.



No.	REVISIONS	DATE	BY

**Kimley & Horn**

© 2017 KIMLEY-HORN AND ASSOCIATES, INC.  
 655 NORTH FRANKLIN STREET, SUITE 150, TAMPA, FL 33602  
 PHONE: 813-620-1460  
 WWW.KIMLEY-HORN.COM CA 00000696

KHA PROJECT  
 148400019  
 DATE  
 10/24/2017  
 SCALE AS SHOWN  
 DESIGNED BY JWW  
 DRAWN BY SAE  
 CHECKED BY WWW

**Manatee County Florida**

**FORCE MAIN 11 REPLACEMENT**

MANATEE COUNTY

LICENSED PROFESSIONAL  
 W. WADE WOOD, P.E.  
 FL LICENSE NUMBER  
 69051

**PLAN AND PROFILE PALM DRIVE**

FL DATE:

SHEET NUMBER  
**6**

This document, together with the concepts and designs presented herein, is an instrument of service, intended only for the specific purpose and client for which it was prepared. Reuse of and improper reliance on this document without written authorization and adaptation by Kimley-Horn and Associates, Inc. shall be without liability to Kimley-Horn and Associates, Inc.

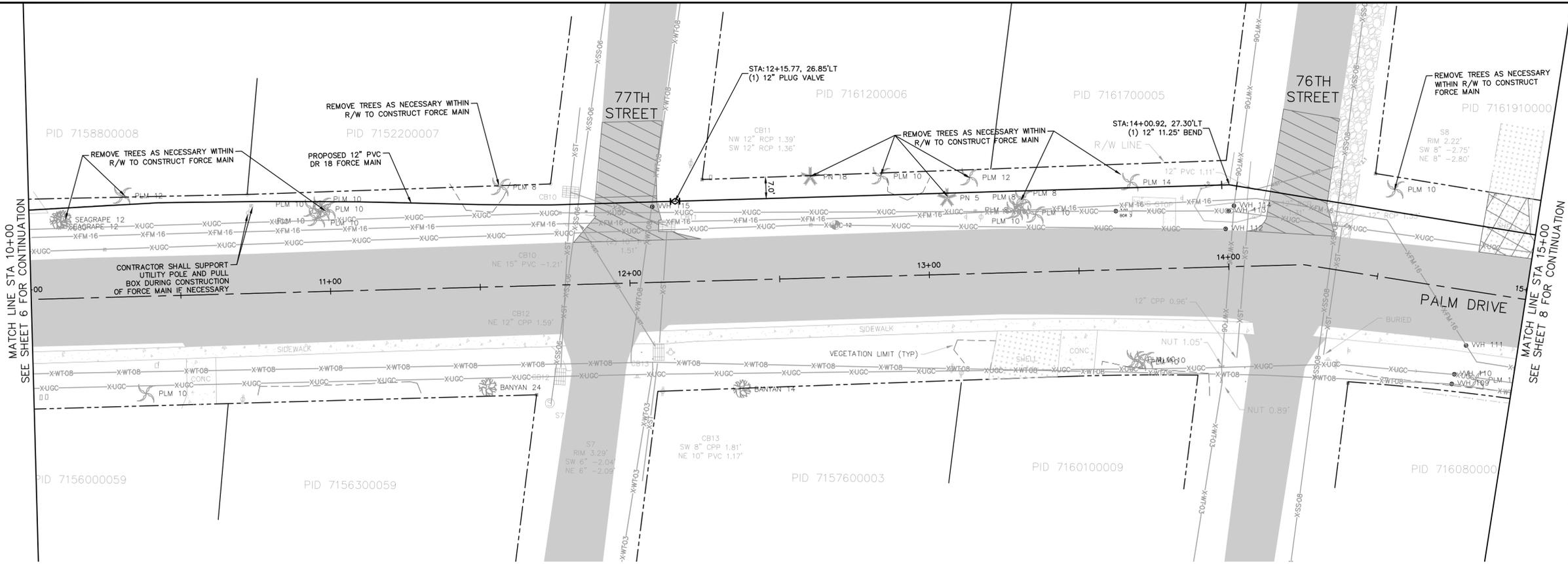
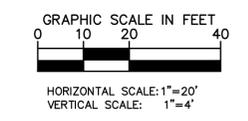

**LEGEND**

- DRIVEWAY REMOVAL
- ROADWAY RESTORATION

**NOTES:**

1. CONTRACTOR TO FOLLOW RESTRAINED LENGTHS SET IN RESTRAIN LENGTH DETAILS ON SHEET 19.
2. CONSTRUCTION DEWATERING SHALL BE CONDUCTED IN ACCORDANCE WITH ALL FEDERAL, STATE, AND LOCAL REQUIREMENTS INCLUDING BUT NOT LIMITED TO CHAPTERS 62-621.300 AND 62-620 OF THE FLORIDA ADMINISTRATIVE CODE (FAC).
3. REFER TO DETAIL UG-12 SHEET 18 FOR COUNTY ROADWAY REPAIR REQUIREMENTS.
4. REFER TO DRIVEWAY RESTORATION DETAIL SHEET 20, FOR CITY RESTORATION REQUIREMENTS.

**\*NOTES:**  
THE ELEVATIONS OF THE UTILITIES MARKED WITH AN ASTERISK (\*) HAVE BEEN ASSUMED ON THE BASIS OF TYPICAL ANTICIPATED SOIL COVERAGE. CONTRACTOR SHALL NOT RELY ON THIS INFORMATION FOR CONSTRUCTION, BUT SHALL BE RESPONSIBLE FOR FIELD LOCATIONS (HORIZONTAL AND VERTICAL) OF ALL UTILITIES CROSSING THE PROPOSED FORCE MAIN. CONTRACTOR SHALL INCLUDE IN THE UNIT COST OF THE SUBJECT FORCE MAIN CONSTRUCTION, THE COST OF UTILITY ADJUSTMENTS NECESSARY TO ATTAIN DESIGN MINIMUM SEPARATION FOR UTILITIES CONFLICTING WITH THE CONSTRUCTION OF THE PROPOSED FORCE MAIN. INTERRUPTIONS OF ANY EXISTING UTILITY SERVICES SHALL BE NOTICED TO EFFECTED CUSTOMERS A MINIMUM OF 48 HOURS IN ADVANCE AND SHALL NOT EXCEED 4 HOURS IN DURATION.

WHERE CONCRETE REPAIRS ARE NECESSARY AND EXPANSION JOINTS ARE PRESENT, CONTRACTOR TO REMOVE AND REPLACE CONCRETE UP TO THE NEXT EXPANSION JOINT; OTHERWISE, REPLACE CONCRETE AS NECESSARY.

**GROUNDWATER / DEWATERING NOTE:**  
THE PRESENCE OF GROUNDWATER SHOULD BE ANTICIPATED ON THIS PROJECT. CONTRACTOR'S BID SHALL INCLUDE CONSIDERATION FOR THIS ISSUE. WHEN PERFORMING GRADING OPERATIONS DURING PERIODS OF WET WEATHER, PROVIDE ADEQUATE DEWATERING, DRAINAGE AND GROUND WATER MANAGEMENT TO CONTROL MOISTURE OF SOILS.

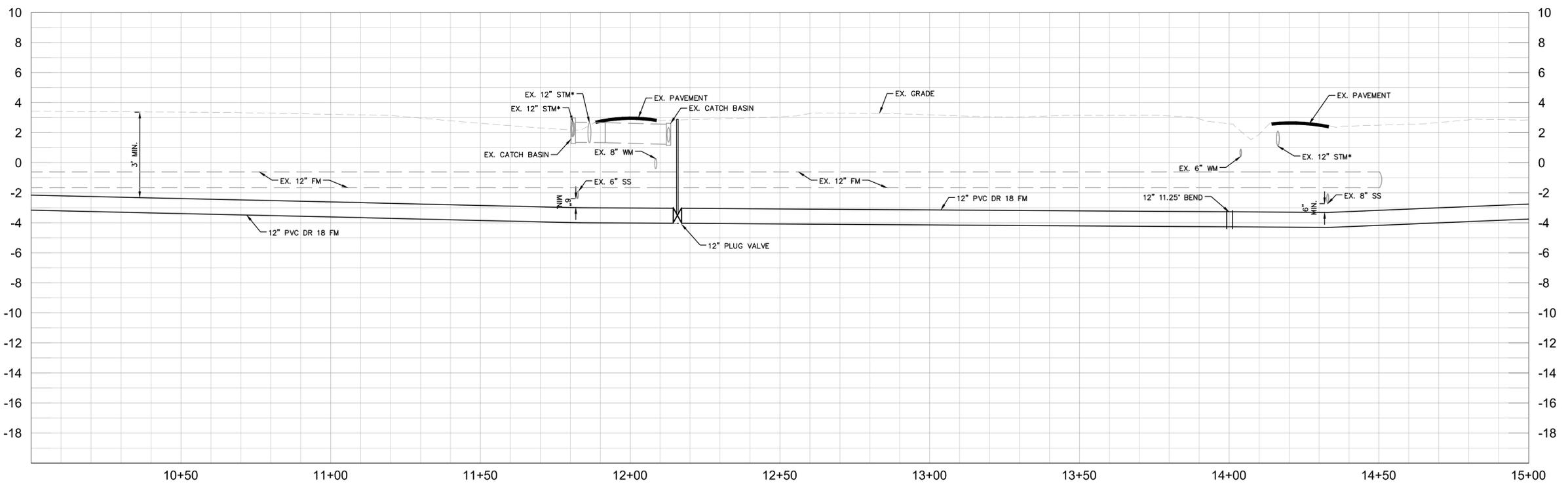

No.	REVISIONS	DATE	BY

**Kimley & Horn**

© 2017 KIMLEY-HORN AND ASSOCIATES, INC.  
655 NORTH FRANKLIN STREET, SUITE 150, TAMPA, FL 33602  
PHONE: 813-620-1460  
WWW.KIMLEY-HORN.COM CA 00000696

KHA PROJECT  
148400019  
DATE  
10/24/2017  
SCALE AS SHOWN  
DESIGNED BY JWW  
DRAWN BY SAE  
CHECKED BY WWW

**Manatee County**

**FORCE MAIN 11 REPLACEMENT**

MANATEE COUNTY

LICENSED PROFESSIONAL  
W. WADE WOOD, P.E.  
FL LICENSE NUMBER  
69051

**PLAN AND PROFILE PALM DRIVE**

**DRIVE**

SHEET NUMBER  
**7**

This document, together with the concepts and designs presented herein, is intended only for the specific purpose and client for which it was prepared. Reuse of and improper reliance on this document without written authorization and approval by Kimley-Horn and Associates, Inc. shall be without liability to Kimley-Horn and Associates, Inc.

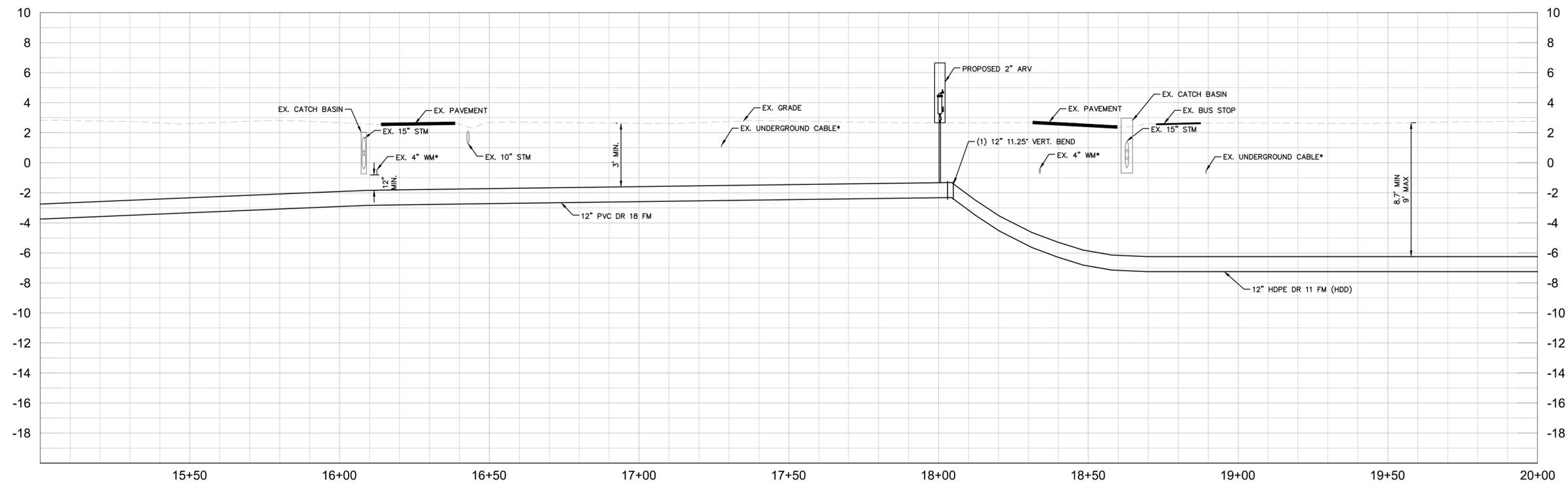
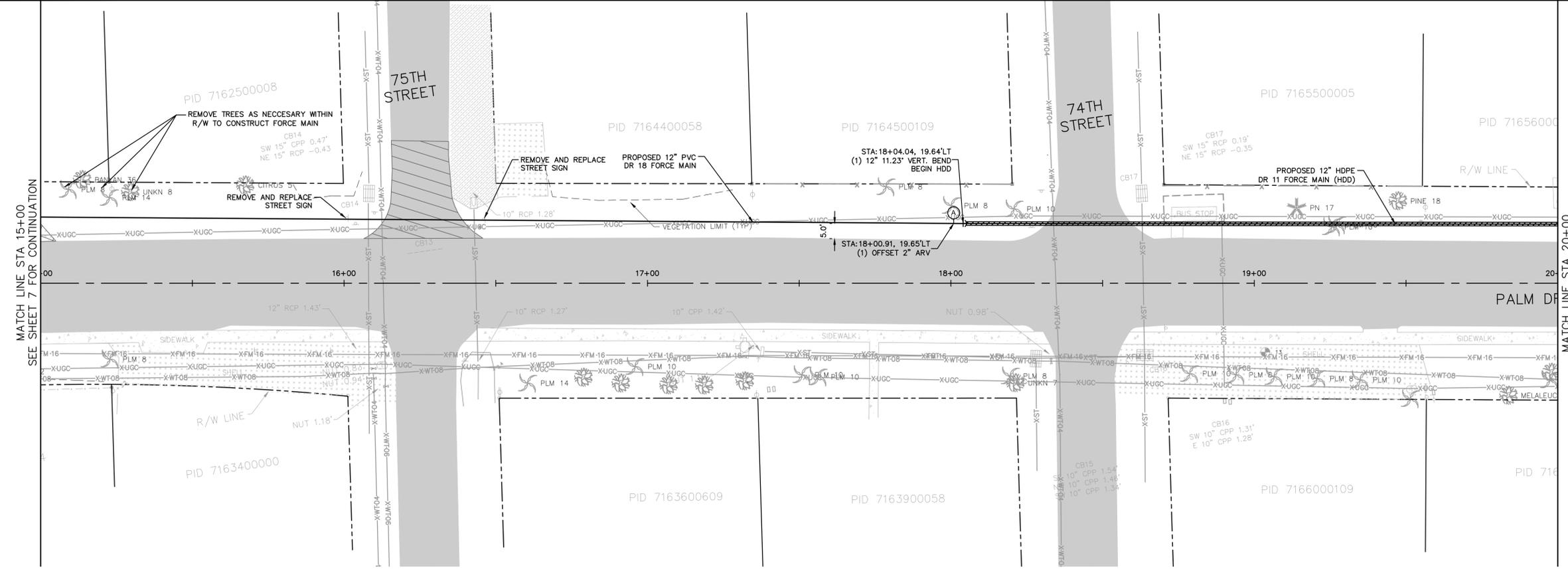
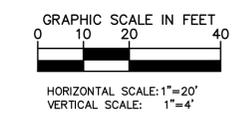

**LEGEND**

- DRIVEWAY REMOVAL
- ROADWAY RESTORATION

**NOTES:**

1. CONTRACTOR TO FOLLOW RESTRAINED LENGTHS SET IN RESTRAIN LENGTH DETAILS ON SHEET 19.
2. CONSTRUCTION DEWATERING SHALL BE CONDUCTED IN ACCORDANCE WITH ALL FEDERAL, STATE, AND LOCAL REQUIREMENTS INCLUDING BUT NOT LIMITED TO CHAPTERS 62-621.300 AND 62-620 OF THE FLORIDA ADMINISTRATIVE CODE (FAC).
3. REFER TO DETAIL UG-12 SHEET 18 FOR COUNTY ROADWAY REPAIR REQUIREMENTS
4. REFER TO DRIVEWAY RESTORATION DETAIL SHEET 20, FOR CITY RESTORATION REQUIREMENTS.

**\*NOTES:**  
THE ELEVATIONS OF THE UTILITIES MARKED WITH AN ASTERISK (\*) HAVE BEEN ASSUMED ON THE BASIS OF TYPICAL ANTICIPATED SOIL COVERAGE. CONTRACTOR SHALL NOT RELY ON THIS INFORMATION FOR CONSTRUCTION, BUT SHALL BE RESPONSIBLE FOR FIELD LOCATIONS (HORIZONTAL AND VERTICAL) OF ALL UTILITIES CROSSING THE PROPOSED FORCE MAIN. CONTRACTOR SHALL INCLUDE IN THE UNIT COST OF THE SUBJECT FORCE MAIN CONSTRUCTION, THE COST OF UTILITY ADJUSTMENTS NECESSARY TO ATTAIN DESIGN MINIMUM SEPARATION FOR UTILITIES CONFLICTING WITH THE CONSTRUCTION OF THE PROPOSED FORCE MAIN. INTERRUPTIONS OF ANY EXISTING UTILITY SERVICES SHALL BE NOTICED TO EFFECTED CUSTOMERS A MINIMUM OF 48 HOURS IN ADVANCE AND SHALL NOT EXCEED 4 HOURS IN DURATION.

WHERE CONCRETE REPAIRS ARE NECESSARY AND EXPANSION JOINTS ARE PRESENT, CONTRACTOR TO REMOVE AND REPLACE CONCRETE UP TO THE NEXT EXPANSION JOINT; OTHERWISE, REPLACE CONCRETE AS NECESSARY.

**GROUNDWATER / DEWATERING NOTE:**  
THE PRESENCE OF GROUNDWATER SHOULD BE ANTICIPATED ON THIS PROJECT. CONTRACTOR'S BID SHALL INCLUDE CONSIDERATION FOR THIS ISSUE. WHEN PERFORMING GRADING OPERATIONS DURING PERIODS OF WET WEATHER, PROVIDE ADEQUATE DEWATERING, DRAINAGE AND GROUND WATER MANAGEMENT TO CONTROL MOISTURE OF SOILS.



No.	REVISIONS	DATE	BY

**Kimley & Horn**

© 2017 KIMLEY-HORN AND ASSOCIATES, INC.  
655 NORTH FRANKLIN STREET, SUITE 150, TAMPA, FL 33602  
PHONE: 813-620-1460  
WWW.KIMLEY-HORN.COM CA 00000696

KHA PROJECT 148400019
DATE 10/24/2017
SCALE AS SHOWN
DESIGNED BY JWW
DRAWN BY SAE
CHECKED BY WWW

**Manatee County**  
FLORIDA

**FORCE MAIN 11 REPLACEMENT**

MANATEE COUNTY

LICENSED PROFESSIONAL
W. WADE WOOD, P.E.
FL LICENSE NUMBER 69051
FL DATE:

**PLAN AND PROFILE  
PALM DRIVE**

SHEET NUMBER  
**8**

This document, together with the concepts and designs presented herein, is an instrument of service intended only for the specific purpose and client for which it was prepared. Reuse of and improper reliance on this document without written authorization and approval by Kimley-Horn and Associates, Inc. shall be without liability to Kimley-Horn and Associates, Inc.

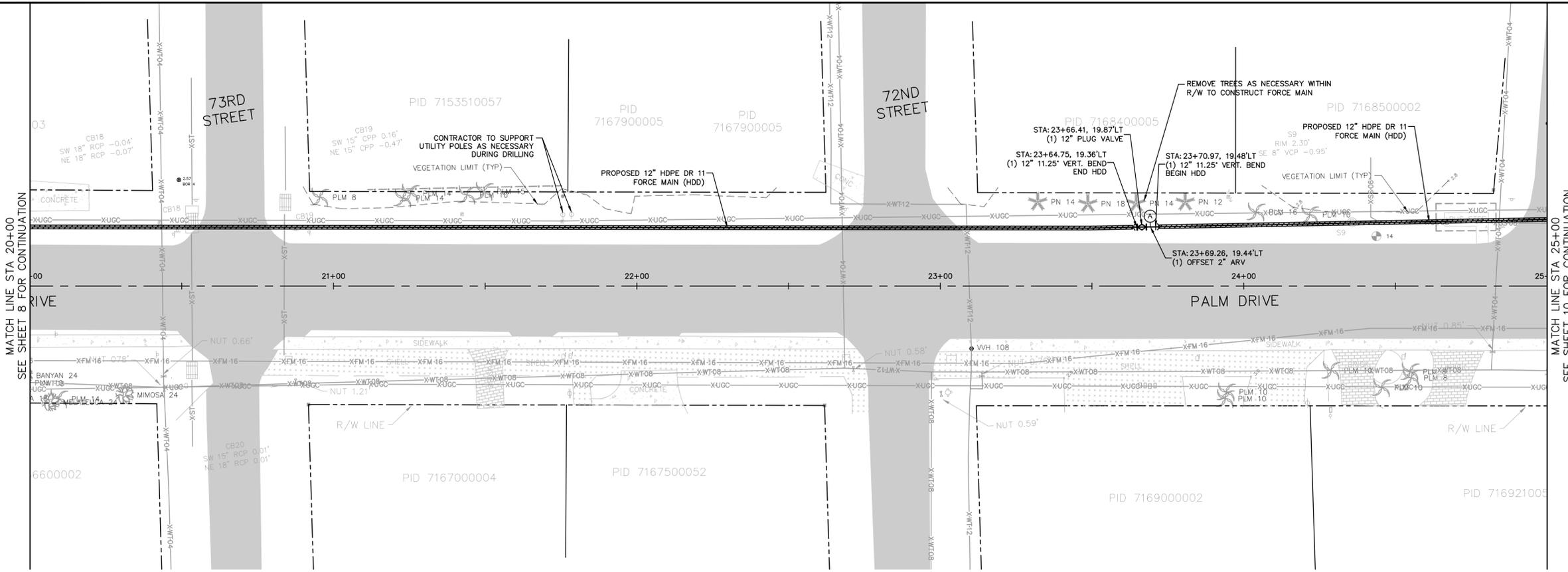
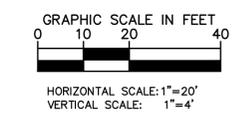

**LEGEND**

- DRIVEWAY REMOVAL
- ROADWAY RESTORATION

**NOTES:**

1. CONTRACTOR TO FOLLOW RESTRAINED LENGTHS SET IN RESTRAIN LENGTH DETAILS ON SHEET 19.
2. CONSTRUCTION DEWATERING SHALL BE CONDUCTED IN ACCORDANCE WITH ALL FEDERAL, STATE, AND LOCAL REQUIREMENTS INCLUDING BUT NOT LIMITED TO CHAPTERS 62-621.300 AND 62-620 OF THE FLORIDA ADMINISTRATIVE CODE (FAC).
3. REFER TO DETAIL UG-12 SHEET 18 FOR COUNTY ROADWAY REPAIR REQUIREMENTS
4. REFER TO DRIVEWAY RESTORATION DETAIL SHEET 20, FOR CITY RESTORATION REQUIREMENTS.

**\*NOTES:**  
THE ELEVATIONS OF THE UTILITIES MARKED WITH AN ASTERISK (\*) HAVE BEEN ASSUMED ON THE BASIS OF TYPICAL ANTICIPATED SOIL COVERAGE. CONTRACTOR SHALL NOT RELY ON THIS INFORMATION FOR CONSTRUCTION, BUT SHALL BE RESPONSIBLE FOR FIELD LOCATIONS (HORIZONTAL AND VERTICAL) OF ALL UTILITIES CROSSING THE PROPOSED FORCE MAIN. CONTRACTOR SHALL INCLUDE IN THE UNIT COST OF THE SUBJECT FORCE MAIN CONSTRUCTION, THE COST OF UTILITY ADJUSTMENTS NECESSARY TO ATTAIN DESIGN MINIMUM SEPARATION FOR UTILITIES CONFLICTING WITH THE CONSTRUCTION OF THE PROPOSED FORCE MAIN. INTERRUPTIONS OF ANY EXISTING UTILITY SERVICES SHALL BE NOTICED TO EFFECTED CUSTOMERS A MINIMUM OF 48 HOURS IN ADVANCE AND SHALL NOT EXCEED 4 HOURS IN DURATION.

WHERE CONCRETE REPAIRS ARE NECESSARY AND EXPANSION JOINTS ARE PRESENT, CONTRACTOR TO REMOVE AND REPLACE CONCRETE UP TO THE NEXT EXPANSION JOINT; OTHERWISE, REPLACE CONCRETE AS NECESSARY.

**GROUNDWATER / DEWATERING NOTE:**  
THE PRESENCE OF GROUNDWATER SHOULD BE ANTICIPATED ON THIS PROJECT. CONTRACTOR'S BID SHALL INCLUDE CONSIDERATION FOR THIS ISSUE. WHEN PERFORMING GRADING OPERATIONS DURING PERIODS OF WET WEATHER, PROVIDE ADEQUATE DEWATERING, DRAINAGE AND GROUND WATER MANAGEMENT TO CONTROL MOISTURE OF SOILS.



No.	REVISIONS	DATE	BY

**Kimley & Horn**  
© 2017 KIMLEY-HORN AND ASSOCIATES, INC.  
655 NORTH FRANKLIN STREET, SUITE 150, TAMPA, FL 33602  
PHONE: 813-620-1460  
WWW.KIMLEY-HORN.COM CA 00000696

KHA PROJECT 148400019
DATE 10/24/2017
SCALE AS SHOWN
DESIGNED BY JWW
DRAWN BY SAE
CHECKED BY WWW

**Manatee County Florida**  
**FORCE MAIN 11 REPLACEMENT**  
MANATEE COUNTY

LICENSED PROFESSIONAL
W. WADE WOOD, P.E.
FL LICENSE NUMBER 69051
FL DATE:

**PLAN AND PROFILE PALM DRIVE**

SHEET NUMBER
9

This document, together with the concepts and designs presented herein, is an instrument of service intended only for the specific purpose and client for which it was prepared. Reuse of and improper reliance on this document without written authorization and approval by Kimley-Horn and Associates, Inc. shall be without liability to Kimley-Horn and Associates, Inc.

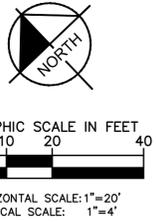
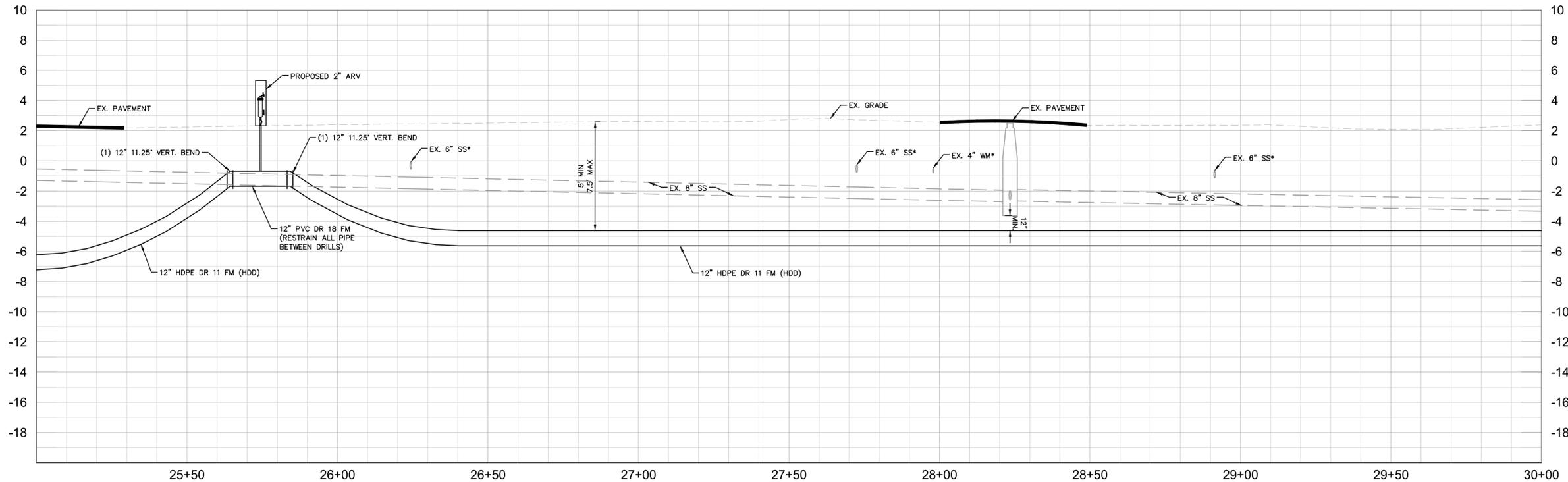
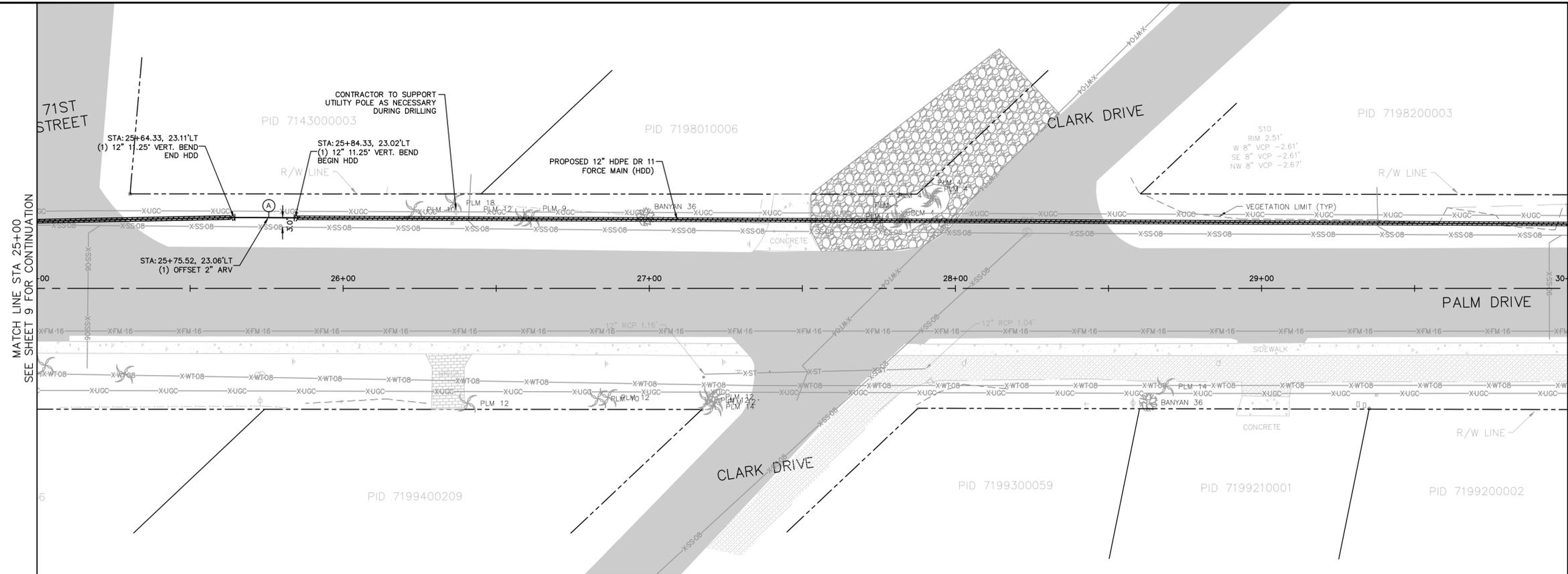

**LEGEND**

- DRIVEWAY REMOVAL
- ROADWAY RESTORATION

**NOTES:**

1. CONTRACTOR TO FOLLOW RESTRAINED LENGTHS SET IN RESTRAIN LENGTH DETAILS ON SHEET 19.
2. CONSTRUCTION DEWATERING SHALL BE CONDUCTED IN ACCORDANCE WITH ALL FEDERAL, STATE, AND LOCAL REQUIREMENTS INCLUDING BUT NOT LIMITED TO CHAPTERS 62-621.300 AND 62-620 OF THE FLORIDA ADMINISTRATIVE CODE (FAC).
3. REFER TO DETAIL UG-12 SHEET 18 FOR COUNTY ROADWAY REPAIR REQUIREMENTS
4. REFER TO DRIVEWAY RESTORATION DETAIL SHEET 20, FOR CITY RESTORATION REQUIREMENTS.

**\*NOTES:**  
 THE ELEVATIONS OF THE UTILITIES MARKED WITH AN ASTERISK (\*) HAVE BEEN ASSUMED ON THE BASIS OF TYPICAL ANTICIPATED SOIL COVERAGE. CONTRACTOR SHALL NOT RELY ON THIS INFORMATION FOR CONSTRUCTION, BUT SHALL BE RESPONSIBLE FOR FIELD LOCATIONS (HORIZONTAL AND VERTICAL) OF ALL UTILITIES CROSSING THE PROPOSED FORCE MAIN. CONTRACTOR SHALL INCLUDE IN THE UNIT COST OF THE SUBJECT FORCE MAIN CONSTRUCTION, THE COST OF UTILITY ADJUSTMENTS NECESSARY TO ATTAIN DESIGN MINIMUM SEPARATION FOR UTILITIES CONFLICTING WITH THE CONSTRUCTION OF THE PROPOSED FORCE MAIN. INTERRUPTIONS OF ANY EXISTING UTILITY SERVICES SHALL BE NOTICED TO EFFECTED CUSTOMERS A MINIMUM OF 48 HOURS IN ADVANCE AND SHALL NOT EXCEED 4 HOURS IN DURATION.

WHERE CONCRETE REPAIRS ARE NECESSARY AND EXPANSION JOINTS ARE PRESENT, CONTRACTOR TO REMOVE AND REPLACE CONCRETE UP TO THE NEXT EXPANSION JOINT; OTHERWISE, REPLACE CONCRETE AS NECESSARY.

**GROUNDWATER / DEWATERING NOTE:**  
 THE PRESENCE OF GROUNDWATER SHOULD BE ANTICIPATED ON THIS PROJECT. CONTRACTOR'S BID SHALL INCLUDE CONSIDERATION FOR THIS ISSUE. WHEN PERFORMING GRADING OPERATIONS DURING PERIODS OF WET WEATHER, PROVIDE ADEQUATE DEWATERING, DRAINAGE AND GROUND WATER MANAGEMENT TO CONTROL MOISTURE OF SOILS.



No.	REVISIONS	DATE	BY

**Kimley & Horn**

© 2017 KIMLEY-HORN AND ASSOCIATES, INC.  
 655 NORTH FRANKLIN STREET, SUITE 150, TAMPA, FL 33602  
 PHONE: 813-620-1460  
 WWW.KIMLEY-HORN.COM CA 00000696

KHA PROJECT  
 148400019  
 DATE  
 10/24/2017  
 SCALE AS SHOWN  
 DESIGNED BY JWW  
 DRAWN BY SAE  
 CHECKED BY WWW

**Manatee County**  
 FLORIDA

**FORCE MAIN 11 REPLACEMENT**

MANATEE COUNTY

LICENSED PROFESSIONAL  
 W. WADE WOOD, P.E.  
 FL LICENSE NUMBER  
 69051

**PLAN AND PROFILE PALM DRIVE**

SHEET NUMBER  
**10**

This document, together with the concepts and designs presented herein, is intended only for the specific purpose and client for which it was prepared. Reuse of and improper reliance on this document without written authorization and approval by Kimley-Horn and Associates, Inc. shall be without liability to Kimley-Horn and Associates, Inc.

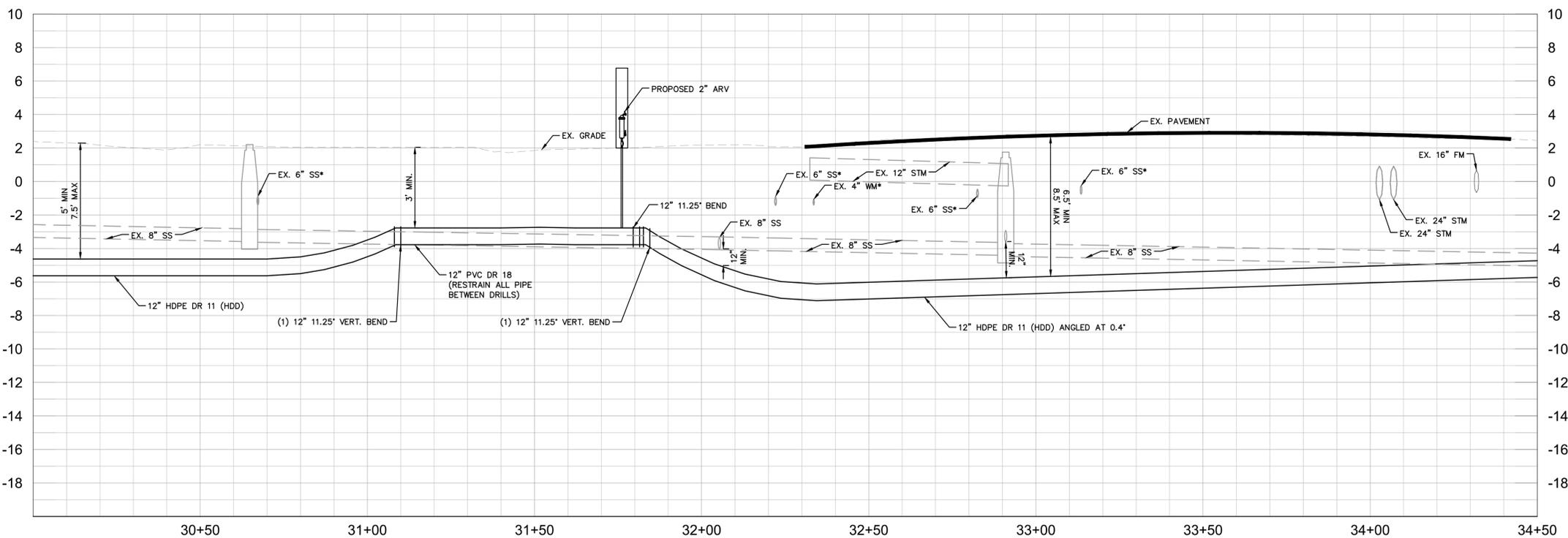
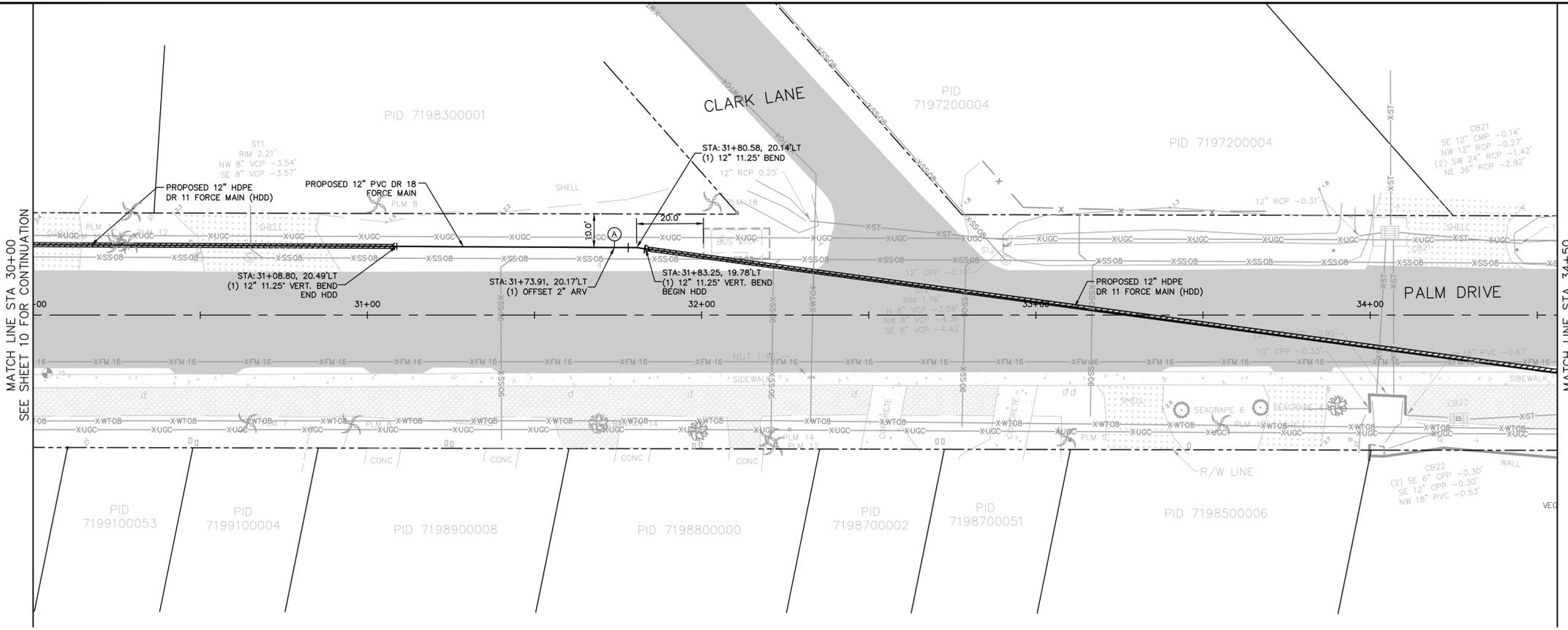
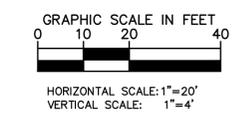

**LEGEND**

- DRIVEWAY REMOVAL
- ROADWAY RESTORATION

**NOTES:**

1. CONTRACTOR TO FOLLOW RESTRAINED LENGTHS SET IN RESTRAIN LENGTH DETAILS ON SHEET 19.
2. CONSTRUCTION DEWATERING SHALL BE CONDUCTED IN ACCORDANCE WITH ALL FEDERAL, STATE, AND LOCAL REQUIREMENTS INCLUDING BUT NOT LIMITED TO CHAPTERS 62-621.300 AND 62-620 OF THE FLORIDA ADMINISTRATIVE CODE (FAC).
3. REFER TO DETAIL UG-12 SHEET 18 FOR COUNTY ROADWAY REPAIR REQUIREMENTS.
4. REFER TO DRIVEWAY RESTORATION DETAIL SHEET 20, FOR CITY RESTORATION REQUIREMENTS.

**\*NOTES:**  
 THE ELEVATIONS OF THE UTILITIES MARKED WITH AN ASTERISK (\*) HAVE BEEN ASSUMED ON THE BASIS OF TYPICAL ANTICIPATED SOIL COVERAGE. CONTRACTOR SHALL NOT RELY ON THIS INFORMATION FOR CONSTRUCTION, BUT SHALL BE RESPONSIBLE FOR FIELD LOCATIONS (HORIZONTAL AND VERTICAL) OF ALL UTILITIES CROSSING THE PROPOSED FORCE MAIN. CONTRACTOR SHALL INCLUDE IN THE UNIT COST OF THE SUBJECT FORCE MAIN CONSTRUCTION, THE COST OF UTILITY ADJUSTMENTS NECESSARY TO ATTAIN DESIGN MINIMUM SEPARATION FOR UTILITIES CONFLICTING WITH THE CONSTRUCTION OF THE PROPOSED FORCE MAIN. INTERRUPTIONS OF ANY EXISTING UTILITY SERVICES SHALL BE NOTICED TO EFFECTED CUSTOMERS A MINIMUM OF 48 HOURS IN ADVANCE AND SHALL NOT EXCEED 4 HOURS IN DURATION.

WHERE CONCRETE REPAIRS ARE NECESSARY AND EXPANSION JOINTS ARE PRESENT, CONTRACTOR TO REMOVE AND REPLACE CONCRETE UP TO THE NEXT EXPANSION JOINT; OTHERWISE, REPLACE CONCRETE AS NECESSARY.

**GROUNDWATER / DEWATERING NOTE:**  
 THE PRESENCE OF GROUNDWATER SHOULD BE ANTICIPATED ON THIS PROJECT. CONTRACTOR'S BID SHALL INCLUDE CONSIDERATION FOR THIS ISSUE. WHEN PERFORMING GRADING OPERATIONS DURING PERIODS OF WET WEATHER, PROVIDE ADEQUATE DEWATERING, DRAINAGE AND GROUND WATER MANAGEMENT TO CONTROL MOISTURE OF SOILS.



No.	REVISIONS	DATE	BY

**Kimley & Horn**  
 © 2017 KIMLEY-HORN AND ASSOCIATES, INC.  
 655 NORTH FRANKLIN STREET, SUITE 150, TAMPA, FL 33602  
 PHONE: 813-620-1460  
 WWW.KIMLEY-HORN.COM CA 00000696

KHA PROJECT  
 148400019  
 DATE  
 10/24/2017  
 SCALE AS SHOWN  
 DESIGNED BY JWW  
 DRAWN BY SAE  
 CHECKED BY WWW

**Manatee County**  
**FLORIDA**  
**FORCE MAIN 11 REPLACEMENT**  
 MANATEE COUNTY

LICENSED PROFESSIONAL  
 W. WADE WOOD, P.E.  
 FL LICENSE NUMBER  
 69051

**PLAN AND PROFILE PALM DRIVE**

SHEET NUMBER  
**11**



This document, together with the concepts and designs presented herein, is intended only for the specific purpose and client for which it was prepared. Reuse of and improper reliance on this document without written authorization and adaptation by Kimley-Horn and Associates, Inc. shall be without liability to Kimley-Horn and Associates, Inc.

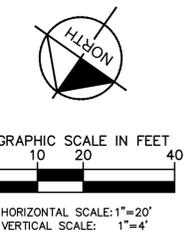
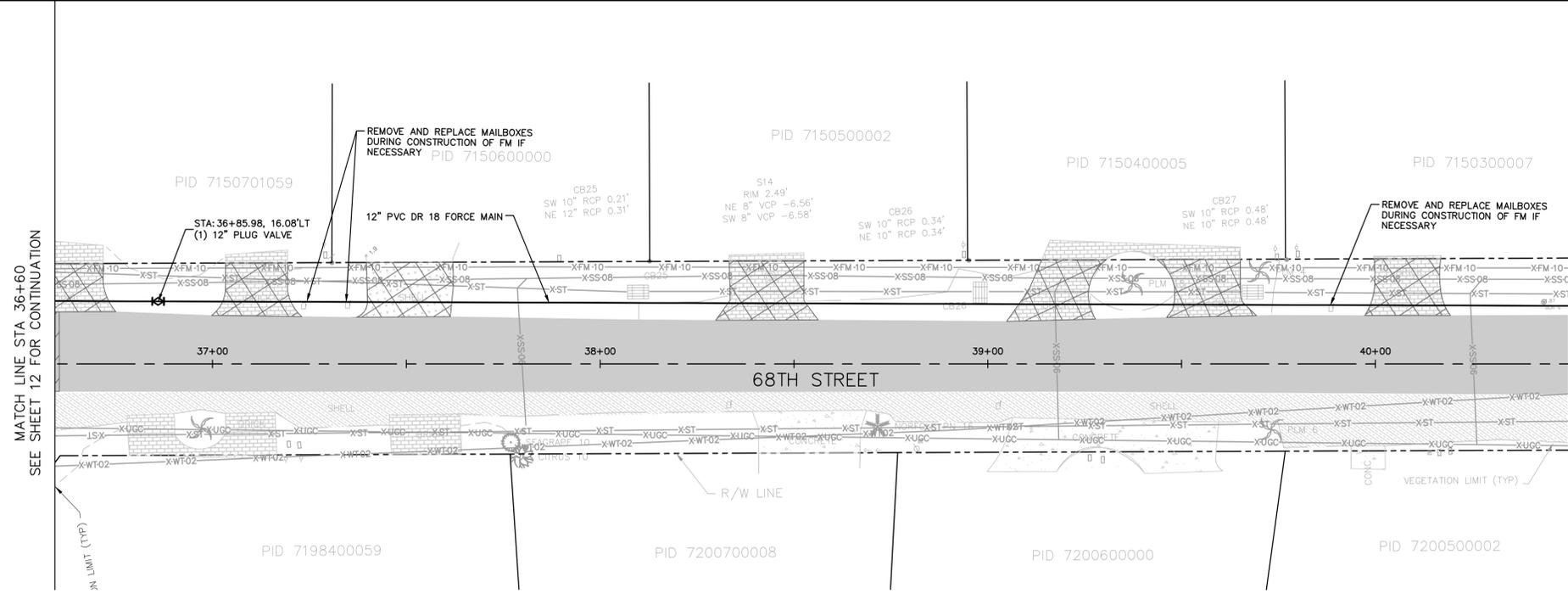

MATCH LINE STA 36+60  
SEE SHEET 12 FOR CONTINUATION

MATCH LINE STA 40+50  
SEE SHEET 14 FOR CONTINUATION



- NOTES:**
- CONTRACTOR TO FOLLOW RESTRAINED LENGTHS SET IN RESTRAIN LENGTH DETAILS ON SHEET 19.
  - CONSTRUCTION DEWATERING SHALL BE CONDUCTED IN ACCORDANCE WITH ALL FEDERAL, STATE, AND LOCAL REQUIREMENTS INCLUDING BUT NOT LIMITED TO CHAPTERS 62-621.300 AND 62-620 OF THE FLORIDA ADMINISTRATIVE CODE (FAC).
  - REFER TO DETAIL UG-12 SHEET 18 FOR COUNTY ROADWAY REPAIR REQUIREMENTS
  - REFER TO DRIVEWAY RESTORATION DETAIL SHEET 20, FOR CITY RESTORATION REQUIREMENTS.

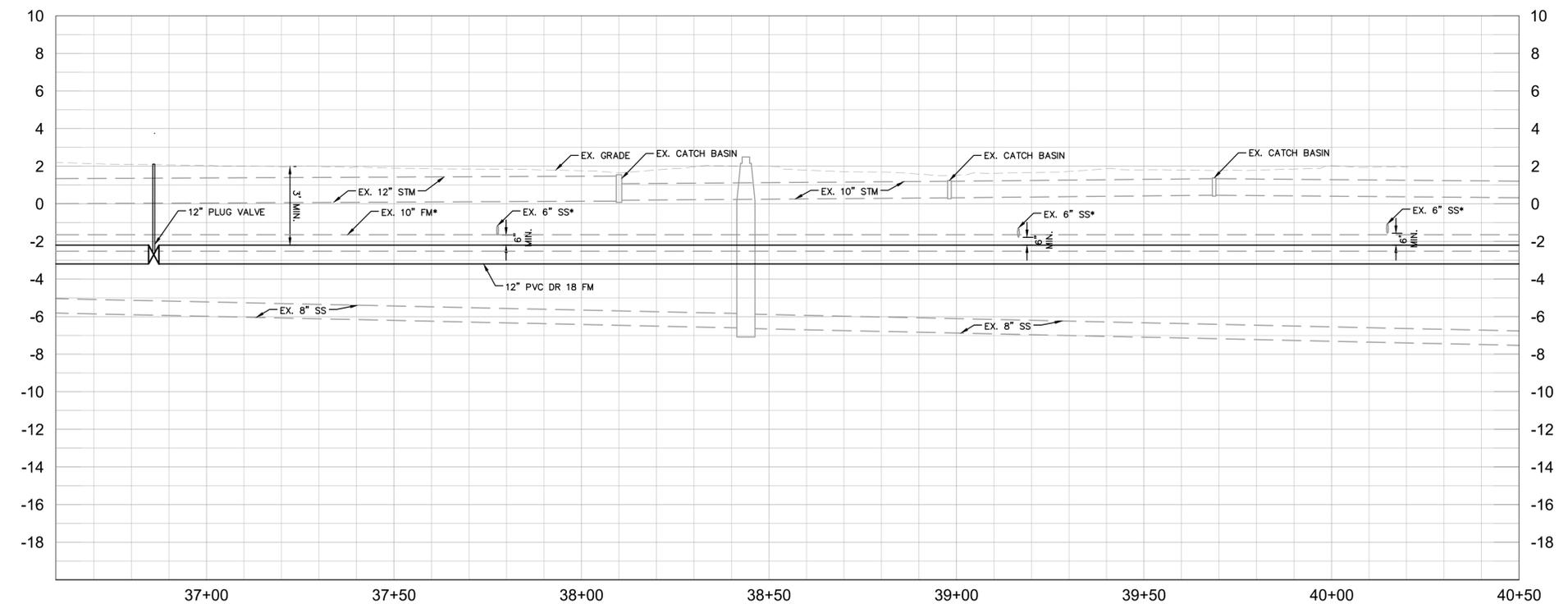

**\*NOTES:**  
THE ELEVATIONS OF THE UTILITIES MARKED WITH AN ASTERISK (\*) HAVE BEEN ASSUMED ON THE BASIS OF TYPICAL ANTICIPATED SOIL COVERAGE. CONTRACTOR SHALL NOT RELY ON THIS INFORMATION FOR CONSTRUCTION, BUT SHALL BE RESPONSIBLE FOR FIELD LOCATIONS (HORIZONTAL AND VERTICAL) OF ALL UTILITIES CROSSING THE PROPOSED FORCE MAIN. CONTRACTOR SHALL INCLUDE IN THE UNIT COST OF THE SUBJECT FORCE MAIN CONSTRUCTION, THE COST OF UTILITY ADJUSTMENTS NECESSARY TO ATTAIN DESIGN MINIMUM SEPARATION FOR UTILITIES CONFLICTING WITH THE CONSTRUCTION OF THE PROPOSED FORCE MAIN. INTERRUPTIONS OF ANY EXISTING UTILITY SERVICES SHALL BE NOTICED TO EFFECTED CUSTOMERS A MINIMUM OF 48 HOURS IN ADVANCE AND SHALL NOT EXCEED 4 HOURS IN DURATION.

WHERE CONCRETE REPAIRS ARE NECESSARY AND EXPANSION JOINTS ARE PRESENT, CONTRACTOR TO REMOVE AND REPLACE CONCRETE UP TO THE NEXT EXPANSION JOINT; OTHERWISE, REPLACE CONCRETE AS NECESSARY.

**GROUNDWATER / DEWATERING NOTE:**  
THE PRESENCE OF GROUNDWATER SHOULD BE ANTICIPATED ON THIS PROJECT. CONTRACTOR'S BID SHALL INCLUDE CONSIDERATION FOR THIS ISSUE. WHEN PERFORMING GRADING OPERATIONS DURING PERIODS OF WET WEATHER, PROVIDE ADEQUATE DEWATERING, DRAINAGE AND GROUND WATER MANAGEMENT TO CONTROL MOISTURE OF SOILS.



No.	REVISIONS	DATE	BY

**Kimley»Horn**

© 2017 KIMLEY-HORN AND ASSOCIATES, INC.  
655 NORTH FRANKLIN STREET, SUITE 150, TAMPA, FL 33602  
PHONE: 813-620-1460  
WWW.KIMLEY-HORN.COM CA 00000696

KHA PROJECT 148400019
DATE 10/24/2017
SCALE AS SHOWN
DESIGNED BY JWW
DRAWN BY SAE
CHECKED BY WWW

**Manatee County**  
FLORIDA

**FORCE MAIN 11 REPLACEMENT**

MANATEE COUNTY

LICENSED PROFESSIONAL
W. WADE WOOD, P.E.
FL LICENSE NUMBER 69051
FL DATE:

**PLAN AND PROFILE 68TH STREET**

SHEET NUMBER
<b>13</b>

This document, together with the concepts and designs presented herein, is intended only for the specific purpose and client for which it was prepared. Reuse of and improper reliance on this document without written authorization and adaptation by Kimley-Horn and Associates, Inc. shall be without liability to Kimley-Horn and Associates, Inc.

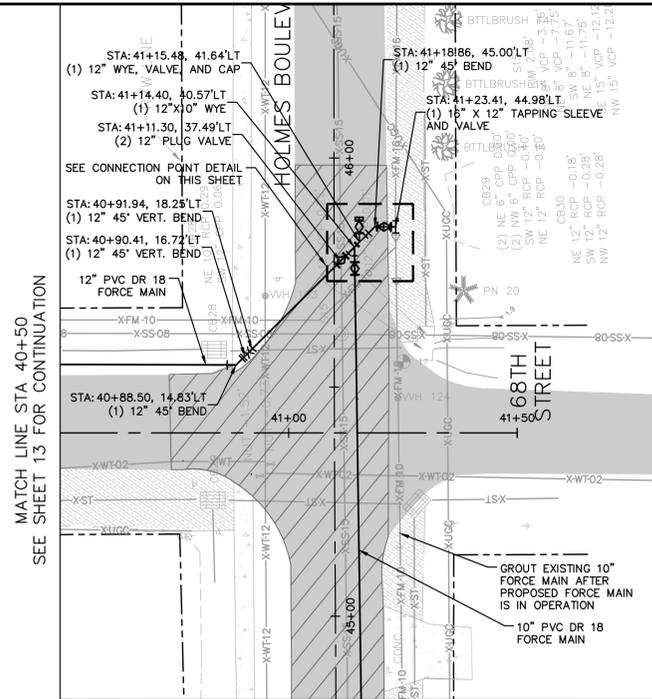

MATCH LINE STA 40+50  
SEE SHEET 13 FOR CONTINUATION

MATCH LINE STA 40+16.89  
SEE SHEET 15 FOR CONTINUATION

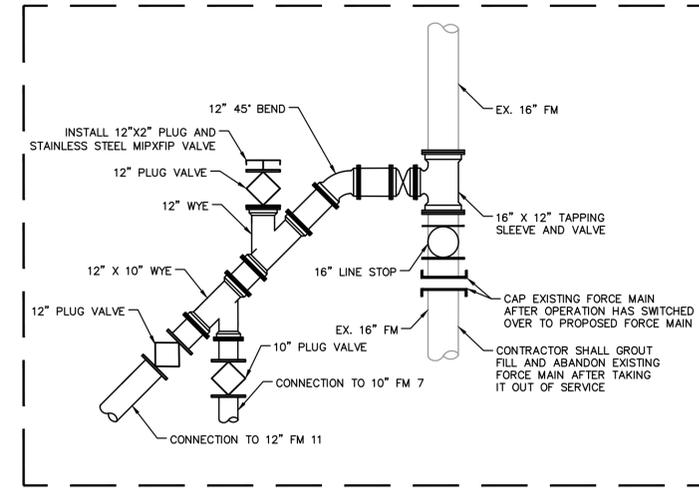

FM 11 AND FM 7 CONNECTION POINT  
SCALE: 1/4"=1'-0"

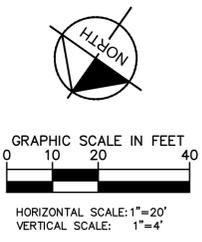

**LEGEND**

DRIVEWAY REMOVAL	
ROADWAY RESTORATION	

- NOTES:**
- CONTRACTOR TO FOLLOW RESTRAINED LENGTHS SET IN RESTRAIN LENGTH DETAILS ON SHEET 19.
  - CONSTRUCTION DEWATERING SHALL BE CONDUCTED IN ACCORDANCE WITH ALL FEDERAL, STATE, AND LOCAL REQUIREMENTS INCLUDING BUT NOT LIMITED TO CHAPTERS 62-621.300 AND 62-620 OF THE FLORIDA ADMINISTRATIVE CODE (FAC).
  - REFER TO DETAIL UG-12 SHEET 18 FOR COUNTY ROADWAY REPAIR REQUIREMENTS
  - REFER TO DRIVEWAY RESTORATION DETAIL SHEET 20, FOR CITY RESTORATION REQUIREMENTS.

**\*NOTES:**  
THE ELEVATIONS OF THE UTILITIES MARKED WITH AN ASTERISK (\*) HAVE BEEN ASSUMED ON THE BASIS OF TYPICAL ANTICIPATED SOIL COVERAGE. CONTRACTOR SHALL NOT RELY ON THIS INFORMATION FOR CONSTRUCTION, BUT SHALL BE RESPONSIBLE FOR FIELD LOCATIONS (HORIZONTAL AND VERTICAL) OF ALL UTILITIES CROSSING THE PROPOSED FORCE MAIN. CONTRACTOR SHALL INCLUDE IN THE UNIT COST OF THE SUBJECT FORCE MAIN CONSTRUCTION, THE COST OF UTILITY ADJUSTMENTS NECESSARY TO ATTAIN DESIGN MINIMUM SEPARATION FOR UTILITIES CONFLICTING WITH THE CONSTRUCTION OF THE PROPOSED FORCE MAIN. INTERRUPTIONS OF ANY EXISTING UTILITY SERVICES SHALL BE NOTICED TO EFFECTED CUSTOMERS A MINIMUM OF 48 HOURS IN ADVANCE AND SHALL NOT EXCEED 4 HOURS IN DURATION.

WHERE CONCRETE REPAIRS ARE NECESSARY AND EXPANSION JOINTS ARE PRESENT, CONTRACTOR TO REMOVE AND REPLACE CONCRETE UP TO THE NEXT EXPANSION JOINT; OTHERWISE, REPLACE CONCRETE AS NECESSARY.

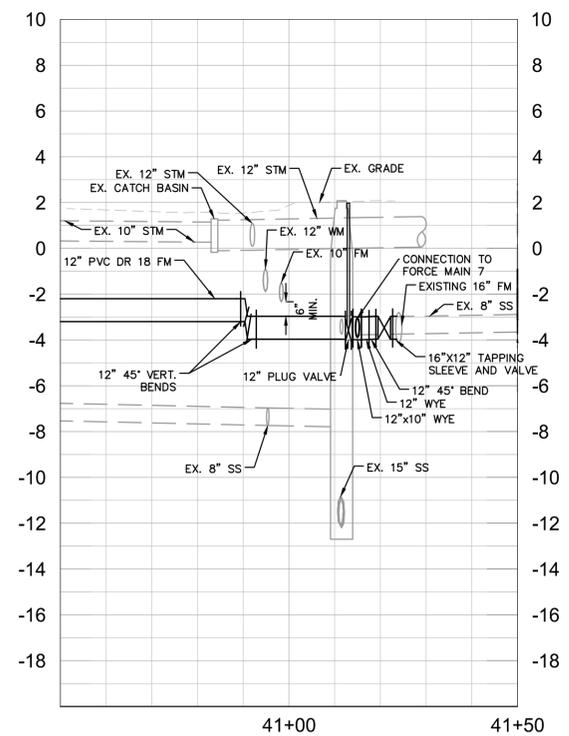

**GROUNDWATER / DEWATERING NOTE:**  
THE PRESENCE OF GROUNDWATER SHOULD BE ANTICIPATED ON THIS PROJECT. CONTRACTOR'S BID SHALL INCLUDE CONSIDERATION FOR THIS ISSUE. WHEN PERFORMING GRADING OPERATIONS DURING PERIODS OF WET WEATHER, PROVIDE ADEQUATE DEWATERING, DRAINAGE AND GROUND WATER MANAGEMENT TO CONTROL MOISTURE OF SOILS.



No.	REVISIONS	DATE	BY

**Kimley & Horn**

© 2017 KIMLEY-HORN AND ASSOCIATES, INC.  
655 NORTH FRANKLIN STREET, SUITE 150, TAMPA, FL 33602  
PHONE: 813-620-1460  
WWW.KIMLEY-HORN.COM CA 00000696

KHA PROJECT 148400019
DATE 10/24/2017
SCALE AS SHOWN
DESIGNED BY JWW
DRAWN BY SAE
CHECKED BY WWW

**Manatee County**  
FLORIDA

**FORCE MAIN 11 REPLACEMENT**

MANATEE COUNTY

LICENSED PROFESSIONAL
W. WADE WOOD, P.E.
FL LICENSE NUMBER 69051
FL DATE:

**PLAN AND PROFILE 68TH STREET & HOLMES BOULEVARD**

SHEET NUMBER
14



This document, together with the concepts and designs presented herein, is intended only for the specific purpose and client for which it was prepared. Reuse of or improper reliance on this document without written authorization and adaptation by Kimley-Horn and Associates, Inc. shall be without liability to Kimley-Horn and Associates, Inc.

PLAN VIEW — EXISTING  
SCALE: 1/2" = 1'-0"

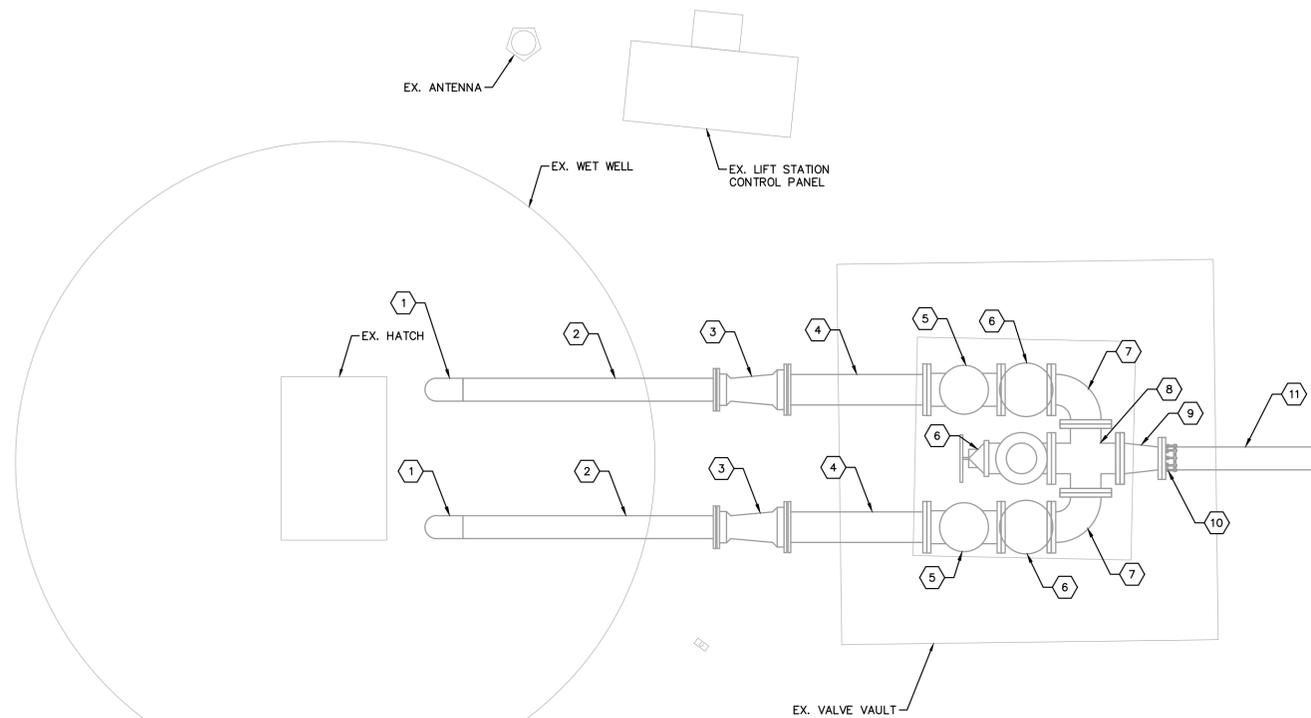

SECTION VIEW — EXISTING  
SCALE: 1/2" = 1'-0"

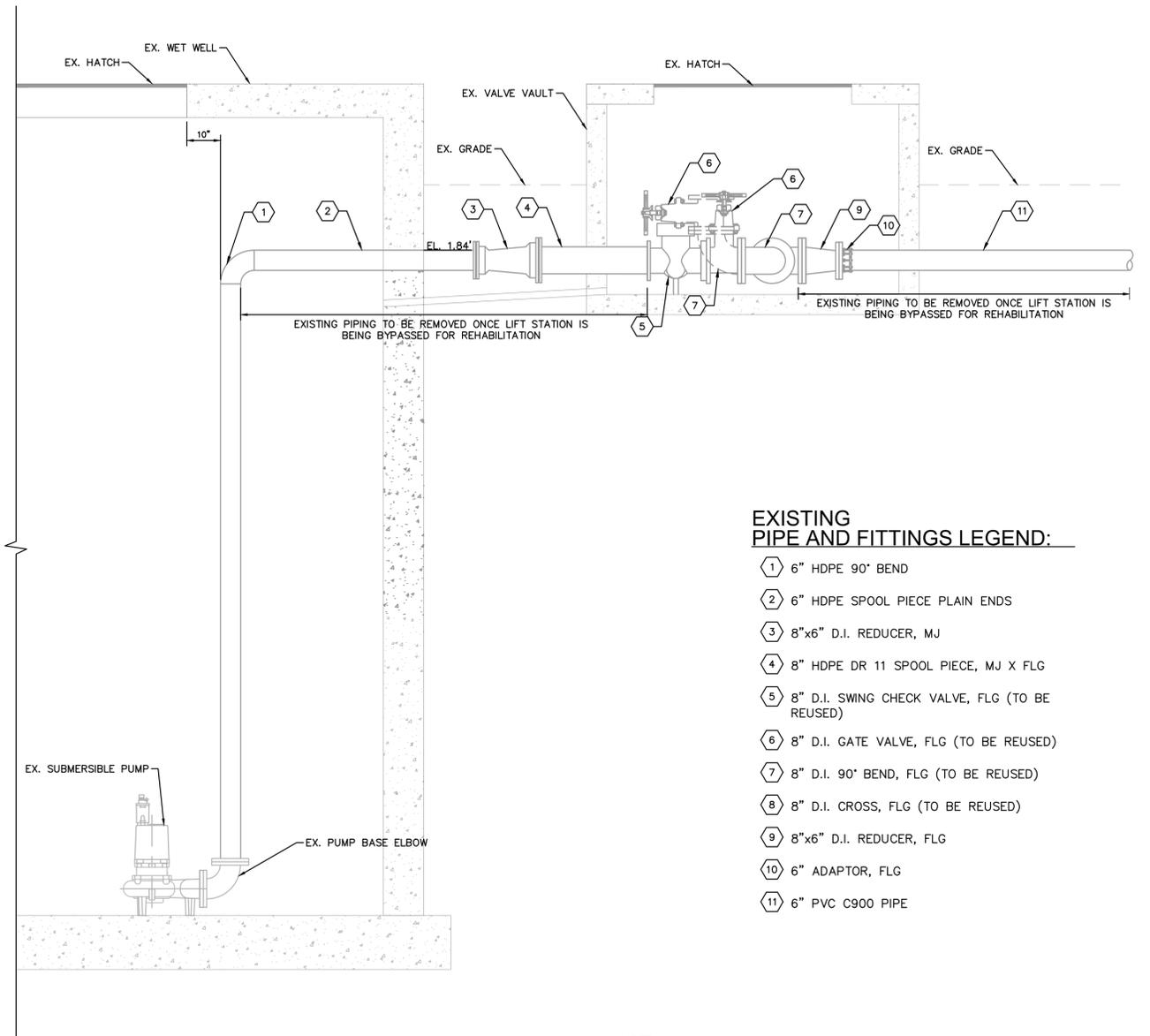

**EXISTING PIPE AND FITTINGS LEGEND:**

- 1 6" HDPE 90° BEND
- 2 6" HDPE SPOOL PIECE PLAIN ENDS
- 3 8"x6" D.I. REDUCER, MJ
- 4 8" HDPE DR 11 SPOOL PIECE, MJ X FLG
- 5 8" D.I. SWING CHECK VALVE, FLG (TO BE REUSED)
- 6 8" D.I. GATE VALVE, FLG (TO BE REUSED)
- 7 8" D.I. 90° BEND, FLG (TO BE REUSED)
- 8 8" D.I. CROSS, FLG (TO BE REUSED)
- 9 8"x6" D.I. REDUCER, FLG
- 10 6" ADAPTOR, FLG
- 11 6" PVC C900 PIPE

- NOTE:
- EXISTING DRAIN PIPE TO BE GROUTED IN PLACE ONCE LIFT STATION IS BEING BYPASSED FOR REHABILITATION.
  - DIMENSIONS PROVIDED WERE TAKEN IN THE FIELD, NOT FROM A SURVEY. CONTRACTOR SHALL FIELD VERIFY ALL LENGTHS AND DIMENSIONS PRIOR TO CONSTRUCTION.

**GROUNDWATER / DEWATERING NOTE:**  
THE PRESENCE OF GROUNDWATER SHOULD BE ANTICIPATED ON THIS PROJECT. CONTRACTOR'S BID SHALL INCLUDE CONSIDERATION FOR THIS ISSUE. WHEN PERFORMING GRADING OPERATIONS DURING PERIODS OF WET WEATHER, PROVIDE ADEQUATE DEWATERING, DRAINAGE AND GROUND WATER MANAGEMENT TO CONTROL MOISTURE OF SOILS.



No.	REVISIONS	DATE	BY

**Kimley»Horn**  
© 2017 KIMLEY-HORN AND ASSOCIATES, INC.  
655 NORTH FRANKLIN STREET, SUITE 150, TAMPA, FL 33602  
PHONE: 813-620-1460  
WWW.KIMLEY-HORN.COM CA 00000696

KHA PROJECT 148400019
DATE 10/24/2017
SCALE AS SHOWN
DESIGNED BY JWW
DRAWN BY SAE
CHECKED BY WWW

**Manatee County**  
**FORCE MAIN 11 REPLACEMENT**  
MANATEE COUNTY

LICENSED PROFESSIONAL
W. WADE WOOD, P.E.
FL LICENSE NUMBER 69051

**EXISTING LS11 PIPING**

SHEET NUMBER
16

This document, together with the concepts and designs presented herein, is an instrument of service, intended only for the specific purpose and client for which it was prepared. Reuse of any portion of this document without written authorization and adaptation by Kimley-Horn and Associates, Inc. shall be without liability to Kimley-Horn and Associates, Inc.

SECTION VIEW – PROPOSED  
SCALE: 1/2" = 1'-0"

PLAN VIEW – PROPOSED  
SCALE: 1/2" = 1'-0"

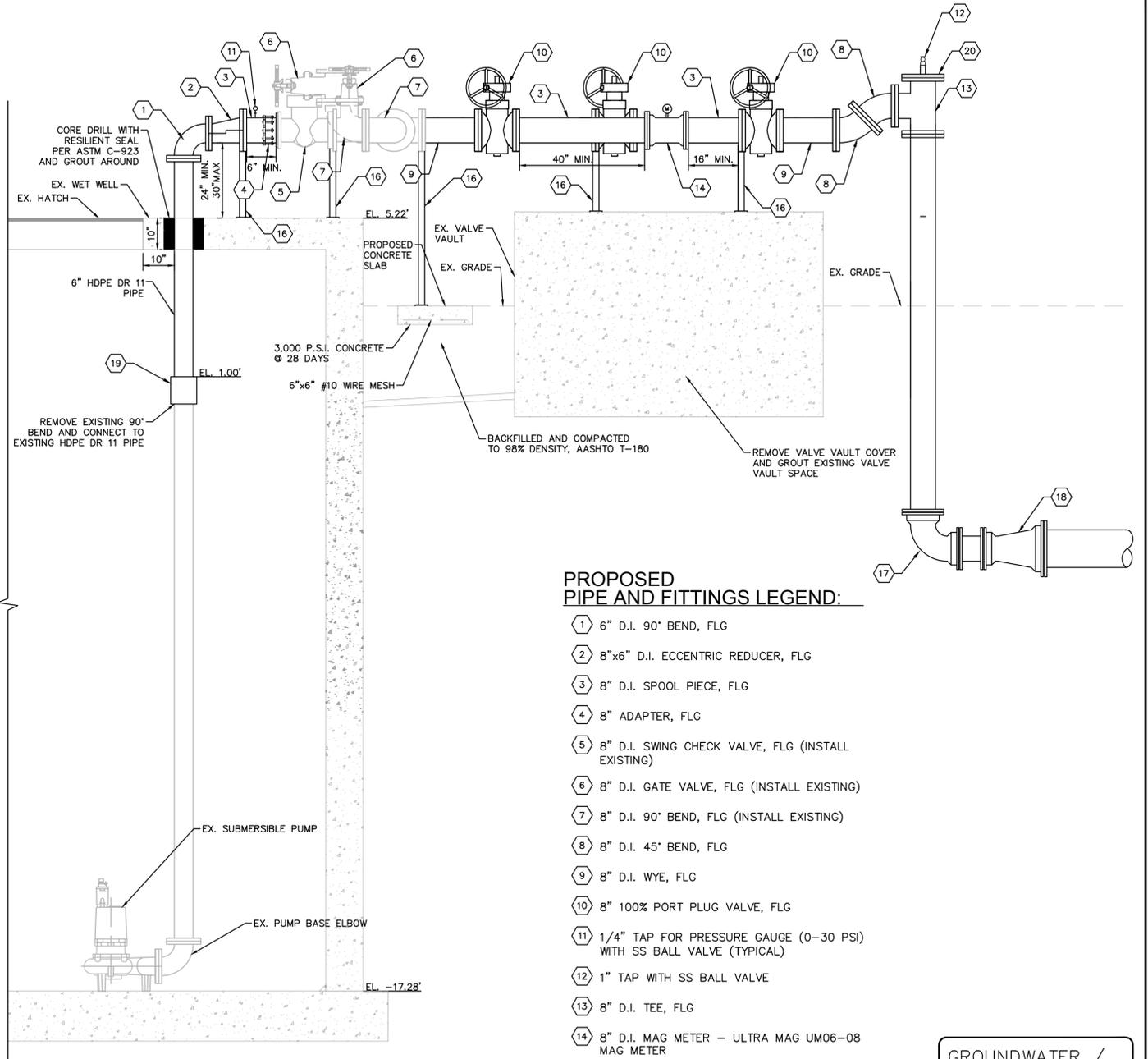
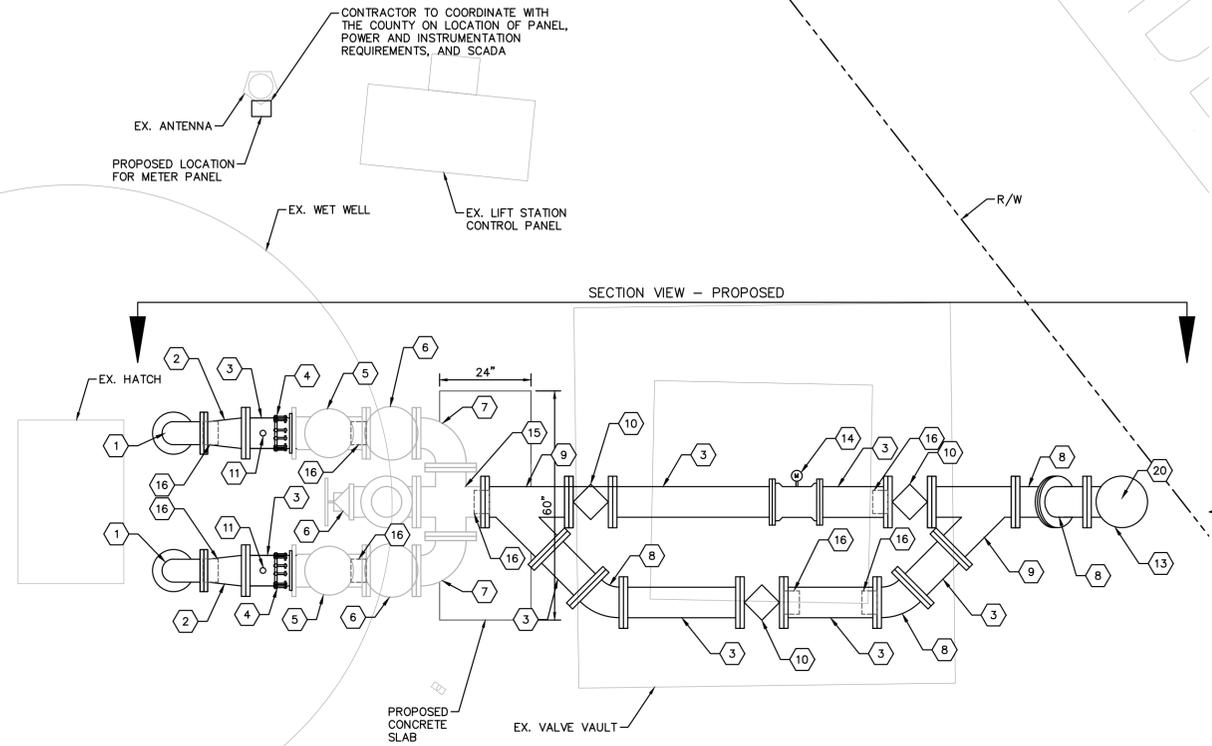

PROPOSED PIPE AND FITTINGS LEGEND:

- ① 6" D.I. 90° BEND, FLG
- ② 8"x6" D.I. ECCENTRIC REDUCER, FLG
- ③ 8" D.I. SPOOL PIECE, FLG
- ④ 8" ADAPTER, FLG
- ⑤ 8" D.I. SWING CHECK VALVE, FLG (INSTALL EXISTING)
- ⑥ 8" D.I. GATE VALVE, FLG (INSTALL EXISTING)
- ⑦ 8" D.I. 90° BEND, FLG (INSTALL EXISTING)
- ⑧ 8" D.I. 45° BEND, FLG
- ⑨ 8" D.I. WYE, FLG
- ⑩ 8" 100% PORT PLUG VALVE, FLG
- ⑪ 1/4" TAP FOR PRESSURE GAUGE (0-30 PSI) WITH SS BALL VALVE (TYPICAL)
- ⑫ 1" TAP WITH SS BALL VALVE
- ⑬ 8" D.I. TEE, FLG
- ⑭ 8" D.I. MAG METER – ULTRA MAG UM06-08 MAG METER
- ⑮ 8" D.I. CROSS, FLG (INSTALL EXISTING)
- ⑯ FLANGE MOUNT PIPE SUPPORT
- ⑰ 8" D.I. 90° BEND, MJ
- ⑱ 12"x8" D.I. REDUCER, MJ
- ⑲ 6" ELECTROFUSION COUPLING
- ⑳ 8" BLIND FLANGE

NOTE:  
1. EXISTING DRAIN PIPE TO BE GROUTED IN PLACE ONCE LIFT STATION IS BEING BYPASSED FOR REHABILITATION.  
2. DIMENSIONS PROVIDED WERE TAKEN IN THE FIELD, NOT FROM A SURVEY. CONTRACTOR SHALL FIELD VERIFY ALL LENGTHS AND DIMENSIONS PRIOR TO CONSTRUCTION.

**GROUNDWATER / DEWATERING NOTE:**  
THE PRESENCE OF GROUNDWATER SHOULD BE ANTICIPATED ON THIS PROJECT. CONTRACTOR'S BID SHALL INCLUDE CONSIDERATION FOR THIS ISSUE. WHEN PERFORMING GRADING OPERATIONS DURING PERIODS OF WET WEATHER, PROVIDE ADEQUATE DEWATERING, DRAINAGE AND GROUND WATER MANAGEMENT TO CONTROL MOISTURE OF SOILS.



No.	REVISIONS	DATE	BY

**Kimley»Horn**  
© 2017 KIMLEY-HORN AND ASSOCIATES, INC.  
655 NORTH FRANKLIN STREET, SUITE 150, TAMPA, FL 33602  
PHONE: 813-620-1460  
WWW.KIMLEY-HORN.COM CA 00000696

KHA PROJECT 148400019
DATE 10/24/2017
SCALE AS SHOWN
DESIGNED BY JWW
DRAWN BY SAE
CHECKED BY WVV

**Manatee County**  
**FORCE MAIN 11 REPLACEMENT**  
MANATEE COUNTY

LICENSED PROFESSIONAL
W. WADE WOOD, P.E.
FL LICENSE NUMBER 69051
FL DATE:

**PROPOSED LS 11  
ABOVEGROUND PIPING**

SHEET NUMBER
17



This document, together with the concepts and designs presented herein, is intended only for the specific purpose and client for which it was prepared. Reuse of any information contained herein without written authorization and approval by Kimley-Horn and Associates, Inc. shall be without liability to Kimley-Horn and Associates, Inc.

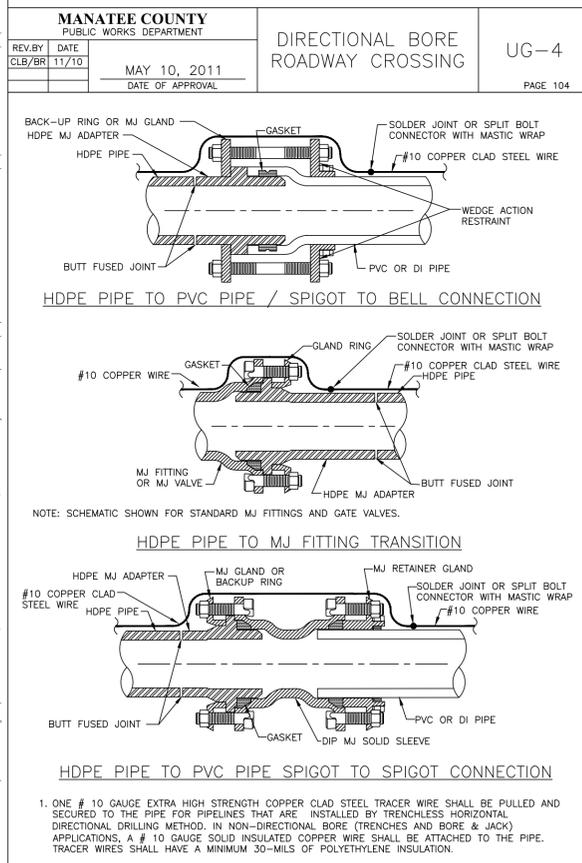
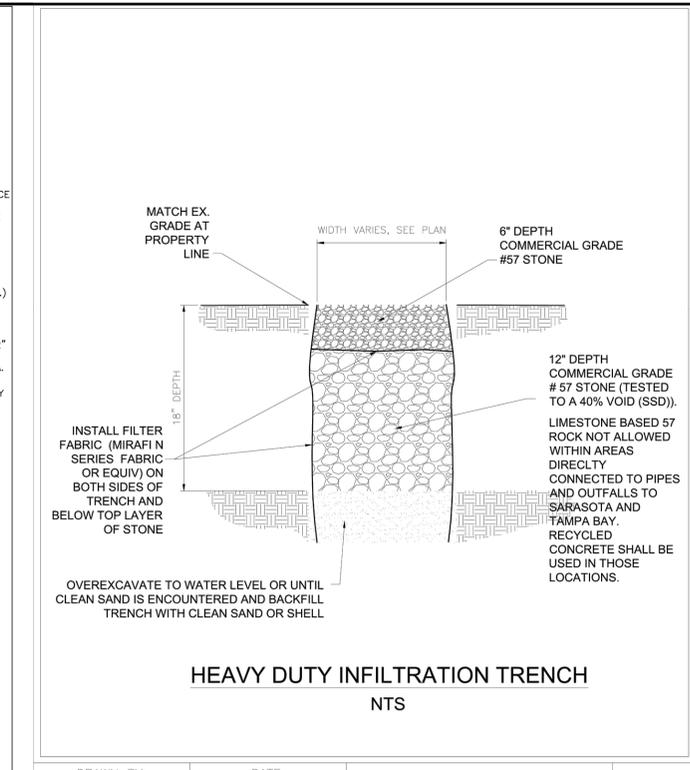
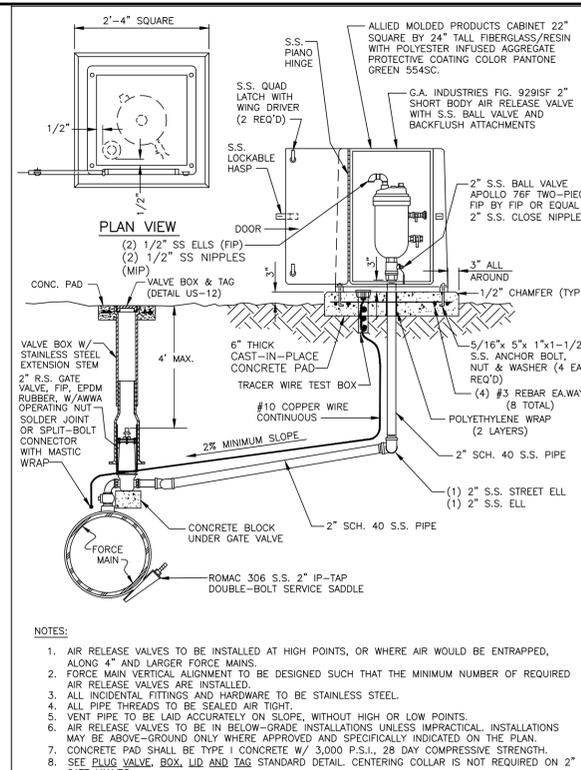
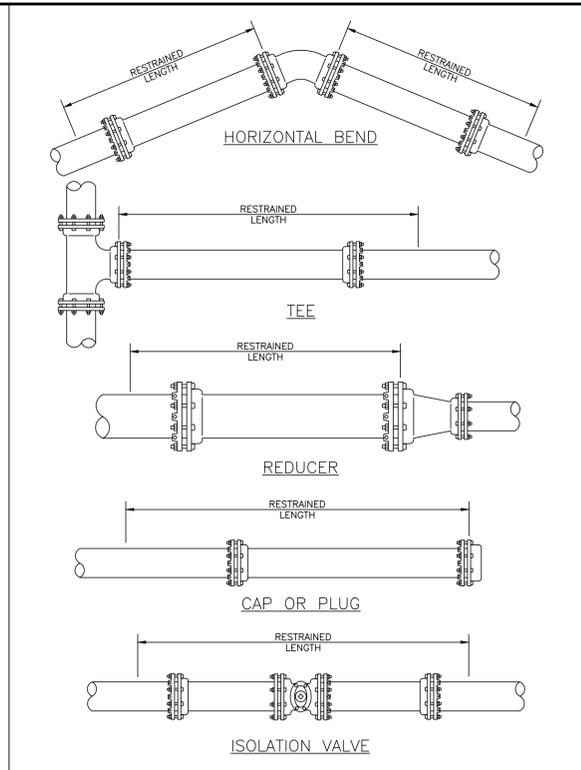
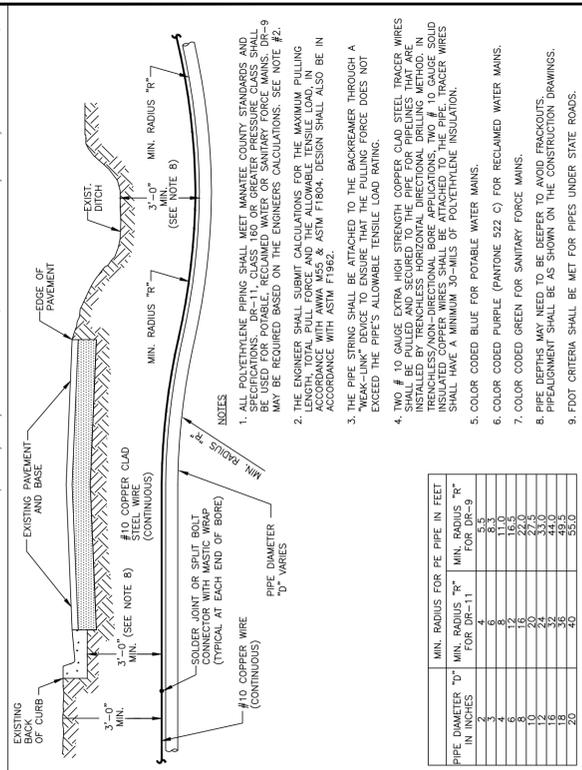

**MANATEE COUNTY PUBLIC WORKS DEPARTMENT**  
**REQUIRED LENGTH OF RESTRAINED JOINT PIPE FOR DR-18 PVC PIPE**  
 UG-8  
 DATE OF APPROVAL: MAY 10, 2011  
 PAGE 108

MAIN PIPE SIZE	HORIZ. BENDS			TEES						REDUCERS			PLUGS & VALVES			
	90°	45°	22.5°	SIZE LENGTH						SIZE LENGTH						
24	90	38	18	X24	X20	X16	X12	X10	X8	X6	X4	X24	X16	X12	138	214
20	78	32	16	X20	X16	X12	X10	X8	X6	X4	X20	X12	X10	X8	149	184
16	66	27	13	X16	X12	X10	X8	X6	X4	X2	X16	X10	X8	X6	111	151
12	52	22	10	X12	X10	X8	X6	X4	X2	X12	X8	X6	X4	X2	86	118
10	44	18	9	X10	X8	X6	X4	X2	X10	X6	X4	X8	X6	X4	81	100
8	37	15	7	X8	X6	X4	X2	X8	X6	X4	X6	X4	X2	60	83	
6	29	12	6	X6	X4	X2	X6	X4	X2	X4	X2	X4	X2	33	63	
4	21	8	4	X4	X2	X4	X2	X4	X2	X4	X2	X4	X2	12	45	

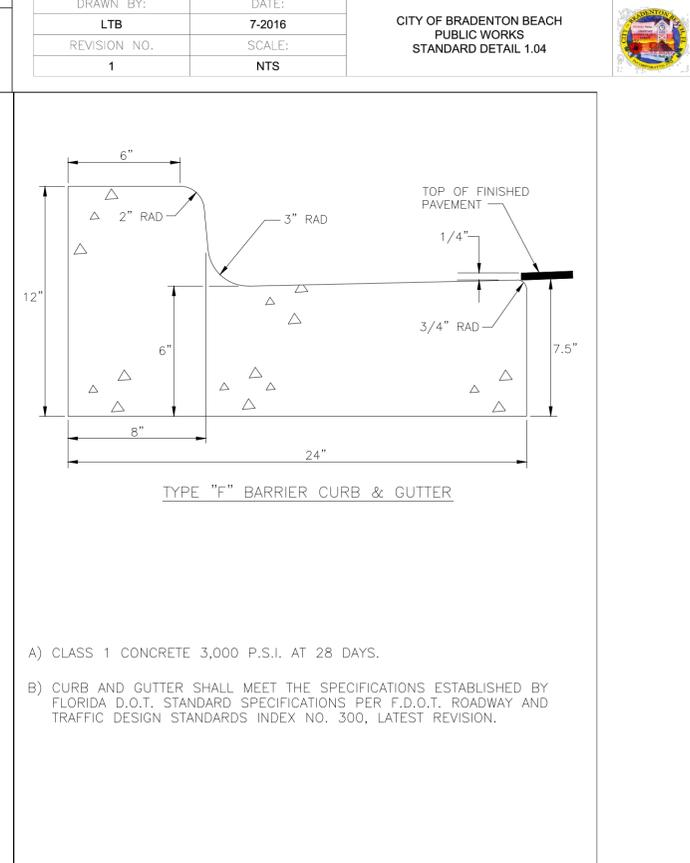
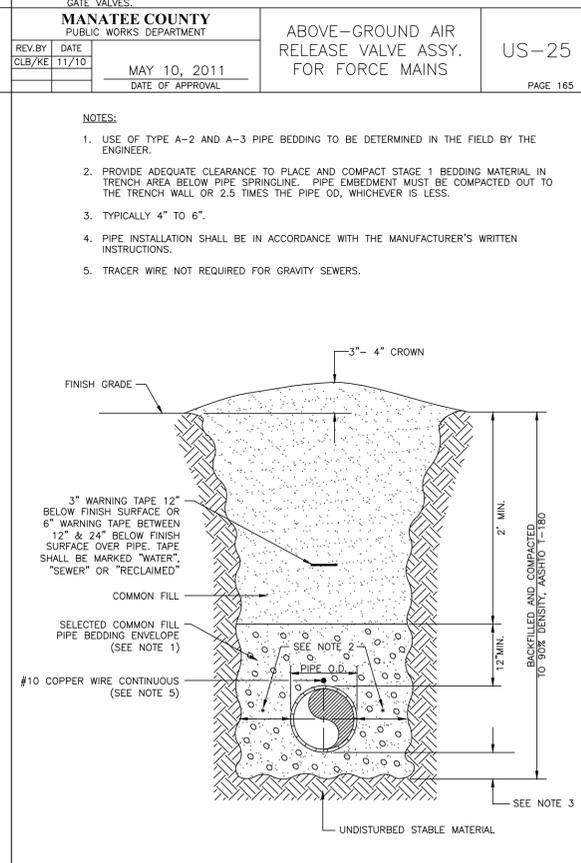

No.	REVISIONS	DATE	BY

**Kimley-Horn**  
 © 2017 KIMLEY-HORN AND ASSOCIATES, INC.  
 655 NORTH FRANKLIN STREET, SUITE 150, TAMPA, FL 33602  
 PHONE: 813-620-1460  
 WWW.KIMLEY-HORN.COM CA 00000696

**Manatee County Florida**  
**FORCE MAIN 11 REPLACEMENT**  
 MANATEE COUNTY  
 DATE: 10/24/2017  
 SCALE: AS SHOWN  
 DESIGNED BY: JWW  
 DRAWN BY: SAE  
 CHECKED BY: WWW

LICENSED PROFESSIONAL  
**W. WADE WOOD, P.E.**  
 FL LICENSE NUMBER: 69051  
 DATE: \_\_\_\_\_

**811** KNOW WHAT'S BELOW ALWAYS CALL 811 BEFORE YOU DIG  
 www.callsunshine.com

**GROUNDWATER / DEWATERING NOTE:**  
 THE PRESENCE OF GROUNDWATER SHOULD BE ANTICIPATED ON THIS PROJECT. CONTRACTOR'S BID SHALL INCLUDE CONSIDERATION FOR THIS ISSUE. WHEN PERFORMING GRADING OPERATIONS DURING PERIODS OF WET WEATHER, PROVIDE ADEQUATE DEWATERING, DRAINAGE AND GROUND WATER MANAGEMENT TO CONTROL MOISTURE OF SOILS.

SHEET NUMBER: **19**

This document, together with the concepts and designs presented herein, is intended only for the specific purpose and client for which it was prepared. Reuse of any information or design on this document without written authorization and adaptation by Kimley-Horn and Associates, Inc. shall be without liability to Kimley-Horn and Associates, Inc.

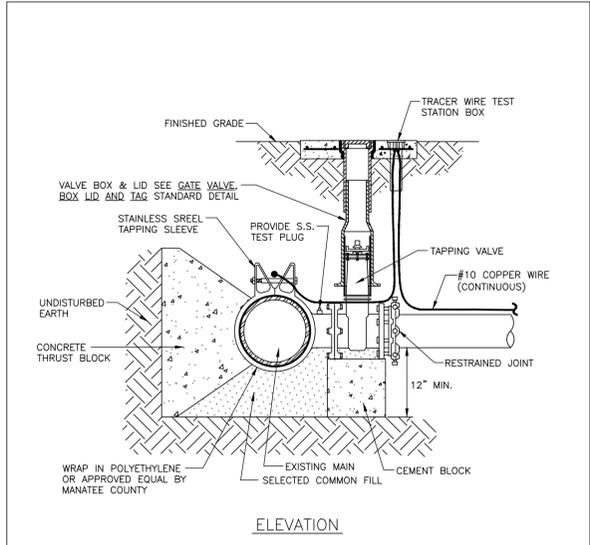

- NOTES:**
- PRIOR TO TAPPING, CONTRACTOR TO DEMONSTRATE 60 MINUTE HYDROSTATIC TEST OF THE TAPPING SLEEVE AND VALVE WITH NO LOSS OF 180 PSI PRESSURE FOR WATER AND RECLAIMED WATER OR 150 PSI FOR FORCE MAIN.
  - ALL FITTINGS TO BE WRAPPED WITH 20 MIL VISQUEEN AT THRUST BLOCK.
  - ALL TAPS ON CONCRETE WATER MAINS AND LARGER THAN 12" ARE TO BE MADE BY A MANATEE COUNTY APPROVED TAPPING COMPANY. ALL MATERIALS TO BE SUPPLIED BY THE CONTRACTOR.
  - ALL TAPS MUST BE OF A SMALLER SIZE THAN THE MAIN BEING TAPPED & PLACED NO CLOSER THAN 30" OR A DISTANCE EQUAL TO (1) MAIN PIPE DIAMETER PLUS (2) TAP PIPE DIAMETERS (WHICHEVER IS GREATER) FROM A JOINT OR FITTING.
  - CONTRACTOR TO SUPPLY A DRY HOLE FOR TAPPING CREW TO WORK IN AND A BACK-HOE TO LOWER TAPPING MACHINE INTO THE HOLE.
  - WHERE THRUST BLOCK NOT USED, RESTRAINED JOINTS MUST THEN EXTEND FROM THE FULL LENGTH SPECIFIED FOR TEES.
  - TRACER WIRE TEST STATION BOX IS REQUIRED AT CONNECTIONS TO EXISTING MAINS.

<b>MANATEE COUNTY</b> PUBLIC WORKS DEPARTMENT		TAPPING SLEEVE AND VALVE	UW-4
REV. BY	DATE		
CLB/KE	11/10	MAY 10, 2011	DATE OF APPROVAL
			PAGE 122

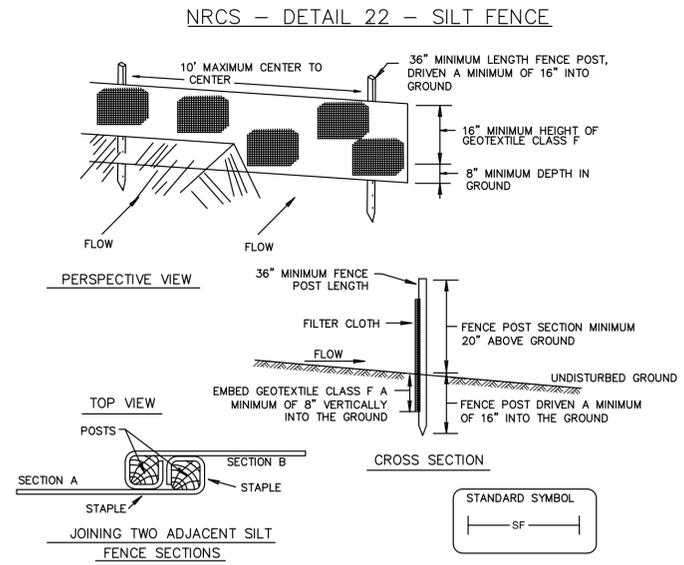

**SILT FENCE DESIGN CRITERIA**

SLOPE STEEPNESS	(MAXIMUM) SLOPE LENGTH	(MAXIMUM) SILT FENCE LENGTH
FLATTER THAN 50:1	UNLIMITED	UNLIMITED
50:1 TO 10:1	125 FEET	1000 FEET
10:1 TO 5:1	100 FEET	750 FEET
5:1 TO 3:1	60 FEET	500 FEET
3:1 TO 2:1	40 FEET	250 FEET
2:1 AND STEEPER	20 FEET	125 FEET

**NOTE:** IN AREAS OF LESS THAN 2% SLOPE AND SANDY SOILS (USDA GENERAL CLASSIFICATION SYSTEM, SOIL CLASS A) MAXIMUM SLOPE LENGTH AND SILT FENCE LENGTH WILL BE UNLIMITED. IN THESE AREAS A SILT FENCE MAY BE THE ONLY PERIMETER CONTROL REQUIRED.

- CONSTRUCTION SPECIFICATIONS**
- FENCE POSTS SHALL BE A MINIMUM OF 36" LONG DRIVEN 16" MINIMUM INTO THE GROUND. WOOD POSTS SHALL BE 1 1/2" X 1 1/2" SQUARE (MINIMUM) CUT, OR 1 3/4" DIAMETER (MINIMUM) ROUND AND SHALL BE OF SOUND QUALITY HARDWOOD. STEEL POSTS WILL BE STANDARD T OR U SECTION WEIGHING NOT LESS THAN 1.00 POUND PER LINEAR FOOT.
  - GEOTEXTILE SHALL BE FASTENED SECURELY TO EACH FENCE POST WITH WIRE TIES OR STAPLES AT TOP AND MID-SECTION AND SHALL MEET THE FOLLOWING REQUIREMENTS FOR GEOTEXTILE CLASS F:  

TENSILE STRENGTH	50 LBS/IN (MIN.)
TENSILE MODULUS	20 LBS/IN (MIN.)
FLOW RATE	0.3 GAL-FI/MINUTE (MAX.)
FILTERING EFFICIENCY	75% (MIN.)
  - WHERE ENDS OF GEOTEXTILE FABRIC COME TOGETHER, THEY SHALL BE OVERLAPPED, FOLDED AND STAPLED TO PREVENT SEDIMENT BYPASS.
  - SILT FENCE SHALL BE INSPECTED AFTER EACH RAINFALL EVENT AND MAINTAINED WHEN BULGES OCCUR OR WHEN SEDIMENT ACCUMULATION REACHED 50% OF THE FABRIC HEIGHT.

**TEMPORARY SEDIMENT FENCE (SF)**

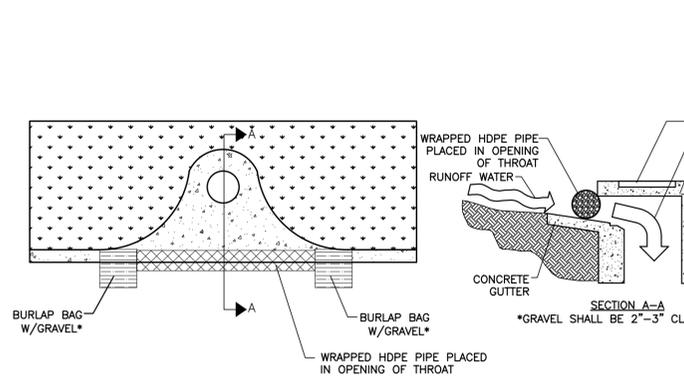

**SOCK DRAIN INLET SEDIMENT FILTER**

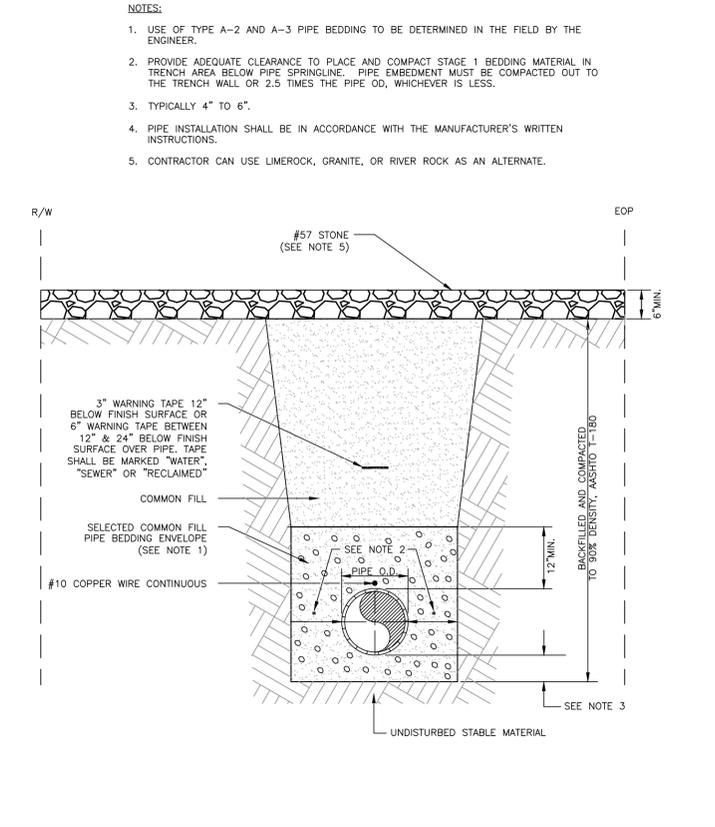

**Kimley Horn** **FORCE MAIN 11 DRIVEWAY RESTORATION DETAIL**

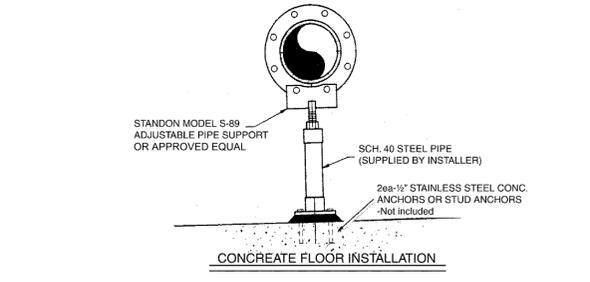

**FLANGE PIPE SUPPORT**

FLANGE SIZE	HOLE RADIUS	FLG PLATE	THRD STUD	BASE PLATE	EXTENSION PIPE REQ.	MINIMUM DIST. TO FLOOR
2"	2.375"	.250"	1" x 6"	4" x 6" x .25"	2" Sch. 40	7"
2.5"	2.75"	.250"	1" x 6"	4" x 6" x .25"	2" Sch. 40	7"
3"	3.00"	.250"	1" x 6"	4" x 6" x .25"	2" Sch. 40	7"
4"	3.75"	.250"	1" x 6"	4" x 6" x .25"	2" Sch. 40	7"
6"	4.75"	.250"	1" x 6"	4" x 6" x .25"	2" Sch. 40	7"
8"	5.87"	.250"	1" x 6"	4" x 6" x .25"	2" Sch. 40	7"
10"	7.125"	.250"	1" x 6"	4" x 6" x .25"	2" Sch. 40	7"
12"	8.50"	.250"	1" x 6"	4" x 6" x .25"	2" Sch. 40	7"
14"	9.375"	.375"	1 1/2" x 6"	8" x 8" x .5"	3" Sch. 40	9.5"
16"	9.625"	.375"	1 1/2" x 6"	8" x 8" x .5"	3" Sch. 40	9.5"
18"	11.375"	.375"	2" x 6"	8" x 8" x .5"	4" Sch. 40	10"
20"	12.50"	.375"	2" x 6"	8" x 8" x .5"	4" Sch. 40	10"
24"	14.75"	.375"	2" x 6"	8" x 8" x .5"	4" Sch. 40	10"

**FLANGE PIPE SUPPORT**

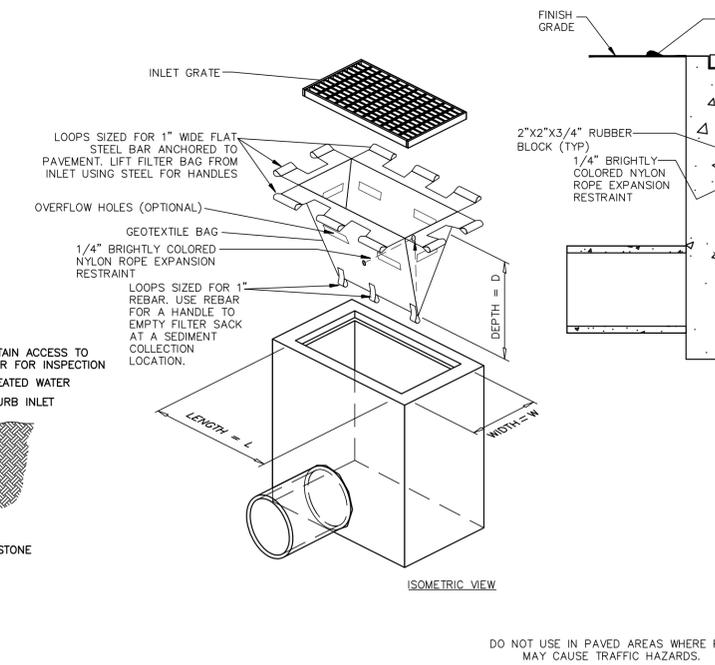

**FILTER SACKS (GRATED INLETS)**

**LOW TO MODERATE FLOW GEOTEXTILE FABRIC SPECIFICATION TABLE**

PROPERTIES	TEST METHOD	UNITS
GRAB TENSILE STRENGTH	ASTM D-4632	300 LBS
GRAB TENSILE ELONGATION	ASTM D-4632	20 %
PUNCTURE	ASTM D-4633	120 LBS
MULLEN BURST	ASTM D-3786	800 PSI
TRAPEZOID TEAR	ASTM D-4533	120 LBS
UV RESISTANCE	ASTM D-4355	80 %
APPARENT OPENING SIZE	ASTM D-4751	40 US SEIVE
FLOW RATE	ASTM D-4491	40 GAL./MIN./SQ FT
PERMITTIVITY	ASTM D-4491	0.55 SEC -1

**MODERATE TO HIGH FLOW GEOTEXTILE FABRIC SPECIFICATION TABLE**

PROPERTIES	TEST METHOD	UNITS
GRAB TENSILE STRENGTH	ASTM D-4632	265 LBS
GRAB TENSILE ELONGATION	ASTM D-4632	20 %
PUNCTURE	ASTM D-4633	135 LBS
MULLEN BURST	ASTM D-3786	420 PSI
TRAPEZOID TEAR	ASTM D-4533	45 LBS
UV RESISTANCE	ASTM D-4355	90 %
APPARENT OPENING SIZE	ASTM D-4751	20 US SEIVE
FLOW RATE	ASTM D-4491	200 GAL./MIN./SQ FT
PERMITTIVITY	ASTM D-4491	1.5 SEC -1

**GROUNDWATER / DEWATERING NOTE:**  
THE PRESENCE OF GROUNDWATER SHOULD BE ANTICIPATED ON THIS PROJECT. CONTRACTOR'S BID SHALL INCLUDE CONSIDERATION FOR THIS ISSUE. WHEN PERFORMING GRADING OPERATIONS DURING PERIODS OF WET WEATHER, PROVIDE ADEQUATE DEWATERING, DRAINAGE AND GROUND WATER MANAGEMENT TO CONTROL MOISTURE OF SOILS.

No.	REVISIONS	DATE	BY

**Kimley Horn**  
© 2017 KIMLEY-HORN AND ASSOCIATES, INC.  
655 NORTH FRANKLIN STREET, SUITE 150, TAMPA, FL 33602  
PHONE: 813-620-1460  
WWW.KIMLEY-HORN.COM CA 00000696

**Manatee County Florida**  
**FORCE MAIN 11 REPLACEMENT**  
KHA PROJECT 148400019  
DATE 10/24/2017  
SCALE AS SHOWN  
DESIGNED BY JWW  
DRAWN BY SAE  
CHECKED BY WWW MANATEE COUNTY

LICENSED PROFESSIONAL  
W. WADE WOOD, P.E.  
FL LICENSE NUMBER 69051  
FL DATE:

**CONSTRUCTION DETAILS**  
SHEET NUMBER 20



This document, together with the concepts and designs presented herein, is an instrument of service, is intended only for the specific purpose and client for which it was prepared. Reuse of any improper reference on this document without written authorization and adaptation by Kimley-Horn and Associates, Inc. shall be without liability to Kimley-Horn and Associates, Inc.

**LANDSCAPE SPECIFICATIONS**

**1. SCOPE OF WORK**

- 1.1. THE WORK CONSISTS OF: FURNISHING ALL LABOR, MATERIALS, EQUIPMENT, TOOLS, TRANSPORTATION, AND ANY OTHER APPURTENANCES NECESSARY FOR THE COMPLETION OF THIS PROJECT AS SHOWN ON THESE PLANS.
- 1.2. WORK SHALL INCLUDE MAINTENANCE AND WATERING OF ALL CONTRACT PLANTING AREAS UNTIL CERTIFICATION OF ACCEPTANCE BY THE OWNER.
- 1.3. WORK SHALL BE COORDINATED WITH OTHER TRADES TO PREVENT CONFLICTS.
- 1.4. THE SCOPE OF WORK SHALL CONSIST OF:

**2. PROTECTION OF EXISTING AND PROPOSED SITE ELEMENTS**

- 2.1. ALL EXISTING SITE ITEMS, ALREADY COMPLETED OR ESTABLISHED AND DESIGNATED TO REMAIN SHALL BE PROTECTED FROM DAMAGE BY THE CONTRACTOR UNLESS OTHERWISE SPECIFIED. ALL DAMAGE RESULTING FROM THE CONTRACTOR'S WORK SHALL BE REPAIRED OR REPLACED TO THE SATISFACTION OF THE OWNER, AT NO COST TO THE OWNER.
- 2.2. THE CONTRACTOR SHALL BE RESPONSIBLE FOR MAINTAINING ALL NECESSARY BMP DEVICES THROUGHOUT THE DURATION OF ALL CONSTRUCTION ACTIVITIES.
- 2.3. WHERE APPLICABLE, THE CONTRACTOR SHALL SUBMIT A DETAILED PROJECT SPECIFIC WORK ZONE TRAFFIC CONTROL PLAN IN ACCORDANCE WITH THE APPROPRIATE REGULATORY AGENCY STANDARDS UNLESS THE WORK REQUIRES NOTHING MORE THAN A DIRECT APPLICATION OF FDOT DESIGN STANDARDS, INDEX 600.
- 2.4. THE CONTRACTOR SHALL BE RESPONSIBLE FOR LOCATING ALL UTILITIES, WHETHER PUBLIC OR PRIVATE, PRIOR TO CONSTRUCTION ACTIVITIES. THE INFORMATION AND DATA SHOWN WITH RESPECT TO EXISTING UTILITIES IS APPROXIMATE. THE OWNER AND DESIGN PROFESSIONAL SHALL NOT BE RESPONSIBLE FOR THE ACCURACY AND COMPLETENESS OF ANY SUCH INFORMATION OR DATA. THE CONTRACTOR SHALL HAVE FULL RESPONSIBILITY FOR: REVIEWING AND CHECKING ALL SUCH INFORMATION AND DATA; LOCATING ALL UTILITIES PRIOR TO CONSTRUCTION; THE SAFETY AND PROTECTION THEREOF; REPAIRING ANY DAMAGE RESULTING FROM THE WORK. THE COST OF ALL WILL BE CONSIDERED AS HAVING BEEN INCLUDED IN THE CONTRACT PRICE. THE CONTRACTOR SHALL NOTIFY ANY AFFECTED UTILITY COMPANIES OR AGENCIES IN WRITING AT LEAST 48 HOURS PRIOR TO BEGINNING CONSTRUCTION. THE CONTRACTOR SHALL NOTIFY THE LANDSCAPE ARCHITECT IN WRITING WHEN ANY CONFLICT BETWEEN UTILITIES AND THESE PLANS EXIST PRIOR TO PLANTING.
- 2.5. THE CONTRACTOR SHALL BE RESPONSIBLE FOR ALL UNAUTHORIZED CUTTING OR DAMAGE TO PLANT MATERIAL EXISTING OR OTHERWISE. THIS SHALL INCLUDE COMPACTION AND SPILLING OF ANY DELETERIOUS MATERIALS WITHIN THE DRIP-LINE OF EXISTING TREES TO REMAIN, PLANT MATERIAL KILLED OR DAMAGED THAT IS MISSHAPEN AND/OR UNSIGHTLY SHALL BE REPLACED WITH LIKE SIZE AND KIND TO THE SATISFACTION OF THE OWNER OR REGULATORY AGENCY AT THE COST TO THE CONTRACTOR.

**3. SUBMITTALS**

- 3.1. MATERIAL SAMPLES LISTED BELOW SHALL BE SUBMITTED FOR APPROVAL, ON SITE OR AS DETERMINED BY THE OWNER. UPON APPROVAL, DELIVERY OF MATERIALS MAY COMMENCE.
 

MATERIAL	SAMPLE SIZE
MULCH	ONE (1) GALLON PLASTIC BAG
SOIL MIXTURE	ONE (1) GALLON PLASTIC BAG
PLANTS	ONE (1) OF EACH VARIETY (OR TAGGED IN NURSERY)
- 3.2. CONTRACTOR TO SUBMIT TESTING RESULTS OF SOIL MIXTURE AS PER SECTION 6 BELOW.

**4. PLANT MATERIALS**

- 4.1. ALL PLANT MATERIAL SHALL CONFORM TO THE SPECIFICATIONS INDICATED ON THE DRAWINGS AND SHALL BE IN ACCORDANCE WITH GRADES AND STANDARDS FOR NURSERY PLANTS, LATEST EDITION, PUBLISHED BY THE FLORIDA DEPARTMENT OF AGRICULTURE AND CONSUMER SERVICES. ALL PLANTS SHALL BE FLORIDA GRADE NO. 1 OR BETTER AS DETERMINED BY THE FLORIDA DIVISION OF PLANT INDUSTRY. ALL MATERIALS SHALL BE SUBJECT TO APPROVAL BY THE OWNER OR OWNER'S REPRESENTATIVE. NO SUBSTITUTIONS SHALL BE MADE WITHOUT WRITTEN PERMISSION FROM THE LANDSCAPE ARCHITECT AND OWNER.
- 4.2. ALL TREE SPECIES INSTALLED SHALL BE MATCHED IN SIZE AND SHAPE UNLESS NOTED OTHERWISE.
- 4.3. PLANTS SHALL BE SUBJECT TO INSPECTION AND APPROVAL AT THE PLACE OF GROWTH, UPON DELIVERY TO THE SITE, DURING PROGRESS OF THE WORK AND/OR AFTER COMPLETION. REJECTED PLANTS SHALL BE REMOVED AND REPLACED IMMEDIATELY.

**5. DIGGING AND HANDLING**

- 5.1. PROTECT ROOTS OR ROOT BALLS OF PLANTS AT ALL TIMES FROM SUN, DRYING WINDS, WATER AND FREEZING, AS NECESSARY UNTIL PLANTING. NO PLANT MATERIAL SHALL BE HANDLED BY STEMS.

**6. SOIL MIXTURE (PLANTING MEDIUM, PLANTING MIX, TOPSOIL MIX)**

- 6.1. CONTRACTOR SHALL TEST EXISTING SOIL AND AMEND AS NECESSARY IN ACCORDANCE WITH THE GUIDELINES BELOW:
- 6.2. SOIL MIXTURE (PLANTING MEDIUM FOR PLANT PITS) SHALL CONSIST OF TWO PARTS OF TOPSOIL AND ONE PART SAND, AS DESCRIBED BELOW. CONTRACTOR TO SUBMIT SAMPLES AND PH TESTING RESULTS OF SOIL MIXTURE FOR OWNER'S REPRESENTATIVE APPROVAL PRIOR TO PLANT INSTALLATION OPERATIONS COMMENCE.
- 6.3. TOPSOIL FOR USE IN PREPARING SOIL MIXTURE FOR BACKFILLING PLANT PITS SHALL BE FERTILE, FRIABLE, AND OF A LOAMY CHARACTER; REASONABLY FREE OF SUBSOIL, CLAY LUMPS, BRUSH WEEDS AND OTHER LITTER; FREE OF ROOTS, STUMPS, STONES LARGER THAN 2" IN ANY DIRECTION, AND OTHER EXTRANEOUS OR TOXIC MATTER HARMFUL TO PLANT GROWTH. IT SHALL CONTAIN THREE (3) TO FIVE (5) PERCENT DECOMPOSED ORGANIC MATTER AND HAVE A PH BETWEEN 5.5 AND 7.0.
- 6.4. SAND SHALL BE COARSE, CLEAN, WELL-DRAINING, NATIVE SAND.
- 6.5. TREES SHALL BE PLANTED IN THE EXISTING NATIVE SOIL ON SITE, UNLESS DETERMINED TO BE UNSUITABLE - AT WHICH POINT THE CONTRACTOR SHALL CONTACT OWNER'S REPRESENTATIVE TO DISCUSS ALTERNATE RECOMMENDATION PRIOR TO PLANTING.

**7. WATER**

- 7.1. CONTRACTOR SHALL PROVIDE WATER NECESSARY FOR PLANTING ESTABLISHMENT AND MAINTENANCE. WATER SHALL BE OF SATISFACTORY QUALITY TO SUSTAIN ADEQUATE PLANT GROWTH AND SHALL NOT CONTAIN HARMFUL, NATURAL OR MAN-MADE ELEMENTS DETRIMENTAL TO PLANTS.
- 7.2. WATERING/IRRIGATION RESTRICTIONS MAY APPLY - REFER TO PROPERTY'S JURISDICTIONAL AUTHORITY.

**8. FERTILIZER**

- 8.1. CONTRACTOR SHALL PROVIDE FERTILIZER APPLICATION SCHEDULE TO OWNER, AS APPLICABLE TO SOIL TYPE, PLANT INSTALLATION TYPE, AND SITE'S PROPOSED USE. SUGGESTED FERTILIZER TYPES SHALL BE ORGANIC OR OTHERWISE NATURALLY-DERIVED.
- 8.2. FERTILIZER RESTRICTIONS MAY APPLY - REFER TO PROPERTY'S JURISDICTIONAL AUTHORITY.

**9. MULCH**

- 9.1. MULCH MATERIAL SHALL BE MOISTENED AT THE TIME OF APPLICATION TO PREVENT WIND DISPLACEMENT, AND APPLIED AT A MINIMUM DEPTH OF THREE (3) INCHES. CONTRACTOR SHALL CLEAR MULCH FROM WITHIN A SIX (6) INCH RADIUS AROUND TRUNK / STEM FLARE. MULCH SHALL BE "FLORIMULCH", EUCALYPTUS MULCH, OR SIMILAR SUSTAINABLY HARVESTED MULCH UNLESS SPECIFIED OTHERWISE.
- 9.2. PROVIDE A THREE (3) INCH MINIMUM LAYER OF SPECIFIED MULCH OVER THE ENTIRE AREA OF EACH PLANTING BED AND TREE RING (SIX (6) FOOT DIAMETER MINIMUM).

**10. CONTAINER GROWN STOCK**

- 10.1. CONTAINER GROWN PLANTS SHALL HAVE BEEN GROWN IN IT'S CONTAINER SUFFICIENTLY LONG ENOUGH FOR THE NEW FIBROUS ROOTS TO HAVE DEVELOPED SO THAT THE ROOT MASS WILL RETAIN ITS SHAPE AND HOLD TOGETHER WHEN REMOVED FROM THE CONTAINER.
- 10.2. INSUFFICIENT OR POORLY STRUCTURED ROOT SYSTEMS ARE NOT ACCEPTABLE AND WILL BE REJECTED.
- 10.3. ROOTS PLUS GROWER (RPG) PRODUCTS SHALL BE USED WHERE SPECIFIED.

**11. MATERIALS LIST**

- 11.1. ALL QUANTITIES ARE PROVIDED FOR CONVENIENCE ONLY. CONTRACTOR SHALL CONFIRM ALL QUANTITIES PER PLAN PRIOR TO BIDDING AND CONSTRUCTION.

**12. FINE GRADING**

- 12.1. CONTRACTOR SHALL BE RESPONSIBLE FOR FINE GRADING WHICH CONSISTS OF FINAL FINISHED GRADING (INCLUDING ADDITIONAL SOIL MIXTURE AS NEEDED) FOR LAWN AND PLANTING AREAS THAT HAVE BEEN ROUGH GRADED BY OTHERS. FINISH GRADE SHALL ACCOUNT FOR THICKNESS OF SOD AND/OR MULCH DEPTH.
- 12.2. ALL PLANTING AREAS SHALL BE GRADED AND MAINTAINED FOR POSITIVE DRAINAGE TO SURFACE/SUBSURFACE STORM DRAIN SYSTEMS. AREAS ADJACENT TO BUILDINGS SHALL SLOPE AWAY FROM THE BUILDINGS. REFER TO CIVIL ENGINEER'S PLANS FOR FINAL GRADES, IF APPLICABLE.

**13. PLANTING PROCEDURES**

- 13.1. THE CONTRACTOR SHALL CLEAN WORK AND SURROUNDING AREAS OF ALL RUBBISH OR OBJECTIONABLE MATTER DAILY. ALL MORTAR, CEMENT, AND TOXIC MATERIAL SHALL BE REMOVED FROM THE SURFACE OF ALL PLANT BEDS. THESE MATERIALS SHALL NOT BE MIXED WITH THE SOIL. SHOULD THE CONTRACTOR FIND SUCH SOIL CONDITIONS BENEATH THE SOIL WHICH WILL IN ANY WAY ADVERSELY AFFECT THE PLANT GROWTH, HE SHALL IMMEDIATELY CALL IT TO THE ATTENTION OF THE OWNER'S REPRESENTATIVE.
- 13.2. LOCATE, MAINTAIN AND PROTECT ALL UTILITIES ABOVE AND BELOW GROUND. CALL SUNSHINE STATE ONE CALL OF FLORIDA, INC. (811) TO LOCATE UTILITIES AT LEAST 48 HOURS PRIOR TO CONSTRUCTION.
- 13.3. CONTRACTOR SHALL NOTIFY LANDSCAPE ARCHITECT IN WRITING IMMEDIATELY IF CONFLICT(S) EXIST WITH PROPOSED TREE LOCATIONS AND EXISTING OVERHEAD POWER LINES IN ACCORDANCE WITH SETBACK REQUIREMENTS OF FPL'S "RIGHT TREE, RIGHT PLACE" PROGRAM. CONSULT THE UNIVERSITY OF FLORIDA'S "TREES AND POWER LINE WEBSITE FOR TREE SIZE CATEGORIES.
- 13.4. CONTRACTOR SHALL NOTIFY LANDSCAPE ARCHITECT IN WRITING IMMEDIATELY IF CONFLICT(S) EXIST WITH PROPOSED TREE LOCATIONS AND EXISTING / PROPOSED LIGHT POLES. TREES INSTALLED IN CONFLICT WITH LIGHT POLES ARE SUBJECT TO RELOCATION AT THE EXPENSE OF THE CONTRACTOR.
- 13.5. CONTRACTOR IS RESPONSIBLE TO REMOVE ALL EXISTING AND IMPORTED DELETERIOUS MATERIAL AND SUB-BASE FROM ALL LANDSCAPE PLANTING AREAS TO A MINIMUM DEPTH OF 36" OR TO NATIVE SOIL. CONTRACTOR IS RESPONSIBLE TO BACKFILL THESE PLANTING AREAS TO ROUGH FINISHED GRADE AS NEEDED WITH CLEAN SOIL MIXTURE.
- 13.6. FURNISH NURSERY'S CERTIFICATE OF COMPLIANCE WITH ALL APPLICABLE REQUIREMENTS. COMPLY WITH APPLICABLE FEDERAL, STATE, COUNTY, AND LOCAL REGULATIONS GOVERNING LANDSCAPE MATERIALS AND WORK.
- 13.7. EXCAVATE ALL PLANTING PITS IN ACCORDANCE WITH LANDSCAPE DETAILS PROVIDED. TEST ALL TREE PITS WITH WATER BEFORE PLANTING TO ASSURE PROPER DRAINAGE PERCOLATION IS AVAILABLE. IF POOR DRAINAGE EXISTS, CONTRACTOR SHALL NOTIFY LANDSCAPE ARCHITECT IMMEDIATELY IN WRITING. NO ALLOWANCE WILL BE MADE FOR LOST PLANTS DUE TO IMPROPER DRAINAGE. CONTRACTOR SHALL ENSURE ELIMINATION OF ALL AIR POCKETS AROUND ROOTS.
- 13.8. TREES AND SHRUBS SHALL BE SET STRAIGHT AT AN ELEVATION THAT, AFTER SETTLEMENT, THE PLANT CROWN WILL STAND ONE (1) TO TWO (2) INCHES ABOVE GRADE. EACH PLANT SHALL BE SET IN THE CENTER OF THE PIT. PLANTING SOIL MIXTURE SHALL BE BACK FILLED, THOROUGHLY TAMPED AROUND THE BALL, AND SETTLED BY WATER (AFTER TAMPING).
- 13.9. SHRUBS AND GROUND COVER PLANTS SHALL BE SPACED IN ACCORDANCE WITH THE DRAWINGS, LANDSCAPE DETAILS AND AS INDICATED ON THE PLANT LIST.
- 13.10. FAILURE TO FOLLOW THE ABOVE PLANTING PROCEDURE SHALL MAKE THE CORRECTIVE MEASURES THE RESPONSIBILITY OF THE CONTRACTOR.

**14. LAWN SODDING**

- 14.1. THE WORK CONSISTS OF LAWN BED PREPARATION, SOIL PREPARATION, AND SODDING NECESSARY TO PRODUCE A TURF GRASS LAWN ACCEPTABLE TO THE OWNER.
- 14.2. ALL AREAS THAT ARE TO BE SODDED SHALL BE CLEARED OF ANY ROUGH GRASS, WEEDS, AND DEBRIS TO A MINIMUM DEPTH OF THREE (3) INCHES. PROVIDE ONE (1) INCH OF TOPSOIL ACROSS ENTIRE LAWN BED AND MIX THOROUGHLY INTO TOP FOUR (4) INCHES OF SOIL TO BRING THE GROUND TO AN EVEN GRADE. THE ENTIRE SURFACE SHALL BE ROLLED WITH A ROLLER WEIGHING NOT MORE THAN ONE-HUNDRED (100) POUNDS PER FOOT OF WIDTH. DURING THE ROLLING, ALL DEPRESSIONS CAUSED BY SETTLEMENT SHALL BE FILLED WITH ADDITIONAL TOPSOIL AND THE SURFACE SHALL BE REGRADED AND ROLLED UNTIL PRESENTING A SMOOTH AND EVEN FINISH TO THE REQUIRED GRADE.
- 14.3. HAND RAKE LAWN BED UNTIL ALL BUMPS AND DEPRESSIONS ARE REMOVED. WET PREPARED AREA THOROUGHLY.
- 14.4. THE CONTRACTOR SHALL SOD ALL AREAS THAT ARE NOT PAVED OR PLANTED AS DESIGNATED ON THE DRAWINGS WITHIN THE CONTRACT LIMITS, UNLESS SPECIFICALLY NOTED OTHERWISE.
- 14.5. HAND THE SOD SHALL BE CERTIFIED TO MEET FLORIDA STATE PLANT BOARD SPECIFICATIONS, ABSOLUTELY TRUE TO VARIETAL TYPE, AND FREE FROM WEEDS, FUNGUS, INSECTS AND DISEASE OF ANY KIND.
- 14.6. SOD PANELS SHALL BE LAID TIGHTLY TOGETHER SO AS TO MAKE A SOLID SODDED LAWN AREA. SOD SHALL BE LAID UNIFORMLY AGAINST THE EDGES OF ALL CURBS AND OTHER HARDSCAPE ELEMENTS, PAVED AND PLANTED AREAS.
- 14.7. IMMEDIATELY FOLLOWING SOD LAYING, THE LAWN AREAS SHALL BE ROLLED WITH A LAWN ROLLER AND THEN THOROUGHLY IRRIGATED.
- 14.8. IF, IN THE OPINION OF THE OWNER, TOP-DRESSING IS NECESSARY AFTER ROLLING TO FILL THE VOIDS BETWEEN THE SOD PANELS AND TO EVEN OUT INCONSISTENCIES IN THE SOD, CLEAN SAND, AS APPROVED BY THE OWNER'S REPRESENTATIVE, SHALL BE UNIFORMLY SPREAD OVER THE ENTIRE SURFACE OF THE SOD AND THOROUGHLY WATERED IN. FERTILIZE INSTALLED SOD AS ALLOWED BY PROPERTY'S JURISDICTIONAL AUTHORITY.
- 14.9. DURING DELIVERY, PRIOR TO, AND DURING THE PLANTING OF THE LAWN AREAS, THE SOD PANELS SHALL AT ALL TIMES BE PROTECTED FROM EXCESSIVE DRYING AND UNNECESSARY EXPOSURE OF THE ROOTS TO THE SUN. ALL SOD SHALL BE STACKED SO AS NOT TO BE DAMAGED BY EXCESSIVE HEAT AND MOISTURE.
- 14.10. WITHIN THE CONTRACT LIMITS, THE CONTRACTOR SHALL PRODUCE AND MAINTAIN A DENSE, WELL ESTABLISHED LAWN. THE CONTRACTOR SHALL BE RESPONSIBLE FOR THE REPAIR AND RE-SODDING OF ALL ERODED, SUNKEN OR BARE SPOTS UNTIL CERTIFICATION OF ACCEPTANCE BY THE OWNER'S REPRESENTATIVE. REPAIRED SODDING SHALL BE ACCOMPLISHED AS IN THE ORIGINAL WORK (INCLUDING REGRADED IF NECESSARY).

**15. CLEANUP**

- 15.1. UPON COMPLETION OF ALL PLANTING WORK AND BEFORE FINAL ACCEPTANCE, THE CONTRACTOR SHALL REMOVE ALL MATERIAL, EQUIPMENT, AND DEBRIS RESULTING FROM HIS WORK. ALL PAVED AREAS SHALL BE CLEANED AND THE SITE LEFT IN A NEAT AND ACCEPTABLE CONDITION AS APPROVED BY THE OWNER'S REPRESENTATIVE.

**16. PLANT MATERIAL MAINTENANCE**

- 16.1. ALL PLANT MATERIAL SHALL BE MAINTAINED BY WATERING, CULTIVATING, SPRAYING, AND ALL OTHER OPERATIONS (SUCH AS RE-STAKING OR REPAIRING GUY SUPPORTS) AS NECESSARY TO INSURE HEALTHY AND VIGOROUS GROWING CONDITIONS BY THE CONTRACTOR UPON DELIVERING TO THE SITE AND UNTIL FINAL ACCEPTANCE OF WORK.

**17. FINAL INSPECTION AND ACCEPTANCE OF WORK**

- 17.1. ALL PLANT BEDS SHALL BE KEPT FREE OF NOXIOUS WEEDS UNTIL FINAL ACCEPTANCE OF WORK. PRIOR TO FINAL INSPECTION, TREAT ALL PLANTING BEDS WITH AN APPROVED PRE-EMERGENT HERBICIDE PER MANUFACTURER RECOMMENDATIONS. (AS ALLOWED BY JURISDICTIONAL AUTHORITY)
- 17.2. CONTRACTOR TO PROVIDE WATERING/IRRIGATION SCHEDULE FOR ALL PLANT MATERIAL TO OWNER. OBSERVE ALL APPLICABLE WATERING RESTRICTIONS AS SET FORTH BY THE PROPERTY'S JURISDICTIONAL AUTHORITY.
- 17.3. UPON COMPLETION OF ALL WORK, A FINAL INSPECTION SHALL BE PERFORMED BY THE OWNER AND/OR OWNER'S REPRESENTATIVE. ALL PLANTING, CONSTRUCTION AND ALL OTHER INCIDENTAL WORK PERTAINING TO THIS CONTRACT SHALL BE INSPECTED FOR COMPLIANCE WITH THE CONTRACT DOCUMENTS. ANY ITEMS FOUND TO NOT BE IN COMPLIANCE SHALL BE CORRECTED AT THE COST OF THE CONTRACTOR.

**18. WARRANTY**

- 18.1. THE LIFE AND SATISFACTORY CONDITION OF ALL PLANT MATERIAL INSTALLED BY THE LANDSCAPE CONTRACTOR SHALL BE WARRANTED BY THE CONTRACTOR FOR A MINIMUM OF ONE (1) CALENDAR YEAR COMMENCING AT THE TIME OF CERTIFICATION AND ACCEPTANCE OF THE WORK BY THE OWNER AND/OR OWNER'S REPRESENTATIVE.
- 18.2. ANY PLANT NOT FOUND IN A HEALTHY GROWING CONDITION THROUGHOUT THE WARRANTY PERIOD SHALL BE REMOVED FROM THE SITE AND REPLACED AS SOON AS WEATHER CONDITIONS PERMIT. ALL REPLACEMENTS SHALL BE PLANTS OF THE SAME KIND AND SIZE AS SPECIFIED IN THE PLANT LIST. THEY SHALL BE FURNISHED, PLANTED AND MULCHED AS SPECIFIED AT NO ADDITIONAL COST TO THE OWNER. ANY REPLACED PLANT MATERIAL SHALL BE SUBJECT TO A NEW ONE (1) YEAR WARRANTY.
- 18.3. IN THE EVENT THE OWNER DOES NOT CONTRACT WITH THE CONTRACTOR FOR LANDSCAPE AND IRRIGATION MAINTENANCE, THE CONTRACTOR SHOULD VISIT THE PROJECT SITE PERIODICALLY DURING THE ONE (1) YEAR WARRANTY PERIOD TO EVALUATE MAINTENANCE PROCEDURES BEING PERFORMED BY THE OWNER. CONTRACTOR SHALL NOTIFY THE OWNER IN WRITING OF MAINTENANCE PROCEDURES OR CONDITIONS WHICH THREATEN VIGOROUS AND HEALTHY PLANT GROWTH.

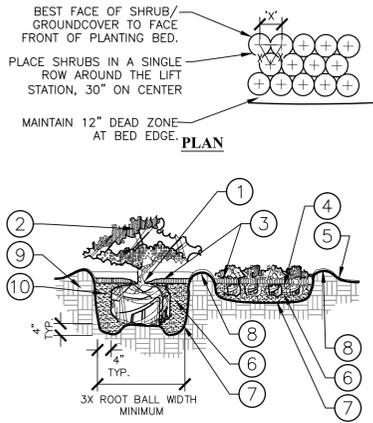

- ① TOP OF SHRUB ROOTBALLS TO BE PLANTED 1" - 2" HIGH WITH SOIL MOUNDING UP TO THE TOP OF ROOTBALL.
- ② PRUNE ALL SHRUBS TO ACHIEVE A UNIFORM MASS/HEIGHT.
- ③ 3" MULCH LAYER AS SPECIFIED.
- ④ EXCAVATE ENTIRE BED SPECIFIED FOR GROUNDCOVER BED.
- ⑤ FINISHED GRADE.
- ⑥ PREPARED PLANTING SOIL AS SPECIFIED. (SEE LANDSCAPE NOTES) NOTE: WHEN GROUND-COVERS AND SHRUBS USED IN MASSES, ENTIRE BED TO BE AMENDED WITH PLANTING SOIL MIX AS SPECIFIED.
- ⑦ SCARIFY OF PLANTING PIT SIDES AND BOTTOM.
- ⑧ 4" HIGH BERM FIRMLY COMPACTED.
- ⑨ UNDISTURBED NATIVE SOIL.
- ⑩ FERTILIZER TABLETS (MAX 3" DEEP)

**NOTES:**

- A. CONTRACTOR SHALL ASSURE PERCOLATION OF ALL PLANTING PITS PRIOR TO INSTALLATION.
- B. WHEN SHRUBS ARE PRUNED IN MASSES, PRUNE ALL SHRUBS TO ACHIEVE UNIFORM MASS / HEIGHT.
- C. ALL SHRUBS AND GROUNDCOVERS SHALL BE PLUMB VERTICALLY, UNLESS OTHERWISE DIRECTED BY OWNERS REPRESENTATIVE.
- D. PETITE PINK OLEANDER SHALL HAVE A SIZE OF 7 GALLONS AND A MINIMUM HEIGHT OF 36".

**PETITE PINK OLEANDER (NERIUM OLEANDER "PETITE") PLANTING**

**GROUNDWATER / DEWATERING NOTE:**  
 THE PRESENCE OF GROUNDWATER SHOULD BE ANTICIPATED ON THIS PROJECT. CONTRACTOR'S BID SHALL INCLUDE CONSIDERATION FOR THIS ISSUE. WHEN PERFORMING GRADING OPERATIONS DURING PERIODS OF WET WEATHER, PROVIDE ADEQUATE DEWATERING, DRAINAGE AND GROUND WATER MANAGEMENT TO CONTROL MOISTURE OF SOILS.



No.	REVISIONS	DATE	BY

**Kimley»Horn**

© 2017 KIMLEY-HORN AND ASSOCIATES, INC.  
 655 NORTH FRANKLIN STREET, SUITE 150, TAMPA, FL 33602  
 PHONE: 813-620-1460  
 WWW.KIMLEY-HORN.COM CA 00000696

KHA PROJECT 148400019  
 DATE 10/24/2017  
 SCALE AS SHOWN  
 DESIGNED BY JWW  
 DRAWN BY SAE  
 CHECKED BY WWW

**Manatee County FLORIDA**

**FORCE MAIN 11 REPLACEMENT**

MANATEE COUNTY

LICENSED PROFESSIONAL

W. WADE WOOD, P.E.

FL LICENSE NUMBER 69051

FL DATE:

**CONSTRUCTION DETAILS**