



DEPARTMENT OF THE ARMY  
CORPS OF ENGINEERS, JACKSONVILLE DISTRICT  
701 SAN MARCO BOULEVARD  
JACKSONVILLE, FLORIDA 32232-0019

November 17, 2021

Regulatory Division  
West Permits Branch  
Tampa Section  
SAJ-2021-02516(NW/GP-JLC)

Charlie Hunsicker, Director  
Manatee County Parks and Natural Resources  
5502 33<sup>rd</sup> Ave Drive West  
Bradenton, FL 34209  
Sent via email: charlie.hunsicker@mymanatee.org

Dear Mr. Hunsicker:

The U.S. Army Corps of Engineers (Corps) has completed the review of your application for a Department of the Army permit received on July 22, 2021. Your application was assigned file number SAJ-2021-02516. A review of the information and drawings provided indicates that the proposed work would result in the following: discharge 19 cubic yards of fill material over 0.025 acre of canal bottom and regrade 12 cubic yards of sediment over 0.007 acre of canal bottom for the repair and reconfiguration of an existing boat ramp; construct a 5.5 foot wide by 56 foot long wood dock extension to the existing L-shaped dock; and install two mooring piles along the seawall east of the eastern dock. The activities subject to this permit are authorized pursuant to authorities under Section 10 of the Rivers and Harbors Act of 1899 (33 U.S.C. § 403), and Section 404 of the Clean Water Act (33 U.S.C. § 1344). The project is located in estuarine waters in a canal tributary to the Manatee River at the Highland Shores Boat Ramp facility at 353 Shore Drive, Ellenton, Manatee County, Florida 34222 (27.514978°, -82.533481°).

The aspect of your project involving the repair and reconfiguration of the boat ramp, as depicted on the attached drawings, is authorized by Nationwide Permit (NWP) 36, which became effective on March 19, 2017 (82 FR 1860, January 6, 2017). **This verification is valid until March 18, 2022.** In order for this NWP authorization to be valid, you must ensure that the work is performed in accordance with the NWP General Conditions and the Jacksonville District Regional Conditions, and the General and Project-Specific Special Conditions listed below. Furthermore, if you commence or are under contract to commence this activity before the date that the relevant NWP is modified or revoked, you will have 12 months from the date of the modification or revocation of the NWP to complete the activity under the present terms and conditions of this NWP.

You may access the U.S. Army Corps of Engineers' (Corps) Jacksonville District's Regulatory Source Book web page for links to view NWP information at: <https://www.saj.usace.army.mil/Missions/Regulatory/Source-Book/>. Please be aware this Internet address is case sensitive and should be entered as it appears above. Once there, select "Source Book" and then select "Nationwide Permits." These files contain the description of the Nationwide Permit authorization, the Nationwide Permit general conditions, and the regional conditions, which apply specifically to this NWP verification. In addition, project-specific conditions are included with this verification.

The aspect of your project involving the dock extension and mooring pile installation, as depicted on the attached drawings, is authorized by Regional General Permit (RGP) SAJ-33 and its subsequent modifications, if applicable. **This RGP authorization is valid until July 24, 2023.** Please access the Corps' Jacksonville District Regulatory Division Source Book webpage to view the special and general conditions for SAJ-33, which apply specifically to this authorization. The Internet URL address is: <https://www.saj.usace.army.mil/Missions/Regulatory/Source-Book/>. Please be aware this Internet address is case sensitive and should be entered as it appears above. Once there, select "Source Book" and then select "General Permits." Then you will need to select the specific SAJ permit noted above.

### **General Conditions:**

1. The time limit for completing the work authorized ends on the dates specified in the paragraphs above.
2. You must maintain the activity authorized by this permit in good condition and in conformance with the terms and conditions of this permit. You are not relieved of this requirement if you abandon the permitted activity, although you may make a good faith transfer to a third party in compliance with General Condition 4 below. Should you wish to cease to maintain the authorized activity or should you desire to abandon it without a good faith transfer, you must obtain a modification of this permit from this office, which may require restoration of the area.
3. If you discover any previously unknown historic or archeological remains while accomplishing the activity authorized by this permit, you must immediately notify this office of what you have found. We will initiate the Federal and state coordination required to determine if the remains warrant a recovery effort or if the site is eligible for listing in the National Register of Historic Places.
4. If you sell the property associated with this permit you must obtain the signature of the new owner on the transfer form attached to this letter and forward a copy to this office to validate the transfer of this authorization.

5. If a conditioned water quality certification has been issued for your project, you must comply with the conditions specified in the certification as special conditions to this permit. For your convenience, a copy of the certification is attached if it contains such conditions.

6. You must allow a representative from this office to inspect the authorized activity at any time deemed necessary to ensure that it is being or has been accomplished in accordance with the terms and conditions of your permit.

**Project Specific Special Conditions:**

The following project specific special conditions are included with this verification:

1. **Reporting Address:** The Permittee shall submit all reports, notifications, documentation and correspondence required by the general and special conditions of this permit to the following address:

- a) For standard mail: U.S. Army Corps of Engineers, Regulatory Division, Special Projects and Enforcement Branch, 10117 Princess Palm Avenue, Suite 120, Tampa, FL 33610-8302.
- b) For electronic mail: SAJ-RD-Enforcement@usace.army.mil (not to exceed 10 MB).

The Permittee shall reference this permit number, SAJ-2021-02516(GP/NW-JLC), on all submittals.

2. **Commencement Notification:** Within 10 days from the date of initiating the work authorized by this permit, the Permittee shall submit a completed "Commencement Notification" Form (attached).

3. **Self-Certification:** Within sixty (60) days of completion of the authorized work or at the expiration of the construction authorization of this permit, whichever occurs first, the Permittee shall complete the attached "Self-Certification Statement of Compliance" form and submit to the Corps. In the event that the completed work deviates, in any manner, from the authorized work, the Permittee shall describe, on the Self-Certification Form, the deviations between the work authorized by the permit and the work as constructed. Please note that the description of any deviations on the Self-Certification Form does not constitute approval of any deviations by the Corps.

#### **4. Cultural Resources/Historic Properties:**

- a) No structure or work shall adversely affect impact or disturb properties listed in the National Register of Historic Places (NRHP) or those eligible for inclusion in the NRHP.
- b) If during the ground disturbing activities and construction work within the permit area, there are archaeological/cultural materials encountered which were not the subject of a previous cultural resources assessment survey (and which shall include, but not be limited to: prehistoric or historic artifacts, pottery, modified shell, flora, fauna, human remains, ceramics, stone tools or metal implements, projectile points, dugout canoes, evidence of structures or any other physical remains that could be associated with Native American cultures or early colonial, early European, or American settlement), the Permittee shall immediately stop all work and ground-disturbing activities within a 100-meter diameter of the discovery and notify the Corps within the same business day (8 hours). The Corps shall then notify the Florida State Historic Preservation Officer (SHPO) and the appropriate Tribal Historic Preservation Officer(s) (THPO(s)) to assess the significance of the discovery and devise appropriate actions.
- c) Additional cultural resources assessments may be required of the permit area in the case of unanticipated discoveries as referenced in accordance with the above Special Condition; and if deemed necessary by the SHPO, THPO(s), or Corps, in accordance with 36 CFR 800 or 33 CFR 325, Appendix C (5). Based on the circumstances of the discovery, equity to all parties, and considerations of the public interest, the Corps may modify, suspend or revoke the permit in accordance with 33 CFR Part 325.7. Such activity shall not resume on non-federal lands without written authorization from the SHPO for finds under his or her jurisdiction, and from the Corps.
- d) In the unlikely event that unmarked human remains are identified on non-federal lands, they will be treated in accordance with Section 872.05 Florida Statutes. All work and ground disturbing activities within a 100-meter diameter of the unmarked human remains shall immediately cease and the Permittee shall immediately notify the medical examiner, Corps, and State Archaeologist within the same business day (8-hours). The Corps shall then notify the appropriate SHPO and THPO(s). Based on the circumstances of the discovery, equity to all parties, and considerations of the public interest, the Corps may modify, suspend or revoke the permit in accordance with 33 CFR Part 325.7. Such activity shall not resume without written authorization from the State Archaeologist and from the Corps.

**5. Assurance of Navigation and Maintenance:** The Permittee understands and agrees that, if future operations by the United States require the removal, relocation, or other alteration, of the structures or work herein authorized, or if in the opinion of the Secretary of the Army or his authorized representative, said structure or work shall cause unreasonable obstruction to the free navigation of the navigable waters, the Permittee will be required, upon due notice from the Corps of Engineers, to remove, relocate, or alter the structural work or obstructions caused thereby, without expense to the United States. No claim shall be made against the United States on account of any such removal or alteration.

**6. Manatee Conditions:** The Permittee shall comply with the “Standard Manatee Conditions for In-Water Work – 2011,” attached.

**7. Jacksonville District Programmatic Biological Opinion (JAXBO), November 2017, Project Design Criteria (PDCs):** Work authorized under this permit must comply with all applicable PDCs, based on the permitted activity, as required by JAXBO. Please note that failure to comply with the applicable PDCs, where a take of listed species occurs, would constitute an unauthorized take, and noncompliance with this permit. The NMFS is the appropriate authority to enforce the terms and conditions of JAXBO. The most current version of JAXBO can be accessed at the Jacksonville District Regulatory Division internet webpage in the Endangered Species section of the Sourcebook located at:

<http://www.saj.usace.army.mil/Missions/Regulatory/SourceBook.aspx>

**Note** - JAXBO may be subject to revision at any time. The most recent version of these conditions must be utilized during the design and construction of the permitted work. In accordance with the Endangered Species Act, and for those projects which do not comply with JAXBO, the Corps will seek individual consultation with the NMFS.

**Note** - some authorized activities may deviate from the PDCs. In cases where the activity (i.e., structure dimensions, length, etc.) deviates from the PDCs, the permit drawings shall supersede the PDCs.

For each of the following authorized activities subject of this permit, the permittee shall adhere to the following PDCs, which are attached to, and made part of, this authorization:

Activity 1 – Shoreline Stabilization (AP.1-11; A1.1-7; S2)

Activity 2 – Pile-supported Structures and Anchored Buoys: (AP.1-11; A2.1-9; S2)

Activity 6 – Boat Ramps (AP.1-11; A6.1-6)

**8. Turbidity Barriers:** Prior to the initiation of any of the work authorized by this permit the Permittee shall install floating turbidity barriers with weighted skirts that extend to within 1 foot of the bottom around all work areas that are in, or adjacent to, surface waters. The turbidity barriers shall remain in place and be maintained until the authorized work has been completed and all erodible materials have been stabilized. Turbidity curtains must be removed once turbidity reaches background levels.

**9. Fill Material:** The Permittee shall use only clean fill material for this project. The fill material shall be free from items such as trash, debris, automotive parts, asphalt, construction materials, concrete block with exposed reinforcement bars, and soils contaminated with any toxic substance, in toxic amounts in accordance with Section 307 of the Clean Water Act.

**10. Agency Changes/Approvals:** Should any other agency require and/or approve changes to the work authorized or obligated by this permit, the Permittee is advised a reverification to this permit instrument is required prior to initiation of those changes. It is the Permittee's responsibility to request a reverification of this permit from the Tampa Permits Section. The Corps reserves the right to fully evaluate, amend, and approve or deny the request for reverification of this permit.

**11. Posting of permit:** The Permittee shall have available and maintain for review a copy of this permit and approved plans at the construction site.

**12. WQC/CZCC:** Prior to the initiation of any construction, projects qualifying for this DA permit must qualify for an exemption under section 403.813(1), Florida Statutes or 373.406, Florida Statutes, or otherwise be authorized by the applicable permit required under Part IV of Chapter 373, Florida Statutes, by the Department of Environmental Protection, a water management district under section 373.069, Florida Statutes, or a local government with delegated authority under section 373.441, Florida Statutes, and receive Water Quality Certification and applicable Coastal Zone Consistency Concurrence or waiver thereto, as well as any authorizations required for the use of state-owned submerged lands under Chapter 253, Florida Statutes, and, as applicable, Chapter 258, Florida Statutes. You should check State-permitting requirements with the Florida Department of Environmental Protection or the appropriate water management district.

This letter of authorization does not include conditions that would prevent the 'take' of a state-listed fish or wildlife species. These species are protected under sec. 379.411, Florida Statutes, and listed under Rule 68A-27, Florida Administrative Code. With regard to fish and wildlife species designated as species of special concern or threatened by the State of Florida, you are responsible for coordinating directly with the Florida Fish and Wildlife Conservation Commission (FWC). You can visit the FWC

license and permitting webpage (<http://www.myfwc.com/license/wildlife/>) for more information, including a list of those fish and wildlife species designated as species of special concern or threatened. The Florida Natural Areas Inventory (<http://www.fnai.org/>) also maintains updated lists, by county, of documented occurrences of those species.

This letter of authorization does not give absolute Federal authority to perform the work as specified on your application. The proposed work may be subject to local building restrictions mandated by the National Flood Insurance Program. You should contact your local office that issues building permits to determine if your site is located in a flood-prone area, and if you must comply with the local building requirements mandated by the National Flood Insurance Program.

This letter of authorization does not preclude the necessity to obtain any other Federal, State, or local permits, which may be required.

Thank you for your cooperation with our permit program. The Corps' Jacksonville District Regulatory Division is committed to improving service to our customers. We strive to perform our duty in a friendly and timely manner while working to preserve our environment. We invite you to complete our automated Customer Service Survey at <https://regulatory.ops.usace.army.mil/customer-service-survey/>. Please be aware this Internet address is case sensitive and you will need to enter it exactly as it appears above. Your input is appreciated – favorable or otherwise.

Should you have any questions related to this NWP verification or have issues accessing the documents referenced in this letter, please contact Jessica Cordwell at the letterhead address above, via telephone at 813-769-7067, or via e-mail at [Jessica.L.Cordwell@usace.army.mil](mailto:Jessica.L.Cordwell@usace.army.mil).

Sincerely,

Jessica Cordwell  
Project Manager

Enclosures:  
Project drawings  
Manatee conditions  
JaxBO conditions  
Commencement Notification form

Self-Certification form  
Permit Transfer form

Cc:  
gtimmins@cecifl.com  
alan.laihipp@mymanatee.org



# HIGHLAND SHORES BOAT RAMP REPAIR PERMIT DRAWINGS

RECEIVED 14 OCT 2021  
CESAJ-RD-WT

PREPARED FOR:  
MANATEE COUNTY BOARD OF COUNTY COMMISSIONERS

## INDEX

1. COVER SHEET
2. EXISTING CONDITIONS
3. PROPOSED PLAN
4. PROPOSED TYPICAL SECTIONS

## NOTES

1. SURVEY COMPLETED BY COASTAL ENGINEERING CONSULTANTS, INC., ON 3/11/2021.
2. POST-CONSTRUCTION BATHYMETRIC SURVEY COMPLETED BY COASTAL ENGINEERING CONSULTANTS, INC., ON 5/13/2019.
3. PLANE COORDINATES ARE BASED ON THE TRANSVERSE MERCATOR PROJECTION FOR THE WEST ZONE OF FLORIDA AND REFERENCED TO THE NORTH AMERICAN DATUM OF 1983 (NAD 83).
4. ELEVATIONS SHOWN HEREON ARE IN FEET AND TENTHS AND REFERENCED TO THE NORTH AMERICAN VERTICAL DATUM OF 1988 (NAVD 1988). REFERENCE BENCHMARK: W 565, EL. = 8.73 FT NAVD AND SAINT LUCIE, EL. = 6.90 FT NAVD.
5. SURVEY ACCURACY STANDARDS, QUALITY CONTROL, AND QUALITY ASSURANCE REQUIREMENTS WERE FOLLOWED DURING THIS SURVEY IN ACCORDANCE WITH USACE EM 1110-2-1003, HYDROGRAPHIC SURVEYING MANUAL, 11/30/2013.
6. INFORMATION SHOWN HEREON REFLECTS CONDITIONS AS THEY EXISTED ON THE SURVEY DATE SHOWN AND CAN ONLY BE CONSIDERED INDICATIVE OF CONDITIONS AT THAT TIME.
7. AERIAL PHOTOGRAPHY OBTAINED FROM THE FLORIDA DEPARTMENT OF TRANSPORTATION, DATED 2020.



**LOCATION MAP**  
N.T.S.

FOR PERMITTING  
PURPOSES ONLY.  
NOT TO BE USED FOR  
CONSTRUCTION.

## PUBLISHED TIDAL INFORMATION

TIDAL DATUMS AT BRADENTON, MANATEE RIVER  
ARE BASED ON FLORIDA 872 6247 TIDE STATION,  
PUBLISHED 05-11-2015.  
LENGTH OF SERIES = 1 YEAR  
TIME PERIOD = JANUARY 1977 - DECEMBER 1977  
TIDAL EPOCH = 1983 - 2001  
CONTROL TIDE STATION = 872 6520 ST PETERSBURG, TAMPA BAY

ELEVATIONS OF TIDAL DATUMS ARE REFERENCED IN  
NAVD 1988.

MEAN HIGH WATER (MHW) = +0.47 FT NAVD  
MEAN TIDE LEVEL (MTL) = -0.35 FT NAVD  
MEAN LOW WATER (MLW) = -1.18 FT NAVD  
MEAN LOWER LOW WATER (MLLW) = -1.51 FT NAVD

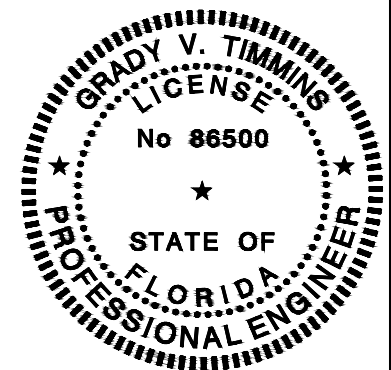

SHEET 1  
FILE NO.: 20204-P-1

**COASTAL ENGINEERING CONSULTANTS INC.**  
Serving Florida Since 1977  
28421 BONITA CROSSINGS BLVD  
BONITA SPRINGS, FLORIDA 34135

COASTAL & MARINE ENGINEERING  
ENVIRONMENTAL & GEOLOGICAL SERVICES  
SURVEY AND MAPPING  
ENGINEERING: CA 2464  
SURVEYING: LB 2464  
PHONE: (239)643-2324  
FAX: (239)643-1143  
www.coastalengineering.com  
E-Mail: info@cecifi.com

CLIENT:	MANATEE COUNTY
TITLE:	HIGHLAND SHORES BOAT RAMP COVER SHEET

DATE:	6/14/2021	SCALE:	AS NOTED
DRAWN:	GVT	F.B.	
CHECKED:	MAK	PG.	
SEC.	TWP.	RNG.	
ACAD NO.	20204-P.dwg		
REF. NO.	20.204		

NO.	DATE	BY	REVISION DESCRIPTION
2	10/14/2021	GVT	USACE RAI #1
1	8/27/2021	GVT	DEP RAI #1

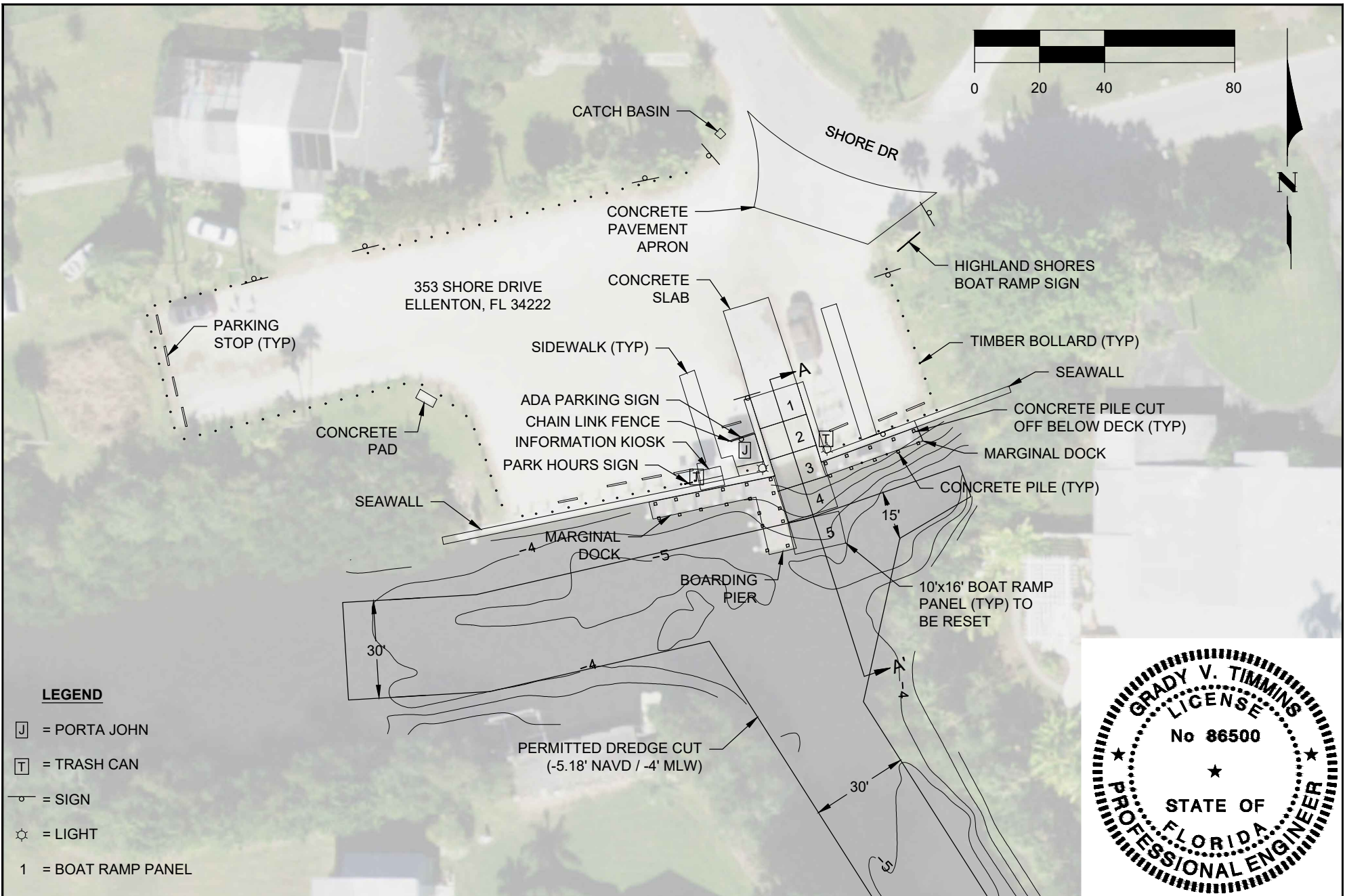

**LEGEND**

- J = PORTA JOHN
- T = TRASH CAN
- = SIGN
- = LIGHT
- 1 = BOAT RAMP PANEL

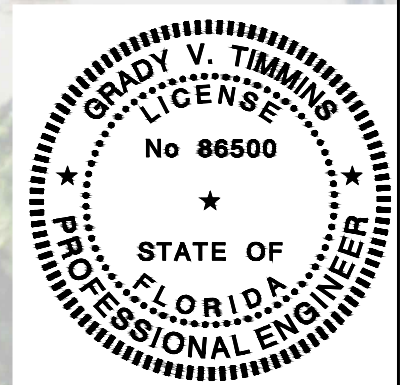

SHEET 2 FILE NO.: 20204-P-2	<b>COASTAL ENGINEERING CONSULTANTS INC.</b> Serving Florida Since 1977 28421 BONITA CROSSINGS BLVD BONITA SPRINGS, FLORIDA 34135	COASTAL & MARINE ENGINEERING ENVIRONMENTAL & GEOLOGICAL SERVICES SURVEY AND MAPPING ENGINEERING: CA 2464 SURVEYING: LB 2464  PHONE: (239)643-2324 FAX: (239)643-1143 www.coastalengineering.com E-Mail: info@cecifi.com	CLIENT:	MANATEE COUNTY	DATE:	6/14/2021	SCALE:	AS NOTED
			TITLE:	HIGHLAND SHORES BOAT RAMP EXISTING CONDITIONS	DRAWN:	GVT	F.B.	
				CHECKED:	MAK	PG.		
				SEC.	TWP.	RNG.		
				ACAD NO.	20204-P.dwg			
				REF. NO.	20.204			
					NO.	DATE	BY	REVISION DESCRIPTION
					2	10/14/2021	GVT	USACE RAI #1
					1	8/27/2021	GVT	DEP RAI #1

**LEGEND**

1 = BOAT RAMP PANEL

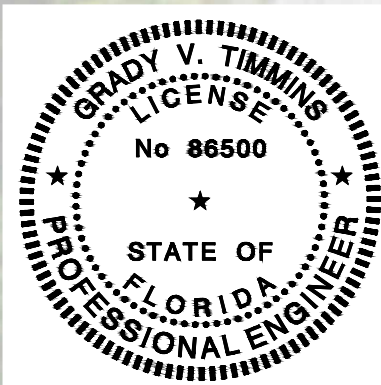
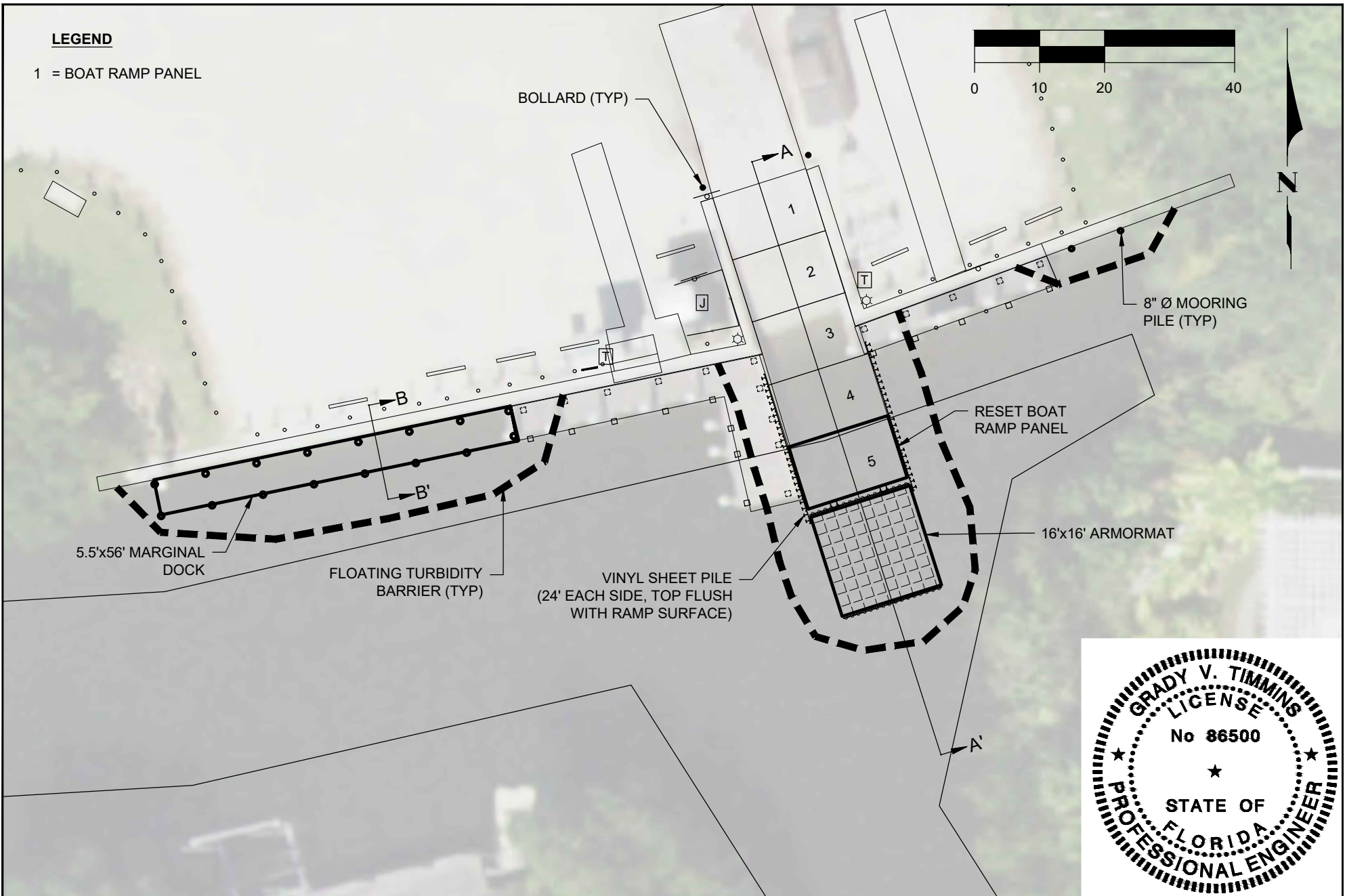
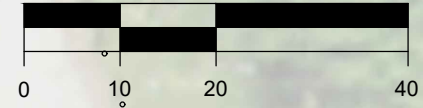

<p>SHEET 3 FILE NO.: 20204-P-3</p> <p><b>COASTAL ENGINEERING CONSULTANTS INC.</b> Serving Florida Since 1977 28421 BONITA CROSSINGS BLVD BONITA SPRINGS, FLORIDA 34135</p>	<p>COASTAL &amp; MARINE ENGINEERING ENVIRONMENTAL &amp; GEOLOGICAL SERVICES SURVEY AND MAPPING ENGINEERING: CA 2464 SURVEYING: LB 2464</p>		<p>CLIENT: <b>MANATEE COUNTY</b></p>	<p>DATE: 6/14/2021 SCALE: AS NOTED</p>			
	<p>PHONE: (239)643-2324 FAX: (239)643-1143 www.coastalengineering.com E-Mail: info@cecifl.com</p>		<p>TITLE: <b>HIGHLAND SHORES BOAT RAMP PROPOSED PLAN</b></p>	<p>DRAWN: GVT F.B.</p>			
				<p>CHECKED: MAK PG.</p>			
				<p>SEC. TW. P. RNG.</p>			
				<p>ACAD NO. 20204-P.dwg</p>	2	10/14/2021	GVT
			<p>REF. NO. 20.204</p>	1	8/27/2021	GVT	DEP RAI #1
				NO.	DATE	BY	REVISION DESCRIPTION

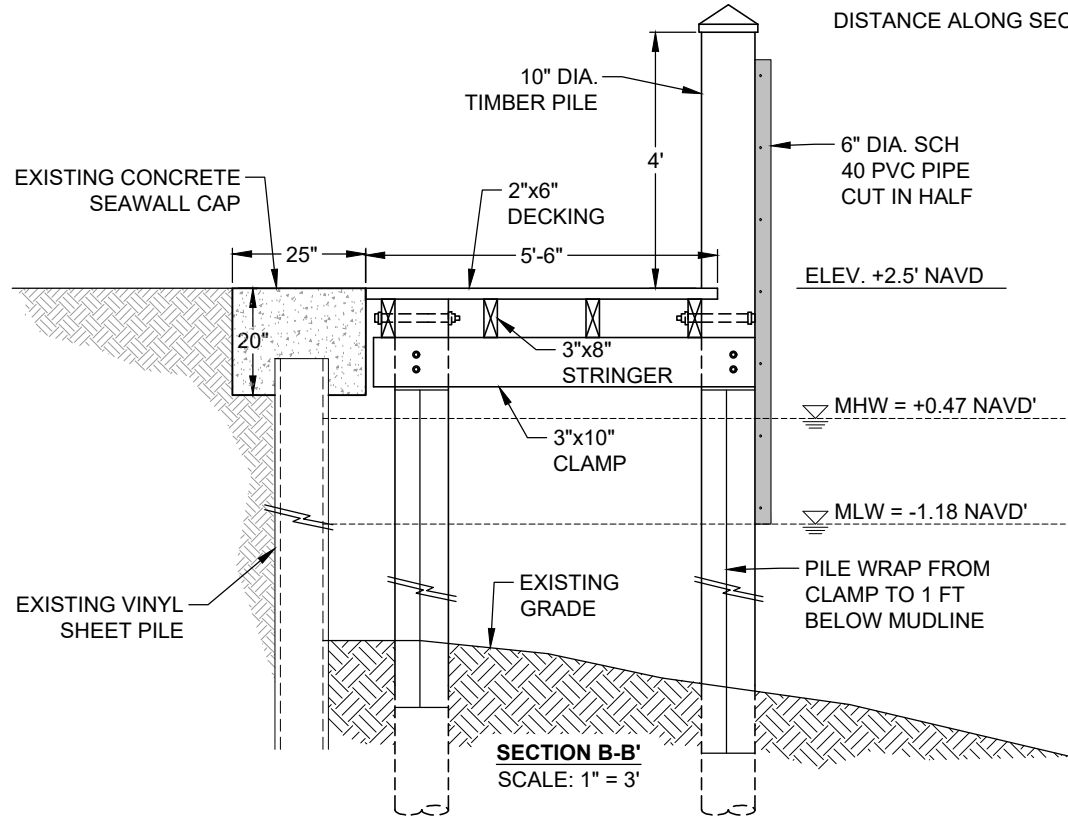
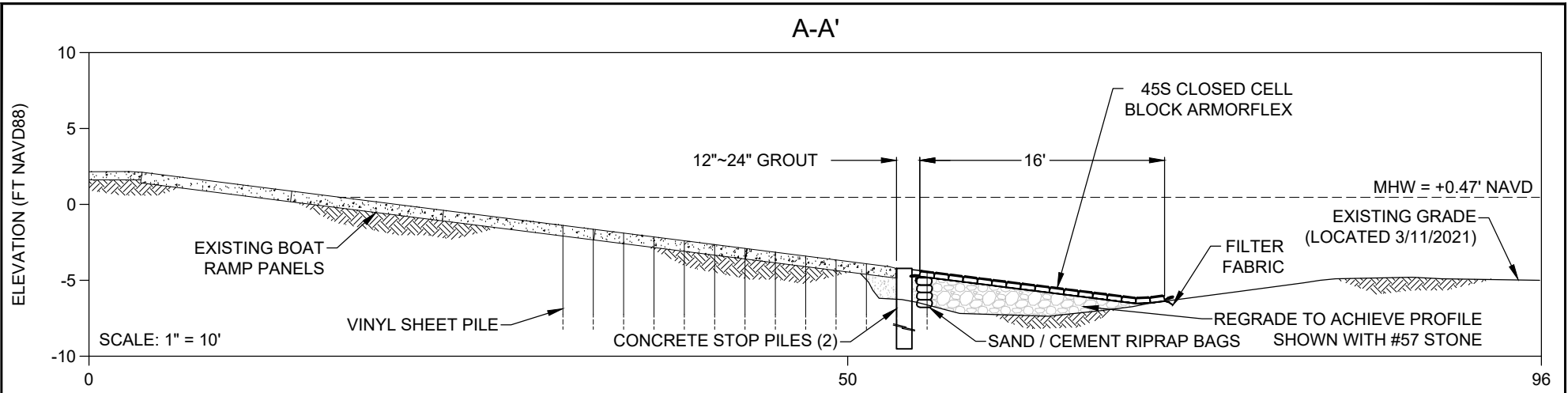

NO DREDGING / NO REMOVAL OF EXISTING MATERIAL

APPROXIMATE MATERIAL VOLUME / ACREAGE  
 GROUT & SAND/CEMENT BAGS: 4 CY / 0.009 AC  
 BEDDING STONE: 11 CY / 0.01 AC  
 CONCRETE MATS: 4 CY / 0.006 AC  
 REGRADE CANAL BOTTOM: 12 CY / 0.007 AC

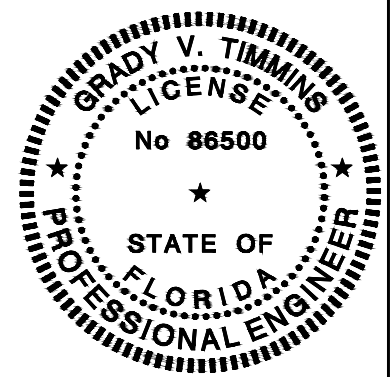

SHEET 4 FILE NO.: 20204-P4 <b>COASTAL ENGINEERING CONSULTANTS INC.</b> Serving Florida Since 1977 28421 BONITA CROSSINGS BLVD BONITA SPRINGS, FLORIDA 34135	COASTAL & MARINE ENGINEERING ENVIRONMENTAL & GEOLOGICAL SERVICES SURVEY AND MAPPING ENGINEERING: CA 2464 SURVEYING: LB 2464		CLIENT: <b>MANATEE COUNTY</b>	DATE: 6/14/2021 DRAWN: GVT CHECKED: MAK SEC.: TWP. RNG.	SCALE: AS NOTED F.B. PG.					
	TITLE: <b>HIGHLAND SHORES BOAT RAMP PROPOSED TYPICAL SECTIONS</b>									
							2	10/14/2021	GVT	USACE RAI #1
							1	8/27/2021	GVT	DEP RAI #1



## STANDARD MANATEE CONDITIONS FOR IN-WATER WORK

2011

The permittee shall comply with the following conditions intended to protect manatees from direct project effects:

- a. All personnel associated with the project shall be instructed about the presence of manatees and manatee speed zones, and the need to avoid collisions with and injury to manatees. The permittee shall advise all construction personnel that there are civil and criminal penalties for harming, harassing, or killing manatees which are protected under the Marine Mammal Protection Act, the Endangered Species Act, and the Florida Manatee Sanctuary Act.
- b. All vessels associated with the construction project shall operate at "Idle Speed/No Wake" at all times while in the immediate area and while in water where the draft of the vessel provides less than a four-foot clearance from the bottom. All vessels will follow routes of deep water whenever possible.
- c. Siltation or turbidity barriers shall be made of material in which manatees cannot become entangled, shall be properly secured, and shall be regularly monitored to avoid manatee entanglement or entrapment. Barriers must not impede manatee movement.
- d. All on-site project personnel are responsible for observing water-related activities for the presence of manatee(s). All in-water operations, including vessels, must be shutdown if a manatee(s) comes within 50 feet of the operation. Activities will not resume until the manatee(s) has moved beyond the 50-foot radius of the project operation, or until 30 minutes elapses if the manatee(s) has not reappeared within 50 feet of the operation. Animals must not be herded away or harassed into leaving.
- e. Any collision with or injury to a manatee shall be reported immediately to the Florida Fish and Wildlife Conservation Commission (FWC) Hotline at 1-888-404-3922. Collision and/or injury should also be reported to the U.S. Fish and Wildlife Service in Jacksonville (1-904-731-3336) for north Florida or Vero Beach (1-772-562-3909) for south Florida, and to FWC at [ImperiledSpecies@myFWC.com](mailto:ImperiledSpecies@myFWC.com)
- f. Temporary signs concerning manatees shall be posted prior to and during all in-water project activities. All signs are to be removed by the permittee upon completion of the project. Temporary signs that have already been approved for this use by the FWC must be used. One sign which reads *Caution: Boaters* must be posted. A second sign measuring at least 8 ½" by 11" explaining the requirements for "Idle Speed/No Wake" and the shut down of in-water operations must be posted in a location prominently visible to all personnel engaged in water-related activities. These signs can be viewed at [MyFWC.com/manatee](http://MyFWC.com/manatee). Questions concerning these signs can be sent to the email address listed above.

# CAUTION: MANATEE HABITAT

All project vessels

**IDLE SPEED / NO WAKE**

When a manatee is within 50 feet of work  
all in-water activities must

**SHUT DOWN**

Report any collision with or injury to a manatee:

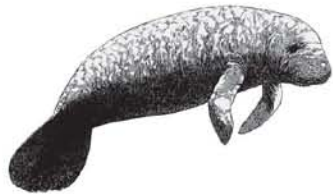

**Wildlife Alert:**

**1-888-404-FWCC(3922)**

cell \*FWC or #FWC



# Caution Boaters

## Watch for Manatees

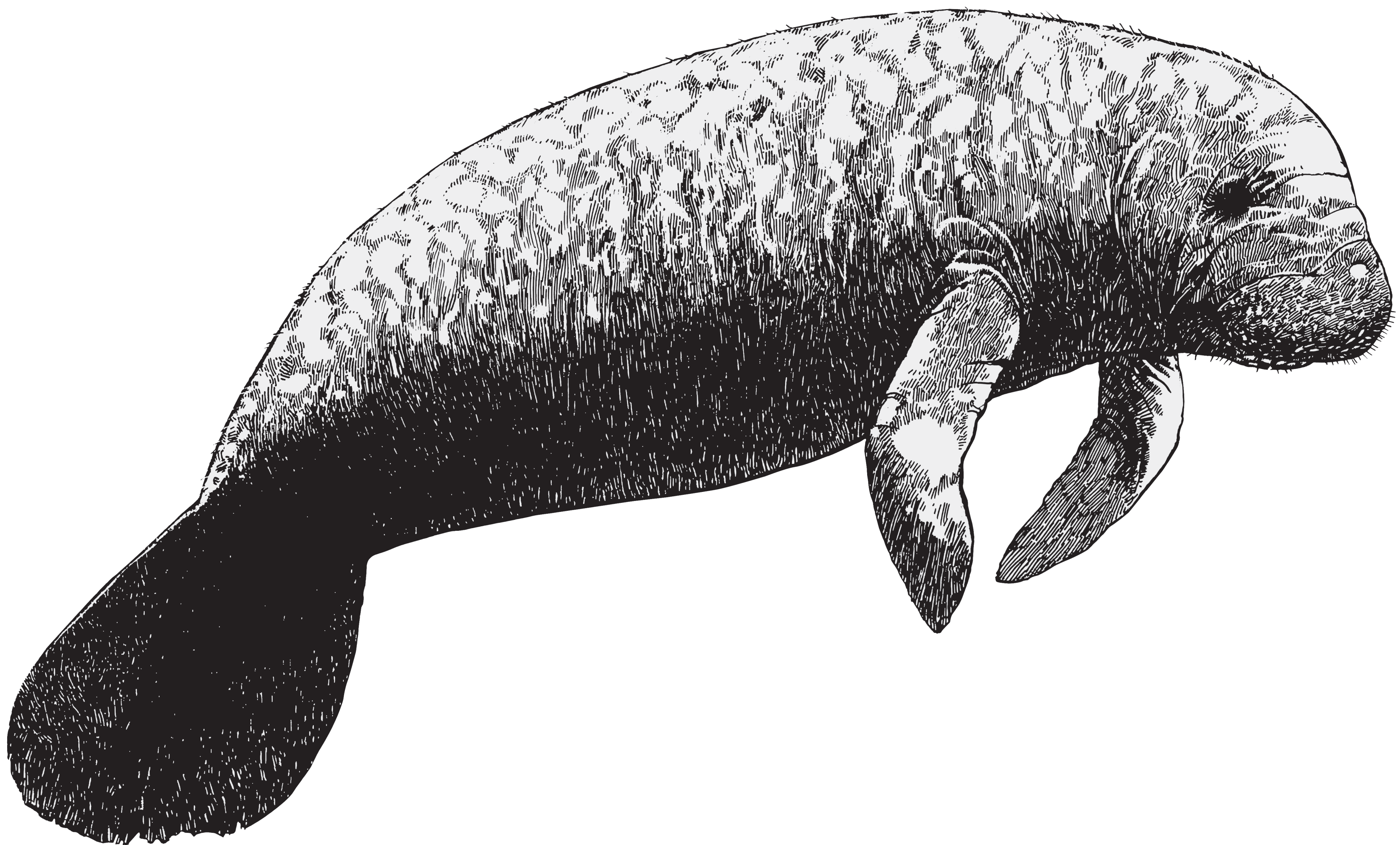

**Wildlife Alert:**  
**1-888-404-FWCC(3922)**  
cell \*FWC or #FWC

Report collisions, sick, dead or injured manatees  
and any wildlife or boating law violations.

## Project Design Criteria (PDCs) Applicable to All Projects

**NOTE** - You are required to comply with the following PDCs, which serve to address requirements pursuant to Section 7, Endangered Species Act (ESA) for those listed species and designated critical habitat under purview of the National Marine Fisheries Service Protected, Resources Division. These PDCs are taken from the Programmatic Biological Opinion (PBO) referred to as JaxBO. These criteria serve to address ESA requirements only, and additional conditions may be required to address other Federal laws, including the Magnuson-Stevens Fishery Conservation and Management Reauthorization Act. Authorization under this permit is conditional upon your compliance with all applicable PDCs, which are made part of this permit. You are reminded that you must complete the attached self-certification statement of compliance following completion of the authorized work. Your statement of compliance does not obviate the need to satisfy all PDCs, including those requirements (e.g., such as structural dimensions and educational signs) that are observable post-construction, and those requirements (e.g., construction methods or procedures to be followed) that are not observable post-construction. Please note that failure to comply with the applicable PDCs of this PBO, where a take of the listed species occurs, would constitute an unauthorized take, and it would also constitute noncompliance with this permit. The NMFS is the appropriate authority to determine compliance with the terms and conditions of this PBO.

**AP.1.** The applicant must agree to adhere to PDCs for *In-Water Activities* (provided below).

**AP.2.** All projects involving the installation of piles or sheet piles shall follow the PDCs for *In-Water Noise from Pile and Sheet Pile Installation* (Section 2.2). This Opinion does not cover projects that use seismic surveys, low frequency sonar, explosions, and seismic air guns.

**AP.3.** All projects proposed in or near areas with mangroves, seagrasses, corals, or hard bottom habitat must refer to PDCs for *Mangroves, Seagrasses, Corals, and Hard Bottom for All Projects* (provided below) to determine whether the project is covered under the Opinion and, if it is covered, to ensure it is sited, designated, and implemented following all of the PDCs in that section.

**AP.4.** For every project, the USACE must determine if the project is located within:

- a) Smalltooth sawfish critical habitat limited exclusion zones (Section 2.1.1.1)
- b) Gulf sturgeon critical habitat migratory restriction zones (Section 2.1.1.2)
- c) Atlantic sturgeon critical habitat exclusion zone (St. Marys River) (Section 2.1.1.3)
- d) North Atlantic right whale educational sign zones (Section 2.1.1.4)
- e) U.S. Caribbean sea turtle critical habitat restriction zones (Section 2.1.1.5)
- f) Bryde's whale exclusion zone (Section 2.1.1.6)

Where the activity is excluded from the Opinion within a particular zone, the application must be processed under a separate consultation. Where additional restrictions apply to activities within that zone, the USACE or other authorizing entity must ensure that the project meets the requirements for that zone.

**AP.5.** This Opinion only covers new construction (i.e., installation, repair, replacement) and does not apply to after-the-fact consultations or enforcement actions handled by the Corps.

**AP.6.** All activities must be completed during daylight hours.



**U.S. Army Corps of Engineers Jacksonville District's Programmatic Biological Opinion (JaxBO) Project Design Criteria (PDCs) for In-Water Activities**

**November 20, 2017**

- 1) **(AP.7.) Education and Observation:** The permittee must ensure that all personnel associated with the project are instructed about the potential presence of species protected under the ESA and the Marine Mammal Protection Act (MMPA). All on-site project personnel are responsible for observing water-related activities for the presence of protected species. All personnel shall be advised that there are civil and criminal penalties for harming, harassing, or killing ESA-listed species or marine mammals. To determine which species may be found in the project area, please review the relevant Protected Species List at:  
[http://sero.nmfs.noaa.gov/protected\\_resources/section\\_7/threatened\\_endangered/index.html](http://sero.nmfs.noaa.gov/protected_resources/section_7/threatened_endangered/index.html)
- 2) **(AP.8.) Reporting** of interactions with protected species:
  - a) Any collision(s) with and/or injury to any sea turtle, sawfish, whale, or sturgeon occurring during the construction of a project, shall be reported immediately to NMFS's Protected Resources Division (PRD) at (1-727-824-5312) or by email to [takereport.nmfs@noaa.gov](mailto:takereport.nmfs@noaa.gov) and [SAJ-RD-Enforcement@usace.army.mil](mailto:SAJ-RD-Enforcement@usace.army.mil).
  - b) Smalltooth sawfish: Report sightings to 1-844-SAWFISH or email [Sawfish@MyFWC.com](mailto:Sawfish@MyFWC.com)
  - c) Sturgeon: Report dead sturgeon to 1-844-STURG 911 (1-844-788-7491) or email [nmfs.ser.sturgeonnetwork@noaa.gov](mailto:nmfs.ser.sturgeonnetwork@noaa.gov)
  - d) Sea turtles and marine mammals: Report stranded, injured, or dead animals to 1-877-WHALE HELP (1-877-942-5343).
  - e) North Atlantic right whale: Report injured, dead, or entangled right whales to the USCG via VHF Channel 16.
- 3) **(AP.9.) Vessel Traffic and Construction Equipment:** All vessel operators must watch for and avoid collision with species protected under the ESA and MMPA. Vessel operators must avoid potential interactions with protected species and operate in accordance with the following protective measures:
  - a) *Construction Equipment:*
    - i) All vessels associated with the construction project shall operate at "Idle Speed/No Wake" at all times while operating in water depths where the draft of the vessel provides less than a 4-foot (ft) clearance from the bottom, and in all depths after a protected species has been observed in and has departed the area.
    - ii) All vessels will follow marked channels and/or routes using the maximum water depth whenever possible.
    - iii) Operation of any mechanical construction equipment, including vessels, shall cease immediately if a listed species is observed within a 50-ft radius of

construction equipment and shall not resume until the species has departed the area of its own volition.

- iv) If the detection of species is not possible during certain weather conditions (e.g., fog, rain, wind), then in-water operations will cease until weather conditions improve and detection is again feasible.

b) *All Vessels:*

- i) Sea turtles: Maintain a minimum distance of 150 ft.
- ii) North Atlantic right whale: Maintain a minimum 1,500-ft distance (500 yards).
- iii) Vessels 65 ft in length or longer must comply with the Right Whale Ship Strike Reduction Rule (50 CFR 224.105) which includes reducing speeds to 10 knots or less in Seasonal Management Areas (<http://www.fisheries.noaa.gov/pr/shipstrike/>).
- iv) Mariners shall check various communication media for general information regarding avoiding ship strikes and specific information regarding right whale sightings in the area. These include NOAA weather radio, USCG NAVTEX broadcasts, and Notices to Mariners.
- v) Marine mammals (i.e., dolphins, whales [other than North Atlantic right whales], and porpoises): Maintain a minimum distance of 300 ft.
- vi) When these animals are sighted while the vessel is underway (e.g., bow-riding), attempt to remain parallel to the animal's course. Avoid excessive speed or abrupt changes in direction until they have left the area.
- vii) Reduce speed to 10 knots or less when mother/calf pairs or groups of marine mammals are observed, when safety permits.

- 4) **(AP.10.) Turbidity Control Measures during Construction:** Turbidity must be monitored and controlled. Prior to initiating any of the work covered under this Opinion, the Permittee shall install turbidity curtains as described below. In some instances, the use of turbidity curtains may be waived by the USACE project manager if the project is deemed too minimal to generate turbidity (e.g., certain ATON installation, scientific survey device placement, marine debris removal) or if the current is too strong for the curtains to stay in place. Turbidity curtains specifications:

- a) Install floating turbidity barriers with weighted skirts that extend to within 1 ft of the bottom around all work areas that are in, or adjacent to, surface waters.
- b) Use these turbidity barriers throughout construction to control erosion and siltation and ensure that turbidity levels within the project area do not exceed background conditions.
- c) Position turbidity barriers in a way that does not block species' entry to or exit from designated critical habitat.
- d) Monitor and maintain turbidity barriers in place until the authorized work has been completed and the water quality in the project area has returned to background conditions.
- e) In the range of ESA-listed corals (St. Lucie Inlet, Martin County south to the Dry Tortugas and the U.S. Caribbean) and Johnson's seagrass (Turkey Creek/Palm

Bay south to central Biscayne Bay in the lagoon systems on the east coast of Florida):

- i) Projects that include upland earth moving (e.g., grading to install a building or parking lot associated with a dock and seawall project), must install sediment control barriers to prevent any upland sediments from reaching estuarine or marine waters.
  - ii) The turbidity curtain requirement cannot be waived for any project that moves or removes sediment (e.g., dredging, auger to create a pile, trenching to install a cableline). If turbidity curtains are not feasible in an area based on site conditions such as water current, high wave action, or stormy conditions, the project must undergo individual Section 7 consultation and is not covered under this Programmatic Opinion.
- 5) **(AP.11.) Entanglement:** All turbidity curtains and other in-water equipment must be properly secured with materials that reduce the risk of entanglement of marine species (described below). Turbidity curtains likewise must be made of materials that reduce the risk of entanglement of marine species.
- a) In-water lines (rope, chain, and cable, including the lines to secure turbidity curtains) must be stiff, taut, and non-looping. Examples of such lines are heavy metal chains or heavy cables that do not readily loop and tangle. Flexible in-water lines, such as nylon rope or any lines that could loop or tangle, must be enclosed in a plastic or rubber sleeve/tube to add rigidity and prevent the line from looping and tangling. In all instances, no excess line is allowed in the water.
  - b) Turbidity curtains and other in-water equipment must be placed in a manner that does not entrap species within the construction area or block access for them to navigate around the construction area.

## **Project Design Criteria (PDCs) specific to Activity 1 for Shoreline Stabilization**

### **A1.1.** Activities covered by this Opinion include:

- A1.1.1. New shoreline stabilization: New shoreline stabilization projects cannot exceed 500 ft in length. New seawalls and footers cannot extend any further waterward than 1.5 ft (18 in) from MHW, unless necessary to align a new seawall with 1 or more adjacent seawalls.  
Repair or replacement of existing vertical seawalls: The repair, and replacement of seawalls and footers cannot extend any further waterward than 1.5 ft (18 in) from the wet face of the existing seawall or MHW, unless necessary to align with 1 or more adjacent seawalls. The repair or replacement of an existing seawall is not restricted to the 500 ft in length limit in PDC A1.1.1.
- A1.1.2. Shoreline stabilization materials may consist of riprap, articulating blocks or mats, and sand cement, geotextile/ filter fabric and mattresses. Installation of new shoreline stabilization materials where none previously existed may not extend more than 10 ft waterward of MHW (including the toe of the riprap). Riprap repair, and replacement may occur at its previous location, upland of, or within 1.5 ft (18 in) waterward of its previous location.
- A1.1.3. The Opinion does not cover removal of any length of seawall or other shoreline stabilization materials if such removal would result in an unstabilized shoreline.
- A1.1.4. The Opinion covers installation, repair, replacement, and removal of seawall footers.
- A1.1.5. This Opinion covers the removal/fill of upland cut boat ramps, slips, and basins to return the shoreline to the natural contour and/or to bring the shoreline into alignment with the adjacent property shorelines.

### **The following PDCs apply to all the activities described in PDC A1.1 above:**

- A1.2.** Placement of backfill is limited to those situations where it is necessary to level the land behind seawalls or riprap. This includes backfill associated with installation of a seawall or riprap to remove/fill in an upland cut area (e.g., boat slip, boat ramp, boat basins) to return the shoreline to the original shape or to connect to adjacent seawalls to bring the shoreline into alignment with adjacent property shorelines.
- A1.3.** Shoreline stabilization materials must be placed by hand around red mangrove prop roots.
- A1.4.** Shoreline stabilization structures, other than vertical seawalls, shall be no steeper than a 2:1 Horizontal: Vertical slope for riprap, or the appropriate slope necessary to ensure shoreline stability while minimizing the total footprint when using materials other than riprap.

- A1.5.** Installation and/or repairs to groins, jetties, or other structures placed perpendicular to shore, and beach nourishment/renourishment are not covered in this Opinion. Breakwaters/living shorelines are covered as described in Activity 7.
- A1.6.** No placement of riprap below MHW is covered under this Opinion within the boundary of the FKNMS unless the FKNMS issues a NOAA permit or authorization that signifies the proposed activity is consistent with Title III of the Marine Protection, Research, and Sanctuaries Act of 1972, as amended. Proof of approval from the FKNMS is required as part of the project level review submission, described in Section 2.3, below
- A1.7.** Shoreline protection shall not occur on ocean beaches used for sea turtle nesting.

## **Project Design Criteria (PDCs) Specific to Activity 2 for Pile-Supported Structures and Anchored Buoys**

**A2.1.** Activities covered by this Opinion include the installation, repair, replacement, and removal of structures as described below:

- A2.1.1. The pile-supported and anchored structures included in this Opinion are: docks and piers, boatlifts, mooring piles and dolphin piles associated with docks/piers; ATONs and PATONs; floating docks; pile-supported chickees (i.e., small, back-country, over-water, pile-supported, primitive camping shelters); boardwalks (as long as they are designed and clearly marked to prohibit fishing and vessel mooring); mooring fields and buoys; and other minor pile-supported structures. This does not include structures that support large commercial vessels including ferries, tankers, and cargo ships such as ferry terminals and large ports.
- A2.1.2. Pile-supported docks/piers for a single-family residential lot are limited to 4 slips for motorized vessels. Slips for non-motorized vessels (e.g., kayak, canoe, and paddleboard) and associated launching areas do not count toward the total slip number.
- A2.1.3. Pile-supported structures for marinas, multi-family facilities (e.g., condo complexes, trailer parks, subdivisions when the homeowners association owns and controls the in-water structures). Docks and piers for multi-family residential properties (e.g., condos, trailer parks, apartment complexes), and marinas are limited to a maximum of 50 total slips (i.e., combination of wet and dry slips for existing plus proposed slips).
- A2.1.4. Anchored buoys and temporary pile-supported structures associated with marine events. Upon completion of the event, these structures must be removed and, to the maximum extent practical, the site must be restored to pre-construction elevations. Water depths in the area of marine events must be deep enough to support at least 5 ft of water depth under the keel of a vessel and between the keel of a vessel and ESA-listed coral colonies when transiting to the mooring areas. There is no limit on the number of vessel slips allowed for temporary structures associated marine events such as boat shows.
- A2.1.5. Mooring fields are limited to a maximum of 50 motorized vessels (there is no limit on the number of non-motorized vessels).
- A2.1.6. All pile-supported structures constructed must comply with PDC 2.17 for *Docks or Other Minor Structures Constructed in Florida Under this Opinion* (see below).

**The following PDCs apply to all the activities described in PDC A2.1 above:**

**A2.2.** For commercial, multi-family, or public facilities, and marine events, signs must be posted in a visible location(s), alerting users of listed species in the area susceptible to vessel strikes and hook-and-line captures. The most current version of the signs that must be downloaded and sign installation guidance are available at:

([http://sero.nmfs.noaa.gov/protected\\_resources/section\\_7/protected\\_species\\_educational\\_signs/index.html](http://sero.nmfs.noaa.gov/protected_resources/section_7/protected_species_educational_signs/index.html)). The signs required to be posted by area are stated below:

- A2.2.1. All projects in Florida shall use the Save Sea Turtle, Sawfish, and Dolphin sign. These signs shall include contact information to the sea turtle and marine

- mammal stranding networks and smalltooth sawfish encounter database.
- A2.2.2. Projects within the North Atlantic right whale educational sign zone (as defined in Section 2.1.1.4) shall post the Help Protect North Atlantic Right Whales sign.
  - A2.2.3. On the east coast of Florida, projects located within the St. John's River and those occurring north of the St. Johns River to the Florida-Georgia line shall post the Report Sturgeon sign. On the west coast of Florida, projects occurring from the Cedar Key, Florida north to the Florida-Alabama line.
  - A2.2.4. We are still developing the signs to be used in the U.S. Caribbean. Once developed, those signs will be included at the website above.

**A2.3.** For commercial, multi-family, or public facilities, monofilament recycling bins must be provided at the docking facility to reduce the risk of turtle or sawfish entanglement in, or ingestion of, marine debris. Monofilament recycling bins must:

- A2.3.1. Be constructed and labeled according to the instructions provided at <http://mrrp.myfwc.com>.
- A2.3.2. Be maintained in working order and emptied frequently (according to <http://mrrp.myfwc.com> standards) so that they do not overflow.

**A2.4.** For any dock project (new construction, repair, or replacement) at a private residence located within 11 nautical miles of North Atlantic right whale critical habitat (as measured in a radius from the center of the nearest inlet to open ocean and described in Section 2.1.1.4), the property owner will be provided a handout with their USACE permit describing the presence of North Atlantic right whales in the area and the Federal regulations governing the approach to North Atlantic right whales (Appendix C).

**A2.5.** ATONs and PATONs must be approved by and installed in accordance with the requirements of the USCG (see 33 CFR, chapter I, subchapter C, part 66 and RHA Section 10 and any other pertinent requirements).

**A2.6.** Chickees must be less than 500 ft<sup>2</sup> and support no more than 2 slips.

**A2.7.** No activities associated with municipal or commercial fishing piers are covered under this Opinion.

**A2.8.** Docks installed within visible distance of ocean beaches are required to comply with turtle-friendly lighting, if lighting is necessary to the project. Turtle-friendly lighting is explained and examples are provided on the Florida Fish and Wildlife Conservation Commission website:  
<http://myfwc.com/wildlifehabitats/managed/sea-turtles/lighting/>

**A2.9.** Project construction will take place from uplands or from floating equipment (e.g., barge); prop or wheel-washing is prohibited.

## Project Design Criteria (PDCs) for In-Water Noise from Pile and Sheet Pile Installation

### Open Water

The letters A-E in the tables below specify the PDC category. Activities labeled A-D must follow the corresponding PDCs for labeled Category A-D below. Activities labeled E are excluded from this Opinion, as stated in Category E below.

	Trench and	Pilot hole (auger or	Jetting	Vibratory	Impact hammer
Wood piles 14-inch (in) diameter or less when installed via impact hammer and 36-in or less for all other installation methods	A	A	A	A	B
Concrete pile 24-in diameter/width or less in open	A	A	A	A	B
Metal pipe pile 36-in diameter or less	A	A	A	A	E
2 metal boatlift I-beams	A	A	A	A	B
Concrete slab wall- any size	A	A	A	A	B
Vinyl sheet pile- any size	A	A	A	A	B
Metal sheet pile- any size	A	A	A	A	E

### Confined Space

In Florida, we consider the confined space to be any area that has a solid object (e.g., shorelines or seawalls) within 150 ft of the pile installation site and in the U.S. Caribbean we consider confined space to be any area that has a solid object within 260 ft of the pile installation site.

	Trench and	Pilot hole (auger or	Jetting	Vibratory	Impact hammer
Wood pile 14-in diameter or less when installed via impact hammer and 36-in or less for all other installation methods	A	A	A	A	B
Concrete pile 24-in diameter/width or less (5 piles	A	A	A	A	C
Concrete pile 24-in diameter/width or less (6-10	A	A	A	A	D
Metal pipe pile 36-in diameter or less	A	A	A	A	E
2 metal boatlift I-beams	A	A	A	A	B
Vinyl sheet pile – any size	A	A	A	A	B
Concrete slab wall- any size (5 slabs or less	A	A	A	A	C
Concrete slab wall- any size (6-10 slabs installed/day)	A	A	A	A	D
Metal sheet pile- any size	A	A	A	A	E



- A. The Projects identified as A above must comply with PDCs identified for all projects in this Opinion. Specific PDCs related to noise include:**
1. All work must occur during daylight hours only (PDC AP.6).
  2. All construction personnel are responsible for observing water-related activities to detect the presence of these species and avoid them (PDC AP.7).
- B. The projects identified as B above must follow all of the conditions under A, above, **AND** also must limit the maximum number of piles installed per day to no more than 10 piles per day.**
- C. The projects identified as C above must follow all of the conditions under A, above, **AND** also must limit the maximum number of piles installed per day to no more than 5 piles per day.**
- D. The projects identified as D above must follow all of the conditions under A and B, above, **AND** also must abide by one of the noise abatement measures below, as chosen by the applicant:**
1. Bubble curtain: The bubble curtain design must adhere to the guidelines for unconfined and confined bubble curtains described in Appendix B.
  2. Temporary noise attenuation pile (TNAP) also known as a pile isolation casing: The TNAP design must be constructed of a double-walled tubular casing (a casing within a larger casing), with at least a 5-in-wide area between the casings that is dewatered to create a hollow space or 5-in wide area between the casings completely filled with closed-cell foam or other noise dampening material between the walls. The TNAP must be long enough to be seated firmly on the sea bottom, fit over the pile being driven, and extend at least 3 ft above the surface of the water.
  3. The use of any other alternative noise control method must receive prior approval by NMFS and the USACE, as described in Section 2.3.
- E. The projects identified as E are not covered under this Opinion.**

## Project Design Criteria (PDCs) Specific to Activity 6 for Boat Ramps

### **A6.1.** Activities covered by this Opinion include:

- A6.1.1. Removal or reconfiguration of existing boat ramps. The removal of upland-cut boat basins by walling off and filling them in is a type of shoreline stabilization covered under Activity 1, PDC A1.1, Section 2.2.1.
- A6.1.2. Installation of new boat ramps for motorized vessels (1) are limited in size to 40 ft wide, (2) can have up to 2 boat lanes, and (3) can be associated with no more than 50 trailered vehicle parking spaces.
- A6.1.3. New boat ramps for non-motorized vessels are limited in size to 60 ft wide.
- A6.1.4. Repair and replacement of existing boat ramps can occur within the same footprint of the existing ramp, even if the repaired or replaced boat ramp does not meet the size requirements in PDC A6.1.2 and A6.1.3. Reconfiguration of boat ramps for motorized vessels that propose to expand the footprint must meet the size limitations described in A6.1.2 (i.e., the reconfiguration must be no more than 40 ft wide and can have up to 2 boat lanes).

### **The following PDCs apply to all the activities described in PDC A6.1 above:**

- A6.2.** Excavation is limited to the area necessary for site preparation. All excavated material shall be removed to an area that is not waters of the United States, as that term is defined and interpreted under the CWA, including wetlands.
- A6.3.** All commercial or public boat ramps must have signs posted in a visible location(s) on the dock(s), alerting boaters of listed species in the area susceptible to vessel strikes or hook-and-line captures. These signs shall include contact information for the sea turtle and marine mammal stranding networks and smalltooth sawfish encounter database.  
Please visit our website  
([http://sero.nmfs.noaa.gov/protected\\_resources/section\\_7/protected\\_species\\_educational\\_signs/index.html](http://sero.nmfs.noaa.gov/protected_resources/section_7/protected_species_educational_signs/index.html)) to determine which signs are required for your area, for sign installation guidance, and to download the most current version of the signs. In addition,
  - A6.3.2. Projects within the North Atlantic right whale educational sign zone (as defined in Section 2.1.1.4) shall post the *Help Protect North Atlantic Right Whales* sign.
  - A6.3.3. Projects in the range of Gulf, Atlantic, or shortnose sturgeon also shall post the *Report Sturgeon* sign.
  - A6.3.4. We are still developing the signs to be used in the U.S. Caribbean. Once developed, those signs will be included at the website above.

- A6.4.** All commercial and public boat ramps also must install and maintain for the life of the facility monofilament recycling bins to reduce the risk of turtle or sawfish entanglement in or ingestion of marine debris. Monofilament recycling bins must:
- A6.4.1. Be constructed and labeled according to the instructions provided at <http://mrrp.myfwc.com> or any equivalent guidance for the U.S. Caribbean.
  - A6.4.2. Be maintained for the life of the facility in working order and emptied frequently so that they do not overflow.
- A6.5.** The length of new boat ramps and changes to existing boat ramps to make them longer should ensure a water depth at the end of the ramp is deep enough to minimize sediment resuspension associated with launching vessels in shallow water.
- A6.6.** New boat ramps cannot be installed on ocean beaches that are used by nesting sea turtles.

**COMMENCEMENT NOTIFICATION**

*Within ten (10) days of initiating the authorized work, submit this form via electronic mail to [saj-rd-enforcement@usace.army.mil](mailto:saj-rd-enforcement@usace.army.mil) (preferred, not to exceed 15 MB) **or** by standard mail to U.S. Army Corps of Engineers, Enforcement Section, P.O. Box 4970, Jacksonville, FL 32232-0019.*

**1. Department of the Army Permit Number:** SAJ-2021-02516(NW/GP-JLC)

**2. Permittee Information:**

Name: \_\_\_\_\_

Email: \_\_\_\_\_

Address: \_\_\_\_\_

\_\_\_\_\_

Phone: \_\_\_\_\_

**3. Construction Start Date:** \_\_\_\_\_

**4. Contact to Schedule Inspection:**

Name: \_\_\_\_\_

Email: \_\_\_\_\_

Phone: \_\_\_\_\_

\_\_\_\_\_  
Signature of Permittee

\_\_\_\_\_  
Printed Name of Permittee

\_\_\_\_\_  
Date

**SELF-CERTIFICATION STATEMENT OF COMPLIANCE**

**Permit Number: SAJ-2021-02516(NW/GP-JLC)**

Permittee's Name & Address (please print or type): \_\_\_\_\_

\_\_\_\_\_  
\_\_\_\_\_

Telephone Number: \_\_\_\_\_

Location of the Work: \_\_\_\_\_

\_\_\_\_\_

Date Work Started: \_\_\_\_\_ Date Work Completed: \_\_\_\_\_

**PROPERTY IS INACCESSIBLE WITHOUT PRIOR NOTIFICATION: YES \_\_\_\_\_ NO \_\_\_\_\_**  
**TO SCHEDULE AN INSPECTION PLEASE CONTACT \_\_\_\_\_**  
**AT \_\_\_\_\_**

Description of the Work (e.g. bank stabilization, residential or commercial filling, docks, dredging, etc.): \_\_\_\_\_

\_\_\_\_\_  
\_\_\_\_\_

Acreage or Square Feet of Impacts to Waters of the United States: \_\_\_\_\_

Describe Mitigation completed (if applicable): \_\_\_\_\_

\_\_\_\_\_  
\_\_\_\_\_

Describe any Deviations from Permit (attach drawing(s) depicting the deviations):

\_\_\_\_\_  
\_\_\_\_\_

I certify that all work, and mitigation (if applicable) was done in accordance with the limitations and conditions as described in the permit. Any deviations as described above are depicted on the attached drawing(s).

\_\_\_\_\_  
Signature of Permittee

\_\_\_\_\_  
Full Name of Permittee (printed or typed)

\_\_\_\_\_  
Date

**DEPARTMENT OF THE ARMY PERMIT TRANSFER REQUEST**

**DA PERMIT NUMBER: SAJ-2021-02516(NW/GP-JLC)**

When the structures or work authorized by this permit are still in existence at the time the property is transferred, the terms and conditions of this permit will continue to be binding on the new owner(s) of the property. Although the construction period for works authorized by Department of the Army permits is finite, the permit itself, with its limitations, does not expire.

To validate the transfer of this permit and the associated responsibilities associated with compliance with its terms and conditions, have the transferee sign and date below and mail to the U.S. Army Corps of Engineers, Enforcement Section, Post Office Box 4970, Jacksonville, FL 32232-0019 or submit via electronic mail to: [SAJ-RD-Enforcement@usace.army.mil](mailto:SAJ-RD-Enforcement@usace.army.mil) (not to exceed 15 MB).

\_\_\_\_\_  
(TRANSFEREE-SIGNATURE)

\_\_\_\_\_  
(SUBDIVISION)

\_\_\_\_\_  
(DATE)

\_\_\_\_\_  
(LOT)

\_\_\_\_\_  
(BLOCK)

\_\_\_\_\_  
(NAME-PRINTED)

\_\_\_\_\_  
(STREET ADDRESS)

\_\_\_\_\_  
(MAILING ADDRESS)

\_\_\_\_\_  
(CITY, STATE, ZIP CODE)