

to seal joints, seams and other areas where water entry must be stopped.

- C. Elastic Sealant shall be ELASTOFILL as manufactured by **Martin Mathys, S.A.**, nationally distributed by **ACT-Martco**, Elmsford, New York. The waterproof sealant is discharged from caulking tube. ELASTOFILL is a one-part, water-borne acrylic malleable paste which, after complete cure, forms a highly elastic, rubber-like, 100% waterproof joint sealant, showing a permanent elasticity, complete impermeability to water, a resistance to alkaline substances, resistance to aging and long term weathering as well as resisting temperatures up to 230 degrees F. without sagging.
- D. Top coat shall be PRT COATING as manufactured by **Martin Mathys, S.A.**, nationally distributed by **ACT-Martco**, Elmsford, New York. PRT COATING is a one part solvent acrylic finish coat, non-saponifiable, that can be applied directly to new concrete or used as a top coat for DAKFILL roof finishes.
- E. Physical Properties and MSDS sheets are available from manufacturer.

## 2.04 COLORS

- A. Color of each product for each application shall be selected by the OWNER and provided to the CONTRACTOR prior to his placing order for product. The color selection shall be from standard colors by the manufacturer. The product shall be delivered to the Contractor already color mixed and properly identified. CONTRACTOR shall mix product thoroughly to insure uniform color throughout.

## PART 3 EXECUTION

### 3.01 INSTALLATION

- A. Work for this project shall be carried out in accordance with all Local, State, Federal Laws and Regulations with the most restrictive laws or regulations being followed. CONTRACTOR shall comply with all ordinances regarding dust, debris and noise and shall be required to adhere to same. Permits, inspections, and appropriate certificates as required by the work under this contract shall be obtained by and paid for by the CONTRACTOR.
- B. Coating and membrane system must be installed by an applicator familiar with the coating or membrane system as well as under the guidance of the manufacturer. Inspections will be made by the manufacturer's authorized technical consultant throughout the Project and final inspections will be conducted by the regional or national technical consultants of the manufacturer with the CONTRACTOR. CONTRACTOR shall coordinate with the manufacturer's technical inspector for times and applications phase terminations so that inspections may occur without delaying the next phase of the application. A final inspection will ascertain that the Coating or Membrane System has been installed in accordance with the specifications for the project. No deviations will be allowed from the manufacturer's specifications, unless these changes are submitted and approved in advance by owner's agent in conjunction with the manufacturer's technical consultant prior to the start of the project application.
- C. CONTRACTOR shall familiarize himself with all aspects of the job prior to providing his bid proposal for the project. He shall proceed with the work in an orderly and prompt manner upon authorization. He shall commence with the work as required minimizing noise and other disturbances to the normal operation of the office facility. He shall remove all debris immediately from the area so that the wind does not carry the debris beyond the work area.

## **PART 3 APPLICATION**

### **3.01 METAL STANDING SEAM ROOF**

#### **A. SURFACE PREPARATION**

1. Pressure wash entire surface with 3000 psi at 180 degrees F. hot water and Dirt Killer DK Spinner Tip or Turbo-tip at point blank range. As soon as surface is dry, coating work can begin.
2. Hand scrape or wire brush any heavy rust areas, catching any hazardous particles.
3. Feather edge around the old coating to relieve the pressure of lift off.
4. Remove excess oil and grease (if any) with TSP or other detergents. As soon as surface is dry, coating work can begin.

#### **B. APPLICATION**

1. ELASTOFILL is applied over all fasteners and along panel joints and seams.
2. Six inch reinforcing mesh and NOXYDE at 13 mils wet is applied to all open joints, over copings, roof plane connections where there is movement and at transition and along edges as required to totally seal the roof, yet allow it to move.
3. NOXYDE (Color #1) diluted by 33% water is sprayed as a fog coat over the entire standing seam metal roof and fascia surface at a 2 dry mill thickness for adhesion.
4. NOXYDE (Color #2) is sprayed with airless spray at 13 mils wet over entire standing seam metal roof and fascia surface.
5. PEGACRYL (Final Color) is sprayed as the final coat with airless spray at 5 wet mils over the entire standing seam metal roof and fascia surface.
6. Final PEGACRYL coat can be sprayed over first coat after overnight drying. If more than two (2) days elapse between the first and second coats, light water wash is recommended to remove dirt and salt contamination of the first coat.

### **3.02 BUILT UP ROOF**

#### **C. PREPARATION**

1. Remove all water damaged insulation and replace it in a proper manner to original roof height. All surfaces shall be sound, clean and dry before proceeding with the application.
2. Chip off any alligatored surfaces to leave a smooth work surface. Remove all loose and damaged paper. Seal up any cracks, holes and flashing areas to make them watertight. Use star cut repair on any blisters.
3. Sweep up all dirt AND DEBRIS in work area before pressure wash.
4. Verify that all roof drains, gutters and leaders are not clogged prior to hot water pressure wash. Pressure wash the area to be repaired with 180 degrees F. hot water minimum pressure of 1500 psi to eliminate any salts and bacteria and allow to dry thoroughly for at least 24 hours before proceeding with the work.
5. In areas of ponding water in the work area, scrub vigorously using one (1) part chlorine and three (3) parts water to kill embedded microorganisms in the work surface. TSP can be added to this mix to remove oil, grease, dirt and other latents. These areas shall be re-rinsed before application.

#### **D. APPLICATION**

1. PARAPET WALLS: Starting at the fascia of the metal coping, use the flashing mesh and DAKFILL to bridge these joints, seal them up, yet allow them to move and flex in the future.

DAKFILL membrane can be extended with roller or brush, over the inside area of the parapet wall using flashing mesh and extended at least 12 inches onto roof deck. ELASTOFILL should be applied into the cracks as filler material before mesh and DAKFILL are applied.

2. REGLET FLASHING: Bridging mesh and DAKFILL is applied over the REGLET Flashing on the wall, making a flexible "bridge" over this area.
3. COVE AREA OF ROOF: Using the 18-inch wide mesh, coating the cove area of the roof shall be completed and cut in prior to starting the spray application of DAKFILL. Work area shall extend at least 12 inches onto roof deck.
4. DRAIN and SCUPPER: Shall be flashed with reinforcing mesh and DAKFILL. The work shall be cut in accordance with manufacturer's details. Drain shall be flashed into the throat of the drain and up onto at least 12 inches of the roof deck.
5. MECHANICAL EQUIPMENT, PENETRATIONS, ETC.: DAKFILL with flashing mesh shall be applied around all penetrations using scissors to cut scalloped legs into the mesh so it will free-form itself around the penetration and reinforce the membrane in the joint area. ELASTOFILL should be added to form a rubbery bumper right in the 90 degree angle of this work. DAKFILL and mesh can be applied directly and immediately over the ELASTOFILL. Work should extend at least 12 inches onto roof deck and over top of base. All rusted areas should be coated with one coat of NOXYDE at 13 wet mils.
6. Once the flashing and specialty work is completed, the first coat of DAKFILL is applied. Apply DAKFILL thru 48 inch mesh, using roller application onto deck surface. First coat is applied so that all holes in mesh are filled up. Let dry overnight.
7. Apply second coat of DAKFILL to obliterate mesh, and let dry 48 hours. This can be done with roller or airless spray (21-26 tip) and left to cure overnight.
8. Apply sealer coat of White PRT over entire flat surface at 3-4 wet mils thickness.

#### PART 4 WORKMANSHIP

- A. The Contractor shall be responsible for the cleanliness of his coating operations and shall use covers and masking tape to protect the new and existing material not intended to be coated whenever such covering is necessary, or if requested by the Owner. Any coatings identified for removal shall be carefully removed without damage to any finished coatings or surface. If damage does occur, the entire surface, adjacent to and including the damaged area, shall be re-coated without visible lapmarks and without additional cost to the Owner.
- B. Coating found defective shall be removed and re-coated as required by the Owner. Before final acceptance of the Work, damaged surfaces shall be cleaned and re-coated as directed by the Owner.
- C. CLEANUP: The buildings and other Work areas shall be kept free from accumulation of waste material and rubbish caused by the work. At the completion of the coating work, all tools, equipment, scaffolding, surplus materials, and all rubbish around the building(s) shall be removed and the work area left broom clean unless otherwise specified.

END OF SECTION

## SECTION 09920 SEWPERCOAT SURFACING SYSTEM

### PART 1 GENERAL

#### 1.01 SCOPE OF WORK

- A. The Contractor shall furnish all labor, materials, equipment and incidentals required to install and test the SewperCoat surface system and appurtenances complete for the rehabilitation of the lift stations listed in the Specifications and as shown on the Drawings.
- B. The Contractor shall accurately field measure each individual lift station. The Contractor is reminded that each existing sewer field measurement shall be the sole responsibility of the Contractor.
- C. The purpose of this Section is to obtain a dense and durable fiber reinforced concrete liner for the repair of voids for the restoration of structural integrity, and to provide corrosion resistance to concrete or any other masonry material.

#### 1.02 RELATED WORK

- A. Bypass pumping, surface cleaning, and removal and off-site disposal of rubble is the responsibility of the General Contractor.

#### 1.03 SUBMITTALS

- A. Submit to the Engineer, shop drawings and schedules of all surface coating systems and appurtenances required. Submit design data and specification data sheets listing all parameters used in the surface coating system.
- B. Submit to the Engineer, within 30 days of the effective date of the Agreement, the name of the surface coating supplier, a list of materials to be furnished, and the qualifications (per 1.05 A) of the application contractor..

#### 1.04 REFERENCE STANDARDS

- A. American Society for Testing and Materials (ASTM)
  - ASTM C882 Test Method for Bond Strength of Epoxy-Resin Systems Used with Concrete
  - ASTM D2247 Practice for Testing Water Resistance for Coatings in 100% Relative Humidity
- B. For casted specimens:
  - ASTM 666 Test Method for Freeze Thaw - 600 Cycles (No Damage)
  - ASTM C596 Test Method for Shrinkage - 0% at 95% R.H.
  - ASTM C109 Test Method for Compressive Strength - 24 hr., 8,000 psi; 28 day, 9,000 psi.
  - ASTM C348 Test Method for Flexural Strength - 24 hr., 1,300 psi; 28 day, 1,400 psi.
- C. Where reference is made to one of the above standards, the revision in effect at the time of

bid opening shall apply.

#### **1.05 QUALIFICATIONS**

- A. The Contractor performing the surface coating work shall be fully qualified, experienced a minimum of seven years and equipped to complete this work expeditiously and in a satisfactory manner. The Contractor shall submit the following information to the Engineer for review and approval before any surface coating work is performed.
1. The number of years of experience in performing this type of specialized work must be seven years minimum.
  2. Name of the surface coating manufacturer and supplier for this work and previous work listed below. The Contractor shall be an approved installer as certified and licensed by the manufacturer and equipment supplier.
  3. A list of clients that the Contractor has performed this type of work.
    - a. The list shall contain names and telephone numbers of persons who can be called to verify previous satisfactory performance.
    - b. Installation dates and a description of the actual work performed.
    - c. The manufacturer shall provide an installation list of his product used for similar sewer lift station rehabilitation projects. The list shall provide the same information as required in paragraphs 3.a and 3.b above.
- B. The Owner reserves the right to approve or disapprove the Contractor, based on the submitted qualifications.

#### **1.06 GUARANTEE**

- A. All surface coatings shall be guaranteed by the Contractor for a period of three years from the date of acceptance. During this period, all defects discovered in the surface coating as determined by the Owner's Engineer, shall be repaired or replaced in a satisfactory manner at no cost to the Owner.

#### **1.07 QUALITY ASSURANCE**

All surface coating products shall be from a single manufacturer. The supplier shall be responsible for the provisions of all test requirements specified in ASTM Standards as applicable.

#### **1.08 DELIVERY, STORAGE AND HANDLING**

- A. Care shall be taken in shipping, handling and placing to avoid damaging. Extra care will be necessary during cold weather construction. Any product damaged in shipment shall be replaced as directed by the Engineer.
- B. Any product showing deterioration, or which has been exposed to any other adverse storage condition that may have caused damage, even though no such damage can be seen, shall be marked as rejected and removed at once from the work.

#### **PART 2 EQUIPMENT**

- A. The equipment shall be clean and free of any hydrated or unhydrated Portland Cement to prevent acceleration of SewperCoat 2000 HS Regular.

- B. Shotcrete shall be thoroughly mixed in machine before being dispatched to hopper. At this time, if specified, the addition of fibers (polypropylene, alkali resistant, nylon steel, etc.) should be conducted as well as predampening of SewperCoat (.5% by weight).
- C. Water must be clean and potable. Warmer water may be used to accelerate setting time during "cold" temperatures.
- D. Each batch should be entirely discharged before recharging begins.
- E. The mixer should be cleaned thoroughly to remove all adherent materials from the mixing vanes and from the drum at regular intervals.
- F. Mixer and predampened material that has stood 45 minutes during warm weather months shall be discarded.
- G. Gauged water (predampen + nozzle) shall not exceed 0.60 gallons (U.S.) per 50 lbs. per bag of SewperCoat.

### **PART 3 EXECUTION**

#### **3.01 INSTALLATION**

- A. The Contractor shall clean each lift station and shall dispose of any resulting material.
  - 1. Use a high power jet wash at a minimum of 4000-6000 psi water pressure with a 20 percent muriatic acid wash to remove all dust, laitance, biological growths, grease, oil, paint, or other surface contaminants or coatings.
  - 2. Coatings that cannot be removed shall be profiled via sand blasting to rough the surface sufficient to obtain and insure adequate bonding.
  - 3. The Contractor shall completely remove all coated, scaly or unsound masonry material to achieve a good bonding surface.
  - 4. In order to insure a good bond, the Contractor shall water blast the surface thoroughly so that it is moistened with water prior to application of SewerCoat 2000 HS Regular.
- B. The Contractor shall conduct a visual inspection of each lift station after it is cleaned. He shall remove all loose mortar and rubble, and prepare each station to receive surface coating as necessary by restoring walls and floors where required. All interior surfaces shall be prepared for surface coating as recommended by the manufacturer.
  - 1. All cracks and other voids must be repaired and filled with suitable non-shrinking cements, sealants, or grouts. No latex materials will be allowed or resaturating grout materials.
  - 2. All surfaces shall be clean and structurally sound prior to the application of the surface coating.
  - 3. No separate payment shall be made for any preparatory work required prior to application of the surface coating.
- C. The Contractor shall notify the Project Manager and Jim Marble, (941) 792-8811, ext. 5277 at least 48 hours in advance, giving the date, start time and estimated completion time for the work being conducted.
- D. The Contractor shall provide bypass pumping of sewage flows (as required) where and when the rehabilitation work is being performed.

- E. "Shooting" shall be from an angle as near perpendicular to the surface as practicable.
- F. If flow of material at the nozzle is not uniform and slugs, sand spots, or wet sloughs result, the nozzleman shall direct the nozzle away from the work until the faulty conditions are corrected.
- G. Shotcreting shall be suspended if:
  - 1. Air velocity separates the cement from the aggregate at the nozzle.
  - 2. Temperature approaches freezing and the newly placed shotcrete cannot be protected.
- H. Shotcrete shall be applied in one or more layers to such total thickness as required to restore the area as detailed over the original lines of the adjoining surface, unless otherwise specified.
- I. To prevent concrete "tearing", a gunned finish is appropriate. However, once material has been applied, it can immediately be trowelled or "wet" brushed.
- J. In most instances, keeping doors closed should suffice for moist curing. However, the use of a curing compound may be desirable.
- K. Once material is applied, caution should be taken to minimize exposure of direct sunlight and strong air movement. If this is the case, a curing compound (ASTM C309) should be applied after installation in addition to keeping doors closed. This is used for minimizing rapid evaporation of moisture.
- L. Material shall be spray applied at a minimum of one-half inch thickness. This may be applied in one application.
- M. Rebound materials shall not be reused.

### 3.02 FIELD TESTING AND ACCEPTANCE

- A. Field acceptance of coating shall be based on the Engineer's evaluation of the proper surfacing of the lift station and the appropriate installation and curing test data along with review of the inspections.
- B. The coating shall provide a continuous surface with uniform thickness throughout the lift stations.

If the thickness of the coating is not uniform or is less than specified, it shall be repaired or replaced at no additional cost to the Owner.

- 1. The Engineer will measure the coating cured thickness from a specimen retrieved by the Contractor. Retrieve the specimen by physically cutting through the surfacing (by drilling or coring). There will be up to three thickness measurement locations in each lift station. A suitable non-destructive type of thickness measurement may also be used.
- 2. All the coating thickness measurement locations shall be repaired by the Contractor in accordance with the manufacturer's recommendations. These repairs shall be included in the three year guarantee.

- C. There shall be no cracks, voids, pinholes, uncured spots, dry spots, lifts, delaminations or other type defects in the lift station.
- D. If any defective coating is discovered after it has been installed, it shall be repaired or replaced in a satisfactory manner within 72 hours and at no additional cost to the Owner. This requirement shall apply for the entire three year guarantee period.

END OF SECTION



## SECTION 09970 SURFACE PROTECTION SPRAY SYSTEM

### PART 1 GENERAL

#### 1.01 SCOPE OF WORK

- A. The Contractor shall furnish all labor, materials, equipment and incidentals required to install and test the coating system complete and ready for operation for the structures listed in the specifications and as shown on the Drawings.
- B. The work includes coating of all surfaces as shown and specified on the Drawings. This includes, but is not limited to stairs, walls, floors, concrete divider, concrete slabs, manholes wet wells, and all other work obviously required to be coated unless otherwise specified herein or on the Drawings. The omission of minor items in the Schedule of Work shall not relieve the Contractor of his obligation to include such items where they come within the general intent of the Specification as stated herein.

#### 1.02 RELATED WORK

- A. Bypass pumping is the responsibility of the General Contractor.
- B. Concrete surface cleaning in each lift station is the responsibility of the General contractor.
- C. Removal and offsite disposal of rubble is the responsibility of the General Contractor.

#### 1.03 SUBMITTALS

- A. Submit to the Engineer shop drawings and schedules of all surfacing systems and appurtenances required. Submit design data and specification data sheets listing all parameters used in the surfacing system design and thickness calculations based on applicable provisions of ASTM.
- B. Submit to the Engineer the name of the surfacing supplier, a list of materials to be furnished, and the qualification (per 1.05 A) of the application contractor.

#### 1.04 REFERENCE STANDARDS

- A. American Society for Testing and Materials (ASTM)  
  
ASTM D-638  
ASTM D-790
- B. Where reference is made to one of the above standards, the revision in effect at the time of bid opening shall apply.

#### 1.05 QUALIFICATIONS

- A. The Contractor performing the surfacing work shall be fully qualified, experienced a minimum of seven years and equipped to complete this work expeditiously and in a satisfactory manner. The Contractor shall submit the following information to the Engineer for review and approval before any surfacing work is performed.

1. The number of years of experience in performing this type of specialized work must be seven years minimum.
  2. Name of the surfacing manufacturer and supplier for this work and previous work listed below. The Contractor shall be an approved installer as certified and licensed by the surfacing manufacturer and equipment supplier.
  3. A list of clients that the Contractor has performed this type of work.
    - a. The list shall contain names and telephone numbers of persons who can be called to verify previous satisfactory performance.
    - b. Installation dates and a description of the actual work performed.
    - c. The surfacing manufacturer shall provide an installation list of his product used for similar sewer rehabilitation projects. The list shall provide the same information as required in paragraphs 3.a and 3.b above.
- B. The Owner reserves the right to approve or disapprove the Contractor, based on the submitted qualifications.

#### 1.06 GUARANTEE

All surfacing shall be guaranteed by the Contractor for a period of five years from the date of acceptance. During this period, all defects discovered in the surfacing, as determined by the Owner's Engineer, shall be repaired or replaced in a satisfactory manner at no cost to the Owner, this shall include, but is not limited to, all work and costs associated with the shut down of any pump stations and all bypass operations needed for the proper repairs to be made.

#### 1.07 QUALITY ASSURANCE

- A. All surfacing products shall be from a single manufacturer. The supplier shall be responsible for the provisions of all test requirements specified in ASTM Standards D-638 and D-790 as applicable.
- B. The Contractor shall employ specialty workers who have proven ability to perform the Work included herein. This will consist of a minimum of two years or two project experiences installing this product. This is a requirement for each and every employee.

#### 1.08 DELIVERY, STORAGE AND HANDLING

- A. Care shall be taken in shipping, handling and placing to avoid damaging. Any material damaged in shipment shall be replaced as directed by the Engineer.
- B. Any material showing deterioration, or which has been exposed to any other adverse storage condition that may have caused damage, even though no such damage can be seen, shall be marked as rejected and removed at once from the work.

### PART 2 PRODUCTS

#### 2.01 GENERAL

- A. The material sprayed onto the surface shall be a urethane resin system formulated for the application within a sanitary sewer environment. The urethane will exhibit suitable corrosion resistance to corrosive gases and fluids found within domestic sanitary sewage. Unless dictated by varying effluent, the spray system shall be a urethane and exhibit the cured physical strengths specified herein.
- B. When cured, the surface coating shall form a continuous, tight-fitting, hard, impermeable surfacing data which is suitable for sewer system service and chemically resistant to any chemicals or vapors normally found in domestic sewage.
- C. The surface shall be an integral part of the structure being rehabilitated after being placed and cured. The surface shall cover the complete interior of the existing structure. The surface shall provide a continuous watertight seal or barrier.
  - 1. The surface shall effectively seal the interior surfaces of the structure and prevent any penetration or leakage of groundwater infiltration.
  - 2. Provide water resistance data on surface based on ASTM Standards.
  - 3. The surface shall be compatible with the thermal conditions of existing sewer lift stations and manholes. Surface temperature will range from 30 to 80 degrees F. Provide test data on thermal compatibility based on ASTM Standards.

**2.02 MATERIALS**

- A. Approved materials include Spraywall polyurethane by Sprayroq or Aquatapoxy A-6 or Raven 405 epoxy by Raven Lining Systems or Polyurethane Lining System by Protective Liner Systems.
- B. Polyurethane spray application shall comply with the following specifications:

The cured urethane system shall conform to the minimum physical standards, as listed below. The long-term data is for a 50-year design life of the process.

<u>Cured Urethane</u>	<u>Standard</u>	<u>Long-Term Data</u>
Tensile Stress	ASTM D-638	5,000 psi
Flexural Stress	ASTM D-790	10,000 psi
Flexural Modulus	ASTM D-790	550,000 psi

- C. Epoxy spray application shall be 100% VOC free / 100% solids.

**PART 3 EXECUTION**

**3.01 SURFACE PREPARATION**

- A. The contractor shall clean each structure and shall dispose of any resulting material.
- B. All contaminants including: oils, grease, incompatible existing coatings, waxes, form release, curing compounds, efflorescence, sealers, salts, or other contaminants shall be removed.

- C. All concrete or mortar that is not sound or has been damaged by chemical exposure shall be removed to a sound concrete surface or replaced.
- D. Surface preparation method(s) should be based upon the conditions of the substrate, service environment and the requirements of the protective coating to be applied.
- E. Surfaces to receive protective coating shall be cleaned and abraded to produce a sound surface with adequate profile and porosity to provide a strong bond between the protective coating and the substrate. Generally, this can be achieved with a high pressure water cleaning using equipment capable of 5,000 psi at 4 gpm. Other methods such as abrasive blasting, shotblasting, grinding, scarifying or acid etching may also be used. Detergent water cleaning and hot water blasting may be necessary to remove oils, grease or other hydrocarbon residues from the concrete. Whichever method(s) are used, they shall be performed in a manner that provides a uniform, sound clean neutralized surface that is not excessively damaged.
- F. Infiltration shall be stopped by using a material which is compatible with and is suitable for topcoating with the specified protective coating.
- G. The area between the manhole and the manhole ring and any other area that might exhibit movement or cracking due to expansion and contraction, shall be grouted with a flexible grout or gel before surface coating spray application.
- H. All surfaces should be inspected by the Inspector during and after preparation and before the repair material is applied.
- I. No separate payment shall be made for any preparatory work required prior to application of the surface coating.

### 3.02 INSTALLATION

- A. The Contractor shall notify the Project Manager at least 48 hours in advance, giving the date, start time and estimated completion time for the work being conducted.
- B. The Contractor shall provide bypass pumping of sewage flows (as required) where and when the rehabilitation work is being performed. No flows will be permitted in the structure until the spray coating has properly cured to the manufacturer's specifications.
- C. The installation of the surface coating shall be in complete accordance with the applicable provisions of ASTM and the manufacturer's specifications. A representative of the manufacturer shall be present during the actual installation.
  - 1. Prior to placing the surface coating, the manufacturer's representative must approve the surface preparation work and installation conditions including temperatures.
  - 2. All surfaces shall be sufficiently smooth and even, to ensure good flow handling characteristics when complete.
  - 3. All surfaces shall have the surface coating applied to the required thickness by spray application.
- D. Application procedures shall conform to the recommendations of the protective coating manufacturer, including material handling, mixing, environmental controls during application,

safety, and spray equipment.

- E. The spray equipment shall be specifically designed to accurately ratio and apply the specified protective coating materials and shall be regularly maintained and in proper working order.
- F. The protective coating material must be spray applied by a Certified Applicator of the protective coating manufacturer.
- G. Polyurethane spray application shall be applied such that all surfaces shall be coated in accordance with the manufactures recommended thickness but not be less than 125 mils.
- H. Epoxy spray application shall be applied such that all surfaces shall be coated in accordance with the following:

- 1. Specified surfaces shall be coated by spray application of a moisture tolerant, solvent-free, 100% solids, epoxy protective coating as further described herein. Spray application shall be to a minimum wet film thickness in accordance with the following table:

Concrete, New/Smooth	80-100 mils for immersion, 60-80 mils for atmospheric, splash and spill exposure
Concrete, Rough	100-125+ mils
Masonry/Brick	125-150+ mils
Steel	16-80 mils for immersion, 16-40 mils for atmospheric, splash and spill exposure; also profile dependent
Fiberglass Systems	40-60 mils tack coat, 9 oz/yd <sup>2</sup> fabric, 40-60 mils top coat. Varies with circumstances

- 2. Airless spray application equipment approved by the coating manufacturer shall be used to apply each coat of the protective coating. Air assisted spray application equipment may be acceptable, especially for thinner coats (<10 mils), only if the air source is filtered to completely remove all oil and water.
- 3. If necessary, subsequent topcoating or additional coats of the protective coating should occur as soon as the basecoat becomes tack free, ideally within 12 hours but no later than the recoat window for the specified products. Additional surface preparation procedures will be required if this recoat window is exceeded.

### 3.03 FIELD TESTING AND ACCEPTANCE

- A. Field acceptance of surface coatings shall be based on the Engineer's evaluation of the proper surfacing of the structure and the appropriate installation and curing test data along with review of the structure inspections.
- B. The surface coatings shall provide a continuous monolithic surfacing with uniform thickness throughout the structure interior. If the thickness of the coating surface is not uniform or is less than specified, it shall be repaired or replaced at no additional cost to the Owner.

- 1. The Engineer will measure the surface cured thickness from a specimen retrieved by

the Contractor. The Contractor shall retrieve the specimen by physically cutting through the surfacing (by drilling or coring). There will be up to three thickness measurement locations in each structure. A suitable non-destructive type of thickness measurement may also be used.

2. All the surface coating thickness measurement locations shall be repaired by the Contractor in accordance with the manufacturer's recommendations. These repairs shall be included in the five year surface coating guarantee.
- C. All pipe connections shall be open and clear.
  - D. There shall be no cracks, voids, pinholes, uncured spots, dry spots, lifts, delaminations or other type defects.
  - E. If any defective surface coating is discovered after it has been installed, it shall be repaired or replaced in a satisfactory manner within 72 hours and at no additional cost to the Owner. This requirement shall apply for the entire five year guarantee period.

**END OF SECTION**

## SECTION 10520 FIRE EXTINGUISHERS

### PART 1 GENERAL

#### 1.01 SCOPE OF WORK

- A. Furnish all labor, materials, equipment and incidentals required and install fire extinguishers and the requisite wall mounting brackets at the locations shown on the Contract Drawings.

### PART 2 PRODUCTS

#### 2.01 MATERIALS

- A. Fire extinguishers shall be 10 pound capacity, dry chemical type, rated for A, B and C Class fires. Extinguishers shall be red enamel painted steel cylinders with indicating gauge and shall be as manufactured by Larsen's Manufacturing Company, Fyr-Fyter Company, or County Fire Equipment Company.
- B. Brackets for wall mounting, as manufactured by extinguisher manufacturer, shall be furnished for all fire extinguishers.

### PART 3 EXECUTION

#### 3.01 INSTALLATION

- A. Fire extinguishers and brackets shall be wall mounted.
- B. Mount brackets 4 feet 6 inches above finish floor with expansion bolts or toggle bolts into concrete blocks.

END OF SECTION

## SECTION 11210 VERTICAL TURBINE PUMPS

### PART 1 GENERAL

#### 1.01 SCOPE OF WORK

- A. Furnish and factory test two (2) vertical turbine pumps of the sizes and capacities hereinafter specified.

#### 1.02 MANUFACTURERS' QUALIFICATIONS

- A. The pumps shall be the products of manufacturers who have a minimum provable history of ten (10) years in the manufacturing and servicing of pumps of the type, size, and capacity hereinafter specified.

#### 1.03 APPLICATION

- A. The pumps will be used to pump a liquid consisting of wastewater effluent having a specific gravity of 1.0. The pumped liquid will be at ambient temperature (nominally, 76°F).
- B. The pumps will be used in a variable speed pumping system application.

#### 1.04 OPERATING CONDITIONS

- A. The pumps shall be able to operate under the following environmental conditions without modification or derating:
1. Temperature: 0 to 40°C.
  2. Altitude: Up to 3,300' above sea level.
  3. Humidity: 0 to 95%, non-condensing.
  4. Location: Wastewater Treatment Facility.

#### 1.05 PUMP TESTING

- A. Prior to shipment, the pumps shall be subjected to certified factory tests, both hydrostatic and vibrational, in accordance with the standards of the Hydraulic Institute.
- B. The Owner may, at his option, have an authorized representative(s) witness the factory pump tests. The manufacturer/supplier shall include in his price an amount sufficient to reimburse the Owner for all reasonable out-of-pocket expenses incurred by the Owner's representative(s) to witness the factory tests. If multiple visits are necessary, the Owner shall deduct the additional expenses incurred from the payments due the manufacturer/supplier.
- C. The Owner shall be notified of the factory testing at least ten (10) working days prior to the tests being conducted. Such notification shall include the date, time, and location of the tests. Additionally, the notification of testing shall include both a list of the testing procedures to be followed and a list of the test equipment to be used.
- D. All meters, gauges, and other test equipment used must be calibrated within thirty (30) days prior to the testing and certified copies of the calibration data shall be furnished to the Owner.
- E. After the factory testing is completed, the Owner may, at his option, seal any and all devices used in the testing and ship said device(s) to an independent testing laboratory for calibration check



tests. The cost of such testing shall be borne by the manufacturer.

- F. Each pump shall be tested through a range of flows and head/capacity/brake horsepower/efficiency curves plotted. During each test, the pump shall be run at each head condition for a period of time sufficient to accurately determine discharge, head, power input, and efficiency. During the tests, the overall pump efficiency shall be determined at the "design point".

#### 1.06 SUBMITTALS

- A. The pump manufacturers shall furnish the Owner with five (5) sets of pump documents for review and approval. If any manufacturer requires more than two (2) sets be returned for his own use, then he should increase the number of submittal sets accordingly.
- B. The pump submittal documents shall include, but not necessarily be limited to, the following:
  - 1. Certified shop and installation drawings which show all important details of construction, including dimensions, weights, and anchor bolt locations and size.
  - 2. Descriptive literature, bulletins, and/or catalogs of the pump.
  - 3. Data on the characteristics and performance of each pump. Data shall include guaranteed performance curves based on actual factory testing of a similar pump(s). Curves shall clearly show compliance with the specified requirements for head, capacity, efficiency, etc. Curves shall be submitted on 82 x 11" sheets plotted to as large a scale as is practical.
  - 4. A complete bill of materials listing all parts, assemblies, subassemblies, bearing, gaskets, etc.
  - 5. A list of recommended spare parts to be supplied by the pump manufacturer. If not already included on his recommended spare parts list, the manufacturer shall also supply the following:
    - a. Two (2) stuffing box bushings.
    - b. Three (3) sets of packing.
    - c. Three (3) sets of gaskets.
    - d. Two (2) sets of bowl bearings.

#### 1.07 SPARE PARTS

- A. The pump manufacturers shall furnish the spare parts as set forth in Item 1.06.B.5 above.
- B. The spare parts shall be furnished in containers which are clearly identified with indelible markings as to contents. Each container shall be packaged with its contents protected for prolonged storage.

#### 1.08 WARRANTY

- A. Each manufacturer shall warrant that his respective pump is free from defects in all materials and workmanship for a period of two (2) years from date of final acceptance, or for the duration of the manufacturer's standard warranty, whichever period is longer.
- B. During the warranty period, any and all covered defects shall be corrected by the respective pump manufacturer solely at his own expense with no cost to the Owner.

### PART 2 PRODUCTS

#### 2.01 VERTICAL TURBINE PUMPS

A. GENERAL

1. The pumps shall be their respective manufacturer's standard model designed and constructed using the best industry practices and methods with a proven ability to operate satisfactorily under conditions similar to those specified.
2. The pumps shall be designed and built for 24-hour a day continuous service at any and all points within the specified operating range without any overheating, cavitation, excessive vibration, or strain.
3. The pumps shall be suitable for variable speed pumping applications.
4. All necessary foundation bolts, plates, nuts, and washers shall be fabricated from 316 stainless steel and shall be furnished by the pump manufacturer.
5. Each pump shall be furnished with a permanently attached stainless steel nameplate stamped with the manufacturer's name, the rated capacity, head, speed, and other pertinent data.
6. All rotating parts shall be dynamically balanced both mechanically and hydraulically so as to operate throughout the design range without excessive thrust, vibration, or noise. All exposed or readily accessible rotating parts shall be covered by guards or screens to prevent injury to personnel.

B. PUMP CONSTRUCTION

1. Capacity: The pump shall have maximum pumping GPM & TDH capacity as noted on the plans.
2. Fluid: The pump shall be used to pump a wastewater effluent liquid having a specific gravity of 1.0 at a nominal ambient temperature of 76°F.
3. Drive Motor: The pump shall be coupled to and driven by a vertical hollow shaft squirrel cage induction motor. The screw (threaded) type coupler shall be furnished by the motor manufacturer.
4. Discharge Head: The pump discharge head shall be as shown on the plans, shall be of fabricated steel construction, shall have a flat faced flanged discharge connection, shall incorporate a suitable pump support baseplate, shall be furnished with an integral fabricated steel mounting ring, and shall be fitted with a bleed-off type stuffing box having a bronze bearing, a bronze cage ring, a split brass packing gland, and not less than four (4) rings of teflon filament or the manufacturer's standard packing; specifically, graphited yarn packing will not be acceptable under this Specification.
5. Pump Column: The pump column shall have a diameter and length as shown on the plans, shall be flanged on both ends, shall be fabricated from Schedule 40 steel, and fitted with cast iron bearing retainers as required to maintain proper alignment of the line shaft.
6. Shafts: The head shaft, line shaft, and bowl shaft shall have a minimum diameter as shown on the plans, shall be fabricated from 416 stainless steel, and shall be fitted with bronze bearings as required. The line shaft shall be joined to the head shaft and the bowl shaft with 416 stainless steel screw (threaded) type couplings.
7. Bowls:
  - a. The pump bowls shall be constructed of Class 30 cast iron and shall be fitted with bronze bearings. The bowls shall be equipped with wear rings fabricated from a nickel-aluminum bronze alloy.
  - b. The pump impellers shall be the enclosed type, shall be of bronze construction, shall be attached to the shaft with steel taper lock fittings, and shall be hydraulically balanced to minimize drive motor thrust loading. Impeller diameter (min./max.) shall be as shown on the plans.
  - c. The suction case shall be of the bell type, shall be fabricated from cast iron, shall be fitted with a bronze bearing, shall have a brass or bronze sand collar, shall

terminate in a steel pipe plug, and shall be covered with a galvanized steel strainer.

8. Pump Coating: Except for the interior of the bowls which are to be Heresite lined, all portions of the pump column and the pump discharge head not exposed to view shall be coated both internally and externally with a modified epoxy, 6-8 mils dry thickness, or with the pump manufacturer's standard coating(s). The coating(s) shall be compatible with the intended pump service. Surface preparation shall be in accordance with the coating manufacturer's recommendations.
9. Discharge Gauge
  - a. The pump manufacturer shall furnish a discharge gauge for mounting on the centerline of the pump discharge.
  - b. The gauge shall accurately measure the pump discharge pressure.
  - c. The gauge shall be weatherproof, shall be calibrated, shall have a minimum 3-inch dial face, shall have an adjustable dial for field setting and calibration, and shall be the manufacturer's choice and/or standard gauge.
10. Fasteners: All pump and column fasteners and accessories shall be 316 stainless steel.
11. Manufacturer: In order to assure system compatibility and interchangeability with existing pumps, the pump shall be a duplicate of existing pump, NO SUBSTITUTIONS!!

### **PART 3 EXECUTION**

#### **3.01 FACTORY TESTING**

- A. Prior to shipment, each pump manufacturer shall perform certified factory tests on his respective pump in accordance with the requirements of Item 1.05 above.
- B. During the testing, the major pump parameters shall be recorded and the certified test results shall be forwarded to the Owner for review and approval prior to shipment of the pumps.

#### **3.02 PUMP HANDLING**

- A. After the pumps have been tested, all entrapped water shall be drained and proper care shall be taken to prevent the entrance of water during handling, packaging, and shipping.
- B. Finished iron or steel pump surfaces which are not painted shall be properly coated/protected to prevent rust and/or corrosion.
- C. Finished surfaces of all exposed pump openings shall be protected by strongly built wooden blanks securely bolted thereto.
- D. Factory assembled parts and components shall not be dismantled for shipment unless such dismantling is expressly approved, in writing, by the Owner.

#### **3.03 SHIPPING**

- A. The pumps shall each be so packaged for shipment that they are maximally protected from both physical and environmental damage.
- B. The pumps shall each be transported to the Owner's job site utilizing the respective manufacturer's customary method of shipment.

#### **3.04 INSTALLATION**

- A. The pumps shall be installed by the Owner's personnel in accordance with the recommendations and procedures set forth in the installation manuals furnished by each pump's respective manufacturer.
- B. An authorized factory trained representative(s) of each pump's respective manufacturer shall be available to assist the Owner's personnel on an "as needed" basis.

**3.05 WARRANTY**

- A. Each pump manufacturer shall furnish to the Owner a written warranty which complies with the requirements of Item 1.08 above.

**END OF SECTION**

## SECTION 11225 STATIC MIXERS

### PART 1 GENERAL

#### 1.01 SCOPE OF WORK

- A. Design, fabricate, and furnish, ready for installation by Owner's personnel, static mixing devices of the type, size, and capacity hereinafter specified and/or shown/described on the Contract Drawings.
- B. The mixing devices shall be furnished complete with all mounting hardware, auxiliary equipment, ancillary devices, installation instructions, and factory authorized supervisory personnel to allow Owner's personnel to satisfactorily complete the installation within the time constraints hereinafter specified. Any specialized tools, devices, or equipment required to install the mixing devices shall be furnished as a part hereof.

#### 1.02 LOCATION

- A. The mixing devices shall be installed in, and supported from the walls of the blending chamber at the Manatee County Water Treatment Plant.

#### 1.03 DESIGN CONSTRAINTS

##### A. Time

- 1. Since there is a maximum time frame of ten (10) hours during which the blending chamber can be taken out of service, and since some time must be allowed for unforeseen contingencies, the design of the mixing devices shall be such that they can be installed by the Owner's personnel under the supervision of the Manufacturer's authorized representative in one (1) continuous eight (8) hour period. Multiple periods of shutdown for mixing device installation will not be acceptable under these Specifications.

##### B. Size

- 1. The design of the mixing devices shall be such that all individual pieces or components, including the largest, must fit through a rectangular opening, measuring 29-inches by 90-inches.
- 2. The mixing devices shall be designed to fit into a channel of the blending chamber. The channel dimensions are 132-inches in width by 125-inches in height by 102-inches in length.

##### C. Material

- 1. Because of the corrosive nature of the chemicals being added to the water, the mixing devices, the device fasteners and mounting hardware, and ancillary devices shall be fabricated from 316L stainless steel.

#### 1.04 ANCILLARY DEVICES

##### A. Sparger

- 1. As part of the mixer installation, the Manufacturer shall design, fabricate, and furnish a sparger for adding chlorine to the water upstream of the mixers.

2. The sparger shall be fabricated from 4-inch diameter, Scheduled 40, 316L stainless steel pipe.

#### **1.05 FLOW RANGE**

- A. The mixing devices shall be designed to provide complete mixing of the chlorine between the flow range of 30 - 96 MGD.

#### **1.06 MIXING EFFICIENCY**

- A. The effectiveness of mixing shall be measured as follows:
  1. A minimum of six (6) blend chamber effluent samples designated field series) shall be collected over a one (1) hour period. The number of one (1) hour sampling periods during the twenty-four (24) hour acceptance test shall be determined by the Owner.
  2. Each sample shall be split and the split samples designated laboratory duplicates.
  3. All samples shall be analyzed for total phosphate, uncombined ammonia, and total combined chlorine.
  4. The mixing shall be considered effective if the standard deviation of the field series for each parameter is comparable to the mean standard deviation of the standard deviations calculated for the laboratory duplicate samples.

#### **1.07 FACTORY REPRESENTATIVE**

- A. An authorized factory representative of the Manufacturer of the mixing devices shall be on site during installation to supervise the Owner's personnel in the proper installation of the mixing devices and the sparger.
- B. After the mixing devices and the sparger are properly installed, the factory representative shall instruct the Owner's personnel in the proper care, adjustment, and disassembly of the devices.

#### **1.08 SUBMITTALS**

- A. The requirements of Section 01340 shall be met - i.e., the Manufacturer shall submit to the Owner for review and approval shop drawings, working drawings, and product data including all dimensions, details of fabrication, and materials used. All dimensions shall be based on field measurements made by the Manufacturer.
- B. The submittals shall include installation drawings which show all pertinent assembly details as well as certified calculations showing that the mixing devices meet the flow range and mixing accuracy as required by Items 1.05 and 1.06 above, respectively.

#### **1.09 FACTORY TESTING**

- A. After fabrication and prior to packaging and shipping, the mixers and the sparger shall be factory tested to ensure that they perform to the design specifications.
- B. Four (4) copies of the certified factory test results shall be shipped with the static mixers and the sparger.

#### **1.10 SHIPPING AND HANDLING**

- A. The Manufacturer shall so package the units for shipping that they are maximally protected from

both physical and environmental damage.

- B. The Manufacturer shall ship the units to the Water Treatment Plant using his normal means of transportation.
- C. The Owner shall store the units according to the Manufacturer's recommendations until the units are needed for assembly/installation.

#### 1.11 GUARANTEES AND WARRANTIES

- A. The Manufacturer shall guarantee and/or warrant, in writing, the mixing devices and the sparger against defects in materials, fabrication and workmanship as provided for in Section 01740 of these Specifications or for three (3) years from the date of final acceptance, whichever period is longer.

### PART 2 PRODUCTS

#### 2.01 TYPE

- A. The mixing devices shall be the static mixer type - i.e., they shall be rigidly mounted, shall contain no moving parts, and shall require no outside power source other than water flow to accomplish the required mixing action.
- B. The static mixers shall be a non-clogging design and shall be such that no surface edge or pinch-point shall be perpendicular to the direction of flow.

#### 2.02 CONSTRUCTION

- A. The static mixing system shall consist of a series of identical individual mixers combined with a chlorine sparger installed upstream of the first mixer. The Manufacturer shall be responsible for determining the minimum number of mixers required to achieve the required degree of mixing.
- B. Each mixer shall be a multi-blade design utilizing geometrically offset tapering blades to achieve the required degree of mixing. The Manufacturer shall be responsible for determining both the number of blades required and the actual blade geometry.
- C. The mixers and the sparger shall be fabricated from the materials specified in Items 1.03.C and 1.04.B above, respectively.

#### 2.03 MANUFACTURER

- A. The static mixers shall be the Type SMF as manufactured by the Koch Engineering Company of Fairfield, NJ, or approved equal product.

### PART 3 EXECUTION

#### 3.01 INSTALLATION

- A. The static mixers and the sparger shall be installed in the locations shown on the Contract Drawings. The installations shall be in strict accordance with the written instructions supplied by the Manufacturer.

#### 3.02 LABOR AND SUPERVISION

- A. The installations shall be performed by the Owner's personnel under the supervision of the Manufacturer's authorized representative.

**3.03 ALIGNMENT**

- A. All vertical surfaces and lines shall be installed plumb.
- B. All horizontal surfaces and lines shall be installed level.

**3.04 CLEAN UP**

- A. After the mixing system has been installed and prior to filling the blending chamber, the work area shall be thoroughly cleaned and all foreign items (scrap, slag, etc.) removed by the Owner's personnel.

**3.05 ACCEPTANCE TESTING**

- A. After the clean-up has been accomplished, the Manufacturer's authorized representative shall inspect both the static mixer and the sparger for proper installation. Additionally, to the extent possible, he shall check the sparger for proper operation.
- B. After both a satisfactory inspection and satisfactory sparger operation have been obtained, the blending chamber shall be refilled and a fully operational twenty-four (24) hour acceptance test shall be performed as specified above in Item 1.06, Mixing Efficiency.

**3.06 GUARANTEES AND WARRANTIES**

- A. The manufacturer shall guarantee and/or warrant, in writing, the static mixing system as required by Item 1.11 above and Section 01740 of these Specifications.

**END OF SECTION**



## SECTION 13350 LIFT STATION REHABILITATION

### PART 1 GENERAL

The Contractor shall furnish all labor, materials, equipment and incidentals required to remove / replace and install the internal equipment for a complete automatic, underground lift station and adjacent concrete valve and meter vault. The principal items of equipment shall include two submersible motor-driven sewage pumps (supplied and installed by Manatee County), valves, internal piping, pressure gauge, and meters (if required). All materials shall be new, without defects and of the best quality. All materials furnished and all work done shall be in strict accordance with all local requirements and codes.

### 1.01 EQUIPMENT

- A. Valve / Meter Vault: Precast concrete vault(s) shall be constructed as shown on the drawings and in accordance with section 03410. The vault(s) shall have a two (2) inch PVC drain with a P-trap return to the wetwell. The valve vault shall be adequate size to allow a minimum 12" clearance between all flange fittings and any concrete surfaces.
- C. Entrance Hatches: The lift station wetwell and vault(s) shall be equipped with an aluminum access cover sized as shown on the drawings. The wetwell access cover and valve pit access cover shall be constructed of aluminum with a minimum load rating of 300 lbs./sq. ft. and equipped with stainless steel hinges, hasp, and a device to lock the doors in an open position when the lid is raised (Bilco or approved equal).
- D. Sewage Pumps and Electrical (By MC)
- E. Piping and Fittings

Lift Station wetwell shall be as called out on the plans; types allowable are listed below. All flanged fittings in the wetwell and vault shall be connected using stainless steel hardware (nuts, bolts and washers). All mechanical joint fittings shall use grip rings restraint systems with Corten bolts.

1. PVC: C900, class 200, DR-14 or Schedule 80 with push-joint 90's.
2. HDPE: DR11 with shop fused butt joints and flanges.
3. Stainless Steel, either welded or grooved joint, per the plans.

#### E. Pump Hardware

1. Lifting chains shall be 3/8" stainless steel type 316 attached to the pump lifting bail using stainless steel shackles. All pump mounting systems shall be of the front loading slide rail type BPIU, from Barney's Pump). All rails and mounting hardware shall be stainless steel.
2. A stainless steel hanger shall be installed in each wetwell for supporting floatball and pump cables. The hanger shall be constructed of 1/4" x 2" type 316 stainless steel flat stock with individual hooks for each floatball and pump cable constructed of 1/4" type 316 stainless steel rod stock. All fasteners, brackets, and other hardware installed in the wetwell and valve vault shall be type 316 stainless steel.
3. Pump base plate for HDPE piping installations shall be as detailed in the Manatee County Utility Standards, latest edition, or as shown on the plans.

#### F. Painting

All paint and other coatings shall be applied in accordance with the project manufacturer's specifications for the surfaces being coated. The exterior of the valve pit and wetwell top below grade shall be coated with at least two (2) coats of a coal tar epoxy coating containing 78% volume of solids. The minimum thickness of each coat when dry shall be 8 mils. The interior surfaces of the valve vault shall be coated with two coats of Tnemec Series 69 Hi-Build epoxy coating or equal. The exterior surfaces of the valve vault and wetwell top exposed above grade shall be coated with at least two (2) coats of H & C Silicone acrylic concrete stain, Patio Green, Manufactured by FLR Paints, Inc. The interior and exterior or all ductile iron fittings and valves shall be per sections 02615 or 02640 of these specifications.

## **2.01 ELECTRICAL**

- A. Service and Metering (by MC): Electric service and meter are existing.
- B. Conductors: Manatee County will pull new pump power cords, contractor to pull all other conductors. MC will connect leads and conductors at the control panel unless noted otherwise.
- C. Conduit (by MC) or as shown on the plans.
- D. Control Panel (by MC) or as shown on the plans
- E. Gate Valves: All gate valves shall be resilient seated non rising stem. All valves inside the valve vault shall be equipped with handwheel.
- F. Link Seals: All piping penetrations of the wetwell and valve vault shall be through a grouted-in PVC sleeve that is bonded to the liner, sealed to the pipe using Link Seal Model S seals or approved equal. Install with bolts facing the outside of the wet well.

## **3.01 PERMITS**

The Contractor shall be responsible for and shall pay for any permits and/or inspections required.

## **4.01 SHOP DRAWINGS AND INSPECTIONS**

Shop drawings shall be submitted for approval in accordance with these Specifications prior to construction. When calling for inspection, the contractor should have these approved drawings available for review by the inspectors prior to acceptance by MC for maintenance. All inspections shall be arranged by contacting the Project Manager.

## **5.01 LANDSCAPING**

The Contractor shall grade and fill the construction area to its original lines and grades and sod all disturbed or damaged grassed areas. Manatee County Public Works Dept. shall restore the landscaping and shrubs around the lift station.

**END OF SECTION**

## SECTION 14600 HOISTS AND CRANES

### PART 1 GENERAL

#### 1.10 SCOPE OF WORK

Furnish all labor, materials, equipment, electrical, painting, and all incidentals necessary to construct the underhung motorized crane bridge and hoist system complete and operational.

#### 1.02 QUALIFICATIONS

Hoist and crane bridge shall be of approved standard design where possible and shall be adequate to maintain the supported load in proper position under all operating conditions.

#### 1.03 SUBMITTALS

- A. Submit to the Engineer for approval, as provided in the Contract Documents, shop drawings of all items to be furnished under this Section.
- B. Submit to the Engineer, for approval, samples of all materials specified herein.

### PART 2 PRODUCTS

#### 2.01 GENERAL

- A. Hoist described herein shall be not less than 2-1/2 and not more than 3 ton capacity, dual speed with geared trolley and a minimum lifting distance of 25 feet.
- B. The hoist shall meet the requirements of ANSI B30.16 "Overhead Hoists".
- C. The hoist shall be a heavy duty hoist meeting H4 Service classification as defined in ANSI/ASME HST-1M "Performance Standard for Electric Chain Hoists". Two speed models shall be rated H4 heavy duty for fast speed and H3 standard duty for slow speed. Maximum lifting speeds shall be 17/6 FPM.
- D. The underhung motorized crane bridge and electric hoist shall be as manufactured by Lift Tech International, Inc., Harrington Hoists, Inc., Budgit, or equal. Any reference to a specific catalog number of a specific manufacturer is for the purpose of establishing a type and quality of product and shall not be considered as proprietary. Any item comparable in type, style, quality, design and performance will be considered for approval.

#### 2.02 HOISTS

- A. **FRAME** - shall be of lightweight heat treated aluminum and precision machined for accurate gear and bearing alignment.
- B. **BEARINGS** - shall be high quality anti-friction type of either needle or ball design and used throughout the hoist.
- C. **BRAKES** - Hoist shall have two (2) types of brakes: One DC electrical motor brake spring set electrically released and one self-adjusting Weston type mechanical load brake located in the gear case. Either brake shall have the capability of holding rated load in event of failure of

either brake system.

- D. **OVERLOAD DEVICE** - shall be provided to prevent lifting excessive overloads. This load limiting (clutch) device shall be preset at factory to disengage the hoist motor from the gearing in event of excessive overload condition. Overload device is to be located between the motor and load brake, so that the load brake will hold the load in event of overload device failure.
- E. **MOTORS** - shall be of high starting torque type designed specifically for hoist service with permanently lubricated ball bearings, rated for the service required. The motor enclosure is to be totally enclosed non-ventilated TENV. Motor is to have automatic reset temperature actuated switch (TAS) in motor windings to provide motor running over current protection. Lifting motor shall be 460 volt, 3-phase, 60 Hz.
- F. **GEARING** - shall be a combination of helical and spur, precision cut and heat treated to ensure quiet, efficient operation. Gears shall be totally enclosed and run in a bath of oil to provide maximum lubrication and avoid environmental contamination.
- G. **LOAD CHAIN** - Link load chain shall be accurately formed closely calibrated pocket wheel chain of high strength low alloy steel, case hardened for long wear heavy duty service. Load chain shall be zinc plated.
- H. **LIMIT SWITCHES** - automatic upper and lower limit switches shall prevent raising or lowering the load beyond a preset upper or lower limit will be furnished. The upper limit switch shall be block operated.
- I. **SUSPENSION AND LOAD HOOKS** - shall be of high strength forged steel and be capable of full 360 degree rotation. Load hook shall have bearing supported rotation. Each hook shall have spring loaded hook latches to prevent accidental slippage from mounting or lift points.
- J. **CONTROLS** - shall be centralized electrical system, easily accessible in one compartment. Control circuit voltage to the pushbutton station shall not exceed 120 volts.
- K. **PUSHBUTTON STATION** - shall be of molded contour grip type and supported from hoist by strain relief cable to avoid damage from pull on control wires. Dependent on accessories, pushbutton station furnished will accommodate all motions. The enclosure is to be NEMA 4X watertight.
- L. **TROLLEY** - The wheels shall be steel with contour treads and shall operate on either flat or tapered beam flanges. Movement of hand geared trolley shall be accomplished by pulling on an endless hand chain. Trolley wheel gears and pinions shall have machine cut gear teeth. Spacer washers shall be provided for trolley adjustment to various sizes.

## 2.03 UNDERHUNG MOTORIZED CRANE BRIDGE

- A. **MOTOR** - Shall be a 460 volt, 3-phase, single speed, 1/3 H.P.(minimum) squirrel cage motor. It shall be C-face mounted to the reducer. Maximum bridge speed shall be 55 FPM.
- B. **END TRUCKS** - Shall be rigid steel welded, reinforced at the wheel axles and girder connection. The wheels shall be solid forged steel and rotate on two sealed lifetime-lubricated ball bearings. The single flange wheels shall have compound tread for operation on American standard taper tread or flat flange beams. The spur reduction at the truck shall be a steel pinion meshing with the integral gear teeth on the driver wheels. Maximum wheel load to be determined in accordance with CMAA Specification No. 74.

- C. **CROSS SHAFT SUPPORT (IF RECOMMENDED BY MANUFACTURER)** - Shall have antifriction lifetime-lubricated bearings.
- D. **GEAR REDUCER** - Shall be right-angle, shaft mounted and include all hardware for mounting at either end of the bridge.
- E. **CONTROL PANEL** - Shall be 460 volt, 3-phase, 60 Hz. It shall include mainline contactor, 115 volt control circuit transformer with fused secondary terminal strip, bridge fusing and reversing contactor, in a NEMA 1 enclosure, and all brackets, hardware, etc. required for attachment to end truck. A fused disconnect switch with positive power disconnect and crane fusing shall be mounted near the crane control enclosure.
- F. **ELECTRIFICATION** - Electrical power supply, materials, accessories, etc. to the crane and hoist shall be as recommended by the manufacturer.

**PART 3 EXECUTION**

**3.01 INSTALLATION**

- A. Hoist and underhung motorized crane bridge shall be installed as per manufacturer's recommendations.
- B. Contractor shall be acquainted with product and recognized by manufacturer as qualified to install the product.
- C. Contractor shall adequately store material prior to installation in a weatherproof area.
- D. The manufacturer of the crane and hoist shall make a representative available for a day of conducting on-site instructions to County personnel on the operation and maintenance of the overhead crane system. This service shall be included in the lump sum bid price. No additional expense shall be made to the County.
- E. Contractor shall prepare, prime and paint the entire system per section 09900.

**END OF SECTION**

## SECTION 15094 PIPE HANGERS AND SUPPORTS

### PART 1 GENERAL

#### 1.01 SCOPE OF WORK

Furnish all labor, materials, equipment and incidentals and install pipe hangers, supports, concrete inserts and anchor bolts including all metallic hanging and supporting devices for supporting exposed piping.

#### 1.02 QUALIFICATIONS

- A. Hangers and supports shall be of approved standard design where possible and shall be adequate to maintain the supported load in proper position under all operating conditions. The minimum working factor of safety for pipe supports shall be five (5) times the ultimate tensile strength of the material.

Note: Lift Stations have their own pipe support hanger and support design and detail, shown in the Utility Standards if not shown on the plans.

- B. All pipe and appurtenances connected to equipment shall be supported in such a manner as to prevent any strain being imposed on the equipment. When manufacturers have indicated requirements that piping loads shall not be transmitted to their equipment, the Contractor shall submit a certification stating that such requirements have been complied with.

#### 1.03 SUBMITTALS

- A. Submit to the Engineer for approval, as provided in the Contract Documents, shop drawings of all items to be furnished under this Section.
- B. Submit to the Engineer, for approval, samples of all materials specified herein.
- C. All pipe hangers, supports, hanger rods, clamps, concrete inserts and wall brackets, etc., whether specified or not, shall be submitted (together with load calculations) to the Engineer for approval, if requested.

### PART 2 PRODUCTS

#### 2.01 GENERAL

- A. All pipe and tubing shall be supported as required to prevent significant stresses in the pipe or tubing material, valves, and fittings and to support and secure the pipe in the intended position and alignment. All supports shall be designed to adequately secure the pipe against excessive dislocation due to thermal expansion and contraction, internal flow forces, and all probable external forces such as equipment, pipe, and personnel contact. All pipe supports shall be approved prior to installation.
- B. All materials used in manufacturing hangers and supports shall be capable of meeting the respective ASTM Standard Specifications with regard to tests and physical and chemical properties, and be in accordance with MSS SP-58.
- C. Hangers and supports shall be spaced in accordance with ANSI B31.1.0 except that the maximum unsupported span shall not exceed 10 feet unless otherwise specified herein.

- D. Unless otherwise specified herein, pipe hangers and supports shall be as manufactured by Grinnell Co., Inc., Carpenter and Patterson, Inc., or equal. Any reference to a specific figure number of a specific manufacturer is for the purpose of establishing a type and quality of product and shall not be considered as proprietary. Any item comparable in type, style, quality, design and performance will be considered for approval.

## 2.02 PIPE HANGERS AND SUPPORTS FOR METAL PIPE

- A. Suspended single pipes shall be supported by hangers suspended by steel rods from galvanized concrete inserts, beam clamps, or ceiling mounting bolts.

The following sizes are minimum requirements and are subject to the Engineer's approval:

1. Hanger rods shall be rolled steel machine threaded with load ratings conforming to ASTM Specifications and the strength of the rod shall be based on root diameter. Hanger rods shall have the following minimum diameters:

<u>Pipe Size, Inches</u>	<u>Min. Rod Diameter, In.</u>
Less than 2-1/2	3/8
2-1/2 through 4	1/2
4	5/8
6	3/4
8-12	7/8
14-18	1
20-30	1-1/4
Above 30	See SPECIAL SUPPORTS Paragraph 2.04

2. Where applicable, structural attachments shall be beam clamps. Beam clamps, for rod sizes 1/2-inch through 3/4-inch shall be equal to Grinnell Fig. No. 229, and for rod sizes 7/8-inch through 1-1/4 inches shall be equal to Grinnell Fig. No. 228, or equal.
3. Concrete inserts for pipe hangers shall be continuous metal inserts designed to be used in ceilings, walls or floors, spot inserts for individual pipe hangers, or ceiling mounting bolts for individual pipe hangers and shall be as manufactured by Unistrut Corp., Wayne, Michigan; Carpenter and Patterson, Inc., Laconia, New Hampshire; Richmond or equal and shall be as follows:
- Continuous concrete inserts shall be used where applicable and/or as shown on the Drawings and shall be used for hanger rod sizes up to and including 3/4-inch diameter. Inserts to be used where supports are parallel to the main slab reinforcement shall be Series P3200 by Unistrut Corp., Fig. 1480 Type 2 by Carpenter and Patterson, Inc. or equal. Inserts to be used where supports are perpendicular to the main slab reinforcement shall be Series P3300 by Unistrut Corp., Fig. 1480 Type I by Carpenter and Patterson, Inc., or equal.
  - Spot concrete inserts shall be used where applicable and shall be used for hanger sizes up to and including 7/8-inch diameter. Inserts shall be Fig. 650 by Carpenter and Patterson, Inc. for hanger rod sizes 1/2-inch through and including 3/4-inch and Fig. 266 by Carpenter and Patterson, Inc., for 7/8-inch hanger rods.
  - Ceiling mounting bolts shall be used where applicable and be for hanger rod sizes 1-inch through and including 1-1/4 inches shall be Fig. 104M as manufactured by Carpenter and Patterson, Inc. or equal.
  - All pipe hangers shall be capable of vertical adjustment under load and after erection. Turnbuckles, as required and where applied, shall be equal to

Grinnell Fig. No. 230.

4. Wall or column supported pipes shall be supported by welded steel brackets equal to Grinnell Fig. 194, 195 and 199 as required, for pipe sizes up to and including 20-inch diameter. Additional wall bearing plates shall be provided where required.
  - a. Where the pipe is located above the bracket, the pipe shall be supported by an anchor chair and U-bolt assembly supported by the bracket for pipes 4-inches and larger or by a U-bolt for pipes smaller than 4-inches. Anchor chairs shall be equal to Carpenter & Patterson Fig. 127. U-bolts shall be equal to Grinnell Fig. 120 and 137.
  - b. Where the pipe is located below the bracket, the pipes shall be supported by pipe hangers suspended by steel rods from the bracket. Hangers and steel rods shall be as specified above.
  - c. Wall or column supported pipes 2-inches and smaller may be supported by hangers equal to Carpenter and Patterson Figures 74, 179 or 237 as required.
5. Floor supported pipes 3-inches and larger in diameter shall be supported by either cast-in-place concrete supports or adjustable pipe saddle supports as directed by the Engineer. In general, concrete supports shall be used when lateral displacement of the pipes is probable (unless lateral support is provided), and adjustable pipe saddle type supports shall be used where lateral displacement of the pipes is not probable.
  - a. Each concrete support shall conform to the details shown on the Drawings. Concrete shall be poured after the pipe is in place with temporary supports. Top edges and vertical corners of each concrete support shall have 1-inch bevels. Each pipe shall be secured on each concrete support by a wrought iron or steel anchor strap anchored to the concrete with cast-in-place bolts or with expansion bolts. Where directed by the Engineer, vertical reinforcement bars shall be grouted into drilled holes in the concrete floor to prevent overturning or lateral displacement of the concrete support. Unless otherwise approved by the Engineer, maximum support height shall be five (5) feet.
  - b. Concrete piers used to support base elbows and tees shall be similar to that specified above.  
Piers may be square or rectangular.
  - c. Each adjustable pipe saddle support shall be screwed or welded to the corresponding size 150 lb. companion flanges or slip-on welding flanges respectively. Supporting pipe shall be of Schedule 40 steel pipe construction. Each flange shall be secured to the concrete floor by a minimum of two (2) expansion bolts per flange. Adjustable saddle supports shall be equal to Grinnell Fig. No. 264. Where used under base fittings, a suitable flange shall be substituted for the saddle.
  - d. Floor supported pipes less than 3-inches shall be supported by fabricated steel supports.
6. Vertical piping shall be supported as follows:
  - a. Where pipes change from horizontal to vertical, the pipes shall be supported on the horizontal runs within two feet of the change in direction by pipe supports as previously specified herein.
  - b. For vertical runs exceeding 15 feet, pipes shall be supported by approved pipe collars, clamps, brackets, or wall rests at all points required to insure a rigid installation.
  - c. Where vertical piping passes through a steel floor sleeve, the pipe shall be supported by a friction type pipe clamp which is supported by the pipe sleeve. Pipe clamps shall be equal to Grinnell Fig. 262.
7. Anchor bolts shall be equal to Kwik-Bolt as manufactured by Hilti Fastening Systems, Tulsa, Oklahoma or Wej-it manufactured by Wej-it Expansion Products, Inc., Bloomfield, Colorado.



8. All rods, hangers, inserts, brackets, and components shall be furnished with galvanized finish.

## 2.03 PIPE HANGERS AND SUPPORTS FOR PLASTIC PIPE

- A. Single plastic pipes shall be supported by pipe supports as previously specified herein.
- B. Multiple, suspended, horizontal plastic pipe runs, where possible, and rubber hose shall be supported by ladder type cable trays such as the Electray Ladder by Husky-Burndy, the Globetray by the Metal Products Division of United States Gypsum, or equal. Ladder shall be of mild steel construction. Rung spacing shall be approximately 18 inches for plastic pipe and 12 inches for rubber hose. Tray width shall be approximately 6-inch for single runs of rubber hose and 12 inches for double runs of rubber hose. Ladder type cable trays shall be furnished complete with all hanger rods, rod couplings, concrete inserts, hanger clips, etc. required for a complete support system. Individual plastic pipes shall be secured to the rungs of the cable tray by strap clamps or fasteners equal to Globe Model M-CAC, Huskey-Burndy Model SCR or equal. Spacing between clamps shall not exceed 9 feet. The cable trays shall provide continuous support along the length of the pipe.
- C. Individual clamps, hangers, and supports in contact plastic pipe shall provide firm support, but not so firm as to prevent longitudinal movement due to thermal expansion and contraction.

## 2.04 SPECIAL SUPPORTS

- A. The pipes shall be supported by means of a supporting framework suitably anchored into the floor or curbing. The vertical piping shall be suitably secured to horizontal support members connected at each end to vertical support members and spaced as required to provide a rigid installation.
  1. The complete supporting system shall be as manufactured by the Unistrut Corporation, Globe-Strut as manufactured by the Metal Products Division of U.S. Gypsum, or equal.
  2. Vertical and horizontal supporting members shall be U-shaped channels similar to Unistrut Series P1000. Vertical piping shall be secured to the horizontal members by pipe clamps or pipe straps equal to Unistrut Series P1100M and Series P2558. All components shall be of mild steel.
  3. The assemblies shall be furnished complete with all nuts, bolts, and fittings required for a complete assembly.
  4. The design of each individual framing system shall be the responsibility of the Contractor. Shop drawings shall be submitted and shall show all details of the installation including dimensions and types of supports.
- B. Any required pipe supports for which the supports specified in the Section are not applicable, including pipe supports for above 30-inch pipe, shall be fabricated or constructed from standard aluminum shapes in accordance with Specifications, concrete and anchor hardware similar to items previous specified herein and shall meet the minimum requirements listed below and be submitted to the approval of the Engineer.
  1. Pipe support systems shall meet all requirements of this Section and all related Sections of this Specification.
  2. Complete design details of the entire pipe support systems shall be provided by the Contractor, for approval by the Engineer.
  3. The pipe support system shall not impose loads on the supporting structures, in

- excess of the loads for which the supporting structure is designed.
4. Hanger rods for above 30-inch pipe shall be a minimum of 1-1/2 inch diameter and shall not exceed the manufacturer's standard maximum recommended safe load.
- C. Pipe supports in lift stations shall be as shown in the Utility Standards details.

## **PART 3 EXECUTION**

### **3.01 INSTALLATION**

- A. All pipes, horizontal and vertical, shall be rigidly supported from the building structure by approved supports. Supports shall be provided at changes in direction and elsewhere as shown in the Drawings or specified herein. No piping shall be supported from other piping or from metal stairs, ladders, and walkways, unless it is so indicated on the Drawings, or specifically directed or authorized by the Engineer.
- B. All pipe supports shall be designed with liberal strength and stiffness to support the respective pipes under the maximum combination of peak loading conditions to include pipe weight, liquid weight, liquid movement, and pressure forces, thermal expansion and contraction, vibrations, and all probable externally applied forces. Prior to installation, all pipe supports shall be approved by the Engineer.
- C. Pipe supports shall be provided to minimize lateral forces through valves, both sides of split type couplings, and sleeve type couplings and to minimize all pipe forces to pump housings. Pump housings shall not be utilized to support connecting pipes.
- D. Pipe supports shall be provided as follows:
  1. Cast iron and ductile iron shall be supported at a maximum support spacing of 10 feet-0-inches with a minimum of one support per pipe section at the joints.
  2. Supports for multiple PVC pipes shall be continuous wherever possible. Individually supported PVC pipes shall be supported as recommended by the manufacturer except that support spacing shall not exceed five (5) feet.
  3. Support spacing for galvanized steel pipe and copper tubing shall not exceed five (5) feet.
  4. All vertical pipes shall be supported at each floor or at intervals of at least 15 feet by approved pipe collars, clamps, brackets, or wall rests and at all points necessary to insure rigid construction.
- E. Pipe supports shall not result in point loadings, but shall distribute pipe loads evenly along the pipe circumference.
- F. Effects of thermal expansion and contraction of the pipe shall be accounted for in pipe support selection and installation.
- G. Inserts for pipe hangers and supports shall be installed on forms before concrete is poured. Before setting these items, all drawings and figures shall be checked which have a direct bearing on the pipe locations. Responsibility for the proper location of pipe supports is included under this Section.
- H. Continuous metal inserts shall be embedded flush with the concrete surface.

### **3.02 PRIME COATING**

- A. Prior to prime coating, all pipe hangers and supports shall be thoroughly clean, dry, and free from all mill-scale, rust, grease, dirt, paint, and other foreign substances to the satisfaction of the Engineer.
- B. All submerged pipe supports shall be prime coated with TNEMEC 69-1211 Epoxy Primer or equal. All other pipe supports shall be prime coated with TNEMEC 66-1211, or equal.
- C. Finish coating shall be compatible with the prime coating used and shall be applied as specified in the Contract Documents.

**END OF SECTION**

## SECTION 15400 PLUMBING

### PART 1 GENERAL

#### 1.01 SCOPE OF WORK

Furnish all labor, materials, equipment and incidentals necessary for complete installation of a plumbing system complete and ready for use.

#### 1.02 GENERAL

- A. The general arrangement of the plumbing shall be as indicated on the Drawings. Detached drawings of proposed departures shall be submitted to the Engineer for approval prior to the start of work. The Contractor shall carefully examine the Drawings and shall be responsible for the proper fittings of materials and equipment in each building. All work shall comply with local code requirements.
- B. Plumbing fixtures, devices and pipe shall be installed in such a manner to prohibit a cross connection or interconnection between a potable water supply and a polluted supply. The plumbing installation shall further prohibit the backflow of sewage, polluted water, or waste into the water supply system. Potable water hose bibs shall include vacuum breaker installation.
- C. Required materials not covered by the detailed Specifications shall meet the requirements of the local Plumbing Code, other applicable State and Local Ordinances and Codes, and shall conform to accepted plumbing practice.
- D. Drainage connections shall be trapped except as noted. The service line to each item of equipment shall be equipped with a cutoff valve and union for isolation of the item for repair and maintenance. Interference with the operation of other equipment or fixtures during repair or maintenance work is prohibited. The Contractor shall coordinate all work called for in the Contract Documents including, but not limited to furnishing the equipment with the services under this Section of the Specifications.
- E. The Drawings show a general concept of the plumbing system, but are not intended to show all of the offsets, fittings and accessories that may be required. The Contractor shall carefully investigate the structural and finish conditions affecting all his work and shall arrange such work accordingly, furnishing such fittings, traps, valves and accessories as may be required to meet such conditions, at no additional cost to the Owner.
- F. The work shall be carefully laid out in advance and no excessive cutting of construction will be permitted. Damage to buildings, piping, wiring, or equipment as a result of cutting for installation shall be repaired by mechanics skilled in the trade involved, at no additional cost to the Owner.
- G. Pipe openings shall be closed with caps or plugs during installation. Fixtures and equipment shall be tightly covered and protected against dirt, water and chemical or mechanical injury. Upon completion of all work, the fixtures, materials and equipment shall be thoroughly cleaned, adjusted and operated.

#### 1.03 SUBMITTALS

- A. The Contractor shall submit to the Engineer for review and approval in accordance with the Contract Documents: complete shop drawings, working drawings, and product data for all materials and equipment furnished under this Section.

#### **1.04 CODES, ORDINANCES AND PERMITS**

- A. The Contractor shall comply with all of the laws, ordinances, and codes, rules and regulations of the local and state authorities having jurisdiction over any of the work specified herein. He shall apply and pay for all necessary permits.
- B. If any part of the Plans and Specifications conflict with the laws and codes, the Contractor shall call it to the Engineer's attention prior to the commencement of work.

#### **1.05 GUARANTEE**

- A. The Contractor shall warrant all labor and materials free from defects for a period of one (1) year from the date of acceptance and shall, upon notification during this period, promptly repair or replace any defective items of material or equipment at no additional cost.

#### **1.06 ACCESSIBILITY**

- A. The Contractor shall inform himself fully regarding the peculiarities and limitations of the space available for the installation of all material in this Contract.
- B. The Contractor shall install the equipment, such as valves, traps, clean-outs, etc., so that it is readily accessible. He shall provide access panels where required. The foregoing shall also apply in general to any part of the system which may be necessary to be reached from time to time for maintenance and operations of the system.

### **PART 2 PRODUCTS**

#### **2.01 MATERIALS**

- A. Unless otherwise specified, all materials shall conform to the South Florida Plumbing Code.
- B. The revision of the particular ASTM, SBC or AWWA standard in effect at the time of advertisement for bids shall be the minimum acceptable.
- C. Copper water pipe shall be Type L, hard drawn tubing and fittings shall be cast brass or wrought copper.
- D. A dielectric coupling shall be provided between ferrous and nonferrous materials.
- E. The Contractor shall furnish certified statements from the manufacturer that the material conforms to the requirements specified above.

#### **2.02 SOIL, WASTE, DRAIN AND VENT PIPING**

Underground soil, waste and drain pipe and fittings shall be coated hub-and-spigot cast iron or cast ductile iron pipe, with dual-tite or tyseal joints. Above-ground soil, waste, drain and vent

pipng shall be service weight, cast iron soil pipe with No-Hub fittings. Waste arms and condensate waste, from air conditioning equipment, may be DWV copper. Cast ductile iron and galvanized steel pipe rainwater drainage systems shall be provided where shown on the Drawings, and as provided under this Section.

#### **2.03 CLEANOUT PLUGS AND TEST TEES**

Cleanouts shall be the same sizes as the pipe except that cleanout plugs larger than four inches shall not be required. A cleanout installed in connection with cast iron hub-and-spigot pipe shall consist of a long-sweep 1/4 bend or one or two 1/8 bends extended to the place indicated on the drawings, or, if not indicated, to an easily accessible place. All cleanouts extended through all floors shall be provided with cast access boxes which shall be Josam Series #58730 with Nikaloy cover.

#### **2.04 FLASHING**

Vent pipes and roof drains shall be flashed and made watertight at the roof with not lighter than 4-pound sheet lead. Flashings shall be extended up the vent pipes a minimum of six inches to form counter-flashing or rain guards for pipe. Flashings in connection with cast iron pipe vents shall be turned down into the pipes or hubs. Flashing shields shall extend not less than eight inches from the vent pipes and roof drains in all directions.

#### **2.05 TRAPS**

Unless otherwise indicated, each fixture and piece of equipment requiring connections to the drainage system shall be equipped with a trap. Traps are specified to be supplied with the fixtures. Each trap shall be placed as near the fixture as possible, and no fixture shall be double-trapped. Traps installed on bell-and-spigot pipe shall be cast iron. Traps installed on threaded pipe shall be recess drainage pattern. All floor drains shall have deep seal traps and be provided with Josam #88250 trap seal primer valve, where a single is required. Where multiple primers are required, see Drawings for primers and detail or as approved, to preclude trap liquid seal evaporation.

#### **2.06 SHOWER PAN**

The floor of each individual shower shall be made watertight with a metal pan or other approved materials fabricated in place. The metal pan shall be constructed from either 6-pound sheet lead or 16-ounce copper. The sheet metal shall be cut to size and shape of the shower area, allowing six inches for turn-up.

The corners shall be folded, not cut, and the corner seam shall be soldered or burned. The upstrands shall be recessed so that the pan will receive any seepage through materials above. The pans shall be coated with two coats of asphalt. Both sides of the pan including upstands shall be coated with asphalt paint. The pan shall be installed and the trap flange shall be countersunk to assure drainage. The trap shall be plugged and the pan filled with water as a test before installing the cement and tile.

#### **2.07 DRAINS**

Provide floor drains (FD) as manufactured by Josam, Zurn or Wade. All drains shall have nickel-bronze tops. All floor drains shall be as scheduled on the Drawings. Provide flashing clamp devices on all drains.

## 2.08 WATER PIPE, FITTINGS AND CONNECTIONS

- A. All water piping shall be Copper Type "L" except where otherwise noted on the Drawings. Copper pipe where code allows to be under slabs shall be continuous without joints, and encased in plastic pipe sleeves, its total length to include the turn to above slab.
- B. The piping shall be extended to all fixtures, outlets, and equipment from the gate valve. Plugged or capped fittings shall be provided for draining low points of the piping system. Outlets shall be capped or plugged and left ready for future connections.
  - 1. Piping shall be installed as indicated on the Drawings. Pipe shall be cut accurately to measurements established at the building by the Contractor and shall be worked into place without springing or forcing. Care shall be taken not to weaken structural portions of the building. Aboveground piping shall be run parallel with the lines of the building unless otherwise shown or noted on the drawings. Branch pipes from service lines may be taken from top, bottom, or side of main using such crossover fittings as may be required by structural or installation conditions. Service pipes, valves, and fittings shall be kept a sufficient distance from other work and other services to permit not less than 1/2-inch between finished covering and other work and not less than 1/2-inch between finished covering on the different services. Changes in pipe sizes shall be made with reducing fittings. Use of long screws and bushing will not be permitted.
  - 2. All water piping shall be installed so as to allow complete drainage through hose bibs, or 1/2-inch globe valves.
  - 3. Allowance for expansion and contraction shall be made throughout the system. Horizontal runs over 50 feet long shall be anchored to the wall or to the supporting construction about midway on the run to force the expansion movement to divide equally, half at each end. Sufficient flexibility shall be provided on all branch runouts from mains to risers to provide for expansion and contraction of piping. Flexibility shall be provided by installing one or more turns in the line so that the piping will spring enough to allow for expansion without staining.
  - 4. Air chambers shall be provided on all hot and cold supplies near each faucet, control valve, or flush valve, except hose faucets. Chambers shall be self-draining when the system is drained. If not definitely shown on the Drawings, air chambers shall consist of an 18-inch length of pipe one diameter larger than the branch supply, capped. Provide a mechanical shock absorber equal to Zurn Z-200 at any quick-closing valve, and other places air chambers are not approved.
- C. Threaded pipe shall conform to the requirements of other applicable paragraphs and sections of these Specifications. Unions shall be provided where required for disconnection of exposed piping. Unions shall be accessible.

## 2.09 VALVES

- A. Valves shall be provided on all supplies to fixtures and equipment. Valves indicated in connection with runouts, risers, branches, and mains shall be in accordance with this Specification. No valve shall be installed on any line with its stem below the horizontal. All valves shall be gate valves unless otherwise specified or indicated. Valves three inches and smaller shall be all bronze construction. Larger valves shall have iron bodies with brass trim. All valves shall be designed for a minimum working pressure of 125 psig saturated steam. Valves for use with ferrous pipe shall have threaded ends through 2-inch size, and flanged ends for larger sizes. Valves shall be equal to the following figure

numbers as manufactured by the William Powell Company:

TYPE	3" & SMALLER	3" & 3-1/2"	VALVES FOR COPPER	
	SCREWED ENDS		FLANGED	PIPING SWEAT ENDS
Gate	2700		1793	Nibco #S112
Gate (NRS)	2707		1787	Nibco #S113(NRS)
Check	578		559	Nibco #S413

1. Nonrising stem valves shall be used only where space conditions prevent use of rising stem valves, or where installed underground in valve boxes.
2. Check valves subject to back pressure, pulsations or reversal of flow, shall have provisions for quick closing by means of springs, weight and lever, or as approved.
3. A complete list shall be submitted for written approval. All valves shall be products of the same manufacturer.
4. Valves shall be products of William Powell Co., Crane, or approved equal.

## 2.10 UNIONS

Unions on ferrous pipe three inches in diameter and smaller shall be 150 pounds malleable iron, zinc-coated. Unions on water piping 3-1/2 inches in diameter and larger shall be flanged pattern, 125-pound class, zinc-coated. Gaskets for flanged unions shall be of the best quality fiber, plastic, or leather. Unions shall not be concealed in walls, ceilings, or partitions.

## 2.11 HOSE BIBS

Hose bibs shall be brass, polished chromium plated, as manufactured by Chicago Faucet Company. Potable water bibs shall be No. 952, 3/4-inch or 1-inch with vacuum breaker as noted on the Drawings. Equal by N1BCO, Purtecor Sill Cocks Model 763VB with built-in backflow preventor.

## 2.12 RELIEF VALVE

Provide an approved temperature and pressure relief valve for the electric water heater. Relief valve shall be equipped with manual test lever. Pipe relief valve discharge to building exterior or as approved.

## 2.13 PIPE SLEEVES, HANGERS AND FIXTURE SUPPORT

A. Pipe sleeves, hangers and fixture support shall be furnished and set, and the Contractor shall be responsible for their proper and permanent location.

1. Pipe sleeves shall be installed for pipes passing through footings, floors, walls and roof decks constructed with concrete and other cast-in-place materials. Clearance between sleeves and pipe covering and/or pipes shall be approximately 1/2-inch. Construction shall not be cut except where approved by the Engineer. Where cutting of construction is permitted, the construction shall be repaired to match its original condition. Sleeves located in exterior walls, concrete roof slabs, and floors on and below grade shall be sealed to make the space between pipe and sleeve watertight. Sleeves shall not be installed in structural members except where indicated or where the Contractor has received prior approval of the Engineer.
  - a. Pipe sleeves shall be installed for pipes that will pass through exterior walls and floors. Sleeves that pass through the floor shall extend 1 to 2 inches above the floor. The



- space between sleeve and pipe and/or pipe covering shall be sealed with plastic bituminous cement.
- b. Where plumbing piping (6 inches and smaller) passes through finished floors and the pipe will be exposed, the sleeve shall be fabricated of 3/16-inch (minimum) 316 stainless steel, and the sleeve shall be cut off exactly 1-inch above finished floor unless otherwise noted on the Drawings.
2. Pipe Hangers, Inserts and Supports:
    - a. Unless otherwise noted or detailed on the Drawings, pipe hangers and supports shall be Ginnell, ITT or approved equal. Pipe hangers shall be Fig. 107, Fig. 115 or Fig. 138; wall hooks Fig. 168; and brackets Fig. 223. Concrete inserts shall be equal to Fig. 281 and shall be installed before the concrete is poured. Wherever possible, ceiling hangers shall be supported utilizing toggle bolts of an approved type or ceiling flanges Fig. 128 or 128R, or as detailed on the Drawings.
    - b. Horizontal Piping: Hangers and supports shall be installed as specified hereinafter, and at locations not more than three feet from the end of each runout. A hanger shall be installed not over one foot from each change in direction of piping. In lieu of separate hangers, the Contractor may submit for approval by the Engineer a detailed drawing of trapeze hangers. Rings shall have a diameter large enough to include pipe insulation and protective saddle. Hangers for copper piping shall be copper plated.
      - 1) Cast iron soil pipe shall be supported at not more than five foot intervals and supports shall be located near each hub, or joint.
      - 2) Threaded pipe shall be supported at eight foot intervals.
      - 3) Underground piping shall be laid on a firm bed for its entire length, except where support is otherwise provided.
  3. Fixtures and equipment shall be supported and fastened in a satisfactory manner. Where secured to solid masonry, fixtures and equipment shall be fastened with brass bolts or machine screws in lead or corrosion-resisting-metal, sleeve type anchorage units or with brass expansion bolts. Expansion bolts shall be 1/4-inch brass bolts with 20 threads to the inch and of sufficient length to extend at least three inches into solid masonry construction, and shall be fitted with loose tubing or sleeves or proper length to ring expansion sleeves into the solid concrete or brick wall. Where secured to cellular masonry construction, fixtures and equipment shall be fastened with 1/4-inch brass toggle bolts or through bolts. Exposed heads of bolts and nuts shall be hexagonal with rounded tops finished and chromium plated; exposed ends of bolts shall be concealed by chromium plated hexagonal nuts. Exposed nuts and heads of screws shall be provided with chromium plated brass washers.

## 2.14 IDENTIFICATION TAGS

Identification tags made of brass, indicating function of the valve, size, and working pressure shall be installed on all valves except valves installed on supplies to plumbing fixtures. Tags shall be two inches in diameter and marking stamped and wired to valve with 0.0808-inch diameter (No. 12 AWG) copper wire. The Contractor shall also provide charts and diagrams of approved size giving the number, location and function of each valve, and distinguishing all pipe lines. Upon completion of the work, the Contractor shall furnish record drawings to the Engineer.

## 2.15 FLOOR, WALL AND CEILING PLATES

Exposed insulated and uninsulated pipes through floors, finished walls, or finished ceilings shall be fitted with chromium plated or enameled cast iron or steel plates. Plates shall be large enough to completely close the hole around the pipes and shall be square, octagonal, or round, with the least dimension not less than 1-1/2 inches larger than the diameter of the pipe. Plates shall be secured in an approved manner.

## **2.16 PIPE INSULATION**

- A. The Contractor shall provide insulation for all water lines above floor, the domestic hot water system, heat recovery system air conditioning condensate drain piping and the horizontal waste arm serving electric water cooler(s).
1. Hot water pipe insulation shall be Johns-Manville J-M Micro-Lok fiberglass pipe insulation, Certianteed Corp., or approved equal, finished with standard four ounce canvas jacket. Installation shall be in accordance with manufacturer's published recommendations.
  2. Condensate and electric drinking fountain waste shall be insulated with Johns-Manville J-M Aerotube, Certainteed Corp., or approved equal.

## **2.17 STRAINERS**

Strainers shall be 125-pound cast iron body Y-pattern with removable brass screen basket as manufactured by Sarco Company, or approved equal.

## **2.18 PRESSURE GAUGES**

Pressure gauges shall be 4-1/2 inch dial size with bottom or rear connection, weatherproof, as manufactured by Marshalltown, equal to No. 23 or 44, and suitable for the specific service pressure, by Trerice, Series 600 or 615; Ashcroft, or equal. Provide brass shut-off cocks on the stem to each pressure gauge.

## **2.19 PAINTING**

Exterior surfaces of piping to be installed in or through concrete shall be given one coat of acid resisting paint having a bituminous base. Pipe hangers, supports, and other iron work concealed or in unfinished spaces shall be thoroughly cleaned and painted with one coat of black asphaltic varnish. Finish painting of exposed pipe, pipe covering, hangers, supports, and other work is specified in the Contract Documents.

## **2.20 TYPES OF FIXTURES AND FIXTURE TRIMMINGS**

Provide the fixtures noted on the Drawings complete with all necessary trim.

## **PART 3 EXECUTION**

### **3.01 INSTALLATION**

- A. Drainage and Vent Pipes: Horizontal soil and waste pipes shall have a grade of 1/8-inch per foot except where 1/4-inch per foot is noted on the Drawings. All main vertical soil and waste stacks shall be extended full size to the roofline and above as vents, except where otherwise specifically indicated. Where practicable, two or more vent pipes shall be connected and extended as one pipe through the roof. Vent pipes in roof spaces shall be run as close as possible to the underside of the roof without forming traps in pipes, using fittings as required. Vertical vent pipes may be connected into one main vent riser above vented fixtures. All vent and branch vent pipes shall be so graded and connected as to drip back to the vertical stack by gravity. Cast iron no-hub pipes inside buildings shall be extended six inches above the floor. Roof vents shall be offset to maintain a distance of ten (10) feet minimum from air conditioning outside air intake, or any ventilating opening.

- B. Fittings: Changes in pipe size on soil, waste, and drain lines shall be made with reducing fittings or recessed reducers. All changes in direction shall be made by the appropriate use of 45 degree wyes, long or short sweep 1/4 bends, 1/6, 1/8 or 1/16 bends, or by a combination of those of equivalent fittings. Single and double sanitary tees and 1/4 bends may be used in drainage lines only where the direction of flow is from horizontal to vertical.
- C. Union Connections: Slip joints will be permitted only in trap seals or on the inlet side of the traps.
- D. Joints:
  - 1. Joints in hub-and-spigot cast iron soil, waste and vent pipes, or between cast iron soil, waste, and vent pipes and threaded pipe or caulking ferrules, shall be firmly packed with tarred-twisted jute packing and caulked with lead at least one inch deep.
  - 2. Threaded pipe joints shall be made by use of an approved mechanical cutter and all joints shall be reamed. No more than three threads shall remain exposed after assembly.

### 3.02 TESTS

- A. Soil, waste, vent and water piping shall be tested by the Contractor and approved before acceptance. Underground soil and waste piping shall be tested before backfilling. Equipment required for test shall be furnished by the Contractor at no additional cost to the Owner.
- B. Drainage and venting system piping shall be tested with water or air before the fixtures are installed. After the plumbing fixtures have been set and their traps filled with water, the entire drainage and venting system shall be submitted to a final test with smoke or peppermint.
  - 1. Water test shall be applied to the drainage and venting system either in its entirety or in sections. If the entire system is tested, all openings in the pipes shall be tightly closed except the highest opening, and the system shall be filled with water to the point of overflow. If the system shall be tested in sections, each opening except the highest opening of the section under test shall be tightly plugged, and each section shall be filled with water and tested with at least a 10 foot head of water. In testing successive sections, at least the upper 10 feet of the next preceding section shall be tested so that each joint or pipe in the building except the uppermost 10 feet of the system has been submitted to a test of at least a 10 foot head of water. The water shall be kept in the system, or in the portion under test, for at least 15 minutes before the inspection starts; the system shall then be tight at all joints.
  - 2. If tests are made with air, a pressure of not less than five pounds per square inch shall be applied with a force pump and maintained at least 15 minutes without leakage. A mercury-column gauge shall be used in making the air test.
  - 3. When the smoke test is employed, the smoke shall be produced by a smoke machine, and a pressure equal to one inch water column shall be maintained for 15 minutes before inspection starts. When the peppermint test is preferred, two ounces of peppermint shall be introduced into each line or stack. Defects discovered shall be eliminated by resetting the fixtures and equipment with new gaskets.
- C. Water System: When the roughing-in is completed and before the fixtures are set, the entire hot and cold water piping system shall be tested at a hydrostatic pressure of not less than 100 pounds per square inch gauge, and proved tight at this pressure for not less than 30 minutes in order to permit inspection of all joints. Where a portion of the water piping system is to be concealed before completion, this portion shall be tested separately as described for the entire system.

- D. Defective Work: If inspection or test shows defects, such defective work or material shall be replaced and inspection and tests repeated. Repairs to piping shall be made with new material; no caulking or peening of screwed joints or holes will be acceptable.

### **3.03 WATER FOR TESTING**

- A. The Contractor shall provide steam and water necessary for testing the piping systems. The Contractor shall make all connections for testing and remove all debris resulting therefrom. The water shall be used in an efficient and economical manner.
- B. Provide all apparatus and all other supplies or materials which may be necessary for testing the systems and operating the apparatus during the period while tests of any kind are being made, or for carrying out the work of the Contract.

### **3.04 CLEANING**

- A. At the completion of the work, the Contractor shall clean and polish, ready for use, all fixtures, equipment, apparatus and exposed trim.
- B. The Contractor shall protect this work during construction and all finished work damaged during construction shall be replaced at no additional cost to the Owner.

### **3.05 PROTECTION**

- A. Materials, fixtures, and equipment shall be properly protected at all times and all pipe openings shall be temporarily closed so as to prevent obstruction and damage.

### **3.06 STERILIZATION**

The entire potable water collection and distribution system shall be thoroughly sterilized with a solution of not less than 50 parts per million of available chlorine. The sterilizing solution shall be allowed to remain in the system for a period of three hours after which time all valves and faucets shall be opened and the system shall be flushed with clean water until the residual chlorine content is not greater than 0.92 parts per million, unless otherwise directed.

**END OF SECTION**

## SECTION 15500 AIR CONDITIONING SYSTEM

### PART 1 GENERAL

#### 1.01 SCOPE

Furnish and install a complete air conditioning system for climate control of the Pump House. The system shall be a five (5) ton high efficient air conditioning unit manufactured by Carrier, York or approved equal, with a minimum SEER rating of 12. The system shall include all necessary components to insure a complete operable system. The major components shall include inside air handler/evaporator unit, outside condensing unit, duct system, condensate line, thermostat, electrical power and wiring.

#### 1.02 CODES AND STANDARDS

All work performed under this specification shall conform to the requirements of the latest edition of the following codes and standards as modified by local ordinances:

NFPA Compliance: Comply with applicable provisions of ANSI/NFPA 70 National Electric Code. Also conform to Pamphlet 90A of NFPA.

Flame-Smoke Ratings: Provide air handling unit thermal insulation with flame-spread index of 25 or less, fuel-contributed index of 50 or less, and smoke-developed index of 50 or less.

AMCA Standards: Comply with Air Movement and Control Association (AMCA) standards as applicable for testing and rating fans, and testing louvers, dampers and shutters.

SMACNA Compliance: Comply with Sheet Metal and Air-Conditioning Contractors National Association (SMACNA) duct work construction standards.

American Society of Heating, Refrigerating and Air-Conditioning Engineers, Inc. (ASHRAE) Handbook.

ARI Certification: Provide central station packaged air handling units which comply with Air-Conditioning and Refrigeration Institute (ARI) Standard 430 and display ARI certification symbols.

UL Compliance: Provide electric components for air handling units which have been listed and labeled by Underwriters Laboratories.

Construction shall comply with ANSI B9.1 safety code.

Standard Building Code.

Standard Mechanical Code.

National Warm Air Heating and Air Conditioning Association - Manual 4.

#### 1.03 PRODUCT DELIVERY, STORAGE AND HANDLING

- A. Deliver all components in factory-fabricated protective containers.
- B. Handle all components carefully to avoid damage to components, enclosures and finish. Do not install damaged components; replace and return damaged components to manufacturer.
- C. Store all components in clean dry place and protect from weather and construction traffic.

#### 1.04 SUBMITTALS

- A. Thoroughly coordinated shop drawings shall be submitted for approval.

- 1. Submit shop drawings and complete performance data for all major pieces of

equipment, showing dimensions arrangement, connection sizes, electrical wiring diagram, power requirements and clearances required for access of service. Shop drawings shall include factory certification that the equipment has the required capacity, or shall include copies of manufacturer=s published performance data.

2. Equipment proposed will require complete shop drawings, which clearly show how the equipment fits the available space and in relation to adjacent equipment, with all connections shown such as piping and duct work.
3. Provide submittal data for major component, air distribution devices, installation materials and duct work.
4. Submit for approval complete power and control field wiring diagrams.
5. Submit for approval a drawing indicating location and sizes of all wall penetrations and supports required for this work.

- B. All shop drawings submitted for approval shall be stamped by the Contractor before submission to indicate that the shop drawings are complete, checked and comply with all aspects of the requirements of all Contract Documents.
- C. Shop drawing approvals by the Engineer will not relieve the Contractor from responsibility for his own errors, nor from his responsibility for full compliance with the Contract Documents.
- D. All data and drawings shall be submitted simultaneously in an indexed booklet.
- E. Warranty for the equipment under this Section.

#### 1.05 OPERATING AND MAINTENANCE MANUALS

- A. When the installation is completed, submit to the Engineer, one copy of the following, bound in a hard cover booklet:
  1. General operating instructions, including copies of posted specific instructions and automatic control diagrams.
  2. Maintenance instructions, followed by tabulated manufacturer=s descriptive literature, shop drawings, performance curves and rating data, spare parts lists and manufacturer=s maintenance manuals.
  3. Names, addresses and telephone numbers of local service representatives of the manufacturer=s of the installed equipment.

### PART 2 PRODUCTS

#### 2.01 OUTSIDE CONDENSING UNIT

- A. Provide factory assembled self-contained, air cooled condensing unit, complete with compressor section, integral condenser, all necessary controls and interconnecting refrigerant piping. Furnish manufacturer=s five (5) year parts and labor warranty for motor compressor.
- B. All components shall be protected against corrosion and shall be mounted in a steel casing of a minimum of 14-gauge panels with steel angle framing and adequate access panels for inspection and maintenance.
- C. Provide all piping, valves, and fittings required to properly interconnect all system components.
- D. Tubing for coils shall be copper; fins shall be aluminum.

## 2.02 INSIDE AIR HANDLER/EVAPORATOR UNIT

- A. Casing walls shall be fabricated of continuous galvanized steel and coated with baked enamel finish not lighter than 18 gauge. Removable panels shall provide access to the interior of the unit.
- B. Fan and coil sections shall be internally insulated with 1-inch thick, 3 lb. density neoprene coated fiberglass. Insulation shall be secured to the casing with waterproof adhesive and permanent fasteners.
- C. Fan wheel shall be forward curved type, non-overloading, and keyed to the shaft. Fan wheel shall be dynamically and statically balanced at factory.
- D. V-belt driven fan shall be designed for 50 percent overload capacity.
- E. Bearings shall be designed for a minimum of 200,000 hours average life.
- F. Coil section shall encase cooling coils and drain pan. Coils shall be arranged for horizontal air flow. Coil headers, valves and all piping shall be completely enclosed within the insulated casing.
- G. Tubing for coils shall be copper. Fins shall be aluminum.
- H. Drain pan shall be galvanized steel, with a heavy coat of mastic.
- I. Filter Section: Filter section shall be designed to hold throwaway filters.

## 2.03 SHEET METAL DUCTWORK

- A. All round and rectangular sheet metal duct work shall be fabricated from galvanized sheet steel complying with ASTM A 527, Lock forming Quality; with G 90 zinc coating in accordance with ASTM 525. Zinc coating shall be of uniform thickness; free from blisters, slivers and pits; and capable of withstanding normal sheet metal forming operating without flaking or splitting.
- B. Joints, gauge, reinforcement and fabrication techniques shall conform to minimum standards listed in SMACNA ΔHVAC Duct Construction Standards@ using actual duct dimensions and system pressures.
- C. Ductwork shall be installed in strict accordance with manufacturer=s recommendations and in compliance with SMACNA ΔHVAC Duct Construction Standards@.
- D. Thermal Insulation:
  - 1. Insulation material shall be similar in all respects to that manufactured by Owens-Corning, Certainteed, Armstrong, or equal. Exterior wrap for sheet metal shall be type 703 FRK 25. Provide and install all thermal insulation for the HVAC system.
  - 2. Except for materials which are subsequently exempted, all other materials used as part of the thermal insulation shall have a fire hazard rating not to exceed 25 for flame spread and 50 for fuel contributed and smoke developed.
- E. Components:

1. Provide all adhesives, sealers, vapor barrier coatings, etc., compatible with the material to which they are applied. They shall not corrode, soften, or otherwise attack such material in either the wet or dry state and must be suitable for the service temperature.

F. Ceiling Diffusers:

Provide adjustable-blade high-performance louver with 6" frame depth, constructed of extruded aluminum.

G. Sound Adsorption and Isolation:

Neoprene vibration isolation supports shall be provided on the air conditioning unit and other equipment that may transmit noise or vibration to the building structure.

**2.04 TEMPERATURE CONTROLS**

Furnish and install a heavy duty corrosion resistant wall mounted thermostat with locking cover. Use Carrier thermostat control or equal.

**PART 3 TESTING AND BALANCING**

- A. The Contractor shall test and balance the air conditioning system.
- B. The term "air conditioning systems" shall be understood and intended to mean all air conditioning supply systems, and all associated equipment and accessories.

**PART 4 EXECUTION**

**4.01 GENERAL**

- A. Install the air conditioning system where indicated, in accordance with equipment manufacturer's written instructions, and with recognized industry practices, to ensure that units comply with requirements and serve intended purposes.
- B. Coordinate with other work, including plumbing, ceiling and truss construction, roof decking, electric, piping, and overhead crane system as necessary to interface installation of air handling units with other work.
- C. Install air handling unit on vibration mounts and comply with manufacturer's indicated installation method.
- D. Spare Parts:
  1. Provide one complete extra set of filters for the air handling unit. Install new filters at completion of air handling system work, and prior to testing, adjusting and balancing work.
  2. Provide one spare set of belts for the air handling unit.

**4.02 INSTALLATION**

- A. All major components shall be rigidly and strongly supported with suitable braces, tees, or angles to keep them true to shape and prevent buckling.



- B. Pocket joints or bar slips, if used, must be riveted at the corners. Approved means must be provided to prevent pocket and slip joints pulling apart such as riveting on 12 inch centers, clip punching on 8 inch centers or button pressing on 4 inch centers. Sheet metal screws puncturing ducts will not be allowed in the construction of seams and joints.
- C. Sealing and Leak Testing: All seams, joints, gaps, holes, etc. in the ductwork shall be sealed with mastic and checked for airtightness before insulation is applied.
- D. Ductwork Cleaning: Contractor shall thoroughly clean all ductwork chambers, fans, etc., manually. After this is done, blow out the systems with a built-up velocity so as to properly clean the interior of all ductwork, leaving same free of all foreign matter. The cleaning work shall be done before any painting is done.

**END OF SECTION**

## SECTION 16050 ELECTRICAL - GENERAL PROVISIONS

### PART 1 GENERAL

#### 1.01 SCOPE OF WORK

- A. Furnish all labor, materials, devices, equipment, appurtenances, and incidentals required for a complete electrical system as hereinafter specified and/or shown on the Contract Drawings. This work may necessarily include interfacing with and/or completely installing devices and/or equipment furnished under other sections of these Specifications.
- B. It is the intent of these Specifications that the electrical system be suitable in every way for the service required. All materials and all work/labor which may be reasonably implied as being incidental to the requirements of this Section shall be furnished at no additional cost to the Owner.
- C. All power interruptions to existing equipment shall be at the Owner's convenience. Each interruption shall have prior approval. Request(s) for power interruption(s) shall be made at least forty-eight (48) hours in advance.
- D. The work shall include complete testing of all electrical components, including wiring.
- E. All workmanship shall be of the highest quality. Substandard work will be rejected and it shall be replaced entirely at the Contractor's expense with no cost to the Owner.
- F. It shall be the responsibility of each bidder or his authorized representative to physically visit the job site in order that he may be personally acquainted with the area(s), buildings and/or structures intended for use in the installation/construction under this Specification. The submittal of a proposal/bid by a bidder shall be considered evidence that he has complied with this requirement and accepts all responsibility for a complete knowledge of all factors governing his work. Therefore, failure to comply with this requirement of the Specifications will NOT be grounds for the successful bidder (Contractor) to request approval of change orders and/or additional monetary compensation.

#### 1.02 TEMPORARY ELECTRICAL SERVICE

- A. The Contractor shall make the requisite arrangements for securing temporary electrical power for his use in accordance with Section 01510 of these Specifications.

#### 1.03 CODES, INSPECTIONS AND FEES

- A. All materials and installations shall be in accordance with the National Electrical Code (latest edition) and the latest editions of all applicable national, state, county and local codes.
- B. To the extent that any item is routinely tested and rated by the Underwriter's Laboratories, Inc., that item shall bear the U.L. label. Additionally, all items shall be manufactured to the applicable NEMA standards.
- C. The Contractor shall make the necessary arrangements for obtaining all requisite permits and inspections and pay any applicable fees.

#### 1.04 TESTS

- A. The Contractor shall test all items individually and as a system for proper operation.
- B. The Contractor shall, at his expense, make all the requisite repairs, adjustments and/or alterations to correct any shortcomings found as a result of the tests performed under Item 1.04.A above.
- C. A representative of the Owner shall be present during all testing. The Owner shall be notified at least two (2) days prior to any testing.

#### 1.05 SLEEVES AND FORMS FOR OPENINGS

- A. Provide and place all sleeves for conduits penetrating floors, walls, partitions, etc. Locate all necessary slots for electrical work and form before concrete is poured.

#### 1.06 CUTTING AND PATCHING

- A. All cutting and patching shall be done in a thoroughly workmanlike manner - i.e., care shall be taken when cutting not to damage or mar surrounding areas, and when patching to match the original finish as closely as possible while providing a watertight seal. Refer to Item 1.01.E above.

#### 1.07 INTERPRETATION OF DRAWINGS

- A. The layouts and arrangements as shown on the Contract Drawings are indicative of the physical arrangements desired; however, they are not intended to restrict the Contractor's freedom to accommodate the exact conditions as found in the field. Any deviations from the arrangements shown must be approved by the Owner prior to the final placement of the item(s) in question.
- B. The Contract Drawings are not intended to show exact locations of conduit runs.
- C. Circuit and conduit layouts shown are not intended to indicate the exact installation details. The Contractor shall furnish and install all requisite items, including all fittings, junction boxes, etc., to insure that the electrical system operates in conformance with the Specifications and the specific requirements of an individual piece of equipment.
- D. Where circuits are shown as "home-runs", all necessary fittings and boxes shall be provided for a complete conduit installation.
- E. All three-phase circuits shall be run in separate conduits unless otherwise shown on the Contract Drawings.
- F. Surface mounted items such as panelboards, junction boxes, conduit, etc., shall be supported by spacers to provide a clearance between the equipment and the mounting surface.
- G. The Owner shall make the final decision in determining the exact location(s) and mounting height(s) of any item(s) or piece(s) of equipment in question.
- H. All connections to equipment shall be made in accordance with the approved shop and manufacturer's drawings, regardless of the number of conductors shown on the Contract Bid Drawings.
- I. The Contractor shall coordinate the work of the different trades in order to prevent

interferences between conduit(s), piping and other non-electrical equipment. In case any interference develops, an authorized representative of the Owner shall decide which equipment, conduit(s) or piping must be relocated, regardless of which was installed first. Any such interferences shall be remedied solely at the Contractor's expense without any additional cost to the Owner.

#### 1.08 EQUIPMENT SIZING AND HANDLING

- A. The Contractor shall thoroughly check all entryways, doors, hallways, stairways, buildings and structures through which equipment must be transported to reach its final location.
- B. If necessary for safe passage of the equipment, the manufacturer shall be required to ship his material in sections sized to pass through the restricted areas. This requirement holds even if such equipment sizing differs from the manufacturer's standard shipping section.
- C. To the extent possible, the equipment shall be kept upright at all times. If equipment has to be tilted for ease of passage through restricted areas, the manufacturer shall provide specific handling instructions as well as any requisite bracing in order to assure both the functional integrity of the equipment and the validity of the equipment warranty.

#### 1.09 SUBMITTALS

- A. As specified under Section 01340 of these Specifications, the Contractor shall submit shop drawings and/or manufacturer's cut sheets for approval of all materials, equipment, devices, apparatus, and other items as required by the Owner.
  - 1. Prior to submittal by the Contractor, all shop drawings shall be checked for accuracy and Contract requirements. Shop drawings shall bear the date checked and shall be accompanied by a statement that the shop drawings have been examined for conformity to the Specifications and Contract Drawings. This statement shall also list all discrepancies with the Specifications and Contract Drawings. Shop drawings not so checked and noted shall be returned unchecked by the Owner.
  - 2. The Owner's check shall be only for conformance with the design concept of the Project and compliance with the Specifications and Contract Drawings. The responsibility for, or the necessity of, furnishing materials and workmanship required by the Specifications and Contract Drawings which may not be indicated on the shop drawings is included under the work of this Section.
  - 3. No material shall be ordered, no equipment manufacturing shall be started, nor shall any shop work/fabrication commence until the Owner has approved the shop drawings. Any deviation from this requirement of the Specifications shall be entirely at the risk and expense of the Contractor without any additional cost to the Owner.
- B. Record Drawings: As the work progresses, the Contractor shall legibly record all field changes on a set of Contract Drawings. When the project is completed, the Contractor shall furnish the Owner with a complete set of reproducible "as-built" drawings.

#### 1.10 MANUFACTURER'S SERVICES

- A. The Contractor shall arrange for an authorized manufacturer's representative who shall be an experienced field service engineer to be present for the inspection, installation, testing, calibration, adjusting and start-up of any item(s) or piece(s) of equipment as deemed

necessary by the Owner.

- B. In addition to the duties of Item 1.11.A above, the manufacturer's representative shall also instruct the Owner's personnel in the proper operation and maintenance of the item(s) in question.

#### 1.11 MATERIALS

- A. All materials used shall be new, unused and as hereinafter specified. Where not specifically called out, all materials shall be of the very best quality of their respective kinds. Unless specifically otherwise approved in writing by the Owner, only material manufactured in the United States shall be used!
- B. Where applicable, all materials and equipment shall conform with the requirements of Item 1.03.B above.
- C. Electrical equipment shall at all times during construction be adequately protected against both mechanical injury and damage by water. Electrical equipment shall be stored indoors in dry shelters. Any damaged equipment shall be replaced by the Contractor at his own expense.
- D. All items shall be manufactured from the materials specified - substitute materials will NOT be acceptable.
- E. Only the specified manufacturer's equipment shall be used unless an "or approved equal" is noted. The Owner shall be the sole determiner of what constitutes an "approved equal".

#### 1.12 GUARANTEES AND WARRANTIES

- A. All items furnished under the Electrical Specifications shall be guaranteed and/or warranted, in writing, against defects in materials, construction and workmanship as specified under Section 01740 of these Specifications.

END OF SECTION

## SECTION 16108 MISCELLANEOUS EQUIPMENT

### PART 1 GENERAL

#### 1.01 SCOPE OF WORK

- A. Furnish and install all miscellaneous equipment as hereinafter specified and/or shown on the Drawings.
- B. Installation shall be in the locations described herein and/or shown on the Drawings and/or where directed by the Owner's authorized personnel.

### PART 2 PRODUCTS

#### 2.01 MATERIALS

##### A. CIRCUIT BREAKERS

- 1. The circuit breakers shall be the molded case bolt-on type, shall have a single pole, shall be rated 20-amperes at 120/240 VAC, and shall have an interrupting rating of 10,000-amperes.
- 2. To match existing equipment, the circuit breakers shall be the Square "D" Catalog No. Q0B120 with "VISI-TRIP" indicator for use on a Square "D" NQOD panelboard, NO SUBSTITUTIONS!

##### B. SAFETY SWITCHES

- 1. The safety switches shall be the visible blade, non-fusible, heavy duty type, shall have a quick-make, quick-break, single throw operating mechanism, and shall have both a dual cover interlock and a color coded indicator handle.
- 2. The safety switches shall have three (3) poles, shall be rated 30-amperes at 600 VAC, shall have all current carrying parts made of copper, and shall be furnished in a NEMA 3R rainproof enclosure.
- 3. The safety switches shall have 1-inch bolt-on hubs, a solid neutral assembly, and a copper ground kit.
- 4. In addition to being UL listed under files E2875 and 154828, the safety switches shall comply with the following standards:
  - a. UL 98, Enclosed and Dead Front Switches.
  - b. NEMA KS1, Enclosed Switches.
  - c. Federal Spec WS-865c for Type "HD".
- 5. To match existing equipment, the safety switches shall be the Class 3110 Heavy Duty Safety Switch, Square "D" Catalog No. HU361RB, NO SUBSTITUTIONS!

##### C. FLOW METER

- 1. Two (2) flow meters shall be provided. One (1) flow meter shall be installed as hereinafter described and one (1) flow meter shall be shelf-stored in the original factory packing.
- 2. The flow meters shall be the Doppler type with separately mounted electronics and two (2) non-intrusive strap-on transducer assemblies.
- 3. The installed transducers shall be attached to the outer periphery of the pipe with stainless steel straps which shall be furnished as part of the flow meter package.

Additionally, the transducers shall be furnished with a 30-foot long cable to interconnect with the meter electronics.

4. Both flow meter electronics shall have the following:
  - a. Accuracy to plus or minus 2% of the actual flow.
  - b. User-friendly keypad programming.
  - c. 90,000 point data logger.
  - d. Flow range of 0.05 to 32.0 feet per second.
  - e. Both 4-20 maDC and RS 232 outputs.
  - f. Supply voltage of 90-132 VAC, 60 Hertz, single phase.
  - g. Four (4) relays with 5 Amp SPDT contacts, fully programmable.
5. To match existing equipment, the flow meter shall be Catalog No. SX4041-100A as manufactured by Polysonics, **NO SUBSTITUTIONS!**
6. The electronics of the installed flow meter shall have a PVC or fiberglass weatherproof enclosure with a hinged cover (left vertical side) and clamps or clasps along the other three sides. The enclosure shall be approximately 24-inches square by 10-inches deep. The enclosure shall have an aluminum mounting backplate and shall be furnished with an interior-mounted duplex receptacle (see Item D.1 below). The flow meter enclosure shall be as manufactured by Hoffman, Rob Roy, or approved equal.

#### D. DUPLEX RECEPTACLES

1. Flow Meter Enclosure
  - a. The duplex receptacle shall be the ground fault circuit interrupter (GFCI) type, shall be rated 20-amperes at 125 VAC and shall be of the NEMA 5-20R configuration.
  - b. The duplex receptacle shall be made of brown nylon and shall be back and side wireable.
  - c. The duplex receptacle shall be Hubbel Catalog No. 5362, or approved equal.
  - d. The duplex receptacle shall be furnished with a surface mounted PVC or plastic device box.
  - e. The duplex receptacle shall be furnished with a brown nylon cover plate (both cover plate and duplex receptacle must be from the same manufacturer). The cover plate shall be Hubbel Catalog No. P8X, or approved equal.
2. New Meter Vault
  - a. The duplex receptacle shall be the ground fault circuit interrupter (GFCI) type, shall be rated 20-amperes at 125 VAC and shall be of the NEMA 5-20R configuration.
  - b. The duplex GFCI receptacle shall have a brown nylon face, shall have pre-stripped 4-inch back wire leads, and shall have captive mounting screws.
  - c. The duplex GFCI receptacle shall have a band on reset button to provide a visible indication of a ground fault trip.
  - d. The duplex GFCI receptacle shall be Hubbell Catalog No. GF5362, or approved equal.
  - e. The duplex GFCI receptacle shall be furnished with a surface mounted PVC or plastic device box.
  - f. The duplex GFCI receptacle shall be furnished with a zinc die cast weatherproof cover plate with dual flip lids (both cover plate and duplex GFCI receptacle must be from the same manufacturer). The cover plate shall be Hubbell Catalog No. CWP8H, or approved equal.

#### E. PAD SUPPORT STRUCTURE

1. A support structure, firmly embedded into the concrete pad outside the East wall of the new meter vault, shall be provided onto which the two (2) safety switches and the flow meter electronics enclosure shall be mounted.
2. The support structure shall be fabricated from stainless channels and shall have all stainless steel mounting hardware.
3. The height of the support structure shall be such as to maintain an even 6'-0" mounting height from the top surface of the concrete pad to the top surface of the individual devices mounted on the support structure.
4. The width of the support structure as well as the length and width of the steel reinforced concrete pad are predicated on the use of the devices specified elsewhere in this Section. If other than the specified items are used, the respective dimensions may have to be altered accordingly.
5. The stainless steel channel and stainless mounting hardware shall be as manufactured by Unistrut, Kindorf, or approved equal.

**PART 3**      **EXECUTION**  
**(NOT USED)**

**END OF SECTION**



## SECTION 16110 CONDUITS AND FITTINGS

### PART 1 GENERAL

#### 1.01 SCOPE OF WORK

Furnish and install the conduits, fittings, devices and appurtenances as hereinafter specified and/or as shown on the Contract Drawings.

#### 1.02 SUBMITTALS

The requirements of Section 01340 and Section 16050 shall be met.

#### 1.03 APPLICATIONS

- A. Except where otherwise shown on the Contract Drawings, or hereinafter specified, all wiring shall be run in rigid conduits.
- B. Galvanized rigid steel conduits shall be used at all locations aboveground and within structures and buildings except where otherwise shown on the Contract Drawings.
- C. Galvanized rigid steel conduits shall be used at all locations for shielded instrumentation and shielded control wiring except where otherwise shown on the Contract Drawings.
- D. Schedule 80 PVC conduits shall be used for all underground, under-slab and in-slab applications except where otherwise shown on the Contract Drawings.
- E. Schedule 80 PVC conduits shall be used in highly corrosive areas such as chlorine storage areas, digesters, fluoride storage and handling areas, etc.
- F. All conduits of a given type shall be the product of one manufacturer.
- G. Except where otherwise shown on the Contract Drawings, or hereinafter specified, all boxes shall be metal.
- H. Flush mounted switch, receptacle and control station boxes shall be pressed steel.
- I. Surface mounted switch, receptacle and control station boxes shall be cast or malleable iron.
- J. Devices designated as NEMA Type 4 shall be 316 stainless steel, gasketed.
- K. Devices designated as NEMA Type 4X shall be fiberglass, gasketed, except as otherwise shown on the Contract Documents.
- L. Combination expansion-deflection fittings shall be used where conduits cross structural expansion joints.

### PART 2 PRODUCTS

#### 2.01 MATERIALS

- A. Rigid Conduit

1. Rigid steel conduit shall be hot-dipped galvanized as manufactured by the Youngstown Sheet and Tube Company, Wheeling-Pittsburg Steel Corp., or approved equal.
  2. Rigid PVC conduit shall be Carlon Plus 80 rigid PVC non-metallic conduit (extra heavy wall EPC-80) as manufactured by Carlon, or approved equal.
  3. Electrical metallic tubing shall be hot-dipped galvanized steel as manufactured by U.S. Steel Corp., Youngstown Sheet and Tube Company, or approved equal.
- B. Liquidtight, Flexible Conduit
1. Liquidtight, flexible metal conduits shall be Sealtite, Type UA, as manufactured by Anaconda, American Flexible Conduit Co., Inc., or approved equal.
  2. Liquidtight, flexible non-metallic conduits shall be Carflex Liquidtight Flexible Non-Metallic Conduit as manufactured by Carlon, or approved equal.
- C. Rigid Conduit Fittings
1. Rigid Steel Conduit Fittings:
    - a. Steel elbows, bends, sweeps, nipples, couplings, etc., shall be hot-dipped galvanized as manufactured by Youngstown Sheet and Tube Company, or approved equal.
    - b. Conduit hubs shall be as manufactured by Meyers Electric Products, Inc., or approved equal.
  2. Rigid Non-Metallic Conduit Fittings: PVC elbows, bends, sweeps, nipples, couplings, device boxes, etc., shall be Plus 80 fittings as manufactured by Carlon, or approved equal.
  3. EMT Conduit Fittings: EMT fittings shall be hot-dipped galvanized steel, rain-tight, concrete tight, compression type, as manufactured by Crouse-Hinds, Appleton Electric Company, or approved equal.
- D. Flexible Conduit Fittings
1. Flexible Metal Conduit Fittings: Fittings used with flexible metal conduit shall be of the screw-in type as manufactured by Thomas and Betts Company, or approved equal.
  2. Flexible Non-Metallic Conduit Fittings: Fittings used with flexible non-metallic conduit shall be Carflex Liquidtight Non-metallic Fittings as manufactured by Carlon, or approved equal.
- E. Flexible Couplings: Flexible couplings shall be as manufactured by Crouse-Hinds, Appleton Electric Company, or approved equal.
- F. Wall Seals: Conduit wall seals shall be type "WSK" as manufactured by the O.Z. Electrical Manufacturing Company, or approved equal.
- G. Expansion Fittings: Combination expansion-deflection fittings shall be type "XD" as manufactured by Crouse-Hinds, or approved equal.
- H. Boxes
1. Device Boxes
    - a. Flush mounted wall device boxes shall be galvanized pressed steel as manufactured by the Raco Manufacturing Company, or approved equal.
    - b. Surfaced mounted wall device boxes shall be cast or malleable iron as manufactured by Crouse-Hinds, Appleton Electric Company, or approved equal.

- c. Flush mounted in-floor device boxes shall be cast metal, shall be watertight, shall have adjustable cover frames, and shall be as manufactured by Russell & Stoll Company, Steel City Electric, or approved equal.
  - 2. Other Boxes
    - a. Terminal boxes, junction boxes, pull boxes, etc., except as otherwise specified and/or shown on the Contract Drawings, shall be hot-dipped galvanized steel.
    - b. The boxes shall have continuously welded seams which shall be ground smooth prior to being galvanized.
    - c. The box bodies shall be flanged, shall be not less than 14-gauge metal, and shall not have holes or knockouts.
    - d. The box covers shall be not less than 12-gauge metal, shall be gasketed, and shall be fastened to the box bodies with stainless steel screws.
    - e. The boxes shall be as manufactured by Hoffman Engineering Company, or approved equal.
- I. Conduit Mounting Devices: Hangers, rods, channel, backplates, clips, straps, beam clamps, etc., shall be hot-dipped galvanized iron or steel as manufactured by Appleton Electric Company, Thomas and Betts Company, Unistrut Corp., or approved equal.
- J. Fixture Support System
  - 1. The fixture support system shall be the channel type and shall be furnished complete with all requisite mounting hardware and appurtenances.
  - 2. The channel, mounting hardware and related appurtenances shall be hot-dipped galvanized steel.
  - 3. The fixture support system shall be as manufactured by the Unistrut Corp., or approved equal.

## PART 3 EXECUTION

### 3.01 INSTALLATION

- A. No conduit smaller than 3/4-inch electrical trade size shall be used nor shall either 1-1/4-inch conduit or 3-1/2-inch conduit be used. Minimum size underground, under slab or in-slab shall be 1-inch.
- B. No wires shall be pulled until the individual conduit runs are complete in all details. Additionally, each conduit shall be cleaned and reamed and certified clear of all burrs and obstructions before any wire is pulled.
- C. The ends of all conduits shall be tightly capped to exclude dust and moisture during construction.
- D. For all galvanized steel conduits, the field-cut threads shall be thoroughly cleaned and coated with a cold galvanizing compound which contains 95% pure zinc metal. The galvanizing compound shall be as manufactured by ZRC Products Company, or approved equal. This treatment shall also be used on any nipples, elbows, etc., that are not supplied with galvanized threads.
- E. Conduits shall be supported at intervals of 8-feet or less, as required to obtain a rigid installation.
- F. Exposed conduits shall be run parallel with and/or perpendicular to the surrounding surface(s). No diagonal runs will be allowed.

- G. Single conduits shall be supported by one-hole pipe clamps in combination with one-screw backplates to provide space between the conduits and the mounting surface.
- H. Multiple horizontal runs of conduits shall be supported by trapeze type hangers (channel) suspended by threaded rod, 3/8-inch minimum diameter.
- I. Multiple vertical runs of conduits shall be supported by structurally mounted channel in combination with conduit clamps.
- J. Conduit support devices shall be attached to structural steel by welding or beam or channel clamps as indicated on the Contract Drawings.
- K. Conduit support devices shall be attached to concrete surfaces by "spot type" concrete inserts.
- L. Conduits terminating in pressed steel boxes shall have double locknuts and insulated bushings.
- M. Conduits terminating in gasketed enclosures shall be terminated with conduit hubs.
- N. Conduit wall seals, waterproof type, shall be used at all locations where conduits penetrate walls.
- O. Liquidtight, flexible conduit - metal or non-metallic as shown on the Contract Drawings - shall be used for all motor terminations and for all connections/terminations where vibration is anticipated.
- P. Flexible couplings shall be used in hazardous locations for all motor terminations and for all connections/terminations where vibration is anticipated.
- Q. Conduit stubouts for future construction shall be capped at both ends with threaded PVC conduit caps.
- R. The cement used for PVC conduit installations shall be as manufactured by Carlon, or approved equal.
- S. Galvanized steel conduits entering manholes and/or below grade pull boxes shall be terminated with grounding type bushings which shall be connected to a 5/8-inch by 10-foot long driven ground rod with No. 6 AWG bare copper wire.
- T. Galvanized rigid steel conduit shall be used for all risers. The underground portion of the riser and a 12-inch section of the riser immediately above the ground or slab/floor level shall be painted with a bitumastic coating.
- U. The use of electrical metallic tubing shall be restricted to low voltage applications (600V or less) in non-process areas where specifically approved by the owner on a "per installation" basis - e.g., above suspended ceilings in office areas.

### 3.02 GUARANTEES AND WARRANTIES

The Contractor shall guarantee and warrant all materials and labor provided under this Section in accordance with Section 01740 and Section 16050 of these Specifications.

**END OF SECTION**

## SECTION 16120 WIRES AND CABLES

### PART 1 GENERAL

#### 1.01 SCOPE OF WORK

- A. Furnish and install all wires, cables and appurtenances as described hereinafter and/or as shown on the Contract Drawings.

#### 1.02 SUBMITTALS

- A. The requirements of Section 01340 and Section 16050 shall be met.
- B. Samples of the actual wires and cables proposed for use shall be submitted for approval. There shall be a sample for each size and type of wire and cable proposed for use. The samples shall be of sufficient length to show the maximum rated voltage, insulation type and class, conductor size, the manufacturer's name, trademark or identifying logo, and the U.L. listing number.
- C. The wires and cables as approved for use shall be compared with the wires and cables actually installed. If any unapproved wires and cables are installed, they shall be removed and replaced solely at the Contractor's expense with no additional cost to the Owner.

#### 1.03 APPLICATIONS

- A. The wire for lighting and receptacle circuits shall be type THHN/THWN, solid or stranded.
- B. The wire for all power circuits and motor leads shall be type THHN/THWN, stranded.
- C. Single conductor wires for control, indication and metering shall be type THHN/THWN, No. 14 AWG, stranded.
- D. Multiconductor control cable shall be No. 14 AWG, stranded.
- E. The wire for process instrumentation shall be No. 16 AWG, stranded.

#### 1.04 MINIMUM SIZES

- A. Except for control and signal leads, no conductor smaller than No. 12 AWG shall be used.

### PART 2 PRODUCTS

#### 2.01 MATERIALS

- A. Wire and cables shall be made of annealed, 98% conductivity, soft drawn copper conductors.
- B. All conductors shall be stranded except that the uninsulated copper grounding conductors shall be solid. However, the Contractor may, at his option, install solid conductors for the lighting and receptacle circuits.

#### 2.02 600 VOLT WIRE AND CABLE

- A. Type THHN/THWN insulation shall be used for all 600 Volt wires and cables. The insulation shall be a flame-retardant, heat-resistant thermoplastic, and shall have a nylon, or equivalent, jacket.

- B. The 600 Volt wires and cables shall be as manufactured by Anixter, Rome Cable, Southwire, or approved equal.

## 2.03 INSTRUMENTATION AND CONTROL WIRING

- A. Process instrumentation wiring shall be No. 16 AWG stranded twisted pair, 600 Volt, cross-linked polyethylene insulated, aluminum tape shielded, PVC jacketed. Multiconductor cables with individually twisted pairs shall be installed where shown on the Contract Drawings.
- B. Multiconductor control cables shall be No. 14 AWG, stranded, 600 Volt, cross-linked polyethylene insulated, PVC jacketed.
- C. Instrumentation and control wiring shall be as manufactured by Belden, Alpha, or approved equal.

## 2.04 5KV CABLES

- A. All 5KV cables shall be manufactured and tested in accordance with ICEA Publication No. 5066-524 and AEIC No. 5, latest revisions.
- B. 5KV cables shall be single conductor, stranded, shielded, cross-linked polyethylene insulated, PVC jacketed, 133% insulation level, ungrounded.
- C. 5KV cables shall be as manufactured by Anixter, or approved equal.

## 2.05 5KV CABLE TERMINATIONS AND SPLICES

- A. Both ends of 5KV cables shall be terminated in accordance with IEEE Standard 48, Class 1.
- B. Terminations shall be of the preformed stress cone type, shall be approved by the cable manufacturer for use with his cable, and shall be as manufactured by Anixter, or approved equal.
- C. Unless otherwise shown or indicated on the Contract Drawing, no splices may be made in the 5KV cables without the prior written approval of the Owner.
- D. Where splicing is permitted, the splicing methods and materials shall be approved by the cable manufacturer for use with his cable and shall be as manufactured by Anixter, or approved equal.
- E. All 5KV cable terminations and splices shall be made by a qualified and certified high/medium voltage cable splicer whose qualifications shall be submitted to the Owner for approval before any work is begun.

## PART 3 EXECUTION

### 3.01 INSTALLATION

- A. Wires and cables shall be sized as shown on the Contract Drawings and/or, where applicable, sized to match existing wiring.
- B. All conductors shall be carefully handled to avoid kinks or damage to the insulation.
- C. Lubricants or pulling compounds shall be used to facilitate wire pulling. Such

lubricants/compounds shall be U.L. listed for use with the insulation specified.

- D. Use pulling means - fish-tape, cable, rope, basket weave wire/cable grips, etc. - which will not damage the wire/cable insulation or the raceway.
- E. Shielded instrumentation wire shall be installed from terminal to terminal with no splicing at any intermediate point.
- F. Shielded instrumentation wire shall be installed in rigid steel conduit and pull boxes that contain only instrumentation cables. Instrumentation cables shall be separated from control cables in manholes.
- G. Shielding on instrumentation cables shall be grounded at the transmitter end only.
- H. All new wires and cables shall be continuous and without splices between points of connection to equipment terminals. However, the Owner will permit a splice provided that the length between the connection points exceeds the greatest standard shipping length available from the submitted manufacturer and no other manufacturer acceptable to the Owner is able to furnish wires or cables of the required length.
- I. All 600 volt wire and cable connections shall be made using compression type connectors. Insulated connectors shall be used for all terminations. The connections shall be made so that both the conductivity and the insulation resistance shall be not less than that of the uncut conductor.
- J. All 5KV cable connections shall be made using approved terminators.
- K. 5KV cables exposed in manholes, vaults, pull boxes, switchgear and other areas where the cables are not protected by conduits shall be fireproofed using fireproof tape and/or glass tape in accordance with the manufacturer's recommendations and instructions. Fireproofing using asbestos tape shall not be used.
- L. All wires shall be numbered at both ends and at all intermediate junction points. Screw type terminations shall be made with forked tongue (spade), self-insulated, crimp terminals. All other wire terminations shall be made on appropriate terminal strips.

### 3.02 TESTS

- A. Upon the completion of the pulling-in of and prior to the terminating/connecting of the 600 Volt wiring, all wires shall be individually checked and tested for continuity and short circuits, and each wire/cable shall be meggered to check insulation resistance. The test voltage shall be not less than 500 Volts. Three (3) copies of these test results shall be submitted to the Owner.
- B. Similarly, the 5KV cables shall also be tested, except that a 15 minute test shall also be made using a DC voltage not less than 80% of that used for the factory tests. A plot of leakage current versus voltage shall be made and three (3) copies of the test results shall be submitted to the Owner.
- C. An authorized representative(s) of the Owner shall witness all testing. The Owner shall be notified at least two (2) days in advance of the testing.
- D. Any faulty conditions and/or shortcomings found during the testing shall be corrected at no cost to the Owner. However, a retest to demonstrate compliance shall be conducted before any hook-

ups or terminations are made. Any such requisite retesting shall be witnessed by an authorized representative(s) of the Owner.

**3.03            GUARANTEES AND WARRANTIES**

- A.    The Contractor shall guarantee and warrant all materials and labor provided under this Section in accordance with Section 01740 and Section 16050 of these Specifications.

**END OF SECTION**



## SECTION 16150 MOTORS

### PART 1 GENERAL

#### 1.01 SCOPE OF WORK

- A. Furnish, install, connect and test all motors as hereinafter specified and/or shown on the Contract Drawings. This work may necessarily include furnishing/installing, connecting and testing motors required by and/or furnished under other sections of these Specifications.

#### 1.02 SUBMITTALS

- A. The requirements of Section 01340 and Section 16050 shall be met.
- B. The Contractor shall submit to the Owner five (5) sets of the certified motor manufacturer(s) dimension drawings showing nameplate data and outline dimensions within three (3) weeks of receiving the order.
- C. The Contractor shall submit to the Owner five (5) sets of the standard motor manufacturer(s) test results (per 3.02 A) for the motors after they are constructed prior to the motors being shipped.

### PART 2 PRODUCTS

#### 2.01 RATING

- A. Motors shall be of the type and size to perform the required duty without exceeding their design ratings. Motors driving pumps shall not overload at any head or discharge condition of their respective pumps.
- B. Motors shall not be operated into their service factor range on a continuous basis as a means of supplying motors smaller than required by the specific applications.
- C. Unless otherwise specified and/or shown on the Contract Drawings, the following shall apply:
  - 1. Motors 200 HP and above shall be the medium voltage type for use at 4,160 Volts, 3-phase, 60 Hertz; motors smaller than 200 HP shall be the low voltage type. Where motors 100 HP and larger are used at 480 Volts, 3-phase, 60 Hertz, they shall be suitable for autotransformer type reduced voltage starting.
  - 2. Motors 1/2 HP through 100 HP shall be dual voltage for use at 230/460 Volts, 3-phase, 60 Hertz.
  - 3. Motors 125 HP through 199 HP shall be single voltage for use at 460 Volts, 3-phase, 60 Hertz.
  - 4. Motors smaller than 1/2 HP shall be dual voltage for use at 120/240 Volts, single phase, 60 Hertz.
- D. Use inverter duty motors with all adjustable speed drive systems. These motors shall be built with Class F or Class H insulation systems, designed to operate at 70 degrees C rise over ambient at full load, and be provided with insulated bearings. The drive system should always be located within 150 feet of the motor it is servicing.

#### 2.02 POWER FACTOR CORRECTION CAPACITORS

- A. Motors 100 HP and larger shall be furnished with power factor correction capacitors. The

capacitors shall be located in the motor controller. The motor manufacturer shall provide suitable capacitors to the motor controller manufacturer.

- B. Capacitors shall have both integral fuse protection and a discharge resistor. Capacitor current shall not exceed the motor no-load magnetizing current.
- C. Capacitor insulating media shall strictly conform to the requirements of the Environmental Protection Agency, particularly with regards to non-flammability and environmental safety.
- D. With power factor correction, motors shall have a minimum power factor of .95 at full load running conditions.

## 2.03 EFFICIENCY

- A. Medium voltage motors shall have a minimum efficiency of 95% at full load.
- B. Low voltage motors 15 HP and larger shall have a minimum efficiency of 93% at full load, 91% for TEFC motors.

## 2.04 SPACE HEATERS

- A. Motors 50 HP and larger shall have a 120 Volt, single phase space heater for moisture control. The space heaters shall be the motor manufacturer's standard wattage rating for the specific motor size and type.
- B. If a motor is on the job site longer than three (3) days prior to its final installation, the motor's space heater shall be energized and the space heater shall remain energized until such time as the motor is transported for immediate final installation.
- C. After final installation, the motor's space heater shall be energized and the space heater shall remain energized until final testing. After final testing, the motor's space heater shall be connected for normal operation.

## 2.05 CONSTRUCTION

### A. General

1. All drip proof and weather protected Type I motors shall have epoxy encapsulated windings. Non-encapsulated motors used outdoors or in specified conditions shall be totally enclosed, TENV or TEFC as specified and/or shown on the Contract Drawings. Totally enclosed motors shall be designed for severe duty.
2. Motor stators shall have copper windings. The individual steel stator laminations shall be made from quality at least as good as M22 silicon steel with a lamination thickness no greater than .019 inches. The stacking factor of the assembled stator core laminations shall be 90% or higher.
3. Squirrel cage rotor laminations shall be made from steel with quality at least as good as M22 silicon steel with a lamination thickness no greater than .019 inches. The stacking factor of the assembled rotor core shall be 90% or higher.
4. All applicable NEMA, ANSI, IEEE and U.L. standards will be strictly followed.
5. Motors shall have factory stamped stainless steel nameplates.
6. Motor frames 254T and larger shall have lifting lugs or "O" type bolts for ease in handling.

### B. Medium Voltage Motors

1. Medium voltage motors shall be of the squirrel cage induction type, shall be NEMA Design B with normal starting torque, shall be rated 4,160 Volts, 3-phase, 60 Hertz, and shall have enclosures as specified and/or shown on the Contract Drawings.
2. The stator windings shall be epoxy encapsulated, Class B or better insulation, with a maximum stator winding temperature of 90EC by resistance above a 40EC ambient when operated continuously at 115% of rated horsepower, voltage and frequency. The insulation system shall comply with all applicable NEMA standards, including the conformance test of Bulletin MG-1, 20.48.
3. The stator windings shall be provided with six (6) resistance temperature detectors (RTD=s), two (2) per phase. The RTD=s shall be at least six inches long (where core stack length permits) and inserted approximately midway in the stator slot between the coil sides. The leads shall be brought to terminals in the low voltage terminal box and labeled according to their respective RTD. The motor manufacturer shall provide any necessary relays or hardware for the RTD=s to initiate an alarm or shut the motor down in the event the RTD=s have reached a predetermined set point temperature.
4. The motors shall be equipped with both space heaters and power factor correction capacitors per Item 2.04 and Item 2.02 above, respectively.
5. The motors shall have oil lubricated thrust bearings of the spherical roller or Kingsbury type as required by the application. Minimum bearing life, in conformance with AFBMA standards, shall be ten (10) years.
6. The bearings shall be provided with RTD's, the leads of which shall be brought to terminals in the low voltage terminal box. The motor manufacturer shall provide suitable relays to the motor controller manufacturer to mount in the motor controller.
7. Bearing housings shall be equipped with sight gauges, fillers and drain plugs.
8. The high voltage terminal box shall be of adequate size to accommodate the motor lead stress cones.
9. The low voltage terminal box shall contain a terminal strip for the leads of the space heaters, stator winding RTD's, and the bearing RTD's. All wiring shall be factory installed.
10. Lightning arrestors and surge capacitors shall be provided in the motor controller by the motor controller manufacturer specified in other sections of these Specifications.
11. Medium voltage motors shall be as manufactured by General Electric Company, U.S. Motor, Ideal Electric Company, or approved equal.

C. Low Voltage, 3-Phase Motors

1. Low voltage three phase motors shall be of the squirrel cage induction types, shall be NEMA Design B with normal starting torque unless otherwise specified, shall be designed for continuous duty, with a 1.15 service factor, shall have a KVA/HP as defined by NEMA of code G or less, shall be rated per Item 2.01.C.2 and C.3 above, and as specified and/or shown on the Contract Drawings, shall have normal or high thrust bearings, and a drip proof or totally enclosed housing.
2. Motors shall have a Class B nonhygroscopic insulation system. Class F insulation may be used, but shall be limited to a Class B temperature rise.
3. The output shafts shall be suitable for either belt drive or direct connection as required by the particular application.
4. Motor frames and end shields shall be made of heavy, rigid cast iron or fabricated steel construction.
5. Motor shafts shall be made from high-grade, cold-rolled steel machined to standard NEMA dimensions.
6. Motors shall have heavy-duty precision ball bearings with a minimum AFBMA bid life of five (5) years. Bearings of high thrust motors shall be locked for a momentary upthrust of 30% downthrust.

7. Vertical hollow shaft motors shall have non-reversing ratchets to prevent backspin.
8. Totally enclosed motors shall have epoxy coated motor windings.
9. Motor conduit boxes shall be gasketed. Internal motor leads shall enter the conduit boxes through grommets.
10. All interior and exterior motor surfaces shall have a final coating of a chemically resistant corrosion and fungus protective epoxy fortified enamel finish sprayed over two (2) coats of a red primer. Stator bore and rotor shall be epoxy coated.
11. All machined surfaces shall be coated with a rust inhibitor for easy disassembly.
12. All fittings, bolts, nuts and screws shall be plated to resist corrosion. Bolts and nuts shall be hex type.
13. Low voltage, 3-phase motors shall be as manufactured by General Electric Company, U.S. Motors, or approved equal.

D. Low Voltage, Single Phase Motors

1. Single phase motors shall be either the split-phase or the capacitor-start induction types rated for the continuous horsepower at the RPM specified and/or shown on the Contract Drawings.
2. Motors shall be rated 120/240 Volts, single phase, 60 Hertz, shall have a NEMA Class B insulation system, and shall have a dripproof or totally enclosed housing as required by the particular application.
3. Motors shall have a corrosion protective finish on all internal and external surfaces. All fittings shall have a corrosion resistant plating.
4. Mechanical characteristics shall be the same as those specified above for low voltage, 3-phase motors.
5. Low voltage, single phase motors shall be as manufactured by U.S. Motors, Baldor, or approved equal.

E. D. C. Motors

1. D. C. motors shall be of the size, type, rating, duty and construction as specified and/or shown on the Contract Drawings.
2. D. C. motors shall be as manufactured by U.S. Motors, Baldor, or approved equal.

**PART 3 EXECUTION**

**3.01 INSTALLATION**

- A. Unless otherwise specified and/or shown on the Contract Drawings, all motors shall be connected to the conduit system with a short section of flexible conduit, 18-inches minimum and 60-inches maximum.
- B. Flexible conduit used for motor connections of No. 6 AWG or smaller wire shall have an approved grounding conductor incorporated inside the flexible section.
- C. For motor connections of No. 4 AWG and larger wire, the Contractor shall install an appropriately sized grounding conductor in the conduit and terminate the grounding conductor at both the motor end and the motor controller end with approved grounding clamps or connectors.

**3.02 TESTS**

- A. Prior to shipment, all motors shall be given the manufacturer's standard tests. These tests shall include, but not necessarily be limited to, the following:

1. No-Load current.
2. Air gap measurement.
3. High potential test.
4. Shaft alignment.
5. Shaft and rotor balance.
6. Bearing alignment and lubrication.

B. After installation, but prior to putting the motors into service, the Contractor shall perform the following minimum checks:

1. Motor alignment.
2. Motor clearances.
3. Bearing alignment and lubrication.
4. Correct rotation direction.
5. Megger motor windings. If insulation resistance is found to be low, the Contractor shall notify the Owner immediately and shall not energize the motor.

### 3.03 GUARANTEES AND WARRANTIES

A. The Contractor shall guarantee and warrant all materials and labor provided under this Section in accordance with Section 01740 and Section 16050 of these Specifications.

END OF SECTION

## SECTION 16152 INVERTER DUTY MOTORS

### PART 1 GENERAL

#### 1.01 SCOPE OF WORK

- A. Furnish and factory test two (2) inverter duty motors of the sizes and types hereinafter specified.

#### 1.02 MANUFACTURER'S QUALIFICATIONS

- A. The motors shall be the products of a single manufacturer who has a minimum provable history of three (3) years in the manufacturing and servicing of inverter duty motors of the sizes and types hereinafter specified.

#### 1.03 APPLICATION

- A. The motors will each be used to power a variable torque load consisting of a centrifugal pump in wastewater effluent pumping service.

#### 1.04 OPERATING CONDITIONS

- A. The motors shall be able to operate under the following environmental conditions without modification or derating:

1. Temperature: 0 to 40°C.
2. Altitude: Up to 3,300' above sea level.
3. Humidity: 0 to 95%, non-condensing.

#### 1.05 MOTOR TESTING

- A. Prior to shipment, the motors shall be subjected to the manufacturer's standard tests. The tests shall include, but not necessarily be limited to, the following:

1. No-load current.
2. Air gap measurement.
3. High potential test.
4. Shaft alignment.
5. Shaft and rotor balance.
6. Bearing alignment and lubrication.

- B. The manufacturer shall certify that the motors are an improved design meeting the requirements of NEMA MG 1, Part 31 for motor insulation systems - i.e., a peak voltage of 1600 V and a time rise of 0.1 microsecond; specifically, motors that do not meet both the peak voltage level and the time rise limitation will not be acceptable under this Specification.

#### 1.06 APPROVED EQUAL

- A. The Owner shall be the sole determiner of what constitutes an "approved equal" product.

#### 1.07 SUBMITTALS

- A. Within three (3) weeks of receiving the order and prior to start of fabrication of the motors, the

motor manufacturer shall furnish the Owner with five (5) sets of motor drawings for review and approval. The results of the manufacturer's standard post-manufacturing test results (per 3.01 A) for the motors shall be submitted prior to shipment.

- B. The motor drawings shall include, but not necessarily be limited to, motor nameplate data, motor mounting base dimensions, motor dimensions and weight, and the location and size of both the motor leads terminal box and the low voltage leads terminal box. Information shall be sufficiently detailed to allow for locating conduit stub-ups.
- C. Failure to comply with Item 1.07A above shall be entirely at the manufacturer's risk. Any changes required as a result of the Owner's review will be solely at the manufacturer's expense with no cost to the Owner.

## 1.08 WARRANTY

- A. The manufacturer shall warrant that the motors shall be free from defects in all materials and workmanship for a period of two (2) years from date of final acceptance, or for the duration of the manufacturer's standard warranty, whichever period is longer.
- B. During the warranty period, any and all covered defects shall be corrected by the manufacturer solely at his own expense with no cost to the Owner.

## PART 2 PRODUCTS

### 2.01 INVERTER DUTY MOTORS

#### A. GENERAL

1. The motors shall be of the type and size to perform the required duty without exceeding their design ratings. The motors shall not overload at any head or discharge condition of their respective pumps.
2. The motors shall be suitable for use on a 480 Volt, 3-phase, 60 Hz power system.
3. The motors shall have a 1.15 service factor. The motors shall not be operated into their service factor range on a continuous basis as a means of supplying motors smaller than that required by the specific applications.
4. The motors shall have a minimum efficiency of 93% at full load.
5. The motors shall each be equipped with a 120 Volt, single phase space heater for moisture control. The space heaters shall be the motor manufacturer's standard wattage rating for the size and type of motors actually furnished.
6. The motors shall have minimum power factors of 93% at full load and 95% when partially loaded. The motor manufacturer shall furnish the required power factor correction packages (capacitors, fuses, discharge resistors, etc.) to the Owner for installation in the motor controller enclosures. Capacitor currents shall not exceed the no-load magnetizing currents of the motors. The capacitor insulating media shall strictly conform to the requirements of the Environmental Protection Agency, particularly with regard to non-flammability and environmental safety.

#### B. CONSTRUCTION

1. The motors shall be NEMA B, vertical types specifically designed and fabricated for AC inverter usage (PWM type) and adjustable speed applications. Motors which must be used with one particular brand of inverter to achieve compliance will not be acceptable under this Specification.

2. The motors will be coupled to centrifugal pumps which will be used to pump a liquid consisting of wastewater effluent having a specific gravity of 1.0 at a nominal ambient temperature of 76EF.
3. The motors shall be a normal torque, low slip design.
4. One motor shall be rated 150 HP at 1800 RPM and will drive a centrifugal pump with a maximum output of 2600 GPM against a TDH of 154'. The other motor shall be rated 300 HP at 1200 RPM and will drive a centrifugal pump with a maximum output of 4000 GPM against a TDH of 223'.
5. All applicable NEMA, ANSI, IEEE, and U.L. standards and procedures shall be strictly followed in the design and fabrication of the motors. The motors shall be U.L. listed.
6. The motors shall have insulation systems designed to meet the voltage spike limits as defined in NEMA MG 1, Part 31, 1993. Complete insulation of the slot, cell, and phase groups is required. The insulation systems shall be rated for Class F temperature rise or better. Insulation systems utilizing heavy film and two film wire with a Pulse Endurance Index of less than 50 will not be acceptable under this Specification.
7. The motor windings shall be epoxy encapsuled and shall utilize copper wires. Aluminum motor windings will not be acceptable under this Specification.
8. The motors shall be furnished with TEFC enclosures designed for severe/corrosion duty. Motor enclosures shall be fabricated of cast iron or rolled steel and shall be provided with a condensate drain hole. Aluminum motor enclosures will not be acceptable under this Specification.
9. The squirrel cage rotors shall be made from high grade steel laminations tightly fastened together and securely affixed to the motor shaft. Steel bar type construction with steel ends rings is also acceptable. Aluminum rotors of any type will not be acceptable under this Specification.
10. The stator cores shall be made from high grade steel and shall utilize reinforced end turn construction for high rigidity, minimum winding mechanical fatigue, and low resonant noise level. Aluminum stator will not be acceptable under this Specification.
11. The stator windings shall be provided with six (6) resistance temperature detectors (RTD's), two (2) per phase. The leads of the highest reading detector as determined by factory test shall be brought to terminals in the low voltage terminal box. The motor manufacturer shall provide suitable relays to the Owner for mounting in the motor controller enclosures.
12. The temperature rise of the motors shall not exceed Class F insulation limits, with an allowable winding hot spot temperature of 115EC when operated on inverter power across the motors' nameplate speed and torque envelope. Sine wave temperature rise shall be Class F or better.
13. The motors shall be equipped with both space heaters and power factor correction capacitors per Item 2.01.A.5 and Item 2.01.A.6 above, respectively.
14. The motors shall be fitted with oil lubricated high thrust bearings of the type (spherical



roller, ball or Kingsbury) required by the specific application. The bearings shall be locked for a momentary upthrust of 30% downthrust. Minimum bearing life shall be five (5) years as determined in accordance with AFBMA standards.

15. The bearings shall be provided with RTD's, the leads of which shall be brought to terminals in the low voltage terminal box. The motor manufacturer shall provide suitable relays to the Owner for mounting in the motor controller enclosures.
16. Bearing housings shall be equipped with sight gauges, fillers, and drain plugs.
17. The motors shall be equipped with two (2) gasketed conduit boxes - a high voltage terminal box of adequate size to accommodate the motor leads and a low voltage terminal box with a terminal strip for the leads of the space heaters, the stator winding RTD's, and the bearing RTD's. The wiring, which shall be factory installed and tested, shall enter the terminal boxes through grommets.
18. The motor shafts shall be solid (150 HP) or hollow (300 HP) vertical types, shall be fabricated from stainless steel, shall have standard NEMA dimensions, shall have non-reversing ratchets to prevent backspin, and shall be suitable for direct coupling to the driven pumps. The motor manufacturer shall furnish to the Owner suitable couplings of the bolted type (150 HP) and the screw (threaded) type (300 HP) to couple the motors with their respective pumps.
19. The motors shall be furnished with permanently attached stainless steel nameplates containing the requisite NEC, NEMA data. In addition, the motor manufacturer shall expand his standard nameplate or add an additional permanently attached stainless steel data plate containing, as a minimum, the following adjustable speed performance information:
  - a. Application Type - Variable Torque.
  - b. Maximum approved continuous torque.
  - c. Approved speed (RPM) range.
  - d. Approved frequency (Hz) range.
  - e. Motor full load current (Amps) on inverter power.
20. All fittings, bolts, nuts, and screws shall be plated to resist corrosion. Bolts and nuts shall be Hex type.
21. The motor frames shall have lifting lugs or "O" type bolts for ease in handling.
22. All interior and exterior motor surfaces shall have a final coating of a chemically resistant corrosion and fungus protective epoxy fortified enamel finish sprayed over two (2) coats of a red primer. The stator core and the rotor shall be epoxy coated.
23. All machined surfaces shall be coated with a rust inhibitor for easy disassembly.
24. The motors shall be "Inverter Grade" products as manufactured by U.S. Electrical Motors, or approved equal.

## **PART 3 EXECUTION**

### **3.01 FACTORY TESTING**

- A. Prior to shipment, the motors shall be tested in accordance with Item 1.05.A above.
- B. After successfully completing the tests of Item 3.01.A above, the motors shall be tested and evaluated on inverter power over the approved speed range. Computer simulation of motor inverter operation is an acceptable alternative to actually connecting the motors to an inverter.
- C. During the testing, the major motor parameters shall be recorded and the test results shall be forwarded to the Owner for review and approval prior to shipment of the motors.

**3.02 SHIPPING**

- A. The motors shall be so packaged for shipment that they are maximally protected from both physical and environmental damage.
- B. The motors shall be transported to the Owner's job sites utilizing the manufacturer's customary method of shipment.

**3.03 INSTALLATION**

- A. The motors shall be installed by the Owner's personnel in accordance with the recommendations and procedures set forth in the installation manuals furnished by the manufacturer.
- B. An authorized factory trained representative(s) of the manufacturer shall be available to assist the Owner's personnel on an "as needed" basis.

**3.04 WARRANTY**

- A. The manufacturer shall furnish to the Owner a written warranty which complies with the requirements of Item 1.08 above.

**END OF SECTION**

## SECTION 16160 PANELBOARDS

### PART 1 GENERAL

#### 1.01 SCOPE OF WORK

- A. Furnish all labor, materials, equipment, devices, and incidentals required and install all panelboards as hereinafter specified and/or as shown on the Contract Drawings.

#### 1.02 SUBMITTALS

- A. The requirements of Section 01340 and Section 16050 shall be met.

### PART 2 PRODUCTS

#### 2.01 RATING

- A. All panelboards shall be rated for the intended voltage. Panelboard ratings shall be as shown on the Contract Drawings.
- B. Panelboards shall be U.L. listed.

#### 2.03 CONSTRUCTION

##### A. Interiors

1. Interiors shall be completely factory assembled with main breakers, bus bars, branch circuit breakers, wire connectors, etc.
2. All wire connectors, except screw terminals, shall be of the anti-turn solderless type.
3. All wire connectors shall be suitable for use with copper wires of the size(s) indicated on the Contract Drawings.
4. Branch circuits shall be arranged using double row construction except where narrow column panels are called for on the Contract Drawings.
5. Branch circuits shall be numbered by the panelboard manufacturer.
6. Interiors shall be so designed that circuits may be changed without machining, drilling or tapping; without disturbing adjacent units; and without removing the main bus connectors.
7. Interiors shall be durably marked by the manufacturer with the voltage, current rating and number of phases for which the panelboards are designed. The markings, which shall be visible after installation without disturbing the interior parts or wiring, shall also include the manufacturer's name or trademark.
8. All current carrying parts, including cross connectors, shall be copper.

##### B. Bus Bars

1. The bus bars for the mains shall be sized as shown on the Contract Drawings.
2. Both a full-capacity neutral bus and a separate ground bus shall be provided. Neutral bus bars shall have a suitable lug for each outgoing feeder requiring a neutral connection.
3. Phase bus bars shall be full height without reduction.
4. Bus bar taps for panelboards with single pole branches shall be arranged for sequence phasing of the branch circuit devices.
5. Bus bars shall be braced to conform to industry standards for short circuit stresses in panelboards.

C. Circuit Breakers

1. The panelboards shall be equipped with circuit breakers, main and branch, with trip settings as shown on the Contract Drawings.
2. The circuit breakers shall be of the molded case, bolt-on type with the number of poles as shown on the Contract Drawings.
3. Circuit breakers used in 120/240 Volt and 120/208 Volt panelboards shall have a minimum interrupting rating of 10,000 Amperes RMS symmetrical.
4. Three-pole circuit breakers used in 480 Volt panelboards shall have a minimum interrupting rating of 14,000 Amperes RMS symmetrical.

D. GFCI (Ground Fault Circuit Interrupter)

1. GFCI units shall be provided for all circuits where shown on the Contract Drawings.
2. The GFCI units shall be 1-pole, 120 Volt, molded case, bolt-on circuit breakers incorporating a solid state ground fault interrupter circuit which shall be insulated and isolated from the breaker mechanism.
3. The GFCI units shall be U.L. listed Class A, Group I devices (5 milliamp sensitivity, 25 millisecond trip time), and shall have an interrupting capacity of 10,000 Amperes RMS symmetrical.

E. Enclosures, Covers and Trim

1. The enclosures shall be of the NEMA Type (1, 3R, 4, 4X, 12), material (code gauge steel, stainless steel, fiberglass), and mounting configuration (flush, surface) as shown on the Contract Drawings.
2. Enclosures shall be of sufficient size to provide a minimum 4-inch gutter space on all sides. At least four (4) interior mounting studs shall be provided for each enclosure. Enclosures shall be furnished without conduit knockouts. Enclosures shall have hinged doors which cover all circuit breaker handles.
3. Stainless steel enclosures and covers shall have a natural metal finish. Enclosures and covers shall be joined together with a concealed piano type stainless steel hinge. Conduit openings in the enclosures shall be field drilled and, if applicable, tapped.
4. Fiberglass enclosures and covers shall be the manufacturer's standard color. Enclosures and covers shall be joined together with a concealed piano type stainless steel hinge. Conduit openings in the enclosures shall be field drilled and, if applicable, tapped.
5. Code gauge steel enclosures and covers shall be galvanized steel finished as per Item 2.03.E.7 below. Enclosures and covers shall be joined together with a concealed piano type hinge. Conduit openings in the enclosures shall be field punched.
6. Code gauge steel enclosures shall have panel trims of code gauge sheet steel. Trims for flush mounted enclosures shall overlap the enclosures by at least 3/4-inch all around. Surface mounted enclosures shall have trims the same height and width as the enclosures. Trims shall be fastened to the enclosures with quarter-turn clamps or screws.
7. All interior and exterior surfaces of the panelboards, enclosures and trims shall be properly cleaned, painted with a rust inhibitor (two coats), and over-coated with ANSI Z55.1, No. 61 light gray paint. The finish paint shall be of a type to which field applied paint will adhere.
8. The inside surface of each cover shall have a directory frame with a transparent cover and a directory card.
9. Covers shall have semi-flush type cylinder locks and catches, except that covers over 48-inches in height shall have vault handles and 3-point catches, complete with lock, arranged to fasten at top, bottom and center. Two (2) keys shall be furnished for each

lock and all locks shall be keyed alike.

F. Manufacturer

1. 120/240 Volt and 120/208 Volt panelboards shall be type NQOD with QOB bolt-on circuit breakers as manufactured by the Square "D" Company, or approved equal.
2. 480 Volt panelboards shall be the I-Line type as manufactured by the Square "D" Company, or approved equal.

**PART 3 EXECUTION**

**3.01 INSTALLATION**

- A. Surface mounted panelboards shall be installed using spacers so that there is an air space between the enclosure and the mounting surface.
- B. Unless otherwise shown on the Contract Drawings, the tops of the enclosures shall be mounted at a height of 6-feet above the floor. The enclosures shall be properly aligned, true-and-square, and shall be adequately supported independently of the connecting conduits.
- C. All panelboard wiring shall be neatly formed, grouped, laced, and identified to provide a neat and orderly appearance.
- D. The Contractor shall type on the directory card the description/use of each active circuit. "Spare" shall be indicated in erasable pencil!

**3.02 TESTS**

- A. Each individual circuit breaker, including the main breaker and the GFCI breaker(s), shall be tested for proper operation under the appropriate overload/ground fault conditions.

**3.03 GUARANTEES AND WARRANTIES**

- A. The Contractor shall guarantee and warrant all materials and labor provided under this Section in accordance with Section 01740 and Section 16050 of these Specifications.

**END OF SECTION**

**SECTION 16231 DIESEL GENERATOR SET**

**PART 1 GENERAL**

**1.01 SCOPE**

- A. Provide and install complete and operable UL 2200 listed emergency/standby electric generating systems for lift stations which contain all the devices and equipment specified herein and/or required for the service. Equipment shall be new, factory and field tested, installed, and ready for operation.
  
- B. The diesel engine is to be of sufficient horsepower to drive the generator under full load conditions. It shall be 4-cycle, fueled via an adjacent or sub-base fuel tank and cooled with a closed looped radiator system. The generator is to be a low reactance brushless generator, with torque matched excitation and automatic voltage regulation. There is to be a set-mounted control panel with vibration insulators between it and the diesel generator set. The generator, controls and associated cooling and exhaust systems specified in these specifications are to be housed in a suitable weather protected enclosure which is to be permanently installed outdoors. The automatic transfer switch may be installed in the generator enclosure or be installed in a separate NEMA 3R enclosure.
  
- C. Where conflict between drawings, specifications or code occurs, the Contractor shall assume and provide the more stringent of the alternatives to the County.

**1.02 RATINGS**

- A. Generator set at site number 1 is to be installed at:

\_\_\_\_\_  
\_\_\_\_\_  
\_\_\_\_\_, Florida

This generator set is to be of suitable power to drive a total of \_\_\_ submersible \_\_\_ volt, \_\_\_ horsepower induction motor pumps. This site shall have a(n) adjacent / sub-base fuel tank. Enclosure shall be wind rated to \_\_\_\_\_ mph.

- B. The generator set at site number 2 is to be installed at:

\_\_\_\_\_  
\_\_\_\_\_  
\_\_\_\_\_, Florida

This generator set is to be of suitable power to drive a total of \_\_\_ submersible \_\_\_ volt, \_\_\_ horsepower induction motor pumps. This site shall have a(n) adjacent / sub-base fuel tank. Enclosure shall be wind rated to \_\_\_\_\_ mph.

PLEASE NOTE : The induction pump motors providing the loads at the above sites all have the following characteristics and the diesel generator sets supplied with this contract are to be built and sized bearing these facts in mind:

- 1. NEMA LRA Code H
- 2. Started with full voltage starters-maximum allowable voltage dip at start is 20%-loading

- will be sequential, (i.e., after each pump is brought up to speed the next one will be started)
3. 240 or 480 VAC (as required in the above sites)
  4. 3 Phase
  5. 60 HZ.

ALSO: Each generator is to be built with the following characteristics/conditions:

1. Generator sized as a sequence load.
2. Standby Emergency Rating
3. Power Factor = .8
4. Site Altitude = 100 feet
5. Range of Site Ambient Temperatures = 20 - 120° F.

### 1.03 DIESEL GENERATOR SET PERFORMANCE

- A. The voltage regulation of each set shall be  $\pm .5\%$  of rated voltage for any constant load from the range of no load to full rated load.
- B. The frequency regulation of each set shall be accomplished through an isochronous electronic governor from the range of steady state no load to steady state full rated load.

### 1.04 MANUFACTURERS

- A. Subject to compliance with requirements stated and defined in these specifications, the following are approved manufacturers of the diesel generator sets:
  1. Kohler Co.
  2. Caterpillar, Inc.
  3. Baldor
  4. Generac
  5. Katolight
  6. Approved equal to the above manufacturers- approval is granted if all of the following conditions are met:
    - a. The manufacturer meets or exceeds all the specifications of this document
    - b. The components of their systems are of equal or better quality than the above specified manufacturers
    - c. The manufacturer has an experience level in the product line that is provided that is equal to or greater than the above specified manufacturers.

### 1.05 SUPPLIER

- A. The complete package - engine, generator, automatic transfer switch and other auxiliary components specified in this section shall be provided from a single manufacturer, except for the fuel tank. The supplier shall be the manufacturer's authorized distributor who shall maintain a service center capable of emergency maintenance and repairs with a maximum of four hours response time. The supplier shall have 24 hour/365 days per year service availability and factory trained service technicians authorized and capable to perform warranty service on all warrantable products.

### 1.06 SUBMITTALS

- A. As a minimum for all equipment specified and provided, for each site, submit the following:

1. Specification and application data sheets for the entire system supplied.
2. Shop drawings showing a dimensioned outline plan and elevation views of the system with certified overall and interconnection point dimensions. Indicate fabrication details, dimensions, weights, loads, required clearances, components, location and size of each field connection and method of field assembly.
3. Site plan showing foundation slabs & underground conduit locations along with all existing facilities on site, distance to nearest habitable structure and overhanging trees.
4. Shop drawings of connections details of generator, fuel tank and automatic transfer switch enclosure connections to foundation slabs. Illustrate all necessary mounting bolts, any conduit requirements in the foundation, etc
5. Manufacturer's installation instructions.
6. Interconnection wiring and piping diagrams which show all external connections required. Show field wiring terminals with markings in a consistent point to point manner.
7. Manufacturer's certification of prototype testing which show evidence of compliance with specified requirement.
8. Manufacturer's applicable published warranty documents.
9. Time vs. current characteristic curves for generator's protection devices.
10. Thermal damage curve for generator.

The above documents shall be provided to Manatee County within two weeks of contract award. No equipment is to be purchased until the submittal is approved.

B. Prior to acceptance of the generator at each site by the County:

1. Generator field test results showing compliance with the specifications.
2. Signed and sealed concrete foundation slab drawings
3. Signed and sealed final site plan showing all existing and new above ground facilities / improvements, new underground conduit and fuel line locations, and property corners.

## 1.07 WARRANTY

- A. A comprehensive, no deductible warranty shall be supplied for the complete electrical power system (the generator set, controls and associated switches, switchgear, automatic transfer switch and all accessories) supplied for each installation. The complete systems shall be warranted by the manufacturer against defects in materials and workmanship for a period of five years or 1500 hours of operation; whichever occurs first from the date of system startup. This warranty coverage shall include parts, labor, and travel expenses.
- B. The warranty of the coating of the enclosure and fuel tank shall be a non-deductible, unlimited warranty against rust and corrosion for a period of ten years.

## PART 2 PRODUCTS - AT EACH SITE:

### 2.01 AC GENERATOR

- A. Each generator shall be:
1. Used for 60 Hz Operation, 240 Volt or 460 Volt output voltage
  2. 4- Pole - 1800 RPM - Revolving Field Synchronous Machine
  3. Stator Winding to be .667 Pitch
  4. Air Cooled by Shaft Mounted Fans
  5. 12 Leads for Output Connections



6. Class H Insulation System
  7. Temperature Rise by Resistance not to Exceed 125° C at Full Load
  8. The stator shall have vacuum impregnated windings with fungus resistant epoxy varnish.
- B. Utilize a permanent magnet generator for excitation power to an automatic voltage regulator. The permanent magnet generator shall sustain main field excitation power for optimum motor starting and to sustain short circuit current for selective operation and coordination of system over current devices.
- C. The automatic voltage regulator shall be a temperature compensated solid state design. It shall be equipped with 3-phase RMS sensing. The regulator shall control buildup of AC generator voltage to provide a linear rise and limit overshoot. The regulator shall include an under frequency rolloff torque-matching characteristic which shall reduce output voltage in proportion to frequency below a threshold of 58 hz. The torque matching characteristic shall include differential rate of frequency change compensation to use maximum available engine torque and provide optimal transient load response. Regulators which use a fixed voltage per hz. characteristic are not acceptable.
- D. Provide a generator main circuit breaker. This breaker is to be set mounted and wired, molded case thermal-magnetic rated for proper generator set operation. The breaker shall be UL listed. Field circuit breaker shall not be acceptable for the purpose of generator overcurrent protection. The generator circuit breaker shall incorporate:
1. Tripping characteristic: designed specifically for generator protection.
  2. Trip rating is to be matched to generator rating.
  3. Shunt Trip: Connected to trip breaker when generator set is shut down by other protective devices.
  4. Mounting Position: Adjacent to or integrated with control and monitoring panel.
- E. Provide a microprocessor-based unit that will continuously monitor current level in each phase of generator output. When signaled by the protector or other generator set protective device, a shunt-trip device in the generator disconnect switch shall open the switch to disconnect the generator from the load circuits. This microprocessor-based unit shall also:
1. Initiate a generator overload alarm when the generator has operated at an overload equal to 110% of full load for 60 seconds.
  2. Under single or three phase fault conditions, it shall regulate the generator to 300% or rated full load current for up to 10 seconds.
  3. When the heating effect of overcurrent on the generator approaches the thermal damage point of the unit, the processor shall switch the excitation system off and open the generator disconnect switch to shut the generator down.
  4. Sense the clearing of a fault by other overcurrent devices and control the recovery of the rated voltage to avoid overshoot.
- F. Leads for water jacket heaters and space heaters shall be housed in their own separate conduit box.
- G. Provide alternator strip heater or thermostatically controlled space heater(s) per manufacturer's recommendation to keep moisture out of the windings.

## 2.02 INSTRUMENTATION AND CONTROL

- A. Each diesel generator set is to be capable of being started and shutdown through an

automatic transfer switch or manually.

- B. Manually, the control shall have automatic remote start capability from a panel mounted three position (Stop, Run, Remote) switch. When the control panel is selected to the "Run" position, the generator set starts and runs. When selected to the "Stop" position, a shutdown is initiated. The "Remote" position allows the set to be operated from a remote location.
- C. An emergency stop button will also be installed to shut the system down. This button should be a minimum of two inches in diameter painted red, labeled "STOP" and installed in a conspicuous location on the diesel generator set. It shall be reusable and resettable.
- D. The control shall shut down and lock out upon: failing to start (overcrank), overspeed, low engine oil pressure, high engine coolant temperature, or operation of a remote manual stop station. A panel mounted switch shall reset the engine monitor and test all the lamps. Lamp indications on the control panel shall include as a minimum:
  - 1. Overcrank Shutdown - Red
  - 2. Overspeed Shutdown - Red
  - 3. High Coolant Temperature - Red
  - 4. Low Engine Oil Pressure - Red
  - 5. High Engine Coolant Temperature Prealarm - Yellow
  - 6. Low Engine Oil Pressure Prealarm - Yellow
  - 7. Low Fuel - Yellow
  - 8. Run - Green
- E. Each diesel generator set is to be set up by the manufacturer to indicate to a remote location through the County's RTU system:
  - 1. When diesel generator set is in operation.
  - 2. When generator fails (no commercial or generator power).

The County's RTU system uses discrete-type signals with N/O type contacts.

- F. All basic system controls, operating and annunciating indicators, generator meters, engine gage and associated transformers, disconnect switches and circuit breakers are to be mounted in a NEMA 1 enclosure control panel on the generator set base through vibration isolators.
- G. Regulation of NFPA 110 Level 2 shall apply for instrumentation, alarm and shutdown. The instrument panel shall include, but not necessarily be limited to:
  - 1. Gages for diesel engine: digital or analog gages with  $\pm 2\%$  full scale accuracy:
    - a. Oil Pressure
    - b. Engine Coolant Temperature
    - c. Voltmeter for the DC Battery
  - 2. Gages for generator: digital or analog gages with  $\pm 2\%$  full scale accuracy:
    - a. AC Ammeter - dual range
    - b. AC Volt Meter - dual range
    - c. Frequency Meter - range of 45-65 Hz.
  - 3. Elapsed Time Meter
  - 4. 0-3000 RPM Tachometer - digital or analog gage with  $\pm 2\%$  full scale accuracy.
  - 5. A seven position phase selector switch with AOFF@ position to show meter display of current and voltage of each generator phase. This selector switch may be manual or

- push-button.
- 6. A power source with circuit protection - 12 or 24 VDC.
- 7. An AC interlock to prevent starter re-engagement with engine running.
- 8. DC circuit protection.
- 9. A minimum of two panel lamps to illuminate instrument panel.

H. Switches and Controls

- 1. Rheostat for adjusting output voltage of the generator to  $\pm 5\%$  of nominal voltage.
- 2. Over voltage protection shutdown switch.
- 3. Emergency stop switch mounted on control panel.
- 4. Engine start switch - with Run, Off, Reset, Automatic positions.
- 5. Five minute engine cool down timer.
- 6. Cyclic cranking switch.

I. Contractor shall install three wire pairs from the generator control panel to the existing RTU control panel: generator running, generator failed, and a spare pair. County shall make the actual connections to the RTU system.

J. All electrical penetrations in any enclosure shall be properly sealed from the weather.

## 2.03 ENCLOSURE

A. The diesel generator set and all the equipment supplied in this contract, shall be operated in a stationary outdoor environment. At each site, it shall:

- 1. Require weather protected enclosures. These enclosures shall protect the diesel generator unit and all equipment and devices supplied in this contract from the elements of the weather to include rain and winds to the required wind withstanding protection as defined by applicable governmental codes and regulations in the area. The equipment supplied shall be housed in two separate enclosures- one for the diesel generator set and its related devices and another for the automatic transfer switch. All enclosures, boxes, trays, etc shall have weep holes for condensation or water intrusion drainage.
- 2. The generator enclosure shall provide adequate ventilation for cooling and operation under full load conditions. Openings shall be screened or sized to pass a sphere no larger than  $\frac{1}{2}$ "D.
- 3. The generator enclosure shall be constructed of 14 gauge steel. The enclosure shall have an electrostatically applied, baked on, powder coated enamel finish 1.5 to 2.5 mil. This coating shall have a non-deductible, unlimited warranty against rust and corrosion for a period of ten years. The color of the coating shall be a "buff" color and must be approved by Manatee County prior to installation of the product.
- 4. The side panels shall be easy to remove to allow access to all areas of the diesel generator.
- 5. The housing shall have hinged side access doors and a rear control door. All doors shall be provided with padlock hasps so that the County can install their standard padlocks. All handles, hinges, hasps, and all mounting bolts and screws shall be stainless steel and tamper-proof.
- 6. The housing shall be factory assembled to the generator set skid base. The skid base shall be firmly fastened to a concrete foundation which is to be provided and installed as part of this contract.
- 7. The diesel engine and generator shall be removable from the base for maintenance purposes.
- 8. The skid is to have adequate strength and rigidity to maintain alignment of mounted

components without depending on the concrete foundation. Lifting attachments shall be arranged to facilitate lifting with slings without damaging any components.

9. The base shall incorporate a battery tray with battery hold down clamps within the rails. Provisions for stub up of electrical conduits shall be within the footprint of the set. Vibration isolation shall be integral between the generator set and base.
10. The enclosure shall be a low noise or sound attenuated enclosure. The noise level at any load operating condition, in any direction from the enclosure, shall not exceed 75 dBA at a distance of five (5) meters from the enclosure unless noted otherwise on the plans

## 2.04 ENGINE

- A. The engine at each site, shall be a 4-cycle, suitable for 1800 RPM continuous operation, direct injection diesel with forged steel crankshaft and connecting rods. It shall be designed for stationary applications and shall be complete with all necessary auxiliaries needed for operation of the AC generator.
- B. The engine shall be cooled by a closed loop radiator system rated for full load operation in a 50° C ambient. See the Cooling System section for further details.
- C. The engine shall have an electronic governor which shall provide isochronous frequency regulation. The governor shall have provision for paralleling with the addition of load sharing controls.
- D. The engine shall have an electric starter and battery(ies). See the Starting System section for further details.
- E. Provide full flow lubrication oil filters with replacement spin-on canister elements. Provide a dipstick for oil level indication and an easily accessible fill location.
- F. Supply a fuel/water separator and filter. See the Fuel System section for further details.
- G. Supply a replaceable dry element air cleaner with restriction indicator.
- H. Provide an engine mounted thermostatically controlled water jacket heater. The heater(s) wattage size shall be determined by the manufacturer. The heater voltage shall be single phase, 120V, 60HZ.

### 2.04.1 STARTING SYSTEM - ENGINE

- A. The battery(ies) used for cranking the diesel generator shall be the lead acid type, 12 or 24 volt, sized as recommended by the generator manufacturer. The battery(ies) shall have sufficient capacity to crank the diesel engine for at least three cycles of 15 seconds on - 15 seconds off, for a total of 75 seconds. They shall be provided as new with the entire manufacturer's warranty.
- B. The battery(ies) shall be fastened securely in its(their) own tray within the foot print of the skid. The tray shall be acid resistant.
- C. Include all interconnecting conductors and connection accessories.
- D. A battery charger of appropriate rating which is voltage regulated, shall be provided for the diesel generator set. It shall be sized for the proper current, input AC voltage and output DC

voltage. The charger shall be equipped with float, taper and equalize charge settings.

- E. A meter on the charger shall provide a visual output reading of the charger.
- F. On the engine, provide a factory mounted alternator with solid state voltage regulation and 35 Amp minimum continuous rating.

#### 2.04.2 FUEL SUPPLY SYSTEM- ENGINE

- A. Provide a double walled fuel tank, made of heavy gauge construction that is designed for full weather exposure. Depending on the site, the tank may either be the stand-alone or sub-base type. There is to be visual tank to foundation clearance. The tank is to have the following features:
  - 1. Tank shall be UL 142 listed.
  - 2. The capacity of the fuel tank shall be sufficient to run the generator continuously for 96 hours at 75% load up to a maximum of 540 gallons.
  - 3. Equipped with a mechanical fuel gage and low fuel level alarm that may be monitored from a remote location by a RTU which uses N/O type contacts.
  - 4. Two inch NPT fuel opening with spill protection and a lockable lid which is easily accessible.
  - 5. Emergency pressure relief vent opening on the inner and outer tanks.
  - 6. Inner tank leak alarm kit that may be monitored in some remote location by an RTU.
  - 7. Basin drain.
  - 8. Overfill protection / containment.
  - 9. Provide an integral fuel pump of sufficient capacity to sufficiently charge the fuel lines under any start or run condition.
  - 10. The exterior shall have an electrostatically applied, baked on, powder coated enamel finish 1.5 to 2.5 mil. This coating shall have a non-deductible, unlimited warranty against rust and corrosion for a period of ten years. The color of the coating shall be a "buff" color, matching the generator enclosure.
- B. The overall fuel system is to comply with all applicable NFPA regulations as well as those required by the Florida Department of Environmental Regulation.
- C. Provide an anti-siphon valve in the fuel line at the output of the tank.
- D. A fuel filter shall be installed between the fuel tank and fuel inlet to the engine. It shall have a fuel water separator. The filter element shall be disposable and be easily removed and installed for maintenance purposes.
- E. Provide supply and return fuel lines of sufficient diameter for all load requirements, flexibility for maximum resistance to fatigue due to component operation and made of material which has maximum resistance to corrosion due to environment and fuel supply.
- F. The skid base for the fuel tank shall be firmly fastened to a concrete foundation which is to be provided and installed as part of this contract. The fuel tank & skid assembly shall be removable from the base. Lifting points shall be provided for the tank skid.

#### 2.04.3 COOLING SYSTEM- ENGINE

- A. The engine shall be cooled by a unit mounted closed loop radiator system rated for full load

operation in 50° C ambient condition with the ambient temperature as measured at the air inlet to the radiator. Radiator shall be provided with a duct adapter flange. The cooling system shall use a 50/50 (Prestone, Xerex or equivalent coolant and water) mixture provided by the supplier.

- B. Provide drain cocks or plugs in the engine block and radiator for easy changing and flushing of the coolant. Provide coolant drain extensions where necessary for easy access to the drainage device.
- C. Provide a coolant heater which is thermostatically controlled in the jacket of the engine. See paragraph 2.04 H.

#### 2.04.4 EXHAUST SYSTEM- ENGINE

- A. The muffler for the diesel engine shall be the critical grade made from aluminized steel of thickness and design as recommended by the manufacturer. The muffler shall be housed within the generator enclosure.
- B. All exhaust piping shall be stainless steel. Vertical discharge exhaust shall be equipped with a rain cap, appropriate condensation drains in the piping, and the outlet, and shall be designed so no external rain or moisture may enter the engine from the outside even if the rain cap fails. Care must be exercised so there is no recirculation of exhaust gases into the intake system.
- C. The connection of the engine to the exhaust system shall be a flexible section of corrugated stainless steel pipe. The connection of the exhaust pipe to the muffler shall be a stainless steel expansion joint with liners. The connection of the muffler to the end of the system shall be stainless steel pipe.
- D. The exhaust emissions shall fall within the guidelines of the EPA and other state and governmental agencies.

#### 2.05 AUTOMATIC TRANSFER SWITCH

- A. Supply an automatic transfer switch at each site with built-in control logic monitors to sense any interruption in the utility supplied power. When the power fails, the automatic transfer switch starts the engine and transfers the load after the generator has reached proper voltage and frequency. When the utility power has been restored to the proper voltage and frequency, the automatic transfer switch will switch the load back to the utility source and after a time delay to sufficiently cool down the generator, shut down the engine. The utility power service size to each site shall be verified by the contractor and shall be factored in when determining the size of the automatic transfer switch.
- B. The automatic transfer switch may be housed within the generator enclosure or in a separate NEMA 4x SS enclosure installed on a concrete pad. The enclosure shall have an electrostatically applied, baked on, powder coated enamel finish 1.5 to 2.5 mil. This coating shall have a non-deductible, unlimited warranty against rust and corrosion for a period of ten years. The color of the coating shall be a "buff" color, matching the generator enclosure.
- C. The transfer switch shall meet or exceed the following standards for emergency standby power system automatic transfer switches:

1. UL 1008

2. NFPA 110
  3. NEC - articles 700 thru 702
  4. NEMA 1 CS-2-447
- D. The automatic transfer switch is to have the following features:
1. Unit to have a bypass switch with rating equal to the automatic transfer switch. The bypass switch shall be a manual type switch.
  2. Suitable for emergency and standby applications on all classes of load.
  3. Adjustable normal source voltage sensing for pickup and dropout. The voltage is to be monitored line to line for all three phases of the switch.
  4. The normal source voltage sensing is to be adjustable from a minimum of 70%-90% of nominal voltage for drop out and a minimum of 75%-100% for pickup.
  5. There shall be a single phase sensing of the emergency source. It shall have an adjustable pickup setting of a minimum of 70% to 100% of nominal voltage.
- E. There shall be time delays activated in the automatic transfer switch as follows:
1. Provide an adjustable time delay to override momentary normal source outages. If the utility provided power does not correct itself to a nominal range of values for voltage and frequency before the time on the relay expires, then all applicable transfer and engine starting signals will be activated. If the power goes back into specification, then no transfer will take place.
    - a. Upon loosing commercial power:
      - 30 seconds for time delay start
      - 2 minutes to neutral transfer
      - 1 minute from neutral to emergency power
    - b. After commercial power is restored:
      - 10 minutes to neutral transfer
      - 1 minute from neutral to utility
  2. Provide an adjustable time delay for transferring the load to emergency power.
  3. Provide an adjustable time delay for retransferring back to the utility power from emergency power.
  4. Provide a non-adjustable (five minute minimum) unloaded running time for cool down of the generator after the power has switched back to the utility supply mode.
  5. Provide a time delay to absorb momentary voltage and frequency spikes or dips during initial genset loading.
- D. The automatic transfer switch shall be a 3-pole switch.
- G. The automatic transfer switch is to have a disconnect switch which will prevent transfer.
- H. The automatic transfer switch shall have in phase transfer control logic which will initiate an in phase transfer of motor loads between line sources. This logic shall help prevent nuisance tripping of distribution circuit breakers and damage to mechanical loads resulting from out of phase power transfer.
- I. The automatic transfer switch is to be designed to be completely front accessible.
- J. The automatic transfer switch is to have true double throw operation. This is accomplished through a single solenoid design which inherently interlocks and prevents contacts from stopping between sources or from being in contact with both sources during any given time period.

- K. The automatic transfer switch shall have a solid neutral connection with full rated terminal lugs for normal, emergency and load.
- L. The automatic transfer switch shall be equipped with a ground stud for the installation of customer provided ground terminations.
- M. The automatic transfer switch shall have, as a minimum, the following equipment for the control panel.
  - 1. Microprocessor based electrical controls with circuitry protected against EMI, voltage transients, ESD, shock vibration, and other hostile environments.
  - 2. Analog or digital kilowatt meter, frequency meter, AC voltmeter and ammeter.
  - 3. Reset switch.
  - 4. Emergency Stop Switch.
  - 5. LCD display, touch key pad, and LED indicators for user access to system information and settings. Provide a green light for when normal source is in operation and red light when generator is operating.
  - 6. Generator set exerciser control.
  - 7. Test pushbutton to simulate a normal power source failure.
  - 8. Provision for optional interface with a P.C.
- N. The automatic transfer switch shall have a surge suppressor which provides protection from transient voltage surges produced by lightning and other sources. The surge suppressors are to be composed of an array of matched metal oxide varistors with sufficient capacity to protect the transfer switch. It is to be connected to the normal power source terminals and installed at the factory.
- O.. The automatic transfer switch electronic components shall be protected from vibration and damage due to rough handling during shipment. If shipped pre-assembled or pre-mounted to the cabinet, ensure adequate connection strength.

## 2.06 SPARE PARTS

- A. The spare parts at each site shall include, but not necessarily be limited to the following:
  - 1. (6) Fuses of each type and size used.
  - 2. (6) Pilot lamps for each type used.
  - 3. (3) Green lens caps for pilot lamps.
  - 4. (3) Red lens caps for pilot lamps.
  - 5. (3) Amber lens caps for pilot lamps.
  - 6. (1) Oil, air and fuel filter.
  - 7. (1) Of each special tool or device, if any, required to maintain the diesel- generator set and included equipment.

## 2.07 FOUNDATION

- A. This concrete foundations for the generator, fuel tank, and transfer switch are to be suitable to fully support, under all load conditions, and with a reasonable safety factor, the complete load. These steel reinforced concrete foundations shall be designed by a professional engineer licensed in the State of Florida. Signed and sealed drawings shall be provided to Manatee County as defined in section 1.06, "Submittals". The top of the concrete foundation shall be a minimum of two inches above the surrounding grade level.



**PART 3 EXECUTION - AT EACH SITE:**

**3.01 INSTALLATION**

- A. The contractor who is awarded the bid, at his expense, shall have all the devices described in this contract delivered to, and unloaded at the site. The contractor shall furnish and install the entire product to include all necessary site preparation, the concrete foundation(s), electrical connections, and all devices described in this contract so that it is fully functional and operable as intended. The installation of the devices shall be per the manufacturer's instructions provided in item 1.06. The contractor, at his expense, shall connect the existing system equipment at each site to the equipment he is providing. The contractor shall insure compatibility with the system he is providing and the existing system. The contractor shall complete the installation of the equipment he provides to the existing site equipment to the degree that it shall not be necessary for the owner (Manatee County) to make further modifications or connections in order to have a fully functional, overall system which is comprised of the existing system and that provided by the contractor under this bid. The owner (Manatee County) shall not be responsible for any costs associated with the complete installation of the product described in these specifications because all associated costs shall be included in the bid price.
- B. The contractor shall install the generator, automatic transfer switch, and conduit as shown on the approved site plan he has prepared for each site.
  - 1. County to provide an existing site plan.
  - 2. Contractor and Lift Station Superintendent shall meet on each site and determine the exact location for the generator, fuel tank and transfer switch.
- C. All wiring shall be installed in schedule 80 PVC conduit sized according to the National Electrical Code for the number and size of conductors contained within. All trenches for underground installation of conduit shall be hand dug.
- D. Install the electrical components per Manatee County Division 16 Electrical Standards as follows:
  - 1. Electrical - General Provisions - 16050-1-5
  - 2. Conduit and Fittings - 16110-1-6
  - 3. Wires and Cables - 16120-1-5

**3.02 FIELD QUALITY CONTROL**

- A. Upon completion of item 3.01, a factory authorized service representative of the product supplied, is to inspect all field assembled and installed components and make any necessary corrections to insure proper equipment operation. Any cost associated with this procedure shall be born by the contractor.

**3.03 TESTING**

- A. All test instruments used to perform the testing are to have been calibrated within the past 12 months. The calibration shall be performed in accordance with the standards of the National Institute for Standards and Technology.
- B. Perform the following on-site tests after items 3.01 and 3.02 have been completed:

1. All necessary tests recommended by the manufacturer
  2. All NFPA 110 tests that are in addition to:
    - System Integrity Test: Verify proper installation, connection, and integrity of each of the components of the diesel generator system before and during operation.
    - Noise level test: Measure and calculate the A-weighted (DbA) levels emanating from the product assembly at five (5) meters for at least six equally spaced points around the enclosure while the machine is under load. Include such points as the exhaust discharge, and cooling air intake and discharge. The noise level test is to be taken at the site after installation and shall adhere to the conditions described in section 2.03A - item 13. Also refer to the test method as defined by ISO 3744.
    - Load Bank test: Run a two hour minimum test with all applicable field load ( See section 1.02 for the ratings of the pump loads at each respective site). The automatic transfer switch is to be engaged and fully tested for all phases of operation during this test. The load bank may be either resistive or inductive. For purposes of the load test, the NEMA LRKVA/HP Code of the pump motors is H.
    - Determine the rise by resistance of the generator while under full load. It may be performed in conjunction with the load test. This test is sometimes called a "Heat Run" or "Hot Shutdown Test" (refer to IEEE - 112) and is performed by measuring the ambient temperature and the resistance across any two phases (+/- 1% accuracy) of the generator immediately prior to starting the machine for the load test and at the conclusion of the load test and temperature stabilization. The test is performed for a minimum of two hours and at least until the measured temperature stabilizes in the machine while under full load. After the termination of the load test and the temperature stabilization, allow the machine to coast to a stop, quickly remove any residual charge on the windings and immediately measure the resistance again (+/- 1% accuracy) across the exact same leads as when measuring the ambient temperature at the beginning of the test. The rise by resistance is calculated by a formula which correlates a change in electrical resistance to a change in temperature.
- C. Compare all measured quantities with required values of testing. Correct all deficiencies identified by tests and repeat test and correction procedure until specified test requirements are met. All problems and shortcomings in the product provided, which are discovered during the testing process, shall be remedied and corrected at the expense of the supplier with no cost to the County.
- D. The County shall have the option of whether or not to witness all testing that is performed. Report all test results in writing to the County.

### 3.04 TRAINING AND DEMONSTRATION

- A. A factory representative of the product is to provide the County's maintenance personnel with a thorough period of instruction and hands-on session regarding the operation, trouble shooting and maintenance of all components of the product. Typical training period: one hour for each site.

### 3.05 DELIVERY

- A. The product described in these specifications shall be fully installed and fully operational, tested and demonstrated within 120 days after the award of the bid has been made.

### 3.06 NOTICE OF DELIVERY, TESTING, TRAINING AND DEMONSTRATION

- A. At least seven business days of notice is to be given by the contractor to the County for delivery, installation, testing, training and demonstration of the product.

### **3.06 COSTS**

- A. The accepted quotation shall be payment in full for all items and services listed in this specification.

**End of Section**

## SECTION 16370 VARIABLE FREQUENCY DRIVES

### PART 1

#### 1.01 SCOPE OF WORK

- A. Furnish two (2) variable frequency drives as specified hereinafter.

#### 1.02 DRIVE APPLICATION

- A. The variable frequency drives will be used to control the speed of inverter duty rated NEMA B design squirrel cage induction motors driving centrifugal pumps in wastewater effluent pumping service. One motor will be rated 150 HP and the other motor will be rated 300 HP.

#### 1.03 DRIVE PARAMETERS

- A. The variable frequency drives shall be designed and sized for the loads intended, shall not exceed their full-rated capacity when the driven pumps are operating at maximum capacity, shall not overload under any operating condition of the pumps, and shall be provided with an integral bypass motor starter package.

#### 1.04 SPARE PARTS

- A. As a minimum, each of the variable frequency drives shall be furnished with the following spare parts:
1. One (1) circuit board of each type used.
  2. Three (3) spare bulbs of each type and size used.
  3. Three (3) lens caps of each color and size used.
  4. Three (3) sets of power fuses.
  5. Three (3) sets of control fuses.

#### 1.05 MANUFACTURER'S QUALIFICATIONS

- A. The variable frequency drives shall be the products of a single manufacturer who has been in the business of designing and manufacturing variable frequency drives for a period of at least ten (10) years.
- B. The manufacturer shall have a factory authorized representative (s) and/or a certified repair shop(s) located within the State of Florida staffed with factory trained service personnel capable of providing installation and start-up assistance, routine and 24-hour emergency repair services (including parts), and training for the Owner's personnel in operating and maintenance procedures associated with the specific variable frequency drives furnished.
- C. The manufacturer shall offer both standard and extended period service contracts as part of his normal operating policy.

#### 1.06 MANUFACTURER'S REPRESENTATIVE

- A. A factory trained authorized representative(s) of the manufacturer shall be available to perform the following functions:
1. Provide installation assistance to the Owner's personnel on an "as needed" basis, one (1) scheduled day minimum.

2. Provide checkout and start-up services as well as conduct the final acceptance tests, two (2) scheduled days.
  3. Provide training for the Owner's personnel in the proper operation and maintenance techniques to be used with the specific AFD's furnished, two (2) scheduled days.
- B. The manufacturer shall include in his bid sufficient funds to cover all the costs (travel, meals, lodging) associated with providing the services listed in Item 1.06.A.1, 2 and 3 above.

## 1.07 SUBMITTALS

- A. Within three (3) weeks of receiving the order, the manufacturer shall furnish the Owner with certified dimension prints which clearly show the nameplate data and outline dimensions.
- B. Prior to start of manufacture of the variable frequency drives, the manufacturer shall submit sets of drawings which shall include, but not necessarily be limited to, enclosure drawings showing the location of both internally and externally mounted components, master wiring diagrams showing all interconnections to the discrete component level, elementary or control schematics including coordination with other external control devices operating in conjunction with the variable frequency drives, and outline drawings with sufficient details to allow for locating conduit stub-ups and field wiring.
- C. Failure to comply with Item 1.06.B above shall be entirely at the manufacturer's risk. Any changes required as a result of the Owner's review will be solely at the manufacturer's expense with no cost to the Owner.

## 1.08 WARRANTY

- A. The manufacturer shall warrant that the variable frequency drives shall be free from defects in all materials and workmanship for a period of two (2) years from date of final acceptance.
- B. During the Warranty period, any and all covered defects shall be corrected by the manufacturer solely at his own expense with no cost to the Owner.

## PART 2 PRODUCTS

### 2.01 VARIABLE FREQUENCY DRIVES

#### A. GENERAL

1. The variable frequency drives shall be the adjustable frequency (AF), variable torque (VT), pulse width modulated (PWM) type designed to provide continuous speed adjustment of 3-phase NEMA B squirrel cage induction motors, inverter duty rated.
2. The adjustable frequency drives (AFD's) shall be designed to control 150 HP and 300 HP motors respectively, and shall be rated for the horsepower (HP), full-load current (Amps), and speed (RPM) of the motors actually supplied.
3. The AFD's shall be furnished in NEMA Type 1 floor-mounted enclosures of the motor control center style. The enclosures shall be forced air ventilated using door-mounted fans. Fan installation shall include cleanable, re-useable air filters.

#### B. CONSTRUCTION

1. The AFD's shall be microprocessor based solid state devices consisting of three (3) basic sections:

- a. A rectifier section to change the constant frequency AC input voltage to a DC voltage. A full wave rectifier shall be used to prevent input line notching. Internal fast acting semiconductor fuses shall be installed to preclude the necessity for having external AC line fuses.
  - b. A DC bus/link section to interconnect the rectifier section and the inverter section. A DC line reactor and capacitors shall be used to smooth the DC bus/link operation, improve displacement power factor, lower harmonic distortion, and eliminate the need for an isolation transformer.
  - c. An inverter section to convert the DC voltage to a variable frequency AC voltage. Insulated gate bipolar transistors (IGBT's) shall be used as output switching devices to allow "tripless" operation, reduce motor noise, provide smoother motor operation, assure reliable and safe shutdowns under fault conditions, and increase drive efficiency; specifically, SCR's, GTO's, and Darlington Transistors are not acceptable as switching devices under this Specification.
2. The AFD's shall be capable of operating from a 3-phase input voltage of 480 Volts  $\pm 10\%$  over a frequency range of 48-63 Hertz while providing a constant volts per Hertz excitation to the motors.
  3. The AFD's shall have a one minute overload rating of 150%; minimum.
  4. The AFD's shall employ surface mount technology for reduced size, high reliability, ease of maintenance, and resistance to vibration.
  5. The AFD's shall incorporate full internal protection against short circuits, ground faults, over- and undervoltage, over- and undercurrent, and temperature extremes.
  6. The AFD's shall contain an adjustable electronic motor overload ( $I^2t$ ) circuit to eliminate the need for an external motor overload relay.
  7. The AFD's shall utilize advanced diagnostic techniques to simplify trouble shooting and correcting problems.
  8. The AFD's shall have a minimum drive efficiency of 97% at full speed and full load.
  9. The AFD's shall have a minimum fundamental power factor of 0.98 at all speeds and loads.
  10. The AFD's shall be able to operate under the following environmental conditions without modification or derating:
    - a. Temperature: 0 to 40EC.
    - b. Altitude: Up to 3,300' above sea level.
    - c. Humidity: 0 to 95%, non-condensing.
  11. The AFD's shall be UL listed and shall comply fully with the applicable standards and provisions of ANSI, NEMA, IEEE, IEC, and NEC, latest revisions.

### C. STANDARD FEATURES

1. The AFD's shall, as a minimum, have the standard features and adjustments listed below:
  - a. The AFD's shall have the same customer interface regardless of horsepower rating, including keypad, digital display, and user connections. The keypad and the digital display shall be accessible without opening the main door of the drive enclosures.
  - b. The keypad shall be the seven (7) button touch type and shall be used for start-up, for setting all parameters, for stepping through the displays and menus, and for local control, including speed adjustments.
  - c. In addition to the keypad speeds adjustment provisions, the AFD's shall also be furnished with a manual speed adjustment potentiometer. The potentiometer shall be accessible without opening the main door of the drive enclosures.
  - d. The digital display shall be the LCD alphanumeric type with 40-character, 2-line capability. The LCD display shall be backlit to provide easy viewing at any angle

- in any light condition. The display shall have adjustable contrast.
- e. The display shall utilize plain English - i.e., all set-up parameters, indications, faults, warnings, and other such information must be displayed in words for easy user understanding; specifically, alphanumeric code numbers requiring memorization, cross-reference tables, or manuals for interpretation will not be acceptable under this Specification.
  - f. The AFD's shall incorporate pre-programmed application macros for ease of start-up. To reduce programming time, the macros shall provide one command operation to reprogram all parameters and user interfaces for a particular application.
  - g. The AFD's shall provide a user selectable option of either displaying a fault or running at a preset speed if a reference input is lost.
  - h. The AFD's shall be capable of a "flying start" into a rotating load and accelerating to setpoint without safety tripping or damage to the drives or driven equipment.
  - i. The user terminal strip shall be isolated from both the line and ground.
  - j. The AFD's shall have the ability to automatically restart after an overcurrent, overvoltage, undervoltage, or loss of input signal protective trip. The number of restart attempts, trial time, and time between reset attempts shall be programmable. If the time between reset attempts is greater than zero, the time remaining until reset occurs shall count down on the display to warn an operator that a restart will occur.
  - k. The AFD's shall be equipped with an automatic extended power loss ride-through circuit which will utilize the inertia of the load to keep the drive powered. Minimum power loss ride-through shall be one-cycle, based on full load and no inertia. Removing power from the motor will not be an acceptable method of increasing power loss ride-through under this Specification.
  - l. The AFD's shall be optimized for a 3 kHz carrier frequency to reduce motor noise.
  - m. The AFD's shall incorporate the following three (3) separate current limit circuits to provide "trip free" operation:
    - 1) A slow current regulation limit circuit which shall be an adjustable percentage of the AFD's variable torque current rating, minimum setting of 125%. This adjustment shall be made via the keypad and shall be displayed in actual amperes, not as a percentage of full load.
    - 2) A rapid current regulation limit circuit which shall be an adjustable percentage of the AFD's variable torque current rating, minimum setting of 170%.
    - 3) A current switch-off limit circuit which shall be a fixed percentage of the AFD's variable torque current rating, minimum setting of 255% instantaneous.
  - n. In addition to any software items listed above, the AFD's shall, as a minimum, contain the following built-in software features:
    - 1) Automatic slip-compensation for maintaining motor speed under varying load conditions.
    - 2) A motor under-load function to protect the pumps.
    - 3) Starting torque up to 180% of full load torque.
    - 4) User selectable manual or automatic IR compensation for torque increases over a selected frequency range.
    - 5) Five (5) adjustable/selectable critical frequency lock-out bands to avoid load resonance points during ramp-up or ramp-down.
    - 6) Two (2) acceleration and two (2) deceleration ramps, adjustable from 0.1 seconds to 1800 seconds.
    - 7) Three (3) adjustable S-curve acceleration and deceleration patterns.

- 8) User selectable linear, squared, or automatic control of the Volts-per-Hertz shape to assure maximum energy efficiency.
- 9) Precise full range frequency resolution adjustable in 0.01 Hertz increments.
- 10) Integral kilowatt-hour and elapsed-time displays.
- 11) Integral PI and sequential control functions.
- 12) Hand-Off-Auto function for local control through the integral keypad and remote control via pushbuttons and/or potentiometers.
- o. The AFD's shall have seven (7) programmable preset speeds as well as unidirectional rotation and coast-to-a-stop features.
- p. The AFD's shall have two (2) programmable analog inputs capable of accepting either a current or a voltage signal. Inputs shall be filtered and shall have adjustable gain and offset.
- q. The AFD's shall have six (6) programmable digital inputs.
- r. The AFD's shall have two (2) programmable analog outputs proportional to the chosen reference (frequency, motor speed, etc.).
- s. The AFD's shall have three (3) programmable digital outputs. Outputs must be true Form C relays; specifically, open collector outputs will not be acceptable under this Specification.
- t. The AFD's shall be equipped with an RS-485 serial port capable of communicating with external PLC's, DCS's, DDC's, and touch-screen graphic operator panels.
- u. The AFD's digital display shall contain, as a minimum, the following information shown in complete English words; specifically, alphanumeric code numbers requiring memorization, cross-reference tables, or manuals for interpretation will not be acceptable under this Specification:

Output Frequency	DC Bus Voltage
Output Voltage	Heatsink Temperature
Motor Speed	Analog Input Values
Motor Current	Keypad Reference Values
Calculated Motor Torque	Elapsed Time
Calculated Motor Power	Kilowatt-hours

- v. The AFD's shall, as a minimum, incorporate the following protective circuits which, in the case of a protective trip, shall stop the drive and announce the fault condition in complete English words; specifically, alphanumeric code numbers requiring memorization, cross-reference tables, or manuals for interpretation will not be acceptable under this Specification:
  - 1) Overcurrent: Trip set at 315% instantaneous (225% RMS) of the AFD's variable torque current rating.
  - 2) Overvoltage: Trip set at 130% of the AFD's rated voltage.
  - 3) Undervoltage: Trip set at 65% of the AFD's rated voltage.
  - 4) Overtemperature: Trip set at +70EC or +85EC dependent upon drive furnished.
  - 5) Ground Fault: Both "running" and "at start".
  - 6) Adaptable Electrical Motor Overload ( $I^2t$ ): Motor protection shall be based on motor speed and load; specifically, circuits which are not speed dependant will not be acceptable under this Specification.
- w. The VFD's shall incorporate a parameter lock feature which will prevent unauthorized personnel from altering the drive parameters without entering a programmable password or combination number. The parameter lock shall also be settable to a digital input.



## D. FACTORY INSTALLED OPTIONS

1. In addition to the Hand-Off-Auto switch and speed potentiometer mentioned hereinabove, the AFD's shall include the following factory installed options:
  - a. Circuit Breaker: The circuit breaker shall be the thermal magnetic, thru-the-door interlock type, padlockable in the Off position.
  - b. 115 VAC Control Transformer and Terminal Board: A terminal board shall be provided for convenient connection of all field control wiring, including all drive inputs and outputs and 115 VAC start input. A control transformer, 150 VA minimum, shall also be included.
  - c. Manual Bypass with Service Switch: A manually operated bypass switch shall allow the motor to be connected directly across the line and operate at full synchronous speed. In bypass, power is to be removed from the drive, but the start signals and the safety interlocks are to remain active. Normal and bypass pilot lights and an external fault circuit with an indicating lamp which illuminates whenever any external safety device has shut down the motor shall be included. Pilot lights shall be the push-to-test type. The service switch shall allow power to be removed from the drive for servicing while the motor operates from line power. The service switch shall be internally mounted to prevent unauthorized personnel from disrupting operation.
  - d. Motor Overload Relay: A standard, manually resettable, bimetallic, motor overload relay with a Class 20 trip curve shall be installed to provide thermal motor protection in the bypass mode. A thru-the-door reset button for the motor overload relay shall also be included.
  - e. Numbered Wires: All internal drive wires shall be numbered at both ends to facilitate maintenance and trouble shooting.

- E. ACCEPTABLE MANUFACTURERS: The AFD's shall be as manufactured by the ABB Industrial Systems Inc., Eaton Corporation (Cutler Hammer Division), Square "D" Company, Allen-Bradley, or Robicon.

## PART 3 EXECUTION

### 3.01 FACTORY TESTING

- A. Prior to assembly in the AFD's, all printed circuit boards shall be thoroughly factory tested and given a minimum eight (8) hour burn-in.
- B. After assembly, the drives shall be given a minimum eight (8) hour load test using a driven motor. The load shall be continuously cycled from no-load to full rated load to induce maximum stress and thermal variations in the drive components.
- C. During the load test, the major drive parameters (input volts, output volts, output current, output speed, output frequency, percent load, etc.) shall be recorded and a copy of the test results shall be reviewed by the Owner prior to the shipment of the AFD's. Similarly, any failure(s) of the drives during the load test shall be recorded, analyzed, corrected, and reported to the Owner before shipment of the AFD's.

### 3.02 SHIPPING

- A. The AFD's shall be so packaged for shipment that they are maximally protected from both physical and environmental damage.

- B. The AFD's shall be transported to the Owner's job sites utilizing the manufacturer's customary method of shipment.

### 3.03 INSTALLATION

- A. The AFD's shall be installed by the Owner's personnel in accordance with the recommendations and procedures set forth in the installation manual furnished by the manufacturer.
- B. An authorized factory trained representative(s) of the manufacturer shall be available to assist the Owner's personnel on an "as needed" basis.

### 3.04 CHECKOUT AND START-UP

- A. Prior to start-up, a factory trained representative(s) of the manufacturer shall be on hand to assure that the AFD's have been properly installed and that all field wiring is correctly terminated.
- B. After checkout, the manufacturer's representative(s) shall then conduct a certified factory start-up using procedures and forms established by the manufacturer of the AFD's.
- C. A copy of the certified start-up form(s) for each drive shall be provided to the Owner, and a copy shall be kept on file by the manufacturer.

### 3.05 FIELD TESTING

- A. After satisfactory completion of the checkout and start-up procedures, the manufacturer's representative(s) shall begin an eight (8) hour acceptance test using actual plant loads.
- B. Any and all short-comings discovered and/or failures occurring during the acceptance test shall be remedied by the manufacturer solely at his own expense with no cost to the Owner.
- C. Any time after four (4) hours of acceptance testing, the Owner may, at his option, curtail further testing and take acceptance of the AFD's.

### 3.06 TRAINING

- A. As set forth in Items 1.05.B and 1.06.A above, a factory trained authorized representative(s) of the manufacturer shall be available at such a time(s) and place(s) established by the owner to train the Owner's personnel in the proper operation and maintenance procedures required by the specific AFD's furnished.

### 3.07 WARRANTY

- A. The manufacturer shall furnish to the Owner a written warranty which complies with the requirements set forth in Item 1.08 above.

END OF SECTION

## SECTION 16450 GROUNDING

### PART 1 GENERAL

#### 1.01 SCOPE OF WORK

- A. Furnish and install a complete grounding system in strict accordance with Article 250 of the National Electrical Code and/or as hereinafter specified and/or as shown on the Contract Drawings.

#### 1.02 SUBMITTALS

- A. The requirements of Section 01340 and Section 16050 shall be met.
- B. Test results as indicated in 3.02 C shall be submitted.

### PART 2 PRODUCTS

#### 2.01 MATERIALS

- A. Ground Rods: The ground rods shall be solid copper or copper-clad steel having a diameter of 5/8-inch and a length of 10-feet. The ground rods shall be as manufactured by Copperweld, or approved equal.
- B. Grounding Conductors
  - 1. All grounding conductors shall be copper. Aluminum or copper-clad aluminum grounding conductors will not be allowed.
  - 2. The grounding conductors shall be sized in accordance with the latest edition of the National Electrical Code, Table 250-94 or Table 250-95, whichever is applicable to the particular grounding conductor.
- C. Ground Rod Clamps: The ground rod clamps shall be malleable iron or cast bronze fittings suitable for use with copper conductors. The ground rod clamps shall be as manufactured by Bridgeport Fittings, Inc.; ITT Blackburn, Inc.; or approved equal.
- E. Dissimilar Metals Junctions: Connections between different metals shall be sealed using NO-OXIDE paint, Grade A, or approved equal.

### PART 3 EXECUTION

#### 3.01 INSTALLATION

- A. Wherever possible, the Contractor shall connect to an existing plant, area or building grounding grid. Where no such grounding grid exists, the Contractor shall provide grounding as hereinafter specified and/or as shown on the Contract Drawings.
- B. Building grounding grid conductors shall be embedded in backfill material around the structures.
- C. All underground conductors shall be laid slack and, where exposed to mechanical injury, shall be protected by pipes or other substantial guards. If guards are iron pipe or other magnetic material, conductors shall be electrically connected to both ends of the guard.

- D. Grounding electrodes shall be driven as required. Where rock is encountered, grounding plates may be used in lieu of grounding rods.
- E. All equipment enclosures, motor and transformer frames, conduit systems, cable armor, exposed structural steel and similar items as required by Article 250 of the NEC shall be grounded.
- F. All steel building columns shall be bonded together and connected to the building ground grid.
- G. Exposed connections shall be made utilizing approved grounding clamps. Buried connections shall be Cadweld, or approved equal, welding process.
- H. The ground bus of service entrance equipment shall be connected to the plant, area or building ground grid, whichever is applicable.
- I. For reasons of mechanical strength, grounding conductors extending from the plant, area or building grounding grid or service entrance ground bus, whichever is applicable, to the ground buses of motor control centers and/or unit substations shall be No. 1/0 AWG bare copper.
- J. Lighting transformer neutrals shall be grounded to the nearest grounding electrode.
- K. Conduits stubbed-up below a motor control center shall be fitted with insulated grounding bushings and connected to the motor control center ground bus. Boxes mounted below motor control centers shall be bonded to the motor control center ground bus. The grounding wire shall be sized in accordance with Table 250-95 of the National Electrical Code, except that a minimum No. 12 AWG shall be used.
- L. Motors shall be grounded in accordance with Section 16150, Item 3.01.A of these Specifications.
- M. The Contractor shall exercise care to insure good ground continuity, in particular between conduits and equipment frames and enclosures. Where necessary, jumper wires shall be installed.

### 3.02 TESTS

- A. The Contractor shall test the ground resistance of the system. The Contractor shall provide all test equipment of which the Owner shall have approval.
- B. The dry season resistance of the system shall not exceed five (5) ohms. If a single driven rod does not produce this value, the Contractor shall drive additional rods and/or take other measures as directed by the Owner without any cost to the Owner.
- C. The Contractor shall furnish to the Owner three (3) copies of the test report certifying that the system is in compliance with the ohmic value requirement. The certified test report shall include, but not necessarily be limited to, the following:
  - 1. Description of the test.
  - 2. Type of test equipment used.
  - 3. Moisture content of the soil.
  - 4. Date and time of the test.
  - 5. Resistance measurement of each rod cluster.
  - 6. Name of individual(s) performing the test.
  - 7. Contractor's certification stamp or seal.

**3.03**

**GUARANTEES AND WARRANTIES**

- A. The Contractor shall guarantee and warrant all materials and labor provided under this Section in accordance with Section 01740 and Section 16050 of these Specifications.

**END OF SECTION**

## SECTION 16921 480 VOLT MOTOR CONTROL CENTER

### PART 1 GENERAL

#### 1.01 SCOPE OF WORK

- A. Furnish, install, test, and place in service motor control center(s) as hereinafter specified and/or shown on the Contract Drawings.
- B. This work will necessarily require interfacing with existing bus ducts; with existing power, control, and instrumentation wiring; with an existing remote telemetry unit (RTU); and with an existing emergency generator. All wiring shall enter and/or exit through the top of the MCC.
- C. The existing MCCs and their associated systems must be maintained in a fully operational condition while the new MCC and its associated power, lighting, control, and instrumentation systems are being installed and tested.
- D. After the new MCC and its associated systems have been installed, tested, and certified ready for operation, the cut-over from the existing MCC and systems to the new MCC and systems shall be done in one continuous uninterrupted period not to exceed twenty-four (24) hours. However, this intended cut-over scenario may be altered at the actual cut-over if Water Treatment Plant operating conditions/requirements mandate that a different cut-over scenario be implemented.
- E. The existing MCC and systems may be removed only after the new MCC and systems are fully operational and have been accepted by the Water Treatment Plant.
- F. The Contractor shall remove from the premises and properly dispose of all items or pieces of equipment not specifically designated for retention by the Water Treatment Plant.

#### 1.02 REGULATORY REQUIREMENTS

- A. MCC-1 shall conform to the latest revisions of the following:
  - Underwriters Laboratory (UL) 845.
  - NEMA ICS-3, Part 1.
  - National Electrical Code, 1996.
- B. The MCC shall be manufactured in an ISO 9001 certified facility.
- C. The MCC, all individual MCC sections, and all individual components shall be UL labeled where applicable.
- D. Since the MCC contains service entrance equipment, it shall be UL labeled ASuitable for Use as Service Equipment.

#### 1.03 MANUFACTURER'S QUALIFICATIONS

- A. The MCC shall be the product of a manufacturer who shall also be the manufacturer of the circuit breakers, motor starters, control and timing relays, and control components (push buttons, etc.).
- B. To match existing equipment and to preclude the unnecessary and expensive duplication of

spare parts, the MCC shall be the Model 6, Class 8998 as manufactured by the Square 'D' Company, no substitutions!

#### 1.04 MANUFACTURER'S REPRESENTATIVE

- A. The manufacturer of the MCC shall provide the services of an authorized factory representative(s) who is well versed in the operation and maintenance of the MCC.
- B. The authorized factory representative shall be available as follows:
  - 1. To assist the Contractor during construction on an as needed basis.
  - 2. To perform the final system check-out, conduct the final acceptance test, and place the MCC into initial service [one (1) day, minimum].
  - 3. To instruct the Owner's personnel in the proper operation and maintenance of the MCC [one (1) day, minimum].

#### 1.05 PACKING, HANDLING, AND SHIPPING

- A. The MCC shall be divided into convenient shipping blocks not to exceed three (3) vertical sections per shipping block.
- B. Each shipping block shall be fitted with a removable lifting angle which will provide a convenient means for attachment to a crane or other suitable lifting equipment. In addition, each shipping block shall be fitted with back and front removable channel sills.
- C. Each shipping block shall be so packed as to prevent damage to the MCC by normal handling methods or by weather elements while in transit.
- D. The manufacturer of the MCC shall deliver it to the appointed receiving site utilizing his customary mode(s) of transportation.

#### 1.06 STORAGE

- A. The MCC shall be stored on-site in a clean, dry, well-ventilated, indoor location which is free from temperature and humidity extremes. Ideally, the temperature range should be 32-degrees F to 104-degrees F and the humidity range should be 15% to 75%, non-condensing.

#### 1.07 SUBMITTALS

- A. Prior to beginning manufacturing of the MCC, the following shall be submitted to the Owner for review and approval:
  - 1. Outline drawings showing major dimensions for the MCC.
  - 2. Front elevation showing compartment and component arrangements for the MCC.
  - 3. Complete master wiring diagrams and elementary or control schematics for the MCC showing the interconnections with existing external devices. Due to the complexity of the interconnections with the existing devices, it is imperative that the diagrams/schematics be carefully prepared. Standard preprinted sheets or drawings marked to indicate applicability to this project will not be acceptable under this Contract.
  - 4. Complete single line diagrams for the MCC showing:
    - a. Incoming line section components.
    - b. Frame and trip rating for all circuit breakers.

- c. Size and type for all motor starters.
  - d. Pertinent data for all special devices such as lighting transformer and panelboard.
  - e. Conduit and conductor sizes for motors and other external loads.
- B. Changes or alternations in the MCC necessitated by the failure to comply with the provisions of Item 1.07.A above will be entirely at the expense of the Contractor and/or manufacturer with no cost accruing to the Owner.

## 1.08 WARRANTY

- A. The MCC shall be warranted to be free from defects in materials and workmanship for a period of one (1) year from date of final acceptance.

## PART 2 PRODUCTS

### 2.01 RATING

- A. The MCC shall be designed for use on a 480 Volt, 3-phase, 4-wire, 60 Hertz power system.
- B. The MCC shall have a power bus system braced for a minimum short circuit capacity of 42,000 Amperes RMS, symmetrical.

### 2.02 CONFIGURATION

- A. The MCC shall consist of individual vertical sections bolted together to form a rigid, free-standing structure.

### 2.03 MATERIAL

- A. The vertical sections shall be fabricated from heavy gauge structural steel, No. 14 gauge minimum thickness, which shall be in full compliance with UL 485.

### 2.04 CONSTRUCTION

#### A. STRUCTURES

1. The MCC structure shall be composed of individual vertical sections of the standard metal-enclosed, free-standing, dead-front type which shall be bolted together to form the MCC assembly.
2. The overall height of the MCC structure shall not exceed 90-inches, exclusive of the removable lifting angle and base channels.
3. The vertical sections shall be 20-inches deep by 20-inches wide, except that the width may be increased as required to allow installation of larger sized devices.
4. The vertical sections shall have 72-inches of vertical space for the installation of control devices. The sections shall also have a 12-inch wireway at the top and a 6-inch wireway at the bottom. The wireways in adjacent sections shall line up to provide wireways the full length of the MCC to accommodate power, control, and instrumentation interconnecting wiring between the various vertical sections.
5. Each 20-inch wide or wider vertical section shall come equipped with all the requisite hardware and bus bars arranged as needed to install modular plug-in units. Each modular plug-in unit shall have its own separate compartment with a door and a disconnecting device. Plug-in units of a similar size and type shall be



interchangeable. All unused space in the vertical section shall be covered by hinged blank doors and shall be equipped to accept the installation of future plug-in units. Each section shall include both top and bottom plates which shall be removable for ease in cutting conduit openings.

6. The compartments shall not only totally isolate the enclosed equipment, but shall also be isolated from each other. The compartments shall be equipped with interlocks to prevent the compartment door from being opened with the disconnecting device in the "Closed" position. An interlock bypass shall be provided for the use of qualified personnel. The disconnecting device shall be able to be locked in the "Off" position, three (3) padlocks minimum. The disconnecting device operating mechanism shall not be attached to the compartment door. Compartment openings to the vertical bus shall be covered by manual shutters.
7. Vertical sections which accept modular plug-in units shall be provided with a 4-inch wide full depth vertical wireway which connects with both the top and the bottom horizontal wireways. The vertical wireways shall be isolated from unit interiors by a full height barrier. The vertical wireways shall have a separate full length hinged door which does not require opening control unit doors for access to the wiring. Vertical sections which house a single, full section control unit shall not be required to have vertical wireways. However, these control units must open directly into the MCC horizontal wireways.
8. The assembled MCC structure shall be a one-deep configuration designed for against-the-wall mounting. All wiring, bus bar joints, and other mechanical parts which require adjustment, servicing, or maintenance must be accessible from either the front or the top of the structures. Rear access will not be acceptable under this Specification.
9. The assembled MCC structure shall meet the requirements for NEMA Type 12 construction. Wiring shall conform to NEMA Class 2, Type C requirements.
10. The MCC shall be painted with a UL recognized acrylic electrodeposition based enamel, ANSI 49 gray. The painting process shall consist of cleaning, rinsings, phosphating, non-chrome sealer rinsings, prepaint rinsings, painting, post-painting rinsings, a baking cure, and a cooling down period. All painted parts must be able to withstand at least 300-hours of salt spraying with less than an 1/8-inch loss of paint from a scribed line per ASTM b117.
11. The MCC shall be furnished as a completely factory assembled unit except where shipping and/or handling requirements make it necessary to subdivide the MCC into smaller more convenient units (see Items 1.05.A, B & C above).

#### B. BUS BARS

1. All bus bars and bus bar connectors shall be silver-plated or tin-plated copper. Aluminum bus bars and aluminum connectors will not be acceptable under this Specification.
2. The main horizontal bus bars shall run the full length of the MCC. Provisions shall be made to allow splicing additional sections onto either end of the MCC.
3. Bus bar ratings shall be based on a 65 degree C maximum temperature rise over a 40 degree C ambient temperature. The main horizontal bus of MCC-1 shall be rated 1600 Amperes. As is required by Item 2.01.B above, the power bus systems shall be braced for a minimum short circuit capacity of 42,000 Amperes RMS, symmetrical.
4. Each vertical section that includes plug-on units shall be equipped with a vertical bus with a minimum rating of 300 A continuous. The vertical bus shall be connected directly to the main horizontal bus without the use of risers or intervening connectors. The vertical buses shall be insulated and isolated with a glass polymer or an equivalent continuous insulation. Taped buses will not be acceptable under this

Specification.

5. The MCC shall be furnished with a 1/4-inch by 2-inch ground bus which runs the full length of the MCC. An appropriately sized mechanical lug shall be provided in the MCC for connecting a ground cable. The ground bus shall be furnished with six (6) drilled holes per vertical section to accept Owner-supplied ground lugs for any loads which require a ground conductor.
6. Each vertical section shall have a vertical ground bus which connects to the main horizontal ground bus. Vertical section construction shall be such that upon insertion of plug-on units, the vertical ground bus shall engage before the power stabs make contact and upon removal of the plug-on units, the power stabs shall disengage before the vertical ground bus is disconnected.

C. WIRING

1. Both intercompartment and intracompartment wiring shall utilize all copper conductors.
2. All terminations and connections shall be via compartment mounted, plug-in terminal blocks which allow compartments to be removed without having to disconnect wires from fixed terminal blocks.
3. Ground conductors shall be green, power conductors shall be black, control conductors shall be red, and conductors energized from sources other than the starter control power transformer shall be yellow.
4. Except for short jumpers, all conductors shall be numbered at both ends and at all intermediate junction points. This numbering scheme shall be reflected in the wiring diagrams.

D. SIGNAGE

1. As is required by Item 1.02.D above and by Article 230-66 of the NEC, the incoming line section of the MCC shall be marked "SUITABLE FOR USE AS SERVICE EQUIPMENT". Sign shall be laminated plastic, white letters on a black or dark gray background.
2. The MCC shall be furnished with a sign marked "DANGER-480 VOLTS". Sign shall be laminated plastic, red letters on a white background. Letters shall be 1-inch high, minimum.
3. All compartments which have voltage sourced from outside the cabinet which are not disconnected by the compartment's motor circuit protector shall be furnished with a sign marked "CAUTION - THIS UNIT CONTAINS A VOLTAGE FROM A SOURCE OUTSIDE OF THIS UNIT". Signs shall be black letters on a high visibility yellow background. Signs shall be 3-inches by 5-inches, minimum size.

2.05 COMPONENTS

A. COMBINATION MOTOR STARTERS

1. All starters shall be the 3-pole, magnetic, combination type suitable for 480 Volt, 60 Hz operation. Starter types (full voltage, non-reversing or reduced voltage) shall be as shown on the Drawings. Reduced voltage starters shall be solid state devices.
2. Starter NEMA sizes shall be determined from the motor horsepowers shown on the Drawings, but in no case shall any starter size be smaller than NEMA 1.
3. Starters shall be provided with a three-pole externally manual reset, overload relay.
4. Unless otherwise indicated on the Drawings, all starters shall be provided with a control transformer. The transformer shall be sized to handle both the contactor load

- and all connected control circuit loads.
5. The control transformer shall have two (2) primary protective fuses and one (1) secondary fuse. The secondary fuse shall be installed in the ungrounded conductor only!
  6. The control transformer rating shall be clearly visible from the front when the starter unit door is opened.
  7. In units where a control transformer is not provided, but where externally powered control circuits are present, the unit disconnect shall include an electrical interlock for disconnection of the externally powered circuits.
  8. Auxiliary control interlocks, field convertible to normally open or normally closed operation, shall be provided where required to assure proper circuit operation.
  9. Unless otherwise indicated on the Drawings, all starter cubicles shall be provided with the following door mounted devices:
    - a. 120 Volt, push-to-test pilot lights:
      - 1) Red "ON" light.
      - 2) Green "OFF" light.
    - b. Three-position selector switch:
      - 1) Hand-Off-Auto.
    - c. Indicating ammeter:
      - 1) Analog type.
    - d. Elapsed time meter:
      - 1) Digital type.
      - 2) Non-resettable.
      - 3) 0-99,999.9 hours.
  10. Where applicable, the door mounted devices shall be the heavy-duty, oiltight type.

#### B. CIRCUIT BREAKERS

1. Circuit breakers shall be the molded case, thermal-magnetic type with an interrupting capacity not less than the design short circuit rating of their respective motor control centers.
2. Incoming line circuit breakers and branch feeder circuit breakers shall have frame and trip ratings as indicated on the Drawings. Circuit breakers used as part of a combination starter shall be the manufacturer's standard for the respective starters furnished.
3. Circuit breaker operating handles shall protrude through, but shall not be attached to, the cubicle door.
4. The circuit breaker handle operating mechanisms shall allow complete ON/OFF control of the circuit breakers with a clear indication of the breaker's status.
5. The handle operators shall also have a separate and distinct TRIPPED position to clearly indicate a circuit breaker trip condition. It shall be possible to reset the tripped circuit breakers without opening the cubicle doors.
6. Provisions shall be made for locking the operating handles in the OFF position, three (3) padlocks minimum.

#### C. INCOMING LINE SECTION

1. The MCC shall be furnished with an incoming line section composed of the following:
  - a. Top mounted main circuit breaker.
  - b. Metering.
  - c. Instrument transformers.
  - d. Surge protection.
2. The main circuit breaker shall comply with all the applicable provisions of Item 2.05.B

- above.
3. The metering for the incoming line section shall consist of the following:
    - a. Voltmeter:
      - 1) Analog, square switchboard type.
      - 2) 250-degree scale.
      - 3) 1% accuracy.
    - b. Voltmeter switch:
      - 1) 7-position for selecting three phases, three phases to ground, and off.
      - 2) Heavy duty, rotary type.
      - 3) Pistol grip handle.
    - c. Ammeter:
      - 1) Analog, square switchboard type.
      - 2) 250-degree scale.
      - 3) 1% accuracy.
    - d. Ammeter switch:
      - 1) 4-position for selecting three phases and off.
      - 2) Heavy duty, rotary type.
      - 3) Pistol grip handle.
    - e. Instrument transformers:
      - 1) Indoor, metering class per ANSI, NEMA, and IEC standards.
      - 2) 600 Volt rating.
      - 3) Butyl-rubber molded.
    - f. Surge protection:
      - 1) Lighting arrestor:
        - (a) Three-phase, MOV type.
      - 2) Surge capacitor:
        - (a) Three-phase type.

#### D. DISTRIBUTION TRANSFORMER

1. MCC-1 shall be furnished with a distribution transformer as follows:
  - a. 10 KVA capacity.
  - b. 480 Volt primary, 120 Volt secondary, single phase, 60 Hertz.
  - c. 150-degree Centigrade temperature rise.
  - d. 30 Ampere primary circuit breaker.

#### E. DISTRIBUTION PANELBOARD

1. MCC-1 only shall be furnished with a distribution panelboard as follows:
  - a. Type: NQOD
  - a. Rating: 120/240 Volt, single phase, three-wire, 60 Hertz.
  - a. Branch breaker type: QOB bolt-on breakers, 1-pole or 2-pole.
  - a. Pole spaces: Twenty (20) total.
  - e. 100 Ampere primary circuit breaker.

#### F. RELAYS

1. Control and/or time delay relays shall be installed in the individual MCC cubicles where necessary for proper operation of the respective circuits.
2. The relays shall be as follows:
  - a. Type:
    - 1) Heavy duty.
    - 2) Machine tool type.

- b. Contacts:
  - 1) Convertible type.
  - 2) 10 Amp (minimum) at 120 Volts.
- c. Timing Units:
  - 1) Pneumatic type.
  - 2) Adjustable, 0-30 minutes.

G. POWER FACTOR CORRECTION CAPACITORS

- 1. One power factor correction capacitor is to be installed for each pump motor. Use 30 KVAR, 480V capacitor for 125 HP motor and 35 KVAR, 480V capacitor for 150 HP motor. Install each capacitor on the load side of the motor magnetic starter.

H. IDENTIFICATION OF DEVICES

- 1. All devices in the MCC, whether internally mounted or through-the-door mounted, shall be identified individually.
- 2. The individual device identification shall be the same designation or number as that used on the respective wiring diagrams.
- 3. The identification of the internally mounted devices shall be by either stenciling thereon or by small nameplates attached thereto.
- 4. The identification of the through-the-door mounted devices shall be by either stenciling or by small nameplates adjacent to the devices on the inside surface of the door.

I. NAMEPLATES

- 1. Engraved nameplates shall be provided for the MCC and each unit compartment.
- 2. The nameplates shall be phenolic or a similar durable plastic material.
- 3. The nameplates shall have a black or dark gray background with white lettering.
- 4. Both the size of the nameplate and the size of the lettering on the nameplate shall be appropriate for the specific application.

2.06 SPARE PARTS

- A. The manufacturer of the MCC shall furnish a list of recommended spare parts for the Owner's review and approval.

- B. The spare parts shall include, but not necessarily be limited to, the following:

- 1. One (1) box of power fuses of each size used.
- 2. One (1) set of starter contacts for each NEMA size used.
- 3. One (1) starter coil for each NEMA size used.
- 4. One (1) box of pilot lamps.
- 5. Six (6) red lens caps for pilot lamps.
- 6. Six (6) green lens caps for pilot lamps.
- 7. Six (6) amber lens caps for pilot lamps.
- 8. One (1) of each special tool or device, if any, required to maintain the MCC and included equipment.

- C. The manufacturer of the MCC shall furnish all items on the spare parts list as approved by the Owner.

## 2.07 FACTORY QUALITY CONTROL

- A. After fabrication, but before shipment, the MCC shall be subjected to a thorough factory quality control inspection.
- B. The quality control inspection shall include, but not necessarily be limited to, the following:
  - 1. Physical inspection of the structures.
  - 2. Physical inspection of both the interior and exterior finished coatings.
  - 3. Physical inspection of the individual components.
  - 4. Physical inspection of the bus installations.
  - 5. Physical inspection of the individual wiring conductors, including terminations.

## 2.08 FACTORY ELECTRICAL TESTING

- A. Prior to shipment, the MCC shall be subjected to a thorough factory electrical testing which shall include, but not necessarily be limited to, the following:
  - 1. AC dielectric test of the power circuit.
  - 2. Power circuit phasing.
  - 3. Control circuit continuity and operation.
  - 4. Polarity and operation of instrument transformers.
  - 5. Polarity and operation of meters and meter switches.
  - 6. Sensitivity and operation of the ground fault system.
  - 7. Operation of the individual devices.

## 2.09 SIGNS AND LABELS

- A. After the MCC has successfully completed both the factory quality control inspection and the factory electrical testing, it shall be affixed with the appropriate signs and labels.
- B. The signs and labels shall include, but not necessarily be limited to, the following:
  - 1. Warning/informational type signs and labels.
  - 2. Operational/instructional type signs and labels.
  - 3. U.L. label (s).
  - 4. Inspector's stamp(s).

## PART 3 EXECUTION

### 3.01 INSTALLATION

- A. EXISTING FACILITIES OPERATION
  - 1. Unless otherwise directed by Water Treatment Plant personnel, the existing facilities (MCC's, bus duct, motors, lighting, etc.) must be kept fully operational during the installation of the new MCC and associated wiring and equipment (see Item 1.02.C above).
  - 2. Temporary shut-down of any of the existing facilities shall only be with the prior approval of and at the convenience of the Water Treatment Plant personnel.
- B. MCC-1

1. The MCC shall be installed on a new steel reinforced concrete pad in the location shown on the Drawings.
2. The bottom mounting members of the MCC shall be bolted to channel sills imbedded in the new concrete pad.
3. The imbedded sills shall run the full length of the two longest sides of the MCC. The sills shall be installed level in all directions.
4. The mounting bolts and associated hardware shall be stainless steel.
5. The MCC shall be maintained in a vertically upright position at all times during installation.
6. The MCC shall be lifted only using the top mounted, factory installed, lifting angles or as otherwise approved, in writing, by the manufacturer of the MCC.
7. The MCC shall be protected against both physical and environmental damage at all times. Any damage to the paint shall be carefully repaired using a touch-up paint furnished by the manufacturer of the MCC.
8. All wiring, whether incoming or outgoing, shall be connected to the MCC via through-the-top conduits with the exception of the main power supplies which shall utilize through-the-top bus duct connections.
9. Field installed interior wiring shall be neatly grouped by circuit and shall be bound by plastic tie-wraps. Care shall be taken to support the wire groupings in such a manner as to avoid any stressing of the termination points.

### 3.02 FIELD TESTS AND CHECKS

- A. After assembly of the MCC, but prior to the termination of any field wiring, the following tests shall be made:
  1. Megger terminals and buses with the main circuit breaker closed and all other circuit breakers open.
  2. Megger terminals and buses with the main circuit breaker and all other circuit breakers closed.
  3. The results of the tests in Items 3.02.A.1 and 3.02.A.2 above shall be forwarded to the Owner for review and approval. The minimum acceptable result for each test is 100 megohms.
  4. The tests in Items 3.02.A.1 and 3.02.A.2 above shall be performed using a 1000 VDC megger after all devices sensitive to the megger voltage have been disconnected.
- B. Before the MCC is energized, check for the following:
  1. All current transformer secondary circuits have been completed and the shunts have been removed.
  2. Correctly sized overloads have been installed for all motors.
  3. All mechanical interlocks operate properly.
- C. After the MCC has been energized, check for the following:
  1. All individual components within the MCC function properly both mechanically and electrically.
  2. There are no visible hot spots on the buses or at major termination points.
- D. After the requirements of Items 3.02.A, B, and C above have been successfully completed, the MCC shall be subjected to the following:
  1. A fully operational 24-hour acceptance test.

2. The acceptance test shall be conducted by an authorized factory representative(s) of the manufacturer of the MCC.
3. The acceptance test shall be witnessed by Water Treatment Plant personnel as designated by the Owner.
4. Anytime during the acceptance test after eight (8) consecutive hours of trouble-free operation, the Owner may, at his option, forego the remainder of the test and accept the MCC at that point. However, this Owner=s option shall in no way relieve the manufacturer=s authorized representative(s) from the obligation to be fully prepared to conduct a complete 24-hour acceptance test.
5. All problems and shortcomings in the MCC and the associated equipment and devices which are discovered during the acceptance test shall be remedied/corrected by the Contractor entirely at his own expense with no cost to the Owner.

END OF SECTION



UTILITY CONSTRUCTION / REHABILITATION  
 POTABLE WATER, RECLAIMED WATER & WASTEWATER

ITEM NO.	DESCRIPTION		U/M	UNIT COST
<b>GROUP A: Site Restoration and Miscellaneous Bid Items.</b>				
1A	Miami Curb Replacement	0-100	LF	\$
		Over 100	LF	\$
2A	Type "A" Curb Replacement	0-100	LF	\$
		Over 100	LF	\$
3A	Type "AB" Curb replacement	0-100	LF	\$
		Over 100	LF	\$
4A	Type "D" Curb Replacement	0-100	LF	\$
		Over 100	LF	\$
5A	Type "F" Curb Replacement	0-100	LF	\$
		Over 100	LF	\$
6A	Asphalt Pavement Restoration (Base & 1 1/2" S-III) (8" min. thick. base)	0-100	SY	\$
		Over 100	SY	\$
7A	Asphalt Pavement Restoration (1 1/2" S-III Overlay)	0-100	SY	\$
		Over 100	SY	\$
8A	Asphalt Pavement Restoration (Mill & Resurface 1 1/2" S-III)	0-100	SY	\$
		Over 100	SY	\$
9A	Concrete Pavement Replacement (8" min. thick.)	0-100	SY	\$
		Over 100	SY	\$
10A	Concrete Sidewalk Replacement (4" min. thick.)	0-100	SY	\$
		Over 100	SY	\$
11A	Driveway Restoration, Concrete (6" min. thick.)	0-100	SY	\$
		Over 100	SY	\$
12A	Driveway Restoration, Asphalt (6" min. thick. base)	0-100	SY	\$
		Over 100	SY	\$
13A	Driveway Restoration, Shell (6" min. thick.)	0-100	SY	\$
		Over 100	SY	\$
14A	Sodding - Bahia	0-500	SY	\$
		Over 500	SY	\$
15A	Sodding - St. Augustine	0-500	SY	\$
		Over 500	SY	\$
16A	Seeding and Mulching	0-500	SY	\$
		Over 500	SY	\$
17A	Furnish & Install Reverse Deadman (pipe diameter)	4 Inch	EA	\$
18A		6 Inch	EA	\$
19A		8 Inch	EA	\$
20A		10 Inch	EA	\$
21A		12 Inch	EA	\$

UTILITY CONSTRUCTION / REHABILITATION  
 POTABLE WATER, RECLAIMED WATER & WASTEWATER

ITEM NO.	DESCRIPTION	U/M	UNIT COST
22A	Grout Fill Abandoned Pipe (Flowable Fill)	CY	\$
23A	Furnish & Install End of Line Blow-Off Assembly	2"	EA \$
24A		4"	EA \$
25A	Furnish & Install Backflow Preventer Assembly	3/4 Inch	EA \$
26A		1 Inch	EA \$
27A		1 1/2 Inch	EA \$
28A		2 Inch	EA \$
29A	Relocate Existing Fire Hydrant Assembly	EA	\$
30A	Adjust Existing Utilities	MH Rim	EA \$
31A		Valve Box	EA \$
32A		Fire Hyd.	EA \$
33A	Cut and Plug Existing Utility Lines (pipe diameter)	2 Inch	EA \$
34A		3 Inch	EA \$
35A		4 Inch	EA \$
36A		6 Inch	EA \$
37A		8 Inch	EA \$
38A		10 Inch	EA \$
39A		12 Inch	EA \$
40A		Remove Out of Service Pipe (pipe diameter)	2 Inch
41A	3 Inch		LF \$
42A	4 Inch		LF \$
43A	6 Inch		LF \$
44A	8 Inch		LF \$
45A	10 Inch		LF \$
46A	12 Inch		LF \$
47A	Rehabilitate Existing Manhole (inside diameter)	4' Dia.	VF \$
48A		5' Dia.	VF \$
49A		6' Dia.	VF \$
50A	Furnish & Install Casing Spacers (carrier pipe diameter)	4 Inch	EA \$
51A		6 Inch	EA \$
52A		8 Inch	EA \$
53A		10 Inch	EA \$
54A		12 Inch	EA \$
55A		14 Inch	EA \$
56A		16 Inch	EA \$
57A		18 Inch	EA \$
58A		20 Inch	EA \$
59A		24 Inch	EA \$
60A	Remove Existing Valve	2 Inch	EA \$
61A		3 Inch	EA \$
62A		4 Inch	EA \$
63A		6 Inch	EA \$
64A		8 Inch	EA \$

UTILITY CONSTRUCTION / REHABILITATION  
 POTABLE WATER, RECLAIMED WATER & WASTEWATER

ITEM NO.	DESCRIPTION		U/M	UNIT COST	
65A		10 Inch	EA	\$	
66A		12 Inch	EA	\$	
67A	Stainless Steel Repair Clamp	4 Inch	EA	\$	
68A		6 Inch	EA	\$	
69A		8 Inch	EA	\$	
70A		10 Inch	EA	\$	
71A		12 Inch	EA	\$	
72A		14 Inch	EA	\$	
73A		16 Inch	EA	\$	
74A		18 Inch	EA	\$	
75A		20 Inch	EA	\$	
76A		24 Inch	EA	\$	
<b>GROUP B: Furnish &amp; Install PVC Pipe</b>					
	Furnish & Install PVC Pipe (C-900)				
1B	4"	To 4' Depth	0-100	LF	\$
			101-500	LF	\$
			Over 500	LF	\$
	4"	4'-8' Depth	0-100	LF	\$
			101-500	LF	\$
			Over 500	LF	\$
	4"	8'-12' Depth	0-100	LF	\$
			101-500	LF	\$
			Over 500	LF	\$
	4"	Over 12' Depth	0-100	LF	\$
			101-500	LF	\$
			Over 500	LF	\$
2B	6"	To 4' Depth	0-100	LF	\$
			101-500	LF	\$
			Over 500	LF	\$
	6"	4'-8' Depth	0-100	LF	\$
			101-500	LF	\$
			Over 500	LF	\$
	6"	8'-12' Depth	0-100	LF	\$
			101-500	LF	\$
			Over 500	LF	\$
	6"	Over 12' Depth	0-100	LF	\$
			101-500	LF	\$
			Over 500	LF	\$

UTILITY CONSTRUCTION / REHABILITATION  
 POTABLE WATER, RECLAIMED WATER & WASTEWATER

ITEM NO.	DESCRIPTION			U/M	UNIT COST
3B	8"	To 4' Depth	0-100	LF	\$
			101-500	LF	\$
			Over 500	LF	\$
	8"	4'-8' Depth	0-100	LF	\$
			101-500	LF	\$
			Over 500	LF	\$
	8"	8'-12' Depth	0-100	LF	\$
			101-500	LF	\$
			Over 500	LF	\$
	8"	Over 12' Depth	0-100	LF	\$
			101-500	LF	\$
			Over 500	LF	\$
4B	10"	To 4' Depth	0-100	LF	\$
			101-500	LF	\$
			Over 500	LF	\$
	10"	4'-8' Depth	0-100	LF	\$
			101-500	LF	\$
			Over 500	LF	\$
	10"	8'-12' Depth	0-100	LF	\$
			101-500	LF	\$
			Over 500	LF	\$
	10"	Over 12' Depth	0-100	LF	\$
			101-500	LF	\$
			Over 500	LF	\$
5B	12"	To 4' Depth	0-100	LF	\$
			101-500	LF	\$
			Over 500	LF	\$
	12"	4'-8' Depth	0-100	LF	\$
			101-500	LF	\$
			Over 500	LF	\$
	12"	8'-12' Depth	0-100	LF	\$
			101-500	LF	\$
			Over 500	LF	\$
	12"	Over 12" Depth	0-100	LF	\$
			101-500	LF	\$
			Over 500	LF	\$
6B	Furnish & Install PVC Pipe (C-905)				
	14"	To 4' Depth	0-100	LF	\$
			101-500	LF	\$
			Over 500	LF	\$
	14"	4'-8' Depth	0-100	LF	\$
			101-500	LF	\$
			Over 500	LF	\$
	14"	8'-12' Depth	0-100	LF	\$
			101-500	LF	\$
			Over 500	LF	\$
	14"	Over 12' Depth	0-100	LF	\$
			101-500	LF	\$
			Over 500	LF	\$

UTILITY CONSTRUCTION / REHABILITATION  
 POTABLE WATER, RECLAIMED WATER & WASTEWATER

ITEM NO.	DESCRIPTION			U/M	UNIT COST
7B	16"	To 4' Depth	0-100	LF	\$
			101-500	LF	\$
			Over 500	LF	\$
	16"	4'-8' Depth	0-100	LF	\$
			101-500	LF	\$
			Over 500	LF	\$
	16"	8'-12' Depth	0-100	LF	\$
			101-500	LF	\$
			Over 500	LF	\$
	16"	Over 12' Depth	0-100	LF	\$
			101-500	LF	\$
			Over 500	LF	\$
8B	18"	To 4' Depth	0-100	LF	\$
			101-500	LF	\$
			Over 500	LF	\$
	18"	4'-8' Depth	0-100	LF	\$
			101-500	LF	\$
			Over 500	LF	\$
	18"	8'-12' Depth	0-100	LF	\$
			101-500	LF	\$
			Over 500	LF	\$
	18"	Over 12' Depth	0-100	LF	\$
			101-500	LF	\$
			Over 500	LF	\$
9B	20"	To 4' Depth	0-100	LF	\$
			101-500	LF	\$
			Over 500	LF	\$
	20"	4'-8' Depth	0-100	LF	\$
			101-500	LF	\$
			Over 500	LF	\$
	20"	8'-12' Depth	0-100	LF	\$
			101-500	LF	\$
			Over 500	LF	\$
	20"	Over 12' Depth	0-100	LF	\$
			101-500	LF	\$
			Over 500	LF	\$
10B	24"	To 4' Depth	0-100	LF	\$
			101-500	LF	\$
			Over 500	LF	\$
	24"	4'-8' Depth	0-100	LF	\$
			101-500	LF	\$
			Over 500	LF	\$
	24"	8'-12' Depth	0-100	LF	\$
			101-500	LF	\$
			Over 500	LF	\$
	24"	Over 12' Depth	0-100	LF	\$
			101-500	LF	\$
			Over 500	LF	\$

UTILITY CONSTRUCTION / REHABILITATION  
 POTABLE WATER, RECLAIMED WATER & WASTEWATER

ITEM NO.	DESCRIPTION			U/M	UNIT COST
11B	30"	To 4' Depth	0-100	LF	\$
			101-500	LF	\$
			Over 500	LF	\$
	30"	4'-8' Depth	0-100	LF	\$
			101-500	LF	\$
			Over 500	LF	\$
	30"	8'-12' Depth	0-100	LF	\$
			101-500	LF	\$
			Over 500	LF	\$
	30"	Over 12' Depth	0-100	LF	\$
			101-500	LF	\$
			Over 500	LF	\$
12B	36"	To 4' Depth	0-100	LF	\$
			101-500	LF	\$
			Over 500	LF	\$
	36"	4'-8' Depth	0-100	LF	\$
			101-500	LF	\$
			Over 500	LF	\$
	36"	8'-12' Depth	0-100	LF	\$
			101-500	LF	\$
			Over 500	LF	\$
	36"	Over 12' Depth	0-100	LF	\$
			101-500	LF	\$
			Over 500	LF	\$
<b>GROUP C: Furnish &amp; Install Ductile Iron Pipe</b>					
1C	Furnish & Install Ductile Iron Pipe (Water Lines)				
	4"	To 4' Depth	0-100	LF	\$
			101-500	LF	\$
			Over 500	LF	\$
	4"	4'-8' Depth	0-100	LF	\$
			101-500	LF	\$
			Over 500	LF	\$
	4"	8'-12' Depth	0-100	LF	\$
			101-500	LF	\$
			Over 500	LF	\$
	4"	Over 12' Depth	0-100	LF	\$
			101-500	LF	\$
Over 500			LF	\$	

UTILITY CONSTRUCTION / REHABILITATION  
 POTABLE WATER, RECLAIMED WATER & WASTEWATER

ITEM NO.	DESCRIPTION			U/M	UNIT COST
2C	6"	To 4' Depth	0-100	LF	\$
			101-500	LF	\$
			Over 500	LF	\$
	6"	4'-8' Depth	0-100	LF	\$
			101-500	LF	\$
			Over 500	LF	\$
	6"	8'-12' Depth	0-100	LF	\$
			101-500	LF	\$
			Over 500	LF	\$
	6"	Over 12' Depth	0-100	LF	\$
			101-500	LF	\$
			Over 500	LF	\$
3C	8"	To 4' Depth	0-100	LF	\$
			101-500	LF	\$
			Over 500	LF	\$
	8"	4'-8' Depth	0-100	LF	\$
			101-500	LF	\$
			Over 500	LF	\$
	8"	8'-12' Depth	0-100	LF	\$
			101-500	LF	\$
			Over 500	LF	\$
	8"	Over 12' Depth	0-100	LF	\$
			101-500	LF	\$
			Over 500	LF	\$
4C	10"	To 4' Depth	0-100	LF	\$
			101-500	LF	\$
			Over 500	LF	\$
	10"	4'-8' Depth	0-100	LF	\$
			101-500	LF	\$
			Over 500	LF	\$
	10"	8'-12' Depth	0-100	LF	\$
			101-500	LF	\$
			Over 500	LF	\$
	10"	Over 12' Depth	0-100	LF	\$
			101-500	LF	\$
			Over 500	LF	\$
5C	12"	To 4' Depth	0-100	LF	\$
			101-500	LF	\$
			Over 500	LF	\$
	12"	4'-8' Depth	0-100	LF	\$
			101-500	LF	\$
			Over 500	LF	\$
	12"	8'-12' Depth	0-100	LF	\$
			101-500	LF	\$
			Over 500	LF	\$
	12"	Over 12' Depth	0-100	LF	\$
			101-500	LF	\$
			Over 500	LF	\$

UTILITY CONSTRUCTION / REHABILITATION  
 POTABLE WATER, RECLAIMED WATER & WASTEWATER

ITEM NO.	DESCRIPTION			U/M	UNIT COST
6C	14"	To 4' Depth	0-100	LF	\$
			101-500	LF	\$
			Over 500	LF	\$
	14"	4'-8' Depth	0-100	LF	\$
			101-500	LF	\$
			Over 500	LF	\$
	14"	8'-12' Depth	0-100	LF	\$
			101-500	LF	\$
			Over 500	LF	\$
	14"	Over 12' Depth	0-100	LF	\$
			101-500	LF	\$
			Over 500	LF	\$
7C	16"	To 4' Depth	0-100	LF	\$
			101-500	LF	\$
			Over 500	LF	\$
	16"	4'-8' Depth	0-100	LF	\$
			101-500	LF	\$
			Over 500	LF	\$
	16"	8'-12' Depth	0-100	LF	\$
			101-500	LF	\$
			Over 500	LF	\$
	16"	Over 12' Depth	0-100	LF	\$
			101-500	LF	\$
			Over 500	LF	\$
8C	18"	To 4' Depth	0-100	LF	\$
			101-500	LF	\$
			Over 500	LF	\$
	18"	4'-8' Depth	0-100	LF	\$
			101-500	LF	\$
			Over 500	LF	\$
	18"	8'-12' Depth	0-100	LF	\$
			101-500	LF	\$
			Over 500	LF	\$
	18"	Over 12' Depth	0-100	LF	\$
			101-500	LF	\$
			Over 500	LF	\$
9C	20"	To 4' Depth	0-100	LF	\$
			101-500	LF	\$
			Over 500	LF	\$
	20"	4'-8' Depth	0-100	LF	\$
			101-500	LF	\$
			Over 500	LF	\$
	20"	8'-12' Depth	0-100	LF	\$
			101-500	LF	\$
			Over 500	LF	\$
	20"	Over 12' Depth	0-100	LF	\$
			101-500	LF	\$
			Over 500	LF	\$



UTILITY CONSTRUCTION / REHABILITATION  
 POTABLE WATER, RECLAIMED WATER & WASTEWATER

ITEM NO.	DESCRIPTION			U/M	UNIT COST
10C	24"	To 4' Depth	0-100	LF	\$
			101-500	LF	\$
			Over 500	LF	\$
	24"	4'-8' Depth	0-100	LF	\$
			101-500	LF	\$
			Over 500	LF	\$
	24"	8'-12' Depth	0-100	LF	\$
			101-500	LF	\$
			Over 500	LF	\$
	24"	Over 12' Depth	0-100	LF	\$
			101-500	LF	\$
			Over 500	LF	\$
11C	30"	To 4' Depth	0-100	LF	\$
			101-500	LF	\$
			Over 500	LF	\$
	30"	4'-8' Depth	0-100	LF	\$
			101-500	LF	\$
			Over 500	LF	\$
	30"	8'-12' Depth	0-100	LF	\$
			101-500	LF	\$
			Over 500	LF	\$
	30"	Over 12' Depth	0-100	LF	\$
			101-500	LF	\$
			Over 500	LF	\$
12C	36"	To 4' Depth	0-100	LF	\$
			101-500	LF	\$
			Over 500	LF	\$
	36"	4'-8' Depth	0-100	LF	\$
			101-500	LF	\$
			Over 500	LF	\$
	36"	8'-12' Depth	0-100	LF	\$
			101-500	LF	\$
			Over 500	LF	\$
	36"	Over 12' Depth	0-100	LF	\$
			101-500	LF	\$
			Over 500	LF	\$
13C	Furnish & Install Ductile Iron Pipe (Sewer Lines)				
	4"	To 4' Depth	0-100	LF	\$
			101-500	LF	\$
			Over 500	LF	\$
	4"	4'-8' Depth	0-100	LF	\$
			101-500	LF	\$
			Over 500	LF	\$
	4"	8'-12' Depth	0-100	LF	\$
			101-500	LF	\$
			Over 500	LF	\$
	4"	Over 12' Depth	0-100	LF	\$
			101-500	LF	\$
Over 500			LF	\$	

UTILITY CONSTRUCTION / REHABILITATION  
 POTABLE WATER, RECLAIMED WATER & WASTEWATER

ITEM NO.	DESCRIPTION			U/M	UNIT COST
14C	6"	To 4' Depth	0-100	LF	\$
			101-500	LF	\$
			Over 500	LF	\$
	6"	4'-8' Depth	0-100	LF	\$
			101-500	LF	\$
			Over 500	LF	\$
	6"	8'-12' Depth	0-100	LF	\$
			101-500	LF	\$
			Over 500	LF	\$
	6"	Over 12' Depth	0-100	LF	\$
			101-500	LF	\$
			Over 500	LF	\$
15C	8"	To 4' Depth	0-100	LF	\$
			101-500	LF	\$
			Over 500	LF	\$
	8"	4'-8' Depth	0-100	LF	\$
			101-500	LF	\$
			Over 500	LF	\$
	8"	8'-12' Depth	0-100	LF	\$
			101-500	LF	\$
			Over 500	LF	\$
	8"	Over 12' Depth	0-100	LF	\$
			101-500	LF	\$
			Over 500	LF	\$
16C	10"	To 4' Depth	0-100	LF	\$
			101-500	LF	\$
			Over 500	LF	\$
	10"	4'-8' Depth	0-100	LF	\$
			101-500	LF	\$
			Over 500	LF	\$
	10"	8'-12' Depth	0-100	LF	\$
			101-500	LF	\$
			Over 500	LF	\$
	10"	Over 12' Depth	0-100	LF	\$
			101-500	LF	\$
			Over 500	LF	\$
17C	12"	To 4' Depth	0-100	LF	\$
			101-500	LF	\$
			Over 500	LF	\$
	12"	4'-8' Depth	0-100	LF	\$
			101-500	LF	\$
			Over 500	LF	\$
	12"	8'-12' Depth	0-100	LF	\$
			101-500	LF	\$
			Over 500	LF	\$
	12"	Over 12' Depth	0-100	LF	\$
			101-500	LF	\$
			Over 500	LF	\$

UTILITY CONSTRUCTION / REHABILITATION  
 POTABLE WATER, RECLAIMED WATER & WASTEWATER

ITEM NO.	DESCRIPTION			U/M	UNIT COST
18C	14"	To 4' Depth	0-100	LF	\$
			101-500	LF	\$
			Over 500	LF	\$
	14"	4'-8' Depth	0-100	LF	\$
			101-500	LF	\$
			Over 500	LF	\$
	14"	8'-12' Depth	0-100	LF	\$
			101-500	LF	\$
			Over 500	LF	\$
	14"	Over 12' Depth	0-100	LF	\$
			101-500	LF	\$
			Over 500	LF	\$
19C	16"	To 4' Depth	0-100	LF	\$
			101-500	LF	\$
			Over 500	LF	\$
	16"	4'-8' Depth	0-100	LF	\$
			101-500	LF	\$
			Over 500	LF	\$
	16"	8'-12' Depth	0-100	LF	\$
			101-500	LF	\$
			Over 500	LF	\$
	16"	Over 12' Depth	0-100	LF	\$
			101-500	LF	\$
			Over 500	LF	\$
20C	18"	To 4' Depth	0-100	LF	\$
			101-500	LF	\$
			Over 500	LF	\$
	18"	4'-8' Depth	0-100	LF	\$
			101-500	LF	\$
			Over 500	LF	\$
	18"	8'-12' Depth	0-100	LF	\$
			101-500	LF	\$
			Over 500	LF	\$
	18"	Over 12' Depth	0-100	LF	\$
			101-500	LF	\$
			Over 500	LF	\$

UTILITY CONSTRUCTION / REHABILITATION  
 POTABLE WATER, RECLAIMED WATER & WASTEWATER

ITEM NO.	DESCRIPTION			U/M	UNIT COST
21C	20"	To 4' Depth	0-100	LF	\$
			101-500	LF	\$
			Over 500	LF	\$
	20"	4'-8' Depth	0-100	LF	\$
			101-500	LF	\$
			Over 500	LF	\$
	20"	8'-12' Depth	0-100	LF	\$
			101-500	LF	\$
			Over 500	LF	\$
	20"	Over 12' Depth	0-100	LF	\$
			101-500	LF	\$
			Over 500	LF	\$
22C	24"	To 4' Depth	0-100	LF	\$
			101-500	LF	\$
			Over 500	LF	\$
	24"	4'-8' Depth	0-100	LF	\$
			101-500	LF	\$
			Over 500	LF	\$
	24"	8'-12' Depth	0-100	LF	\$
			101-500	LF	\$
			Over 500	LF	\$
	24"	Over 12' Depth	0-100	LF	\$
			101-500	LF	\$
			Over 500	LF	\$
23C	30"	To 4' Depth	0-100	LF	\$
			101-500	LF	\$
			Over 500	LF	\$
	30"	4'-8' Depth	0-100	LF	\$
			101-500	LF	\$
			Over 500	LF	\$
	30"	8'-12' Depth	0-100	LF	\$
			101-500	LF	\$
			Over 500	LF	\$
	30"	Over 12' Depth	0-100	LF	\$
			101-500	LF	\$
			Over 500	LF	\$
24C	36"	To 4' Depth	0-100	LF	\$
			101-500	LF	\$
			Over 500	LF	\$
	36"	4'-8' Depth	0-100	LF	\$
			101-500	LF	\$
			Over 500	LF	\$
	36"	8'-12' Depth	0-100	LF	\$
			101-500	LF	\$
			Over 500	LF	\$
	36"	Over 12' Depth	0-100	LF	\$
			101-500	LF	\$
			Over 500	LF	\$

UTILITY CONSTRUCTION / REHABILITATION  
 POTABLE WATER, RECLAIMED WATER & WASTEWATER

ITEM NO.	DESCRIPTION	U/M	UNIT COST
<b>GROUP D: Furnish &amp; Install HDPE Pipe</b>			
1D	2"	0-100	LF \$
		101-500	LF \$
		Over 500	LF \$
2D	4"	0-100	LF \$
		101-500	LF \$
		Over 500	LF \$
3D	6"	0-100	LF \$
		101-500	LF \$
		Over 500	LF \$
4D	8"	0-100	LF \$
		101-500	LF \$
		Over 500	LF \$
5D	10"	0-100	LF \$
		101-500	LF \$
		Over 500	LF \$
6D	12"	0-100	LF \$
		101-500	LF \$
		Over 500	LF \$
7D	14"	0-100	LF \$
		101-500	LF \$
		Over 500	LF \$
8D	16"	0-100	LF \$
		101-500	LF \$
		Over 500	LF \$
9D	18"	0-100	LF \$
		101-500	LF \$
		Over 500	LF \$
10D	20"	0-100	LF \$
		101-500	LF \$
		Over 500	LF \$
11D	24"	0-100	LF \$
		101-500	LF \$
		Over 500	LF \$
12D	30"	0-100	LF \$
		101-500	LF \$
		Over 500	LF \$
13D	36"	0-100	LF \$
		101-500	LF \$
		Over 500	LF \$

UTILITY CONSTRUCTION / REHABILITATION  
 POTABLE WATER, RECLAIMED WATER & WASTEWATER

ITEM NO.	DESCRIPTION	U/M	UNIT COST
<b>GROUP E: Furnish &amp; Install Steel Casing Pipe</b>			
1E	12"	0-100	LF \$
		101-200	LF \$
2E	14"	0-100	LF \$
		101-200	LF \$
3E	16"	0-100	LF \$
		101-200	LF \$
4E	18"	0-100	LF \$
		101-200	LF \$
5E	20"	0-100	LF \$
		101-200	LF \$
6E	24"	0-100	LF \$
		101-200	LF \$
7E	30"	0-100	LF \$
		101-200	LF \$
8E	36"	0-100	LF \$
		101-200	LF \$
9E	42"	0-100	LF \$
		101-200	LF \$
10E	48"	0-100	LF \$
		101-200	LF \$
<b>GROUP F: Furnish &amp; Install PVC Gravity Sewer Pipe</b>			
1F	8" To 6' Depth	0-100	LF \$
		101-500	LF \$
		Over 500	LF \$
	8" 6'-12' Depth	0-100	LF \$
		101-500	LF \$
		Over 500	LF \$
	8" Over 12' Depth	0-100	LF \$
		101-500	LF \$
		Over 500	LF \$
2F	10" To 6' Depth	0-100	LF \$
		101-500	LF \$
		Over 500	LF \$
	10" 6'-12' Depth	0-100	LF \$
		101-500	LF \$
		Over 500	LF \$
	10" Over 12' Depth	0-100	LF \$
		101-500	LF \$
		Over 500	LF \$

UTILITY CONSTRUCTION / REHABILITATION  
 POTABLE WATER, RECLAIMED WATER & WASTEWATER

ITEM NO.	DESCRIPTION			U/M	UNIT COST
3F	12"	To 6' Depth	0-100	LF	\$
			101-500	LF	\$
			Over 500	LF	\$
	12"	6'-12' Depth	0-100	LF	\$
			101-500	LF	\$
			Over 500	LF	\$
	12"	Over 12' Depth	0-100	LF	\$
			101-500	LF	\$
			Over 500	LF	\$
4F	15"	To 6' Depth	0-100	LF	\$
			101-500	LF	\$
			Over 500	LF	\$
	15"	6'-12' Depth	0-100	LF	\$
			101-500	LF	\$
			Over 500	LF	\$
	15"	Over 12' Depth	0-100	LF	\$
			101-500	LF	\$
			Over 500	LF	\$
5F	18"	To 6' Depth	0-100	LF	\$
			101-500	LF	\$
			Over 500	LF	\$
	18"	6'-12' Depth	0-100	LF	\$
			101-500	LF	\$
			Over 500	LF	\$
	18"	Over 12' Depth	0-100	LF	\$
			101-500	LF	\$
			Over 500	LF	\$
6F	21"	To 6' Depth	0-100	LF	\$
			101-500	LF	\$
			Over 500	LF	\$
	21"	6'-12' Depth	0-100	LF	\$
			101-500	LF	\$
			Over 500	LF	\$
	21"	Over 12' Depth	0-100	LF	\$
			101-500	LF	\$
			Over 500	LF	\$
7F	24"	To 6' Depth	0-100	LF	\$
			101-500	LF	\$
			Over 500	LF	\$
	24'	6'-12' Depth	0-100	LF	\$
			101-500	LF	\$
			Over 500	LF	\$
	24"	Over 12' Depth	0-100	LF	\$
			101-500	LF	\$
			Over 500	LF	\$

UTILITY CONSTRUCTION / REHABILITATION  
 POTABLE WATER, RECLAIMED WATER & WASTEWATER

ITEM NO.	DESCRIPTION	U/M	UNIT COST
8F	30" To 6' Depth	0-100	LF \$
		101-500	LF \$
		Over 500	LF \$
	30" 6'-12' Depth	0-100	LF \$
		101-500	LF \$
		Over 500	LF \$
	30" Over 12' Depth	0-100	LF \$
		101-500	LF \$
		Over 500	LF \$
9F	36" To 6' Depth	0-100	LF \$
		101-500	LF \$
		Over 500	LF \$
	36" 6'-12' Depth	0-100	LF \$
		101-500	LF \$
		Over 500	LF \$
	36" Over 12' Depth	0-100	LF \$
		101-500	LF \$
		Over 500	LF \$
<b>GROUP G: Furnish &amp; Install Sanitary Sewer Service</b>			
1G	8"x6" PVC Sewer Wye and 25 LF PVC Sewer Service Lateral with clean-out laid to grade. To 6' Depth		
		EA	\$
		Additional Lateral Footage over 25'	LF \$
		6'-12' Depth	EA \$
		Additional Lateral Footage over 25'	LF \$
		Over 12' Depth	EA \$
2G	10"x6" PVC Sewer Wye and 25 LF PVC Sewer Service Lateral with clean-out laid to grade. To 6' Depth		
		EA	\$
		Additional Lateral Footage over 25'	LF \$
		6'-12' Depth	EA \$
		Additional Lateral Footage over 25'	LF \$
		Over 12' Depth	EA \$
3G	12"x6" PVC Sewer Wye and 25 LF PVC Sewer Service Lateral with clean-out laid to grade. To 6' Depth		
		EA	\$
		Additional Lateral Footage over 25'	LF \$
		6'-12' Depth	EA \$
		Additional Lateral Footage over 25'	LF \$
		Over 12' Depth	EA \$
	Additional Lateral Footage over 25'	LF \$	



**UTILITY CONSTRUCTION / REHABILITATION  
POTABLE WATER, RECLAIMED WATER & WASTEWATER**

ITEM NO.	DESCRIPTION	U/M	UNIT COST
<b>GROUP H: Furnish &amp; Install Water Services</b>			
1H	1" PE Single Service (Short) with 10 LF Service Pipe	EA	\$
2H	1" PE Single Service (Long) with 25 LF Service Pipe	EA	\$
	Additional 1" Service Pipe over 10' (Short) and 25' (Long)	LF	\$
3H	1 1/2" PE Double or Triple Service (Short) with 10 LF Service Pipe	EA	\$
4H	1 1/2" PE Double or Triple Service (Long) with 25 LF Service Pipe	EA	\$
	Additional 1 1/2" Service Pipe over 10' (Short) and 25' (Long)	LF	\$
5H	2" PE Quadruple Service (Short) with 10 LF Service Pipe	EA	\$
6H	2" PE Quadruple Service (Long) with 25 LF Service Pipe	EA	\$
	Additional 2" Service Pipe over 10' (Short) and 25' (Long)	LF	\$
<b>GROUP I: Furnish &amp; Install Meter Box</b>			
1I	Meter Box - Potable Water	EA	\$
2I	Meter Box - Reclaimed Water	EA	\$
<b>GROUP J: Furnish &amp; Install Core Bore Manhole</b>			
1J	Core Bore Manhole (carrier pipe diameter)	2 Inch	EA \$
2J		4 Inch	EA \$
3J		6 Inch	EA \$
4J		8 Inch	EA \$
5J		10 Inch	EA \$
6J		12 Inch	EA \$
7J		14 Inch	EA \$
8J		16 Inch	EA \$
9J		18 Inch	EA \$
10J		20 Inch	EA \$
11J		24 Inch	EA \$
<b>GROUP K: Furnish &amp; Install Precast Concrete Manhole</b>			
1K	4' Diameter Manhole without Liner (per vertical foot)	0'-6'	VF \$
		6'-12'	VF \$
		Over 12'	VF \$
2K	5' Diameter Manhole without Liner (per vertical foot)	0'-6'	VF \$
		6'-12'	VF \$
		Over 12'	VF \$
3K	6' Diameter Manhole without Liner (per vertical foot)	0'-6'	VF \$
		6'-12'	VF \$
		Over 12'	VF \$
4K	4' Diameter Manhole with Liner (per vertical foot)	0'-6'	VF \$
		6'-12'	VF \$
		Over 12'	VF \$
5K	5' Diameter Manhole with Liner (per vertical foot)	0'-6'	VF \$
		6'-12'	VF \$
		Over 12'	VF \$
6K	6' Diameter Manhole with Liner (per vertical foot)	0'-6'	VF \$
		6'-12'	VF \$
		Over 12'	VF \$
<b>GROUP L: Furnish &amp; Install Fittings</b>			
1L	Ductile Iron	LB	\$
2L	PVC	LB	\$
3L	HDPE	LB	\$

UTILITY CONSTRUCTION / REHABILITATION  
 POTABLE WATER, RECLAIMED WATER & WASTEWATER

ITEM NO.	DESCRIPTION	U/M	UNIT COST
<b>GROUP M: Furnish &amp; Install Pipe Joint Restraints</b>			
1M	Pipe Joint Restraints	2 Inch	EA \$
2M		4 Inch	EA \$
3M		6 Inch	EA \$
4M		8 Inch	EA \$
5M		10 Inch	EA \$
6M		12 Inch	EA \$
7M		14 Inch	EA \$
8M		16 Inch	EA \$
9M		18 Inch	EA \$
10M		20 Inch	EA \$
11M		24 Inch	EA \$
12M		30 Inch	EA \$
13M		36 Inch	EA \$
<b>GROUP N: Furnish &amp; Install Pipe Adapters</b>			
1N	Pipe Adapters	2 Inch	EA \$
2N		4 Inch	EA \$
3N		6 Inch	EA \$
4N		8 Inch	EA \$
5N		10 Inch	EA \$
6N		12 Inch	EA \$
7N		14 Inch	EA \$
8N		16 Inch	EA \$
9N		18 Inch	EA \$
10N		20 Inch	EA \$
11N		24 Inch	EA \$
12N		30 Inch	EA \$
13N		36 Inch	EA \$
<b>GROUP O: Furnish &amp; Install Gate Valve</b>			
1O	Gate Valve	2 Inch	EA \$
2O		3 Inch	EA \$
3O		4 Inch	EA \$
4O		6 Inch	EA \$
5O		8 Inch	EA \$
6O		10 Inch	EA \$
7O		12 Inch	EA \$
8O		14 Inch	EA \$
9O		16 Inch	EA \$
10O		18 Inch	EA \$
11O		20 Inch	EA \$
12O		24 Inch	EA \$
<b>GROUP P: Furnish &amp; Install Butterfly Valve</b>			
1P	Butterfly Valve	16 Inch	EA \$
2P		18 Inch	EA \$
3P		20 Inch	EA \$
4P		24 Inch	EA \$
5P		30 Inch	EA \$
6P		36 Inch	EA \$

UTILITY CONSTRUCTION / REHABILITATION  
 POTABLE WATER, RECLAIMED WATER & WASTEWATER

ITEM NO.	DESCRIPTION	U/M	UNIT COST
<b>GROUP Q: Furnish &amp; Install Plug Valve</b>			
1Q	Plug Valve	3 Inch	EA \$
2Q		4 Inch	EA \$
3Q		6 Inch	EA \$
4Q		8 Inch	EA \$
5Q		10 Inch	EA \$
6Q		12 Inch	EA \$
7Q		14 Inch	EA \$
8Q		16 Inch	EA \$
9Q		18 Inch	EA \$
10Q		20 Inch	EA \$
11Q		24 Inch	EA \$
<b>GROUP R: Furnish &amp; Install Air Release Valve</b>			
1R	Air release valve	1 Inch	EA \$
2R		2 Inch	EA \$
<b>GROUP S: Furnish &amp; Install Stainless Steel Cabinet (for above ground air release valves).</b>			
1S	Stainless Steel Cabinet	EA	\$
<b>GROUP T: Furnish &amp; Install Fire Hydrant Assembly</b>			
1T	Fire Hydrant Assembly	EA	\$
<b>GROUP U: Furnish &amp; Install Tapping Sleeve</b>			
1U	Tapping Sleeve (Main x Outlet)	6 x 4	EA \$
2U		8 x 4	EA \$
3U		8 x 6	EA \$
4U		10 x 4	EA \$
5U		10 x 6	EA \$
6U		10 x 8	EA \$
7U		12 x 4	EA \$
8U		12 x 6	EA \$
9U		12 x 8	EA \$
10U		12 x 10	EA \$
11U		16 x 4	EA \$
12U		16 x 6	EA \$
13U		16 x 8	EA \$
14U		16 x 10	EA \$
15U		16 x 12	EA \$
16U		18 x 4	EA \$
17U		18 x 6	EA \$
18U		18 x 8	EA \$
19U		18 x 10	EA \$
20U		18 x 12	EA \$
21U		20 x 4	EA \$
22U		20 x 6	EA \$
23U		20 x 8	EA \$
24U		20 x 10	EA \$
25U		20 x 12	EA \$
26U		24 x 4	EA \$
27U		24 x 6	EA \$
28U		24 x 8	EA \$
29U		24 x 10	EA \$
30U		24 x 12	EA \$

UTILITY CONSTRUCTION / REHABILITATION  
 POTABLE WATER, RECLAIMED WATER & WASTEWATER

ITEM NO.	DESCRIPTION		U/M	UNIT COST
<b>GROUP V: Furnish &amp; Install Tapping Valve</b>				
1V	Tapping Valve	4 Inch	EA	\$
2V		6 Inch	EA	\$
3V		8 Inch	EA	\$
4V		10 Inch	EA	\$
5V		12 Inch	EA	\$
<b>GROUP W: Furnish &amp; Install Valve (Cut-In)</b>				
1W	Gate Valve (Cut-In)	2 Inch	EA	\$
2W		3 Inch	EA	\$
3W		4 Inch	EA	\$
4W		6 Inch	EA	\$
5W		8 Inch	EA	\$
6W		10 Inch	EA	\$
7W		12 Inch	EA	\$
8W	Plug Valve (Cut-In)	3 Inch	EA	\$
9W		4 Inch	EA	\$
10W		6 Inch	EA	\$
11W		8 Inch	EA	\$
12W		10 Inch	EA	\$
13W		12 Inch	EA	\$
14W		16 Inch	EA	\$
15W		18 Inch	EA	\$
16W		20 Inch	EA	\$
17W		24 Inch	EA	\$
18W	Butterfly Valve (Cut-In)	16 Inch	EA	\$
19W		18 Inch	EA	\$
20W		20 Inch	EA	\$
21W		24 Inch	EA	\$
22W		30 Inch	EA	\$
23W		36 Inch	EA	\$
<b>GROUP X: Furnish &amp; Install Materials to Rehabilitate Lift Stations</b>				
1X	Wetwell Piping - Remove and replace with Sch. 80 PVC wetwell piping from the pump base ell or flanged eccentric reducer to the check valve in the valve vault. Manatee County personnel will remove and reinstall pumps.	4 Inch	LF	\$
2X		6 Inch	LF	\$
3X		8 Inch	LF	\$
4X	Wetwell Piping - Remove and replace with HDPE wetwell piping from the pump base ell or flanged eccentric reducer to the check valve in the valve vault. Manatee County personnel will remove and reinstall pumps.	4 Inch	LF	\$
5X		6 Inch	LF	\$
6X		8 Inch	LF	\$
7X	Wetwell Piping - Remove and replace with S.S. wetwell piping from the pump base ell or flanged eccentric reducer to the check valve in the valve vault. Manatee County personnel will remove and reinstall pumps.	4 Inch	LF	\$
8X		6 Inch	LF	\$
9X		8 Inch	LF	\$
10X		10 Inch	LF	\$
11X		12 Inch	LF	\$

**UTILITY CONSTRUCTION / REHABILITATION  
POTABLE WATER, RECLAIMED WATER & WASTEWATER**

ITEM NO.	DESCRIPTION	U/M	UNIT COST
12X	Remove and replace pump base ells. This will include installation of new Hilti HSL series anchors or approved equal. The replacement pump base ells shall be BPIU series as manufactured by Barney's Pumps, Inc. or approved equal.	4" BPIU-14	EA \$
13X		6" BPIU-16	EA \$
14X		8" BPIU-18	EA \$
15X	Remove and replace existing pipe bracing with S.S. pipe bracing - Duplex Wetwell	6' Dia.	EA \$
16X		8' Dia.	EA \$
17X		10' Dia.	EA \$
18X		12' Dia.	EA \$
19X	Remove and replace existing pipe bracing with S.S. pipe bracing - Triplex Wetwell	8' Dia.	EA \$
20X		10' Dia.	EA \$
21X		12' Dia.	EA \$
22X	Furnish & Install 6 Inch PVC stilling well inside wetwell. (for level transducer)	LF	\$
23X	Raise existing wetwell top elevation, per vertical foot.	6' Dia.	VF \$
24X	This includes removing existing wetwell top slab, raising wetwell walls with new reinforced concrete section (4,000 psi), reinstalling existing wetwell top slab or installing a new wetwell top slab. (New wetwell top slab paid under separate bid item)	8' Dia.	VF \$
25X		10' Dia.	VF \$
26X		12' Dia.	VF \$
27X	Replace existing wetwell top slab with new wetwell top slab (4,000 psi with reinforcement). The top slab shall be 10" thick and installed with one or more aluminum hatch covers. (Hatch covers paid under separate bid item)	6' Dia.	EA \$
28X		8' Dia.	EA \$
29X		10' Dia.	EA \$
30X		12' Dia.	EA \$
31X	Furnish & Install aluminum hatch cover.	30"x36" Single Door	EA \$
32X		30"x48" Single Door	EA \$
33X		36"x48" Single Door	EA \$
34X		36"x48" Double Door	EA \$
35X		36"x60" Double Door	EA \$
36X		48"x48" Double Door	EA \$
37X		48"x72" Double Door	EA \$
38X	Remove and replace 2 Inch S.S. pump guide rail system	LF	\$
39X	Reinstall used 2 Inch S.S. pump guide rails	SET	\$
40X	Remove and dispose existing concrete wetwell fillet	CY	\$
41X	Furnish & Install new concrete wetwell fillet (3,000 psi, Type II, no reinf.)	CY	\$
42X	Furnish & Install new concrete wetwell bottom (4,000 psi, Type II, with reinf.)	CY	\$
43X	Furnish & Install resilient seals @ pipe thru concrete walls. (carrier pipe diameter)	4 Inch	EA \$
44X		6 Inch	EA \$
45X		8 Inch	EA \$
46X		10 Inch	EA \$
47X		12 Inch	EA \$
48X	Furnish & Install wetwell liner and/or coating system. Includes cleaning and surface preparation. (T-Lock liner removal paid under separate bid item)	Protective Liner System	SF \$
49X		Aquatapoxy 405	SF \$
50X		Spraywall Urethane	SF \$
51X		Ceilcote 68HT Lining	SF \$

**UTILITY CONSTRUCTION / REHABILITATION  
POTABLE WATER, RECLAIMED WATER & WASTEWATER**

ITEM NO.	DESCRIPTION	U/M	UNIT COST	
52X	T-Lock liner removal and disposal	SF	\$	
53X	Furnish & Install PVC drain with p-trap from valve vault to wetwell including re-grouting valve vault floor to drain.	2 Inch	EA \$	
54X		3 Inch	EA \$	
55X	Furnish & Install Flanged Gate Valve	4 Inch	EA \$	
56X		6 Inch	EA \$	
57X		8 Inch	EA \$	
58X		10 Inch	EA \$	
59X		12 Inch	EA \$	
60X		Furnish & Install Flanged Check Valve	4 Inch	EA \$
61X	6 Inch		EA \$	
62X	8 Inch		EA \$	
63X	10 Inch		EA \$	
64X	12 Inch		EA \$	
65X	Furnish & Install Flanged Ductile Iron Pipe	4 Inch	LF \$	
66X		6 Inch	LF \$	
67X		8 Inch	LF \$	
68X		10 Inch	LF \$	
69X		12 Inch	LF \$	
70X	Furnish & Install Flanged Ductile Iron Fittings	LB	\$	
71X	Furnish & Install Flange Adapters	4 Inch	EA \$	
72X		6 Inch	EA \$	
73X		8 Inch	EA \$	
74X		10 Inch	EA \$	
75X		12 Inch	EA \$	
76X	Furnish & Install Male Quick Coupler Adapter	4 Inch	EA \$	
77X		6 Inch	EA \$	
78X	Furnish & Install adjustable S.S. pipe supports in valve vault.	EA	\$	
79X	Furnish & Install precast concrete doghouse vault over existing force main. Includes a 6" reinforced concrete top and bottom and 30"x36" aluminum hatch cover. (The vault shall be watertight) (Hatch cover paid under separate bid item) (Payment will be per vertical foot with a maximum height of 8 feet)	4' x 4'	VF \$	
80X		Furnish & Install precast concrete valve vault with top, bottom and aluminum hatch cover. (Hatch cover paid under separate bid item)	5' x 5' x 5'	EA \$
81X			6' x 6' x 6'	EA \$
82X		Furnish & Install Influent Line Plug	6 Inch	EA \$
83X	8 Inch		EA \$	
84X	10 Inch		EA \$	
85X	12 Inch		EA \$	
86X	18 Inch		EA \$	
87X	24 Inch		EA \$	
88X		30 Inch	EA \$	
89X	By-Pass Pumping System which includes all necessary piping.	Max flow to 500 GPM, Max Head to 275 Ft	DAY \$	
90X		Max flow to 1000 GPM, Max Head to 150 Ft	DAY \$	
91X	Pumps to be dry prime and sound attenuated to max. of 70db at 25'	Max flow to 2400 GPM, Max Head to 175 Ft	DAY \$	
92X		Max flow to 6500 GPM, Max Head to 275 Ft	DAY \$	
93X	Furnish & Install 3/4 Inch water service	LF	\$	
94X	Furnish & Install 3/4 Inch hose bib assembly	EA	\$	
95X	Furnish & Install 3/4 Inch meter and backflow preventer assembly	EA	\$	
96X	Furnish & Install 20" X 30" X 1.25" steel base plate with four 1" anchor bolt holes	EA	\$	
	four 3/4" threaded base ell mounting bolt holes, and two 1/2" threaded eyebolt holes			

UTILITY CONSTRUCTION / REHABILITATION  
 POTABLE WATER, RECLAIMED WATER & WASTEWATER

ITEM NO.	DESCRIPTION	U/M	UNIT COST
<b>GROUP Y: Furnish &amp; Install Electrical Components to Rehabilitate Lift Stations</b>			
1Y	Remove and replace electric meter can. Includes all connections and installation of meter.	EA	\$
2Y	Remove and replace fused safety switch.	G.E. TH4323SS	EA \$
3Y	Includes all connections and lightning arrestor mounted on exterior of safety switch.	G.E. TH4324SS	EA \$
4Y	Remove and replace control panel.	Duplex, 100 Amps., 230 Volt, 1 Phase, size 1 starters	EA \$
5Y		Duplex, 100 Amps., 230 Volt, 1 Phase, size 2 starters	EA \$
6Y	Includes conduit and wire connections to the safety switch,	Duplex, 100 Amps., 230 Volt, 3 Phase, size 1 starters	EA \$
7Y		Duplex, 100 Amps., 230 Volt, 3 Phase, size 2 starters	EA \$
8Y	all wire connections to the wetwell,	Duplex, 200 Amps., 230 Volt, 3 Phase, size 2 starters	EA \$
9Y	reconnecting all ground wiring,	Duplex, 200 Amps., 230 Volt, 3 Phase, size 3 starters	EA \$
10Y	connecting wiring from antenna tower, and	Triplex, 200 Amps., 230 Volt, 3 Phase, size 2 starters	EA \$
11Y	all conduit and wire connections to the flow meter vault.	Triplex, 200 Amps., 230 Volt, 3 Phase, size 3 starters	EA \$
12Y		Duplex, 100 Amps., 460 Volt, 3 Phase, size 2 starters	EA \$
13Y		Duplex, 200 Amps., 460 Volt, 3 Phase, size 2 starters	EA \$
14Y		Duplex, 200 Amps., 460 Volt, 3 Phase, size 3 starters	EA \$
15Y		Duplex, 200 Amps., 460 Volt, 3 Phase, size 4 starters	EA \$
16Y		Triplex, 200 Amps., 460 Volt, 3 Phase, size 2 starters	EA \$
17Y		Triplex, 200 Amps., 460 Volt, 3 Phase, size 3 starters	EA \$
18Y		Triplex, 200 Amps., 460 Volt, 3 Phase, size 4 starters	EA \$
19Y	Remove and replace conduit from control panel to wetwell. Includes connections to panel and sealing inside wetwell wall.	2 Inch Schedule 80 PVC	LF \$
20Y		3 Inch Schedule 80 PVC	LF \$
21Y		4 Inch Schedule 80 PVC	LF \$
22Y	Remove and replace electrical service from power source to electric meter. Includes wire, conduit, permits, and connection to power source and meter can.	100 Amps. at 230 Volts	LF \$
23Y		200 Amps. at 230 Volts	LF \$
24Y		100 Amps. at 460 Volts	LF \$
25Y		200 Amps. at 460 Volts	LF \$
26Y	Remove and replace electrical mounting structure. Includes 3" vertical pipes, horizontal 1-5/8" unistrut and all hardware required to mount the panel, safety switch and meter.		EA \$
27Y	Furnish & Install site light on antenna mast.		EA \$
28Y	Furnish & Install an on-site diesel powered generator and automatic power transfer switch with a single weather protected enclosure and concrete pad. Includes all permits, wire, conduit, and connections required to provide a complete working system.	35 KW	EA \$
29Y		60 KW	EA \$
30Y		125 KW	EA \$
31Y	Also includes testing, system start-up, manuals and training. Generator to be 230V or 460V as required for the sizes listed.	150 KW	EA \$
32Y	Furnish & Install float switches		EA \$
33Y	Furnish & Install Senex model GSX3-PP100-A49-B49-XX-CO1-D49 transducer or approved equal.		EA \$
34Y	Furnish & Install GE Panametrics, Model AT868 Aqua Trans flow meter, or approved equal. Includes above ground transmitter, all wiring, conduit and analog monitor for connection to telemetry.		EA \$
35Y	Furnish & Install force main pressure transducer. Includes tapping saddle and valve, stainless steel diaphragm seal, Ashcroft model K1-7-M02-42-F2-100 transducer or approved equal, wiring and 1 Inch PVC conduit.		EA \$

UTILITY CONSTRUCTION / REHABILITATION  
 POTABLE WATER, RECLAIMED WATER & WASTEWATER

ITEM NO.	DESCRIPTION	U/M	UNIT COST
<b>GROUP Z: Pipe Pigging &amp; Cleaning</b>			
1Z	Preparatcion of work plan and mobilization for all sizes	EA	
2Z	12"	0-500	LF \$
		500 +	LF \$
3Z	14"	0-500	LF \$
		500 +	LF \$
4Z	16"	0-500	LF \$
		500 +	LF \$
5Z	18"	0-500	LF \$
		500 +	LF \$
6Z	20"	0-500	LF \$
		500 +	LF \$
7Z	24"	0-500	LF \$
		500 +	LF \$
8Z	30"	0-500	LF \$
		500 +	LF \$
9Z	36"	0-500	LF \$
		500 +	LF \$
10Z	42"	0-500	LF \$
		500 +	LF \$
11Z	48"	0-500	LF \$
		500 +	LF \$



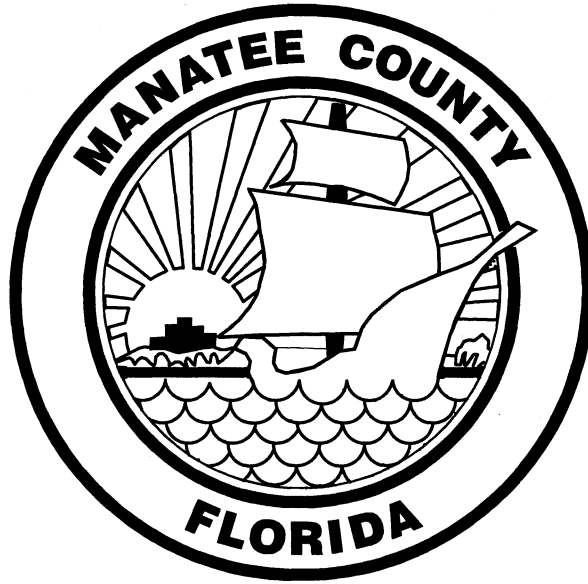

# MANATEE COUNTY PROJECT MANAGEMENT UTILITY STANDARDS

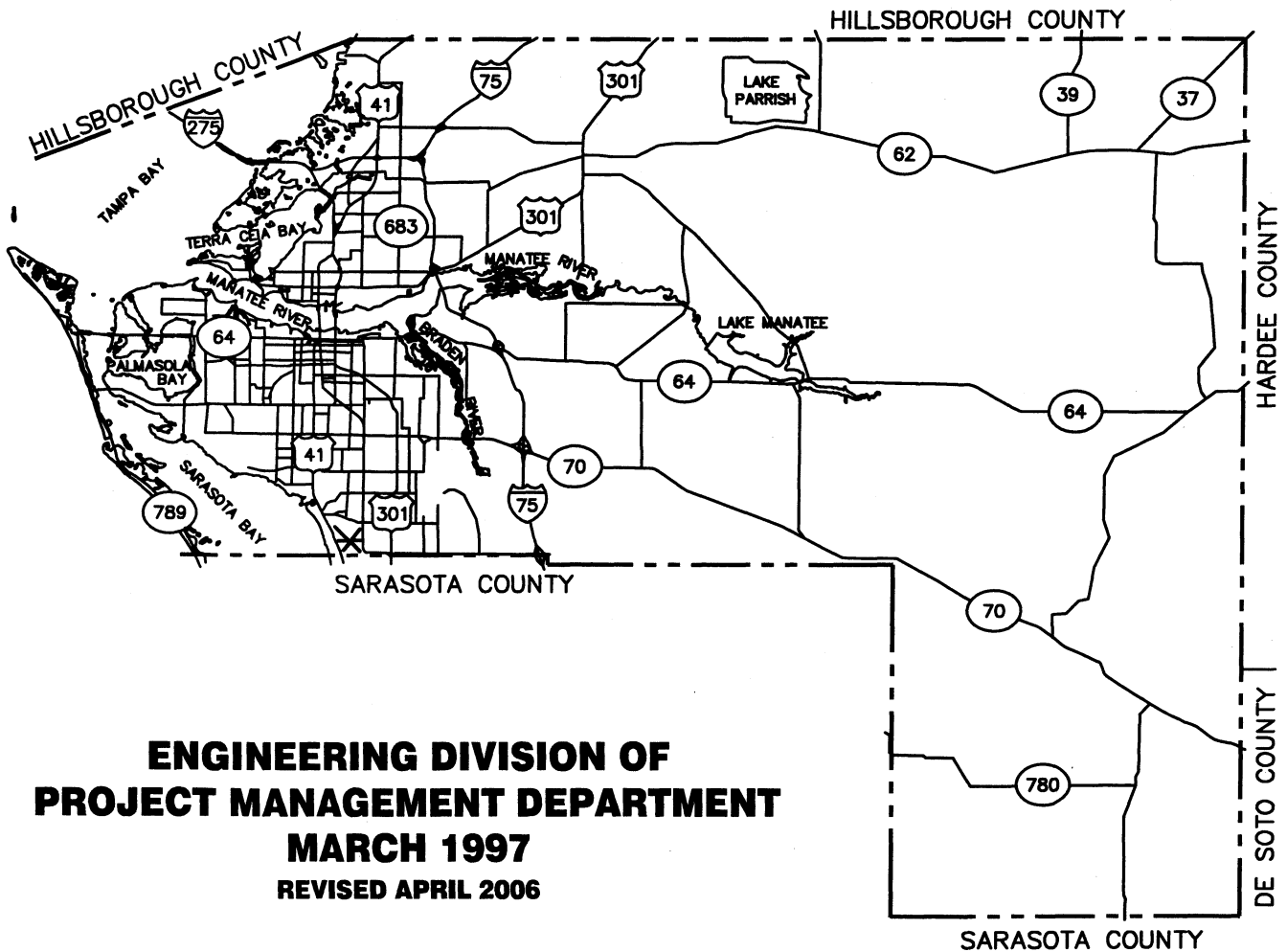

**ENGINEERING DIVISION OF  
PROJECT MANAGEMENT DEPARTMENT  
MARCH 1997  
REVISED APRIL 2006**



## TABLE OF CONTENTS

	<u>DESCRIPTION</u>	<u>PAGE NO.</u>
1.	Modifications to Existing Structures, Piping and Equipment	01 - 04
2.	Excavation, Backfill, Fill and Grading for Structures	05 - 09
3.	Trenching, Bedding and Backfill for Pipe	10 - 17
4.	Pavement Repair and Restoration	18 - 20
5.	Ductile Iron Pipe and Fittings	21 - 22
6.	Polyethylene (PE) Pressure Pipe for Lines 4" Diameter and Larger	23 - 24
7.	Polyethylene (PE) Pressure Pipe and Tubing for Lines 3" Diameter and Smaller	25 - 26
8.	Polyvinyl Chloride (PVC) Pipe and Fittings	27 - 30
9.	Installation and Testing of Pressure Pipe	31 - 34
9.	Cleaning and Disinfecting Potable Water Pipe Lines	35 - 36
11.	Polyvinyl Chloride (PVC) Pipe (Gravity Sewer)	37 - 47
12.	Fiberglass Manholes	48 - 56
13.	Valves and Appurtenances	56 - 77
14.	Precast Concrete Manholes and Wetwells	78 - 86
15.	Lift Station Specification	87 - 93
16.	Minimum Record Drawing Standards for all Record Drawings Submitted to Manatee County	94 - 95



## **MODIFICATIONS TO EXISTING STRUCTURES, PIPING AND EQUIPMENT**

### **PART 1 GENERAL**

#### **1.01 SCOPE OF WORK**

Furnish all labor, materials, equipment and incidentals required to modify, alter and/or convert existing structures as shown or specified and as required for the installation of piping, mechanical equipment and appurtenances. Existing piping and equipment shall be removed and dismantled as necessary for the performance of facility alterations in accordance with the requirements herein specified.

### **PART 2 PRODUCTS (NOT USED)**

### **PART 3 EXECUTION**

#### **3.01 GENERAL**

- A. The Contractor shall cut, repair, reuse, excavate, demolish or otherwise remove parts of the existing structures or appurtenances, as indicated on the Contract Drawings, herein specified, or necessary to permit completion of the work under this Contract. He shall dispose of surplus materials resulting from the above work in an approved manner. The work shall include all necessary cutting and bending of reinforcing steel, structural steel, or miscellaneous metal work found embedded in the existing structures.**
- B. The Contractor shall dismantle and remove all existing equipment, piping, and other appurtenances required for the completion of the work. Where called for or required, the contractor shall cut existing pipelines for the purpose of making connections thereto. Anchor bolts for equipment and structural steel removed shall be cut off one inch below the concrete surface. Surface shall be finished as specified in the Contract Documents.**
- C. At the time that a new connection is made to an existing pipeline, additional new piping, extending to and including a new valve, shall be installed. Pipe anchorage, if required, shall also be installed as directed by the Engineer.**

- D. No existing structure, equipment, or appurtenance shall be shifted, cut, removed, or otherwise altered except with the express approval of and to the extent approved by the Engineer.**
- E. When removing materials or portions of existing utility pipelines and/or structures or when making openings in walls and partitions, the Contractor shall take all precautions and use all necessary barriers and other protective devices so as not to damage the structures beyond the limits necessary for the new work, and not to damage the structures or contents by falling or flying debris. Unless otherwise permitted, line drilling will be required in cutting existing concrete.**
- F. Materials and equipment removed in the course of making alterations and additions shall remain the property of the Owner, except that items not salvageable, as determined by the Engineer and the Owner, shall become the property of the Contractor to be disposed of by him off the work site at his own place of disposal. Operating equipment shall be thoroughly cleaned, lubricated, and greased for protection during prolonged storage.**
- G. All alterations to existing utility pipes and structures shall be done at such time and in such manner as to comply with the approved time schedule. So far as possible before any part of the work is started, all tools, equipment, and materials shall be assembled and made ready so that the work can be completed without delay.**
- H. All workmanship and new materials involved in constructing the alterations shall conform to the General Specifications for the classes of work insofar as such specifications are applicable.**
- I. All cutting of existing concrete or other material to provide suitable bonding to new work shall be done in a manner to meet the requirements of the respective section of these Specifications covering the new work. When not covered, the work shall be carried on in the manner and to the extent directed by the Resident Project Representative.**
- J. Surfaces of seals visible in the completed work shall be made to match as nearly as possible the adjacent surfaces.**
- K. Non-shrink grout shall be used for setting wall castings, sleeves, leveling pump bases, doweling anchors into existing concrete and elsewhere as shown.**

- L. Where necessary or required for the purpose of making connections, the Contractor shall cut existing pipelines in a manner to provide an approved joint. Where required, he shall use flanges, or provide Dresser Couplings, all as required.
- M. The Contractor shall provide flumes, hoses, piping and other related items to divert or provide suitable plugs, bulkheads, or other means to hold back the flow of water or other liquids, all as required in the performance of the work under this Contract.
- N. Care shall be taken not to damage any part of existing buildings or foundations or outside structures.

**3.02 CONNECTING TO EXISTING PIPING AND EQUIPMENT**

The Contractor shall verify exact location, material, alignment, joint, etc. of existing piping and equipment prior to making the connections called out in the Drawings. The verifications shall be performed with adequate time to correct any potential alignment or other problems prior to the actual time of connection. A Manatee County representative must be present for all tie-ins for a visual inspection.

**3.03 REMOVAL AND ABANDONMENT OF ASBESTOS CEMENT PIPE AND APPURTENANCES**

- A. All work associated with the removal or abandonment of existing asbestos cement pipe and appurtenances shall be performed by a licensed asbestos abatement contractor or subcontractor registered in the State of Florida.
- B. The asbestos abatement contractor or subcontractor shall contact the appropriate regulatory agencies prior to removal or abandonment of any asbestos material and shall obtain all required permits and licenses and issue all required notices. The Contractor shall be responsible for all fees associated with permits, licenses and notices to the governing regulatory agencies.
- C. All work associated with removal or abandonment of asbestos cement pipe and appurtenances shall be performed in accordance with the standards listed below and all other applicable local, State, or Federal standards.
  1. Florida Administrative Code, Chapter 17-251, "Asbestos".
  2. National Emission Standards Hazardous Air Pollution (NESHAP), 40 CFR, Part 61, Subpart M, latest revision.
  3. Occupational Safety and Health Act, 29 CFR

4. **The Environmental Protection Agency (EPA) Asbestos Abatement Worker Protection Rule.**
5. **Florida Statute 455.300.**

#### **3.04 ASBESTOS CEMENT PIPE REMOVAL**

- A. **All asbestos cement pipe sections shown on the Drawings to be removed, and all related valves, fittings and appurtenances shall be removed in their entirety and disposed of by the Contractor in accordance with this Section. After removal of the facilities, all trenches shall be backfilled in accordance with the Contract Documents. The cost of disposing of the removed materials shall be borne by the Contractor.**
- B. **The Contractor shall make necessary provisions for the Engineer's representative to monitor all removal operations.**
- C. **The cutting of existing asbestos-cement (A/C, aka "Transite") pipe shall be by hand saw only. No machine cutting shall be allowed. Removal of all portions of pipe shall be double bagged prior to shipment. Longer sections of pipe removed may be shipped without double bagging. An asbestos manifest form must accompany each and every shipment of such pipe or pipe material waste to the Manatee County Lena Road Landfill. Prior to each shipment, a minimum of 24 hours notice to the Landfill field office (Phone #748-5543) is required.**

#### **3.05 IN-PLACE GROUTING OF EXISTING PIPE**

- A. **Where water and wastewater utility pipes are to be abandoned in place, they shall be filled with a sand/cement grout as specified herein. When such pipes are constructed with asbestos cement materials, the abandonment activities shall be performed by a licensed asbestos abatement contractor as specified in these Specifications.**
- B. **Grout shall be injected within the pipe sections indicated on the Drawings. The ends of these sections shall be capped and/or plugged. The grouting program shall consist of pumping sand-cement grout with suitable chemical additives at pressures necessary to fill the pipe sections shown on the Drawings to prevent the potential for future collapse.**
- C. **The pump used for grouting should be a continuous flow, positive displacement model with a pugmill type mixing vat having a minimum shaft speed of 60 rpm and incorporated as an integral part of the equipment. Alternate equipment may be used subject to the approval of the Engineer. The rate of pumping shall not exceed six (6) cubic feet per minute. The pumping pressures shall be in the range of 100 to 150 psi.**



- D. The Contractor shall provide standpipes and/or additional means of visual inspection as required by the Engineer to determine if adequate grout material has filled the entire pipe section(s). The Contractor shall make necessary provisions for the Engineer's representative to monitor all grouting operations.**
  
- E. All pipe to be abandoned shall be capped or plugged with a fitting or material that will prevent soil or other material from entering the pipe. All caps and plugs shall be subject to approval by the Engineer.**

**END OF SECTION**  
**EXCAVATION, BACKFILL, FILL AND GRADING FOR STRUCTURES**

**PART 1 GENERAL**

**1.01 SCOPE OF WORK**

- A. Structural excavation shall consist of the removal of material for the construction of foundations for structures and other excavation designated on the drawings or in these specifications.**
  
- B. Structural excavation and backfill shall consist of furnishing material, if necessary and placing and compacting backfill material around structures to the lines and grades designated on the drawings, as specified or directed by the Engineer.**

- C. **Structural excavation and backfill shall include the furnishing of all materials, equipment and other facilities which may be necessary to perform the excavations, place and compact the backfill, install sheeting and bracing, and carry out any necessary dewatering. It shall also include the wasting or disposal of surplus excavated material in a manner and in locations approved by the Engineer.**
- D. **The Contractor is responsible for the protection of every tree which is scheduled to remain in the project area. This includes trees which may or may not be shown on the plans. Every tree shall be adequately protected in place at no additional cost to the County. This includes, but is not limited to, protecting the root systems and adjusting grades as necessary for tree/root protection.**

**1.02 QUALITY ASSURANCE**

**A. Testing Agency:**

- 1. **In place soil compaction tests shall be performed by a qualified testing laboratory.**
- 2. **Compaction tests shall be taken every 500 feet, except in the road crossings or road shoulders. Tests are to be taken according to current FDOT Standards.**

**B. Reference Standards:**

- 1. **American Society for Testing and Materials (ASTM):**
  - a. **ASTM D1557, Moisture-Density Relations of Soils Using 10-lb. (4.5-kg) Rammer and 18-in. (457-mm) Drop.**

**1.03 JOB CONDITIONS**

- A. **The Contractor shall provide, operate and maintain all necessary pumps, discharge lines, well points, etc., in sufficient number and capacity to keep all excavation, bases, pits, etc., free from seepage, sanding or running water at all times throughout the period of construction.**
- B. **The Contractor shall assume all responsibility for the security of the excavation required, employing bracing, lining or other accepted means necessary to accomplish same.**
- C. **Excavated areas shall be cleared of all debris, water, slush, muck, clay and soft or loose earth and shall be conditioned to the entire satisfaction of the Engineer.**
- D. **All excavated material unsuitable for use or which will not be used shall be disposed of in a manner consistent with State and County**

**regulations.**

- E. All unsuitable organic materials, roots, logs, etc., found during excavation shall be removed by the Contractor and the trench shall be refilled with suitable material.

**PART 2 PRODUCTS**

**2.01 MATERIAL FOR CONTROLLED FILL**

- A. **Composition:** Only approved material free from organic matter and lumps of clay, shall be used for backfill. Excavated earth free from debris or organic material may be used for backfilling foundations or fill.
- B. Crushed stone and shell shall meet or exceed current FDOT Standards.

**2.02 UNSUITABLE MATERIAL**

Unsuitable material shall be defined as highly organic soil per ASTM D2487 Group PT. This includes, but is not limited to, such items as topsoil, roots, vegetable matter, trash, debris, and clays that cannot be dried sufficiently to obtain specified compaction.

**PART 3 EXECUTION**

**3.01 INSPECTION**

- A. The Contractor shall verify that work preceding the affected work of this Section has been satisfactorily completed.
- B. Conditions adversely affecting the work of this Section shall be corrected to the satisfaction of the Engineer.

**3.02 REMOVAL OF UNSUITABLE MATERIALS**

- A. The Contractor shall remove unsuitable material from within the limits of the Work.
- B. Materials meeting requirements for controlled fill shall be stockpiled as necessary and in such a manner satisfactory to the Engineer.
- C. All material excavated shall be placed so as to minimize interference with public travel and to permit proper access for inspection of the work.

**3.03 EXCAVATION**

- A. When concrete or shell subbase footing is to rest on an excavated surface, care shall be taken not to disturb the natural soil. Final removal and replacement of the foundation material and subbase compaction to grade shall not be made until just before the concrete or masonry is placed.**
- B. When any structural excavation is completed, the Contractor shall notify the Engineer who will make an inspection of the excavation. No concrete or masonry shall be placed until the excavation has been approved by the Engineer.**
- C. The elevations of the footing bottom and the base slab as shown on the Drawings, shall be considered as approximate and the Engineer may order in writing, such changes in dimensions or elevations of the footings and slab base as necessary to secure satisfactory foundations.**
- D. All excavation shall be made within an area bounded by lines five feet outside and parallel to the exterior walls of the structure to allow for correct forming, shoring and inspection of foundation work. Pouring of concrete against earth side walls shall not be permitted.**
- E. If the ground is excavated below the grade called for by the Drawings or becomes unstable due to the Contractor's carelessness or operations, the ground shall be excavated to undisturbed native soil before continuing concreting operations.**
- F. If in the opinion of the Engineer, the material at or below the normal grade of the bottom of the trench is unsuitable for pipe or structure foundation, it shall be removed to the depth directed by the Engineer and if so directed, replaced by crushed stone or washed shell.**

#### **3.04 STRUCTURAL BACKFILL**

- A. Structural backfill shall not be placed until the footings or other portions of the structure or facility have been inspected by the Engineer and approved for backfilling.**
- B. A minimum of 1-1/2" layer of lean concrete shall be placed as a working mat for the concrete base slabs and footings.**
- C. Fill shall be placed in uniform layers not more than 12" thick and compacted to a minimum of 98 percent of the maximum density determined by ASTM D1557, Method A or C, or as directed by the Engineer. The Contractor shall securely tamp the backfill with pneumatic rammer around all wall foundations. The method of compaction shall be satisfactory to the Engineer.**

- D. Compaction of structural backfill by ponding and jetting shall be permitted when, as determined by the Engineer: the backfill material is of such character that it will be self-draining when compacted; foundation materials will not soften or be otherwise damaged by the applied water; no damage from hydrostatic pressure will result to the structure. Ponding and jetting within two feet below finished subgrade shall not be permitted in roadway areas. At the discretion of the Engineer, ponding and jetting may be permitted with compaction layers not to exceed four feet. The work shall be performed without damage to the structure or embankment and in such a manner that water will not be impounded.**
- E. Surplus material not used on-site shall be removed and disposed of off-site by the Contractor. In no case shall surplus material be deposited on adjacent lands. Fill used for grading shall be placed in layers not to exceed 12 inches in thickness and shall be compacted to a density equal or greater to that of the surrounding natural ground.**

### **3.05 BACKFILLING AROUND STRUCTURES**

- A. Common fill and structural fill are specified for use as backfill against the exterior walls of the structures. Fill shall be placed in layers having a maximum thickness of eight (8) inches in loose state and shall be compacted sufficiently to prevent settlement. If compaction is by rolling or ramming, material shall be wetted down as required. Where material can be suitably compacted by jetting or puddling, the Contractor shall use one of these methods. No boulders shall be allowed to roll down the slopes and hit the walls.**
- B. Backfilling shall be carried up evenly on all walls of an individual structure simultaneously. A variation of two (2) feet in elevation will be the maximum allowable. No backfill shall be allowed against walls until the walls and their supporting slabs, if applicable, have attained sufficient strength. Backfilling shall be subjected to approval by the Engineer.**
- C. In locations where pipes pass through building walls, the Contractor shall take the following precautions to consolidate the refill up to an elevation of at least one foot above the bottom of the pipes:**
  - 1. Place structural fill in such areas for a distance of not less than three feet either side of the center line of the pipe in level layers not exceeding 6-inches in depth.**

2. **Wet each layer to the extent directed and thoroughly compact each layer with a power tamper to the satisfaction of the Engineer.**
  3. **Structural fill shall be of the quality specified under Part 2 of this Section.**
- D. **The surface of filled areas shall be graded to smooth true lines, strictly conforming to grades indicated on the grading plan. No soft spots or uncompacted areas shall be allowed in the work.**
  - E. **Temporary bracing shall be provided as required during construction of all structures to protect partially completed structures against all construction loads, hydraulic pressure and earth pressure. The bracing shall be capable of resisting all loads applied to the walls as a result of backfilling.**

**3.06 FIELD QUALITY CONTROL**

- A. **The density of soil in place shall be a minimum of 95 percent in accordance with ASTM test 1557-70T, Method A or C.**

**END OF SECTION**

## TRENCHING, BEDDING AND BACKFILL FOR PIPE

### **PART 1 GENERAL**

#### **1.01 SCOPE OF WORK**

- A. The Contractor shall furnish all labor, materials, equipment and incidentals necessary to perform all excavation, backfill, fill, grading, trench protection or other related work required to complete the piping work shown on the Drawings and specified herein. The work shall include, but not be limited to: vaults; duct conduit; pipe; roadways and paving; backfilling; required fill or borrow operations; grading; disposal of surplus and unsuitable materials; and all related work such as sheeting, bracing and dewatering.**
- B. Prior to commencing work, the Contractor shall examine the site and review test borings if available, or undertake his own subsurface investigations and take into consideration all conditions that may affect his work.**
- C. The Contractor is responsible for the protection of every tree which is scheduled to remain in the project area. This includes trees which may or may not be shown on the plans. Every tree shall be adequately protected in place at no additional cost to the County. This includes, but is not limited to protecting the root systems and adjusting grades as necessary for tree/root protection.**

#### **1.02 PROTECTION**

- A. Sheeting and Bracing in Excavations:**
  - 1. In connection with construction of underground structures, the Contractor shall properly construct and maintain cofferdams. These shall consist of: sheeting and bracing as required to support the sides of excavations, to prevent any movement which could in any way diminish the width of the excavation below that necessary for proper construction and to protect adjacent structures, existing yard pipe and/or foundation material from disturbance, undermining, or other damage. Care shall be taken to prevent voids outside of the sheeting, but if voids are formed, they shall be immediately filled and rammed.**
  - 2. Trench sheeting for pipes: no sheeting is to be withdrawn if driven below, mid-diameter of any pipe and no wood sheeting shall be cut off at a level lower than one foot above the top of any pipe unless otherwise directed by the Engineer. During the progress of the work, the Engineer may direct the Contractor in writing to leave additional wood sheeting in**



place. If steel sheeting is used for trench sheeting, removal shall be as specified above, unless written approval is given for an alternate method of removal.

3. All sheeting and bracing not left in place shall be carefully removed in such a manner as not to endanger the construction or other structures, utilities, existing piping, or property. Unless otherwise approved or indicated on the Drawings or in the Specification, all sheeting and bracing shall be removed after completion of the piping or structure, care being taken not to disturb or otherwise injure the pipeline or finished masonry. All voids left or caused by withdrawal of sheeting shall be immediately refilled with sand by ramming with tools specifically made for that purpose, by watering, or as may otherwise be directed.
4. The Contractor shall construct, to the extent he deems it desirable for his method of operation, the cofferdams and sheeting outside the neat lines of the pipeline trench or foundation unless otherwise indicated on the Drawings or directed by the Owner/Engineer. Sheeting shall be plumb and securely braced and tied in position. Sheeting, bracing and cofferdams shall be adequate to withstand all pressures to which the pipeline or structure will be subjected. Pumping, bracing and other work within the cofferdam shall be done in a manner to avoid disturbing any construction of the pipeline or the enclosed masonry. Any movement or bulging which may occur shall be corrected by the Contractor to provide the necessary clearances and dimensions.
5. Drawings of the cofferdams and design computations shall be submitted to the Engineer and approved prior to any construction. However, approval of these drawings shall not relieve the Contractor of the responsibility for the cofferdams. The drawings and computations shall be prepared and stamped by a Registered Professional Engineer in the State of Florida and shall be in sufficient detail to disclose the method of operation for each of the various stages of construction, if required, for the completion of the pipeline and substructures.

**B. Dewatering, Drainage and Flotation**

- 1. The Contractor shall construct and place all pipelines, concrete work, structural fill, bedding rock and limerock base course, in-the-dry. In addition, the Contractor shall make the final 24" of excavation for this work in-the-dry and not until the water level is a minimum of 6" below proposed bottom of excavation.**
- 2. The Contractor shall, at all times during construction, provide and maintain proper equipment and facilities to remove promptly and dispose of properly all water entering excavation and keep such excavations dry so as to obtain a satisfactory undisturbed subgrade foundation condition until the fill, structure, or pipes to be built thereon have been completed to such extent that they will not be floated or otherwise damaged by allowing water levels to return to natural elevations.**
- 3. Dewatering shall at all times be conducted in such a manner as to preserve the natural undisturbed bearing capacity of the subgrade soils at proposed bottom of excavation.**
- 4. Wellpoints may be required for dewatering the soil prior to final excavation for deeper in-ground structures or piping and for maintaining the lowered groundwater level until construction has been completed to avoid the structure, pipeline, or fill from becoming floated or otherwise damaged. Wellpoints shall be surrounded by suitable filter sand and no fines shall be removed by pumping. Pumping from wellpoints shall be continuous and standby pumps shall be provided.**
- 5. The Contractor shall furnish all materials and equipment to perform all work required to install and maintain the proposed drainage systems for handling groundwater and surface water encountered during construction of structures, pipelines and compacted fills.**
- 6. Where required, the Contractor shall provide a minimum of two operating groundwater observation wells at each structure to determine the water level during construction of the pipeline or structure. Locations of the observation wells shall be at structures and along pipelines as approved by the Engineer prior to their installation. The observation wells shall be extended to 6 inches above finished grade, capped with screw-on caps protected by 24" x 24" wide concrete base and left in place at the completion of this Project.**
- 7. Prior to excavation, the Contractor shall submit his proposed method of dewatering and maintaining dry conditions to the Engineer for approval. Such approval shall not relieve the Contractor of the responsibility for the satisfactory performance of the system. The Contractor shall be**

responsible for correcting any disturbance of natural bearing soils for damage to pipeline or structures caused by an inadequate dewatering system or by interruption of the continuous operation of the system as specified.

8. As part of his request for approval of a dewatering system, the Contractor shall demonstrate the adequacy of the proposed system and wellpoint filter sand by means of a test installation. Discharge water shall be clear, with no visible soil particles in a one quart sample. Discharge water shall not flow directly into wetlands or Waters of the State as defined by FDEP and SWFWMD.
9. During backfilling and construction, water levels shall be measured in observation wells located as directed by the Engineer.
10. Continuous pumping will be required as long as water levels are required to be below natural levels.

## **PART 2 PRODUCTS**

### **2.01 MATERIALS**

#### **A. General**

1. Materials for use as fill and backfill shall be as described below. For each material, the Contractor shall notify the Engineer of the source of the material and shall furnish the Engineer, for approval, a representative sample weighing approximately 50 pounds, at least ten calendar days prior to the date of anticipated use of such material.
2. Additional materials shall be furnished as required from off-site sources and hauled to the site.

#### **B. Structural Fill**

1. Structural fill shall be used below spread footing foundations, slab-on-grade floors and other structures as backfill within three feet of the below grade portions of structures.

2. **Structural fill material shall be a minimum of 60 percent clean sand, free of organic, deleterious and/or compressible material. Minimum acceptable density shall be 98 percent of the maximum density as determined by ASSHTO T-180. Rock in excess of 2-1/2" in diameter shall not be used in the fill material. If the moisture content is improper for attaining the specified density, either water shall be added or material shall be permitted to dry until the proper moisture content for compaction is reached.**

**C. Base Course**

**Asphalt, crushed concrete soil cement or lime rock, shall be used as base course for bituminous paved roads and parking areas.**

**D. Common Fill**

1. **Common fill material shall be free from organic matter, muck or marl and rock exceeding 2-1/2" in diameter. Common fill shall not contain broken concrete, masonry, rubble or other similar materials. Existing soil may be used to adjust grades over the site with the exception of the construction area.**
2. **Material falling within the above specification, encountered during the excavation, may be stored in segregated stockpiles for reuse. All material which, in the opinion of the Engineer, is not suitable for reuse shall be spoiled as specified herein for disposal of unsuitable materials by the Contractor.**

**E. Crushed Stone**

1. **Crushed stone may be used for pipe bedding, manhole bases, as a drainage layer below structures with underdrains and at other locations indicated on the Drawings.**
2. **Crushed stone shall be size No. 57 with gradation as noted in Table 1 of Section 901 of Florida Department of Transportation, Construction of Roads and Bridges.**

**PART 3 EXECUTION**

**3.01 FILL PLACEMENT**

**A. General**

1. **Material placed in fill areas under and around pipelines and structures shall be deposited within the lines and to the grades shown on the Drawings or as directed by the Engineer, making due allowance for settlement of the material. Fill shall be placed only on properly prepared surfaces which have been inspected and approved by the Engineer. If sufficient common**

**fill material is not available from excavation on site, the Contractor shall provide borrows as may be required.**

- 2. Limerock base course material, structural fill and screened limerock, may be provided as borrow.**
- 3. Fill shall be brought up in substantially level lifts throughout the site, starting in the deepest portion of the fill. The entire surface of the work shall be maintained free from ruts and in such condition that construction equipment can readily travel over any section. Fill shall not be placed against concrete structures until they have attained sufficient strength.**
- 4. Fill shall be dumped and spread in layers by a bulldozer or other approved method. During the process of dumping and spreading, all roots, debris and stones greater in size than specified under Materials, shall be removed from the fill areas. The Contractor shall assign a sufficient number of men to this work to insure satisfactory compliance with these requirements.**
- 5. If the compacted surface of any layer of material is determined to be too smooth to bond properly with the succeeding layer, it shall be loosened by harrowing or by another approved method before the succeeding layer is placed.**
- 6. All fill materials shall be placed and compacted "in-the-dry". The Contractor shall dewater excavated areas and is required to perform the work in such manner as to preserve the undisturbed state of the natural inorganic soil.**

### **3.02**

### **COMPACTION**

- A. Structural fill, limerock base course and screened limerock in open areas, shall be placed in layers not to exceed nine inches in depth as measured before compaction. Each layer shall be compacted by a minimum of six coverages (3 passes each way) with the equipment described below, to at least 98 percent of the maximum density, as determined by AASHTO T-180. Incidental compaction due to traffic by construction equipment will not be credited toward the required minimum six coverages.**
- B. Common fill shall be placed and compacted in a manner similar to that described above for structural fill, with the following exceptions: layer thickness prior to compaction may be increased to 12-inches in open areas; and common fill except dike fill, required below water level in peat excavation areas may be placed as one lift, in-the-wet, to an elevation one foot above the water level at the time of filling.**
- C. Compaction equipment in open areas shall consist of a medium-heavy vibrator roller (minimum static weight of 10 tons) operated at resonant frequency and at a speed of 2 fps or less or other compaction equipment approved by the Engineer.**
- D. Areas adjacent to pipelines, structures and other confined areas inaccessible to the vibrator roller shall be compacted with a manually operated sled-type vibratory compactor. The Contractor shall also conform to additional backfill requirements at pipelines and structures as specified in the Contract Documents. Compaction of the fill by such means shall be to the same degree of compaction as obtained by the rubber-tired equipment, and the Engineer may make the necessary tests to determine the amount of compactive effort necessary to obtain equal compaction. Unless such tests indicate that modifications may be made, the fill compacted by mechanical compactors shall be placed in 6-inch layers and thoroughly tamped over the entire surface.**

**Compaction equipment is subject to approval by the Engineer.**

- E. It is the intention that the fill materials with respect to moisture be used in the condition they are excavated insofar as this is practicable. Material which is too wet shall be spread on the fill area and permitted to dry, assisted by harrowing if necessary, until the moisture content is reduced to allowable limits.**
- F. If the Engineer shall determine that added moisture is required, water shall be applied by sprinkler tanks or other sprinkler systems, which will insure uniform distribution of the water over the area to be treated and give complete and accurate control of the amount of water to be used. If too much water is added, the area shall be permitted to dry before compaction is continued.**

- G. The Contractor shall supply all hose, piping, valves, sprinklers, pumps, sprinkler tanks, hauling equipment and all other materials and equipment necessary to place the water in the fill in the manner specified.**

**3.03****TRENCH EXCAVATION AND BACKFILLING**

- A. Excavation for all trenches required for the installation of pipes and electrical ducts shall be made to the depths indicated on the Drawings and in such manner and to such widths as will give suitable room for laying the pipe or installing the ducts within the trenches.**
- B. Rock shall be removed to a minimum 6" clearance around the bottom and sides of all the pipe or ducts being laid.**
- C. Where pipes or ducts are to be laid in limerock bedding or encased in concrete, the trench may be excavated by machinery to or just below the designated subgrade provided that the material remaining in the bottom of the trench is no more than slightly disturbed.**
- D. Where the pipes or ducts are to be laid directly on the trench bottom, the lower part of the trenches shall not be excavated to grade by machinery. The last of the material being excavated manually, shall be done in such a manner that will give a flat bottom true to grade so that pipe or duct can be evenly supported on undisturbed material. Bell holes shall be made as required.**
- E. Backfilling over pipes shall begin as soon as practicable after the pipe has been laid, jointed and inspected and the trench filled with suitable compacted material to the mid-diameter of the pipe.**
- F. Backfilling over ducts shall begin not less than three days after placing concrete encasement.**
- G. All backfilling shall be prosecuted expeditiously and as detailed on the Drawings.**
- H. Any space remaining between the pipe and sides of the trench shall be packed full by hand shovel with selected earth, free from stones having a diameter greater than 2" and thoroughly compacted with a tamper as fast as placed, up to a level of one foot above the top of the pipe.**
- I. The filling shall be carried up evenly on both sides with at least one man tamping for each man shoveling material into the trench.**



- J. The remainder of the trench above the compacted backfill, as just described above, shall be filled and thoroughly compacted by rolling, ramming, or puddling, as the Engineer may direct, sufficiently to prevent subsequent settling.

### **3.04 GRADING**

- A. Grading shall be performed at such places as are indicated on the Drawings, to the lines, grades and elevations shown or as directed by the Engineer and shall be made in such a manner that the requirements for formation of embankments can be followed. All unacceptable material encountered, of whatever nature within the limits indicated, shall be removed and disposed of as directed. During the process of excavation, the grade shall be maintained in such condition that it will be well drained at all times. When directed, temporary drains and drainage ditches shall be installed to intercept or divert surface water which may affect the prosecution or condition of the work.
- B. If at the time of excavation it is not possible to place any material in its proper section of the permanent pipeline structure, it shall be stockpiled in approved areas for later use.
- C. Minute adjustments in lines or grades may be made if found necessary as the work progresses, due to discrepancies on the Drawings or in order to obtain satisfactory construction.
- D. Stones or rock fragments larger than 2-1/2" in their greatest dimensions shall not be permitted in the top 6" of the subgrade line of all dikes, fills or embankments.
- E. All fill slopes shall be uniformly dressed to the slope, cross-section and alignment shown on the Drawings, or as directed by the Engineer.
- F. In cuts, all loose or protruding rocks on the back slopes shall be barred loose or otherwise removed to line or finished grade of slope. All fill slopes shall be uniformly dressed to the slope, cross section and alignment shown on the Drawings or as directed by the Engineer.
- G. No grading is to be done in areas where there are existing pipelines that may be uncovered or damaged until such lines which must be maintained are relocated, or where lines are to be abandoned and removed, all required valves are closed and drains plugged at manholes.

**END OF SECTION**  
**PAVEMENT REPAIR AND RESTORATION**

**PART 1 GENERAL**

**1.01 SCOPE OF WORK**

The Contractor shall furnish all labor, materials, equipment, obtain County or State right-of-way permits and incidentals required and remove and replace pavements over trenches excavated for installation of water lines and appurtenances as shown on the Contract Drawings.

**1.02 GENERAL**

- A. The Contractor shall take before and after photographs.**
- B. The Contractor shall repair in a manner satisfactory to the County or State, all damage done to existing structures, pavement, driveways, paved areas, curbs and gutters, sidewalks, shrubbery, grass, trees, utility poles, utility pipe lines, conduits, drains, catch basin, flagstones, or stabilized areas or driveways and including all obstructions not specifically named herein, which results from this Project.**
- C. The Contractor shall keep the surface of the backfilled area of excavation in a safe traffic bearing condition and firm and level with the remaining pavement until the pavement is restored in the manner specified herein. All surface irregularities that are dangerous or obstructive to traffic are to be removed. The repair shall conform to applicable requirements of Manatee County Transportation Department requirements for pavement repair and as described herein, including all base, subbase and asphalt replacement.**
- D. All materials and workmanship shall meet or exceed County requirements and as called for in the Contract Documents and nothing herein shall be construed as to relieve the Contractor from this responsibility.**
- E. All street, road and highway repair shall be made in accordance with the details indicated on the Drawings and in accordance with the applicable requirements and approval of affected County and State agencies.**

**PART 2 PRODUCTS**

**2.01 PAVEMENT SECTION**

- A. Asphaltic concrete shall consist of asphalt cement, coarse aggregate, fine aggregate and mineral filler conforming to FDOT Type SIII Asphalt. Pavement replacement thickness shall match that removed but in no case shall be less than 1-1/2" compacted thickness. All asphalt concrete pavement shall be furnished, installed and tested in accordance with FDOT Specifications for Road and Bridge Construction.**
- B. Asphalt or crushed concrete or approved equal base material shall be furnished and installed under all pavement sections restored under this Contract. Asphalt base shall have a minimum 6" compacted thickness, meet requirements for FDOT ABC III (Minimum Marshall Stability of 1000) and be furnished, installed and tested in accordance with the requirements of the FDOT Standards. Crushed concrete base shall be 10" minimum compacted thickness. Crushed concrete aggregate material shall have a minimum LBR of 140 compacted to 99% T-180 AASHTO density. Asphalt base and crushed concrete base are acceptable. Other bases shall be submitted for approval.**
- C. Prime and tack will be required and applied in accordance with Section 300 - FDOT Specifications: Prime and Tack Coat for Base Courses.**

## **PART 3 EXECUTION**

### **3.01 CUTTING PAVEMENT**

- A. The Contractor shall saw cut in straight lines and remove pavement as necessary to install the new pipelines and appurtenances and for making connections to existing pipelines.**
- B. Prior to pavement removal, the Contractor shall mark the pavement for cuts nearly paralleling pipe lines and existing street lines. Asphalt pavement shall be cut along the markings with a rotary saw or other suitable tool. Concrete pavement shall be scored to a depth of approximately two (2) inches below the surface of the concrete along the marked cuts. Scoring shall be done by use of a rotary saw, after which the pavement may be broken below the scoring with a jackhammer or other suitable equipment.**
- C. The Contractor shall not machine pull the pavement until it is completely broken and separated along the marked cuts.**
- D. The pavement adjacent to pipe line trenches shall neither be disturbed or damaged. If the adjacent pavement is disturbed or damaged, irrespective of cause, the Contractor shall remove and replace the pavement. In addition, the base and sub-base shall be restored in accordance with these Specifications, Florida Dept. of Transportation Standard Specifications and as directed by the Engineer.**

### **3.02 PAVEMENT REPAIR AND REPLACEMENT**

- A. The Contractor shall repair, to meet or exceed original surface material, all existing pavement cut or damaged by construction under this Contract. He shall match the original grade unless otherwise specified or shown on the Drawings. Materials and construction procedures for base course and pavement repair shall conform to those of the Florida Dept. of Transportation.**
  
- B. The Contractor's repair shall include the preparation of the subbase and base, place and maintain the roadway surface, any special requirements whether specifically called for or implied and all work necessary for a satisfactory completion of this work. Stabilized roads and drives shall be finished to match the existing grade. Dirt roads and drives shall have the required depth of backfill material as shown on the Contract Drawings.**
  
- C. The width of all asphaltic concrete repairs shall extend the full width and length of the excavation or to the limits of any damaged section. The edge of the pavement to be left in place shall be cut to a true edge with a saw or other approved method so as to provide a clean edge to abut the repair. The line of the repair shall be reasonably uniform with no unnecessary irregularities.**

### **3.03 MISCELLANEOUS RESTORATION**

**Sidewalks cut or damaged by construction shall be restored in full sections or blocks to a minimum thickness of four inches. Concrete curb or curb and gutter shall be restored to the existing height and cross section in full sections or lengths between joints. RCP pipe shall be repaired or installed in accordance with manufacturer's specifications. Grassed yards, shoulders and parkways shall be restored to match the existing sections with grass sod of a type matching the existing grass.**

### **3.04 SPECIAL REQUIREMENTS**

The restoration of all surfaces, as described herein, disturbed by the installation of pipelines shall be completed as soon as is reasonable and practical. The complete and final restoration of both paved and shell stabilized roads within a reasonable time frame is of paramount importance. To this end, the Contractor shall, as part of his work schedule, complete the restoration of any area of road within five weeks after removing the original surface. Successful leak testing shall be performed prior to restoring any area of road. All restoration and replacement or repairs are the responsibility of the Contractor.

**3.05 CLEANUP**

After all repair and restoration or paving has been completed, all excess asphalt, dirt and other debris shall be removed from the roadways. All existing storm sewers and inlets shall be checked and cleaned of any construction debris.

**3.06 MAINTENANCE OR REPAIR**

All wearing surfaces shall be maintained by the Contractor in good order suitable for traffic prior to completion and acceptance of the work.

**END OF SECTION  
DUCTILE IRON PIPE AND FITTINGS**

**PART 1 GENERAL**

**1.01 SCOPE OF WORK**

- A. The Contractor shall furnish all labor, materials, equipment and incidentals required to install ductile iron pipe and restrained joint ductile iron pipe and cast iron or ductile iron restrained joint fittings, complete, as shown on the Drawings and specified in these Standards.**
- B. Fittings are noted on the drawings for the Contractor's convenience and do not relieve him from laying and jointing different or additional items where required.**
- C. The Contractor shall furnish all labor, materials, equipment and incidentals required to install push-on joint or restrained joint ductile iron pipe, complete as shown on the Drawings and Specifications.**
- D. Newly installed pipe shall be kept clean and free of all foreign matter.**

**1.02 SUBMITTALS**

- A. The Contractor shall submit to the Engineer, within ten days after receipt of Notice to Proceed, a list of materials to be furnished, the names of the suppliers and the appropriate shop drawings for all ductile iron pipe and fittings.
- B. The Contractor shall submit the pipe manufacturer's certification of compliance with the applicable sections of the Specifications.

**PART 2 PRODUCTS**

**2.01 MATERIALS**

- A. Ductile iron pipe shall conform to ANSI/AWWA C150/A21.50 and ANSI/AWWA C151/A21.51. Thickness of pipe shall be Class 50 or pressure Class 350. All pipe not buried shall be Class 53. All ductile iron pipe shall be clearly marked on the outside of the barrel to readily identify it from cast iron.
- B. Unrestrained joint pipe shall be supplied in lengths not to exceed 21 ft. Unless otherwise called for in the Contract Documents, unrestrained joint pipe shall be either the rubber-ring type push-on joint or standard mechanical joint pipe as manufactured by the American Cast Iron Pipe Company, U.S. Pipe and Foundry Company, or approved equal.
- C. All fittings shall be pressure rated for 350 psi and meet the requirement of AWWA C110 or AWWA C153. Rubber gaskets shall conform to ANSI A21.11 for mechanical and push-on type joints for diameters up to 14" diameter. Gaskets for 16" diameter and larger pipe shall be EPDM (Ethylene-Propylene Dine Monomer) such as the "Fastite Gasket" of American Ductile Iron Pipe Co., or approved equal.
- D. 1. Water Mains

All ductile iron pipe and fittings shall have a standard thickness cement lining on the inside in accordance with AWWA/ANSI C104/A21.4 and a coal tar enamel coating on the outside. The coal tar enamel shall be in accordance with ANSI A21.4. All interior linings shall be EPA/NSF approved.

**2. Force Main Fittings**

All ductile iron fittings shall have a factory applied fusion bonded epoxy or epoxy and polyethylene lining on the inside in accordance with manufacturer's specifications and a coal tar enamel coating on the outside. The coal tar enamel shall be in accordance with ANSI A21.4. The interior lining is to be based on manufactures's recommendation for long-term exposure to raw sewage. It shall have a minimum ten year warranty covering failure of the lining and bond failure between liner and pipe.



- E. Restrained joints shall be provided at all horizontal and vertical bends and fittings, at casings under roads and railroads and at other locations shown on the Contract Drawings. Restrained joint pipe fittings shall be designed and rated for the following pressures:

350 psi for pipe sizes up to and including 24" diameter

250 psi for pipe sizes 30" diameter and above

## 2.02 IDENTIFICATION

- A. Each length of pipe and each fitting shall be marked with the name of the manufacturer, size and class and shall be clearly identified as ductile iron pipe. All gaskets shall be marked with the name of the manufacturer, size and proper insertion direction.
- B. Pipe shall be spiral wrapped, poly wrapped or painted blue for potable water mains, purple for reclaimed water mains and green for sewage force mains. All potable water pipe shall be NSF certified and copies of lab certification shall be submitted to the Engineer.

**END OF SECTION**  
**POLYETHYLENE (PE) PRESSURE PIPE**  
**(AWWA SPECIFICATIONS C-906-90)**  
**FOR LINES 4" DIAMETER AND LARGER**

## PART 1 GENERAL

### 1.01 SCOPE OF WORK

- A. The Contractor shall furnish all labor, materials, equipment and incidentals required to install polyethylene pressure pipe, fittings and appurtenances as shown on the Drawings and specified in the Contract Documents and these Standards.
- B. Newly installed pipe shall be kept clean and free of all foreign matter.
- C. All pipe shall be correctly color coded (blue for water, purple for reclaimed water and green for sewer) using the pipe coloring itself, or embedded colored lettering, or striped, or spiral wrap tape or a properly colored sleeve.



## **1.02 QUALIFICATIONS**

All polyethylene pipe, fittings and appurtenances shall be furnished by a single manufacturer who is fully experienced, reputable and qualified in the manufacture of the items to be furnished.

## **1.03 SUBMITTALS**

- A. The Contractor shall submit to the Engineer, within ten days after receipt of Notice to Proceed, a list of materials to be furnished, the names of the suppliers and the appropriate shop drawings for all polyethylene pipe and fittings.**
- B. The Contractor shall submit the pipe manufacturer's certification of compliance with the applicable sections of the Specifications.**
- C. The Contractor shall submit shop drawings showing installation method and the proposed method and specialized equipment to be used.**

## **PART 2 PRODUCTS**

### **2.01 POLYETHYLENE PRESSURE PIPE**

- A. Polyethylene pipe and tubing 4" diameter and larger shall be pressure Class 190, DR 9.3 "Driscopipe 8600" by Phillips Driscopipe, Inc., or equal, meeting the requirements of AWWA C906 (latest revision) and the following requirements:**

**Material Designation PE 3408**

**Material Classification ASTM D-1248 III C5 P34**

**Cell Classification PE 334434C**

**Hydrostatic Design Basis PPI TR-3**

### **2.02 JOINTS**

- A. Where PE pipe is joined to PE pipe, it shall be by thermal butt fusion. Thermal fusion shall be accomplished in accordance with the recommendations of the pipe manufacturer and fusion equipment supplier. The Contractor installing thermal butt fused PE pipe shall have a minimum of five years experience performing this type of work.**
- B. Flanged joints and molded fittings shall be in accordance with AWWA C906.**

**PART 3 EXECUTION**

**3.01 INSTALLING POLYETHYLENE PRESSURE PIPE AND FITTINGS**

- A. All polyethylene pressure pipe shall be installed by direct bury, directional bore, or a method approved by the Owner/Engineer prior to construction. If directional bore is used, or if directed by the Owner/Engineer, the entire area of construction shall be surrounded by silt barriers during construction.
- B. Direct bury pipe shall have 3" detectable metallic tape of the proper color placed directly above the pipe and 12" below finished grade or 6" detectable tape between 12" and 24" below finished grade.

**3.02 INSPECTION AND TESTING**

All pipe lines shall remain undisturbed for 24 hours to develop complete strength at all joints. All pipe lines shall be subjected to a hydrostatic pressure and leak test for two (2) hours at 180 psi for water and reclaimed water lines, and 150 psi for sewer force mains. All leaks shall be repaired and retested as approved by the Engineer. Prior to testing, the pipe lines shall be supported in an approved manner to prevent movement during tests.

**END OF SECTION  
POLYETHYLENE (PE) PRESSURE PIPE AND TUBING  
(AWWA SPECIFICATIONS C-901)  
FOR LINES 3" DIAMETER AND SMALLER**

**PART 1 GENERAL**

**1.01 SCOPE OF WORK**

- A. The Contractor shall furnish all labor, materials, equipment and incidentals required to install polyethylene pressure pipe, fittings and appurtenances as shown on the Drawings and specified in the Contract Documents.

- B. Newly installed pipe shall be kept free of all foreign matter.
- C. All pipe shall be correctly color coded (blue for water, purple for reclaimed water and green for sewer) using the pipe coloring itself, or embedded colored lettering, or a properly colored sleeve.

**1.02 QUALIFICATIONS**

All polyethylene pipe, fittings and appurtenances shall be furnished by a single manufacturer who is fully experienced, reputable and qualified in the manufacture of the items to be furnished.

**1.03 SUBMITTALS**

- A. The Contractor shall submit to the Engineer, within ten days after receipt of Notice to Proceed, a list of materials to be furnished, the names of the suppliers and the appropriate shop drawings for all polyethylene pipe and fittings.
- B. The Contractor shall submit the pipe manufacturer's certification of compliance with the applicable sections of the Specifications.
- C. The Contractor shall submit shop drawings showing installation method and the proposed method and specialized equipment to be used.

**PART 2 PRODUCTS**

**2.01 POLYETHYLENE PRESSURE PIPE**

- A. Polyethylene pipe and tubing 3" diameter and smaller shall be pressure Class 200, DR 9 "Driscopipe 5100", Endo Pure by Endot, or equal, meeting the requirements of AWWA C901 (latest revision) and the following ASTM requirements:

**Material Designation PPI/ASTM PE 3408**  
**Material Classification ASTM D-1248III C5 P34**

Cell Classification      ASTM D-3350

**2.02      JOINTS**

- A.    Where PE pipe is joined to PE pipe, it shall be by thermal butt fusion. Thermal fusion shall be accomplished in accordance with the recommendations of the pipe manufacturer and fusion equipment supplier. The Contractor installing thermal butt fused PE pipe shall have a minimum of five years experience performing this type of work.**
  
- B.    Mechanical joints and fittings shall meet the requirements of: AWWA C901, ASTM D3350 and ASTM D3140.**

**PART 3      EXECUTION**

**3.01      INSTALLING POLYETHYLENE PRESSURE PIPE AND FITTINGS**

- A.    All polyethylene pressure pipe shall be installed by direct bury, directional bore, or a method approved by the Owner/Engineer prior to construction. If directional bore is used, or if directed by the Owner/Engineer, the entire area of construction shall be surrounded by silt barriers during construction.**
  
- B.    Direct bury pipe shall have 3" detectable metallic tape of the proper color placed directly above the pipe and 12" below finished grade or 6" detectable tape between 12" and 24" below finished grade.**

**3.02      INSPECTION AND TESTING**

**All pipe lines shall remain undisturbed for 24 hours to develop complete strength at all joints. All pipe lines shall be subjected to a hydrostatic pressure and leak test for two (2) hours at 180 psi for water and reclaimed water or 150 psi for sewer force mains. All leaks shall be repaired and retested as approved by the Engineer. Prior to testing, the pipe lines shall be supported in an approved manner to prevent movement during tests.**

**END OF SECTION**  
**POLYVINYL CHLORIDE (PVC) PIPE AND FITTINGS**  
**(AWWA SPECIFICATIONS C-900 & C-905)**

**PART 1      GENERAL**

**1.01          SCOPE OF WORK**

The Contractor shall furnish all labor, materials, equipment and incidentals required to install the plastic piping, fittings and appurtenances complete and ready for use as specified in the Contract Documents and these Standards.

**1.02          DESCRIPTION OF SYSTEM**

The Contractor shall install the piping in the locations as shown on the Drawings.

**1.03          QUALIFICATIONS**

All plastic pipe, fittings and appurtenances shall be furnished by a single manufacturer who is fully experienced, reputable, qualified and specializes in the manufacture of the items to be furnished. The pipe and fittings shall be designed, constructed and installed in accordance with the best practices and methods and shall comply with these Specifications.

**1.04          SUBMITTALS**

- A. The Contractor shall submit shop drawings to the Engineer including, but not limited to, dimensions and technical specifications for all piping.**
- B. The Contractor shall submit to the Engineer, samples of all materials specified herein.**
- C. The Contractor shall submit and shall comply with pipe manufacturer's recommendation for handling, storing and installing pipe and fittings.**
- D. The Contractor shall submit pipe manufacturer's certification of compliance with these Specifications.**

**1.05 TOOLS**

The Contractor shall supply special tools, solvents, lubricants, and caulking compounds required for proper installation.

**PART 2 PRODUCTS**

**2.01 MATERIALS**

**A. Pressure Class-Rated Polyvinyl Chloride (PVC) Pipe**

1. Pressure class-rated PVC pipe and accessories four to twelve inches (4"-12") in diameter, where shown or as specified on the Drawings, shall meet the requirements of AWWA Specification C-900 "Polyvinyl Chloride (PVC) Pressure Pipe". Pipe shall be Class 150, meeting requirements of Dimension Ratio (DR) 18 and shall have the dimension of ductile iron outside diameters. Each length of pipe shall be hydrotested to four (4) times its class pressure by the manufacturer in accordance with AWWA C-900.

2. **PVC pipe 14 through 36 inches shall meet the requirements of AWWA Standard C-905, Polyvinyl Chloride (PVC) Water Transmission Pipe. Pipe 14 through 24 inches for potable and reclaimed water shall meet the requirements for dimension ratio (DR) 18. Each length of pipe shall be tested at twice the pressure rating (PR 235 psi) for a minimum dwell of 5 seconds in accordance with AWWA C-905. Fourteen inch (14") through 36" pipe for sewer force mains shall meet AWWA C-905 requirements for dimension ratio (DR) 21. Each length of pipe shall be tested at twice the pressure rating (PR 200 psi) for a minimum dwell of 5 seconds in accordance with AWWA C-905. Pipe shall be listed by Underwriters Laboratories. Provisions shall be made for expansion and contraction at each joint with an elastomeric ring, and shall have an integral thickened bell as part of each joint. PVC Class pipe shall be installed as recommended by the manufacturer. Pipe shall be furnished in nominal lengths of approximately 20 feet, unless otherwise directed by the Engineer. Pipe and accessories shall bear the NSF mark indicating pipe size, manufacturer's names, AWWA and/or ASTM Specification number, working pressure, and production code.**
3. **Gaskets for 16" diameter and larger pipe used for potable water shall be EPDM (Ethylene-Propylene Dine Monomer).**
4. **PVC pipe 3" and less in diameter may be constructed using pipe conforming to ASTM D2241 with push-on joints. Pipe shall be 200 psi pipe-SDR 21 unless otherwise specified by the Engineer. This PVC pipe shall not be used for working pressures greater than 125 psi.**
5. **Pipe shall be blue for potable water mains, green for sewage force mains and purple for reclaimed water mains. All potable water pipe  
  
shall be NSF certified and copies of lab certification shall be submitted to the Engineer.**
6. **Where colored pipe is unavailable, white PVC color coded spiral wrapped pipe shall be installed.**

**B. Joints**

1. **The PVC joints for pipe shall be of the push-on type unless**

otherwise directed by the Engineer so that the pipe and fittings may be connected on the job without the use of solvent cement or any special equipment. The push-on joint shall be a single resilient gasket joint designed to be assembled by the positioning of a continuous, molded resilient ring gasket in an annular recess in the pipe or fitting socket and the forcing of the plain end of the entering pipe into the socket, thereby compressing the gasket radially to the pipe to form a positive seal. The gasket and annular recess shall be designed and shaped so that the gasket is locked in place against displacement as the joint is assembled. The resilient ring joint shall be designed for thermal expansion or contraction with a total temperature change of at least 75 degrees F in each joint per length of pipe. The bell shall consist of an integral wall section with a solid cross section elastomeric ring which shall meet requirements of ASTM F-477. The thickened bell section shall be designed to be at least as strong as the pipe wall. Lubricant furnished for lubricating joints shall be nontoxic, shall not support the growth of bacteria, shall have no deteriorating effects on the gasket or pipe material, and shall not impart color, taste, or odor to the water. Gaskets shall be suitable for use with potable water, reclaimed water or sanitary sewer as applicable.

2. Restrained joints shall be provided at all horizontal and vertical bends and fittings, at casings under roads and railroads and at other locations shown on the Contract Drawings. PVC joints for pipe shall be restrained by the following methods: thrust blocks, restraining glands such as Certa-Lok Restraining Joint Municipal Water Pipe by the Certain Teed Corporation of Valley Forge, PA, or approved equal. All Grip, Star Grip by Star Products, MJR by Tyler Pipe, Tyler, Texas. Restrained joint PVC pipe shall be installed in strict accordance with the manufacturer's recommendation.

### C. Fittings

1. All fittings for class-rated PVC pipe shall be ductile iron with mechanical joints and shall conform to the specifications for ductile iron fittings, unless otherwise directed. Class 200, C-900 PVC fittings are allowable for sewage force main applications up to and including 12" diameter only. DR ratio shall be the same as the pipe.
2. The manufacturer of the pipe shall supply all polyvinyl chloride



accessories as well as any adapters and/or specials required to perform the work as shown on the Drawings and specified herein. Standard double bell couplings will not be accepted where the pipe will slip completely through the coupling.

**PART 3 EXECUTION**

**3.01 INSTALLATION**

The Contractor shall install the plastic pipe in strict accordance with the manufacturer's technical data and printed instructions. Direct bury pipe shall have 3" detectable metallic tape of the proper color placed directly above the pipe 12" below finished grade or 6" detectable tape between 12" and 24" below grade.

**3.02 INSPECTION AND TESTING**

All pipe lines shall remain undisturbed for 24 hours to develop complete strength at all joints. All pipe lines shall be subjected to a hydrostatic pressure test for two (2) hours, at full working pressure, but not less than 180 psi for water and reclaimed water and 150 psi for sewer force main. All visible leaks shall be repaired and retested for approval by the County. Prior to testing, the pipelines shall be supported in a manner approved by the Engineer to prevent movement during tests.

**END OF SECTION**  
**INSTALLATION AND TESTING OF PRESSURE PIPE**

**1.01**

**INSTALLING PIPE AND FITTINGS**

- A. The Contractor shall install all pipe in accordance with the recommendations of the pipe manufacturer and as specified herein.**
- B. The Contractor shall take care in handling, storage and installation of pipe and fittings to prevent injury to the pipe or coatings. All pipe and fittings shall be examined before installation and pipe which is deemed to be defective by the Owner/Engineer shall not be installed.**
- C. The Contractor shall thoroughly clean and keep thoroughly clean, all pipe and fittings prior to during and after installation.**

- D. The Contractor shall lay the pipe to the lines and grades shown on the Contract Drawings with bedding and backfill as shown on the Drawings or called out in the Contract Documents. Blocking under the pipe shall not be permitted except through casing sleeves.**
- E. The Contractor shall keep the open ends of all pipe closed with a tightly fitting plug when installation is not in progress or the potential exists for dirt or debris to enter the pipe.**
- F. The pipe or accessories shall not be dropped into the trench under any circumstances.**
- G. The Contractor shall construct all water mains pursuant to the provisions of "Recommended Standards for Water Works", Part 8, incorporated by reference in Rule 17-555.330(3), F.A.C.**

**1.02 PROCEDURE FOR TESTING WATER LINES, FORCE MAINS AND RECLAIMED WATER LINES**

- A. The Engineer must call in to schedule all testing. A 48-hour notice is needed prior to testing. A letter stating the reasons testing should be scheduled ahead of other jobs must accompany all emergency testing requests.**
- B. Engineer and Contractor must be present for all testing, except for testing tapping valves and sleeves.**
- C. All pressure pipe lines shall remain undisturbed for 24 hours to develop complete strength at all joints. All pipe lines shall be subjected to a hydrostatic pressure test for two (2) hours at full working pressure, but not less than 180 psi for water/reclaimed (150 psi for force main). Maximum length of pipe to be tested at one time is 2,600 feet. If line is longer than 2,600 feet and cannot be sectioned in 2,600 feet (max.) lengths, the allowable leakage will be figured at 2,600 feet.**
- D. Allowable leakage shall be determined by AWWA C600 table for hydrostatic tests. Leakage shall be defined as the quantity of water that must be supplied into the newly laid pipe, or any valved section thereof; to maintain the test pressure after the air in the pipe line has been expelled and the pipe has been filled with water.**
- E. All digging on the job site in the right-of-way must be completed before any testing of water or sewer. Any digging or boring across water or sewer lines after they have been tested may result in a**

retest of the lines at the County's request.

- F. All water and sewer lines will be installed per approved construction plans by the County. If any revisions or changes are made after initial testing, lines will be re-tested at the County's request.**
- G. Disconnect water supply during test.**
- H. All force mains will be tested from the valves in the valve vault at the lift station to the point of connection whether it be against a valve on another force main or into a manhole.**
- I. All services to be aboveground during test. The services should be the correct length so they will be one (1) foot inside right-of-way line.**
- J. All fire hydrant gate valves to be open during test.**
- K. All visible leaks are to be repaired, regardless of the amount of leakage.**
- L. Check gauge pressure periodically during test. If test pressure drops to 175 psi for water/reclaimed lines or to 145 psi for force mains during test, the line must be repumped back to 180 psi for water/reclaimed (150 psi force mains) and the amount of leakage measured. The test will continue on with the remaining time left. At the end of the test, the line must be repumped again back to 180 psi (150 psi for force main) and the amount of leakage measured and added to any previous leakage determined earlier in the test.**
- M. After the line passes the test, the pressure will be blown off from the opposite end of line from the gauge location. Fire hydrants, services and end-of-line blow offs will be opened to demonstrate they were on line during the test.**
- N. At end of test, the test gauge must return to zero. The pressure gauge must read 0 psi to a maximum of 300 psi in 5 psi increments.**

- O. The section of line being tested must be identified on the charge sheet. The length and size of pipe, the exact area being tested and the valves being tested against, must be identified. Use Station numbers if available.
- P. A punch list must be made at the end of all tests.
- Q. A copy of the charge sheet will be given to the Engineer and the Contractor at the end of the test.

**1.03 INSPECTION/TESTING PROCEDURE COVERING BORED PIPE LINES OR CASING AND CONDUITS INSTALLED ACROSS PREVIOUSLY TESTED AND/OR COUNTY ACCEPTED WATER AND SEWER PIPE WITHIN DEVELOPMENT PROJECTS UNDER ACTIVE CONSTRUCTION**

- A. Prior to testing water and sewer lines, every effort will be made to install sleeves for underground utilities that will cross these water and sewer lines or services.
- B. Where it has not been possible to pre-install sleeves prior to testing and bores or conduits are required, it is the responsibility of the utility company and/or their Contractor performing the work to provide Manatee County Public Works Department or the Engineer of Record with accurate horizontal and vertical as-built information of the sleeves, bores and conduits installed by said utility company. This applies to all bores and conduits crossing water and sewer lines.
- C. Procedures to be followed for installation of conduits, pipe lines and bores that will cross, or be closer than 5'-0" horizontally and 18 inches vertically to, previously tested water and sewer lines that are still under the ownership of the developer/contractor.
  - 1) Notify the owner and obtain the best as-built information available. Allow sufficient time for the owner to field locate the existing pipe lines.
  - 2) Submit drawings of proposed location to the Owner and Manatee County Public Works Utility Location Section for review.
  - 3) Obtain a County Right-of-Way Use Permit if the work area is within a dedicated area of right-of-way.

- 4) Perform installation in the presence of a County representative. Call (941) 792-8811, ext. 5061 or ext. 5069 with at least two (2) working days notice.
  - 5) Submit two (2) copies of as-built information to the Owner to incorporate into the record drawings to be submitted to the County.
  - 6) Failure to follow steps 2) thru 5) will result in additional charges for retesting the previously tested water and sewer lines.
- D. Procedures to be followed for installation of conduits, pipe lines and bores crossing or closer than 5'-0" horizontally and 18 inches vertically to previously tested water and sewer lines that have been previously accepted by Manatee County:
- 1) Obtain record drawing information from the County.
  - 2) If roadway has been dedicated to Manatee County, obtain Right-of-Way Use Permit and copy the Public Works Dept. Locations Section with proposed location drawing.
  - 3) Follow procedures in "Sunshine State One-Call", paying special attention to the requirements of Section VII.
- E. Should water or sewer lines be damaged during the bore pipe line or casing installation, the cost of any repairs and retesting will be paid for by the utility company that installed the bore. The actual clearance between a bored casing crossing a water or sewer pipe should not be less than 18 inches.

**END OF SECTION**  
**CLEANING AND DISINFECTING POTABLE WATER PIPE LINES**

**PART 1      GENERAL**

**1.01          SCOPE OF WORK**

**The Contractor shall furnish all labor, materials, equipment and incidentals required to clean and disinfect potable water pipe lines. This work is required to place all types of pipe into service as potable water lines.**

**1.02          CLEANING WATER MAINS**

**At the conclusion of the work, the Contractor shall thoroughly clean all of the new pipe lines by flushing with water or other means to remove all dirt, stones, pieces or wood or other material which may have entered during the construction period. If, after this cleaning, any obstructions remain, they shall be removed.**

**1.03          DISINFECTING POTABLE WATER PIPE LINES**

- A. All record drawing requirements must be submitted to the Owner/Engineer prior to starting the bacteriological testing of water lines.**
- B. Prior to being placed in service, all potable water pipe lines shall be chlorinated in accordance with AWWA 651, "Standard Procedure for Disinfecting Water Main". The procedure shall meet Health Department requirements. The location of the chlorination and sampling points shall be determined by the Engineer. Taps for chlorination and sampling shall be uncovered and backfilled by the Contractor as required.**

- C. The general procedure for chlorination shall be to flush all dirty or discolored water from the lines, then introduce chlorine in approved dosages through a tap at one end while water is being withdrawn at the other end of the line. The chlorine solution shall remain in the pipe line for 24 hours.**

**Water for flushing, filling and disinfecting the new lines must be obtained without contaminating existing pipe lines. Water obtained from existing pipe lines for this purpose shall pass through an approved backflow prevention device.**

- D. Following the chlorination period, all treated water shall be flushed from the lines at their extremities and replaced with water from the distribution system. Bacteriological sampling and analysis of the replacement water shall then be made by an approved laboratory or the Health Department in full accordance with the AWWA Manual C651. The line shall not be placed in service until the requirements of the State and County Public Health Department are met. Results of the bacteriological tests together with certified record drawings must be submitted to the Health Department (FDEP) within 30 days of the tests.**
- E. Special disinfecting procedures when approved by the County, may be used where the method outlined above is not practical.**





**END OF SECTION**  
**POLYVINYL CHLORIDE (PVC) PIPE (GRAVITY SEWER)**

**PART 1      GENERAL**

**1.01      SCOPE OF WORK**

- A.    The Contractor shall furnish all labor, equipment, materials, pipe and incidentals and shall construct gravity sewers, complete, as shown on the drawings and as herein specified.**
- B.    The work shall include furnishing, laying and testing gravity sewer pipe.**

**1.02      SUBMITTALS DURING CONSTRUCTION**

- A.    The Contractor shall submit prior to construction, Shop Drawings, Working Drawings and Samples for approval to the Engineer.**
- B.    The Contractor shall submit to the Engineer not less than fourteen (14) calendar days after the date of the Notice to Proceed, a list of materials to be furnished, the names of suppliers and an expected schedule of delivery of materials to the site.**
- C.    The Contractor shall furnish in duplicate to the Engineer sworn certificates that all tests and inspections required by the Specifications under which the pipe is manufactured have been satisfied.**

- D. The pipe manufacturer shall inspect all pipe joints for out-of-roundness and pipe ends for squareness. The Contractor shall furnish to the Engineer, a manufacturer's Notarized Affidavit stating all pipe meets the requirements of ASTM, ASCE, ANSI, the Contract Documents, as well as all applicable standards regarding the joint design with respect to square ends and out-of-round joint surfaces.**

**1.03 INSPECTION AND TESTS**

- A. All pipe and accessories shall be inspected and tested as required by the Standard Specifications to which the material is manufactured. The pipe shall be tested at the place of manufacture or taken to an independent laboratory by the manufacturer.**
- B. Each length of pipe shall be subject to inspection and approval at the factory, point of delivery and site of work. Sample of pipe to be tested shall be selected at random by the Engineer or the testing laboratory and shall be  
  
delivered by the Contractor to the testing laboratory approved by the Engineer.**
- C. When the specimens tested conform to applicable standards, all pipe represented by such specimens shall be considered acceptable based on the test parameters measured. Copies of test reports shall be submitted to the Engineer prior to the pipe installation. Acceptable pipe shall be stamped with an appropriate monogram under the supervision of the testing laboratory.**
- D. All pipe test specimens failing to meet the applicable standards shall be rejected. The Contractor may provide two additional test specimens from the same shipment or delivery for each failed specimen. The pipe shall be acceptable if both of these additional specimens meet the requirements of the applicable standards.**
- E. Pipe which has been deemed unacceptable by the Engineer shall be removed from the work site by the Contractor and shall be replaced with acceptable pipe.**

**PART 2 MATERIALS**

**2.01 GENERAL**

- A. The sizes of gravity sewer pipe shall be shown on the Drawings.**
- B. Each length of pipe shall bear the name or trademark of the**

manufacturer, the location of the manufacturing plant and the class or strength classification of the pipe. The markings shall be plainly visible on the pipe barrel.

## **2.02 POLYVINYL CHLORIDE (PVC) GRAVITY SEWER PIPE**

- A. PVC pipe, sizes 6" through 12", for use in non-pressure gravity sewer mains and laterals shall have an SDR of 26 and conform to ASTM D-3034. PVC pipe shall be made of PVC plastic, homogenous throughout and free from visible cracks, holes, foreign inclusions or other injurious defects. The pipe shall be uniform in color, density and other physical properties.**
- B. PVC pipe sizes over 12" shall be approved by Manatee County.**
- C. All pipe shall be in compliance with the above standard and be clearly marked as follows at intervals of 5 feet or less:
  - 1. Manufacturer's name or trademark.**
  - 2. Nominal pipe size.**
  - 3. PVC cell classification (eg. 12454-B).**
  - 4. The legend "Type PSM SDR-26 PVC Sewer Pipe" and the designation ASTM D-3034.****

In addition to the above mentioned requirements, all PVC sanitary sewer pipe shall be color coded green to conform with Manatee County Standards.

- D. PVC sewer fittings shall conform to the requirements of ASTM D-3034 and shall have an SDR of 26. Six inch PVC fittings for sewer laterals shall be SDR 26. Fittings shall be molded in one piece with elastomeric joints and minimum socket depths as measured in accordance with ASTM D-3034. Fittings not currently available in molded form may be fabricated in accordance with ASTM D-3034 with manufacturer's standard pipe bells and gaskets. Gasket shall have a minimum cross sectional area of 0.20 sq. in. and conform to ASTM F-477 specification.**

## **2.03 JOINTING PVC PIPE**

- A. The PVC joints shall be of the push-on type so that the pipe and fittings may be connected on the job without the use of solvent cement or any special equipment. The push-on joint shall be a single rubber gasket conforming to ASTM F-477, designed to be assembled by the positioning of a continuous molded rubber ring**

**gasket in an annular recess in the pipe of fitting socket and the forcing of the plain end of the entering pipe into the socket, thereby compressing the gasket radially to the pipe to form a positive seal. The gasket and annular recess shall be designed and shaped so that the gasket is locked in place against displacement as the joint is assembled. The rubber ring joint shall be designed for thermal expansion or contraction with a total temperature change of at least 75 degrees F in each joint per length of pipe. The bell shall consist of an integral wall section with a solid cross-section elastomeric ring which shall meet requirements of ASTM F-477. The thickened bell section shall be designed to be at least as strong as the pipe wall. Lubricant furnished for lubricating joints shall be nontoxic, shall not support the growth of bacteria, and shall have no deteriorating effects on the gasket or pipe material.**

- B. Wyes and riser fittings shall be gasketed connections. If female adapters SDR 26 or 35 are unavailable, solvent welds shall be acceptable upon approval by the Engineer.**
- C. Rubber doughnuts are not to be used.**

#### **2.04 JOINTS FOR DISSIMILAR PIPE**

**Joints between pipe of different materials shall be made using flanged connections. Metal piping shall not be threaded into plastic fittings, valves,**

**or couplings, nor shall plastic piping be threaded into metal valves, fittings, or couplings.**

#### **2.05 PIPE BEDDING AND PIPE COVER MATERIALS**

- A. Pipe bedding material shall be as specified in the Contract Documents.**
- B. Pipe cover material shall be equal to common fill as specified in the Contract Documents.**

- C. Pipe bedding and cover material for polyethylene coated ductile iron pipe fittings shall be well graded sand.

### **PART 3 EXECUTION**

#### **3.01 PIPE DISTRIBUTION**

The Contractor shall not distribute material on the job faster than it can be used to good advantage. He shall unload pipe which cannot be physically lifted by workers from the trucks, by a forklift, or other approved means. He shall not drop pipe of any size from the bed of the truck to the ground. He shall not distribute more than one weeks supply of material in advance of laying, unless otherwise approved by the Engineer.

#### **3.02 PIPE PREPARATION AND HANDLING**

- A. The Contractor shall inspect all pipe and fittings prior to lowering them into trench. Cracked, broken, or otherwise defective materials are not acceptable and shall not be used. The Contractor shall clean the ends of the pipe thoroughly. He shall remove foreign matter and dirt from inside of pipe and keep the pipe clean during and after laying.
- B. The Contractor shall use proper implements, tools and facilities for the safe and proper protection of the work. He shall lower the pipe into the trench in a manner to avoid any physical damage to the pipe, remove all damaged pipe from the job site and under no circumstances shall the pipe be dropped or dumped into trenches.

#### **3.03 LINE AND GRADE**

- A. The Contractor shall not deviate more than 1/2-inch for line and 1/4-inch for grade from the line design and design grade established by the Engineer provided that such variation does not result in a level or a reverse sloping invert. He shall measure the grade at the pipe invert and not at the top of the pipe. The Contractor shall furnish, set and control the line and grade by laser beam method. Other methods of controlling line and grade may be submitted to the Engineer for approval if using the laser beam method proves to be impractical because of other conditions.
- B. The Contractor shall drive a substantial stake on each side of the trench on a line at right angles to each stake of the primary line. A straight and even-edged 2-inch by 6-inch board shall be nailed or

clamped to the stakes in a level position and at an even foot height above the grade line of the proposed sewer. The centerline of the proposed sewer shall be located by measuring the primary line stake marking the board. No less than three lines and grade boards shall be set and immediately checked visually for errors in line and grade. As each additional board is placed, it shall be checked visually for error in line and grade. At least three boards shall be maintained at all times. During the laying of the pipe, a stout twill line shall be fastened to the boards at the center of alignment marks and pulled sufficiently tight to remove any noticeable or measurable sag. The line and grade of each pipe shall be obtained by measuring down from the string line by means of a plumbed grade pole.

- C. The Contractor shall use the laser beam method of maintaining line and grade. The Contractor shall submit evidence to the Engineer that a qualified operator shall handle the equipment during the course of construction. A "Caution-Laser Light" placard shall be displayed in a conspicuous place. When "in the pipe" method is used, grade boards shall be installed for the first 50 feet of pipe. The Contractor shall check the line and grade at any additional points at which offset stakes have been placed and when requested by the Engineer. A fan shall be provided to circulate the air if bending of the beam due to air temperature variations becomes apparent with "in the pipe" units. However excessive air velocity shall not be permitted to cause pulsating or vibrating of the beam. If, in the opinion of the Engineer, the beam cannot be accurately controlled, this method of setting line and grade shall be discontinued. When the above ground method is used, the set-up shall be checked with the three grade boards including one set at the upstream manhole. If the laser has a gradient indicator, two boards may be used to check the set-up. The grade board at the up-stream manhole shall be retained to check into as pipe laying progresses.

### 3.04

#### PREPARATION OF TRENCH

- A. The Contractor shall provide pipe bedding material under all the pipe for the full trench width. The minimum depth of bedding material below the pipe barrel shall be as follows:

**Pipe Size    Minimum Depth of Bedding Under Pipe Barrel**

15" & Smaller	4 inches
18" to 36"	6 inches
42" & Larger	9 inches

- B. The depth of pipe bedding material under the pipe bell shall not be

less than three inches under normal trench conditions.

- C. The Contractor shall hand-grade bedding to proper grade ahead of the pipe laying operation. The bedding shall provide a firm, unyielding support along the entire pipe length.
- D. Should the Contractor excavate the trench below the required depth for pipe bedding material placement without direction from the Engineer, the Contractor shall fill the excess depth with pipe bedding material as specified herein to the proper subgrade.
- E. The Contractor shall excavate bell holes at each joint to permit proper assembly and inspection of the entire joint.

### **3.05 DEWATERING**

The Contractor shall prevent water from entering the trench during excavation and pipe laying operations to properly grade the bottom of the trench and allow for proper compaction of the backfill. Pipe shall not be laid in water.

### **3.06 LAYING AND JOINTING PIPE AND FITTINGS**

- A. The Contractor shall lay pipe upgrade with spigot ends pointing in direction of flow. After a section of pipe has been lowered into the prepared trench, he shall clean the end of the pipe to be joined, the inside of the joint and, if applicable, the rubber ring immediately prior to joining the pipe. The Contractor shall assemble the joint in accordance with the recommendations of the manufacturer of the type of joint used. He shall provide all special tools and appliances required for the jointing assembly.
- B. The Contractor shall lay all pipe uniformly to line and grade so that the finished sewer shall present a uniform bore. Variations from line and grade in excess of the tolerances specified under **LINE AND GRADE** are not acceptable and the work shall be rejected.
- C. The Contractor shall check the pipe for alignment and grade after the joint has been made. The pipe bedding shall form a continuous and uniform bearing and support for the pipe barrel between joints. Sufficient pressure shall be applied to the joint to assure that the joint is "home" as defined in



the standard installation instructions provided by the pipe manufacturer. The Contractor shall place sufficient pipe cover material to secure the pipe from movement prior to installing the next joint to assure proper pipe alignment and joint makeup.

- D. Pipe 21" and smaller intended to be in straight alignment shall be laid so that the inside joint space does not exceed 3/8" in width. If interior joints on 24" and larger pipe laid either in straight alignment or on a curve are greater than 3/8", the Contractor shall thoroughly clean the joint surfaces and fill and seal the entire joint with premixed mortar conforming to ASTM C-387 only after the trench has been backfilled, unless otherwise approved by the Engineer. Trowel smooth on the inside surface. Water shall not be allowed to rise in or around, or pass over any joint before it has substantially set.
- E. When the Contractor lays pipe within a movable trench shield, he shall take all necessary precautions to prevent pipe joints from pulling apart when moving the shield ahead.
- F. The Contractor shall prevent excavated or other foreign material from getting into the pipe during the laying operation. He shall close and lock the open end of the last laid section of pipe to prevent entry of foreign material or creep of the gasketed joints when laying operations cease, at the close of the day's work, or whenever the workers are absent from the job.
- G. The Contractor shall plug or close off the pipes which are stubbed off with temporary plugs.
- H. The Contractor shall take all necessary precautions to prevent the "uplift" or floating of the line prior to the completion of the backfilling operation.
- I. The Contractor shall make connections of non-reinforced pipe to manholes or concrete structures, so that a standard pipe joint is located at a minimum of 18" outside the edge of structure.
- J. When field cutting and/or machining the pipe is necessary, the Contractor shall use only tools and methods recommended by the pipe manufacturer and approved by the Engineer.
- K. Service lateral shall be constructed by the Contractor as shown on the standard sewer details and located approximately as shown on the Contract Drawings.

**3.07 LAYING PLASTIC PIPE**

- A. Polyvinyl chloride (PVC) pipe shall be installed by the Contractor in accordance with the instructions of the manufacturer, as shown on the Drawings and as called out in the Contract Documents.**
- B. The Contractor shall lay the pipe, bedding and backfill to lines and grade shown on the Drawings and called out in the Contract Documents. Blocking under the pipe will not be permitted.**
- C. The Contractor shall install a green metallic tape as shown in these Standards below finish grade along the entire pipeline PVC sewer main pipe route.**
- D. The Contractor shall use care in the handling, storage and installation of pipe. Storage of pipe on the job site shall be done in accordance with the pipe manufacturer's recommendation.**

**3.08 BACKFILL IN THE PIPE ZONE**

- A. The pipe zone shall be considered to include the full width of the excavated trench from the bottom of the trench to a point above the top outside surface of the barrel of the pipe.**
- B. The Contractor shall pay particular attention to the area of the pipe zone from the flow line to the springline of the pipe to insure that firm support is obtained to prevent any lateral movement of the pipe during the final backfilling of the pipe zone.**
- C. The Contractor shall take care to insure that the pipe does not rest directly on the bell or pipe joint, but is uniformly supported on the barrel throughout its entire length.**
- D. After the pipe is laid by the Contractor to line and grade, he shall place and carefully compact pipe bedding material for the full width of the trench to the springline of the pipe. He shall place the material around the pipe in 6-inch layers and thoroughly hand tamp with approved tamping sticks supplemented by "walking in" and slicing with a shovel to assure that all voids are filled.**
- E. The Contractor shall backfill and carefully compact the area above the pipe springline with pipe cover material to a point 12" above the**

top outside surface of the pipe barrel. Pipe bedding material may, at the Contractor's option, be substituted for pipe cover material.

### **3.09 EXCESS TRENCH WIDTH**

- A. Normal trench widths shall be as shown on the Drawings. If the normal trench width below the top of the pipe is exceeded for any reason, the Contractor shall furnish an adequate support for the pipe. The Engineer may determine that the pipe being used is strong enough for the actual trench width or the Contractor may furnish a stronger pipe or a concrete cradle for approval.**
- B. Concrete thickness under the pipe shall be one-third of the nominal diameter of the pipe, but not less than four inches. Concrete block or brick may be used for adjusting and maintaining proper grade and elevation of pipe. After the pipe is laid to line and grade, the Contractor shall place 3,000 psi concrete under the pipe for the full width of the trench to form a cradle of the required length and thickness with the concrete brought up to a level equal to 1/4 of the inside pipe diameter below the springline of the pipe. Start and terminate the concrete cradle at the face of a pipe bell or collar. Do not encase pipe joints at the ends of the concrete cradle.**
- C. After the concrete has taken initial set, the Contractor shall place cover material over the concrete cradle and up to a level 12" above the pipe barrel and for the full width of the trench. Cover material shall be placed by hand or by equally careful means.**

### **3.10 CONNECTING DISSIMILAR PIPE MATERIALS**

The Contractor shall use the following method to connect dissimilar pipe materials. Use concrete closure collars only when approved by the Engineer and then only to make connections between dissimilar pipe when standard rubber gasketed joints or flexible couplings are impracticable. Before the closure collars are poured, wash the pipe to remove all loose material and soil from the surface on which the concrete will be placed. Wet nonmetallic pipe thoroughly prior to pouring the collars. Wrap and securely fasten a light gauge of sheet metal or building-felt around the pipe to insure that no concrete shall enter the line. Place reinforcement as shown on the plans. Make entire collar in one pour using 3,000 psi concrete and extend a minimum 12" on each side of the joint. The minimum thickness around the outside diameter of the pipe shall be 6". No collar shall be poured in water. After the collars are poured and have taken their initial set, cure by covering with well-moistened earth.

**3.11 PIPE BULKHEADS**

- A. Connections for future sewers shall be bulkheaded by the Contractor in the following manner:**
  - 1. All wyes and bell-and-spigot pipe sewers 18" in diameter or smaller shall be bulkheaded with caps or disc stoppers with factory-fabricated resilient joints. The disk or cap shall be banded or otherwise secured to withstand all test pressures without leakage.**
  - 2. Connections 21" and 24" in diameter shall be bulkheaded with a four-inch brick wall, using clay brick or concrete brick. The wall shall be capable of withstanding all test pressures without leakage.**
  - 3. Connections 27" in diameter and larger shall be bulkheaded with an eight-inch wall, using clay brick or concrete brick. The wall shall be capable of withstanding all test pressures without leakage.**

**3.12 AIR TEST FOR GRAVITY SEWERS - GENERAL**

- A. Gravity sewers shall be required to pass the low-pressure air test described herein.**
- B. Air loss rates may be measured by the Engineer. These tests shall be performed by the Contractor under the observation of the Engineer and County Inspector.**
- C. The groundwater height above the installed pipe shall be determined by attaching a transparent plastic tube to a pipe nipple in the manhole and using the plastic tube as a manometer. A test hole may be dug directly above the sewer main for visual inspection.**
- D. The ends of branches, laterals, tees, wyes and stubs included in a test section shall be plugged to prevent air leakage. All plugs shall be secured to prevent blowout due to internal pressure. A test section is defined as the length of sewer between manholes.**
- E. The Contractor shall repair all visible leaks in manholes and pipe, even if the leakage test requirements are met.**

**3.13 LAMP TEST FOR GRAVITY SEWER MAINS**

- A. Prior to testing, the Contractor shall prepare the lines for testing. All lines shall be thoroughly cleaned.**
- B. The Contractor shall furnish all equipment necessary for testing including, but not limited to, ladders, a lamping light and a vehicle to use as power source.**
- C. Gravity lines shall be lamped from both the upstream and downstream ends between the manholes.**
- D. A minimum image of 75 percent shall be acceptable.**
- E. Failure to meet the 75% image requirement shall result in the Contractor having to video tape the line at his own expense. The Engineer or his representative shall be present while the line is video taped. The tape shall be submitted to Manatee County for evaluation.**
- F. The Contractor shall relay or otherwise correct any line deemed unacceptable by the Engineer. This work shall be done entirely at the Contractor's expense.**
- G. Grouting of sewer lines or re-rounding machines are not approved corrective measures.**
- H. Sewer lines shall be re-lamped and may be required by Manatee County to be video taped again.**

**3.14 FINAL SEWER CLEANING**

- A. Prior to final acceptance and final manhole-to-manhole inspection of the sewer system by the Engineer, the Contractor shall flush and clean all parts of the system, remove all accumulated construction debris, rocks, gravel, sand, silt and other foreign material from the sewer system at or near the closest downstream manhole. If necessary, he shall use mechanical rodding or bucketing equipment.**
- B. During the final manhole-to-manhole inspection of the sewer system, the County may require the Contractor to reflush and clean any section or portion of the line if any foreign matter is still present in the system.**

**END OF SECTION**

**FIBERGLASS MANHOLES**

**PART 1 GENERAL**

**1.01 SCOPE OF WORK**

- A. The Contractor shall furnish all materials, labor and equipment and construct manholes consisting of fiberglass as shown on the Drawings and as specified herein.**
- B. Fiberglass reinforced polyester manholes shall be manufactured from commercial grade polyester or vinyl ester resin with fiberglass reinforcements. Manholes shall be a one piece unit manufactured to meet or exceed all specifications of A.S.T.M. D-3753, latest addition. Manholes shall be manufactured by an established national manufacturer exclusively producing FRP sanitary sewer manholes.**
- C. The manufacture, dimensions, material and construction methods**

shall be available for inspection and approved by the Engineer in advance of construction. The Engineer reserves the right to inspect the facilities of the supplier and the manufacturer if they are different.

- D. Intercept manholes shall be either free standing fiberglass or precast concrete with one piece fiberglass liner. Intercept manholes are defined as manholes with a force main discharging into them followed by gravity manholes to the lift station. They are further defined as other than straight through flow, such as tees or drop inlet. Manholes where turbulence and release of hydrogen sulfide gas is anticipated are also considered intercept manholes.

## **1.02 SUBMITTALS**

The Contractor shall submit shop drawings showing details of construction, reinforcing, joints, openings and all other specified details to the Owner/Engineer for review and approval.

## **1.03 INSPECTION**

- A. The quality of all materials, the process of manufacture and the finished sections shall be subject to inspection and approval by the Owner/Engineer or authorized representative of the Owner. Such inspection may be made at the place of manufacture, on site, or both locations. The fiberglass section may be inspected prior to unloading from the delivery truck and marked by the inspector showing acceptance or rejection. However, discovery of failure at any time to meet the requirements of these Specifications is cause for rejection.
- B. Sections rejected after delivery to the job shall be marked for identification and shall be removed from the job at once. All sections which are damaged after delivery as determined by the Engineer, shall be rejected. Sections already installed, shall be removed and replaced entirely at the Contractor's expense.
- C. At the time of inspection, the sections shall be examined for compliance with ASTM D-3753, latest revision, these Specifications and with the approved manufacturer's drawings. All sections shall be inspected for general appearance, dimension, blisters, cracks, roughness, soundness, etc. The surface shall be free of defect.
- D. Imperfections may be repaired subject to the approval of the Engineer and after demonstration by the manufacturer that strong and permanent repairs result.

**PART 2 PRODUCTS**

**2.01 FIBERGLASS MATERIALS**

**A. Resin**

The resins used shall be a commercial grade unsaturated polyester resin.

**B. Reinforcing Materials**

The reinforcing materials shall be commercial Grade "E" type glass in the form of continuous roving and chop roving, and shall have a coupling agent that will provide a suitable bond between the glass reinforcement and the resin.

**C. Interior Surfacing Material**

The inner surface exposed to the chemical environment shall be a resin-rich layer of 0.010 to 0.020" thick. The inner surface layer exposed to the corrosive environment shall be followed with a minimum of two passes of chopped roving of minimum length 0.5" (13 mm) to maximum length of 2.0" (50.8 mm) and shall be applied uniformly to an equivalent weight of 3 oz/ft<sup>2</sup>. Each pass of chopped roving shall be well-rolled prior to the application of additional reinforcement. The combined thickness of the inner surface and interior layer shall not be less than 0.10" (2.5 mm).



**D. Interior Surface**

The surface shall be free of crazing, delamination, blisters larger than 0.5" in diameter and wrinkles of 0.125" or greater in depth. Surface pits may be permitted if they are less than 0.75" in diameter and less than 0.0625" deep. Voids that may not be broken with finger pressure and that are entirely below the resin surface shall be permitted if they are less than 0.5" in diameter and less than 0.0625" thick.

**E. Wall Construction Procedure**

After inner layer has been applied, the manhole wall shall be constructed with chop and continuous strand filament wound manufacturing process which insures continuous reinforcement and uniform strength and composition. The cone section, if produced separately, shall be affixed to the barrel section at the factory with resin-glass reinforced joint resulting in a one piece unit. Seams shall be fibreglassed on the inside and the outside using the same glass-resin jointing procedure.

**F. Exterior Surface**

There shall be a UV inhibitor consisting of gray pigment added to the exterior resin coat for a minimum thickness .125" to prevent degradation during aboveground storage.

**G. Repairs**

All manhole repairs shall meet all requirements of the Contract Documents.

**H. Manhole Lengths**

Manhole lengths shall be measured in 6" increments +/- 2".

**I. Diameter Tolerance**

Tolerance of inside diameter shall be +/- 1% of required manhole diameter.

**J. Load Rating**

The complete manhole shall have a minimum dynamic-load rating of 16,000 lbs. when tested in accordance with A.S.T.M. D-3753. To establish this rating, the complete manhole shall not leak, crack, or suffer other damage when load tested to 40,000 lbs. and shall not deflect vertically downward more than 0.25 in. at the point of load application when loaded to 24,000 lb. This testing criteria shall not relieve the manufacturer of the responsibility for providing manholes that may sustain, without damage, all legal Florida wheel loads.

**K. Stiffness**

The manhole cylinder shall have the minimum pipe-stiffness values shown in table below when tested in accordance with A.S.T.M. D-3753 Table 1.

MANHOLE LENGTH IN FT.	F/ID <sup>3</sup> Y, PSI (k Pa)
3 - 6.5	0.72 ( 4.96)
7 - 12.5	1.26 ( 8.69)
13 - 20.5	2.01 (13.86)
21 - 25.5	3.02 (20.82)
26 - 35	5.24 (36.13)

**L. Soundness**

The Contractor shall insure that in order to determine soundness, the manufacturer shall apply an air or water pressure test to the manhole test sample. Test pressure shall be not less than 3 psig or greater than 5 psig. The manufacturer shall inspect the entire manhole for leaks while holding at the established pressure. Leakage through the laminate shall be cause for failure of the test. Refer to A.S.T.M. D-3753 8.6.

**M. Chemical Resistance**

Test in accordance with A.S.T.M. D-3753 8.7.

**N. Manhole Bottom**

Manholes may require resin fiber-reinforced bottoms. Bottom shall have a minimum of three 1-1/2" deep x 3-1/2" wide stiffening ribs completely enclosed with resin fiber-reinforcement and have a minimum 3" anti-flotation ring. Manhole bottom shall be a minimum of 5/16" thick and designed to resist all pressures induced by water, soil and wheel loads with a maximum deflection of 1/4".

O. Fillers and Additives

Fillers shall be inert to the environment and manhole construction. Sand shall not be an approved filler. Additives, such as thixotropic agents, catalysts, promoters, etc., may be added as required by the specific manufacturing process to be used to meet the requirements of the Contract Documents. The resulting reinforced-plastic material shall meet the requirements of the Contract Documents.

2.02 **MANHOLE FRAMES AND LIDS**

Manhole frames and lids shall meet ASTM A48, Specification for Gray Iron Castings, Class 30 or Grade 60-45-12 Ductile Iron meeting the requirements of ASTM A536, Specification of Ductile Iron Casting. Cast in a true symmetrical pattern of tough, dense and even grained iron, free from warping, scales, lumps, blisters, sandholes or any defects of any kind. Provide indented pattern lids with lettering as shown on the Drawings. Machine or grind frames and lids at touching surfaces to provide firm seats and prevent rocking. Remove and replace any set not matching perfectly. All frames and covers shall be designed to withstand an HS20 wheel loading as defined by AASHTO specifications.

2.03 **MANHOLE INSERTS**

All sanitary sewer manholes installed shall require watertight manhole inserts. Inserts shall be as manufactured by FRW Industries, Conroe, Texas or approved equal. Inserts shall be complete with a self-cleaning relief valve. Relief valve shall operate on a pressure differential of 1/2 psi. Neoprene gaskets shall be installed under the insert lip to insure a leakproof seal.

**PART 3 MANUFACTURE**

**3.01 MANUFACTURE OF FIBERGLASS MANHOLES**

A. Manhole cylinders, manway reducers, and connectors shall be manufactured from glass fiber-reinforced polyester or using a combination of chop and continuous filament wound process.

B. Interior Access

All installed manholes shall be designed so that they support a ladder or step system. All ladder or step systems shall be installed in accordance with the manufacturer's recommendations.

C. Manway Reducer

For 48" diameter manholes, manway reducers shall be concentric with respect to the larger portion of the manhole diameter. Larger manholes may have concentric or eccentric manway reducer openings.

D. Cover and Ring Support

A typical ring and cover plate shall be supported without damage to the manhole. Normal installation shall include 6" to 18" of concrete grade rings between fiberglass manhole and cover plate ring.

3.02 EXTERIOR SURFACE

The exterior surface shall be relatively smooth with no sharp projections. Hand-work finish may be acceptable if enough resin is present to eliminate fiber show. The exterior surface shall be free of blisters larger than 0.5" in diameter, delamination or fiber show. For manholes intended to be anchored into concrete bases, there shall be an antiflotation anchor ring or rings provided around the bottom of the fiberglass wall.

3.03 PHYSICAL PROPERTIES

		Hoop Direction	Axial Direction
a. Tensile Strength	(psi)	18,000	5,000
b. Tensile Modulus	(psi)	$0.6 \times 10^6$	$0.7 \times 10^6$
c. Flexural Strength	(psi)	26,000	4,500
d. Flexural Modulus	(psi)	$1.4 \times 10^6$	$0.7 \times 10^6$
e. Compressive Strength	(psi)	18,000	12,000

### **3.04 TEST METHODS**

All tests shall be performed as specified in A.S.T.M. D-3753 latest addition, Section 8. Test method D-790 and test method D-695.

### **3.05 QUALITY CONTROL**

Each manhole shall be tested and meet all required ASTM D-3753 designations for dimensional requirements, hardness, and workmanship. Test records shall be forwarded to the Owner/Engineer.

### **3.06 CERTIFICATION**

As a basis of acceptance, the manufacturer shall provide an independent certification consisting of a copy of the manufacturer's test reports along with a copy of the test results certifying that representative manhole samples have been tested, and inspected in accordance with the provisions of this Specification and meet all requirements of same.

### **3.07 SHIPPING AND HANDLING**

The Contractor shall not drop or impact the fiberglass manhole. An approved method of lifting the fiberglass manhole is by inserting a 4"x4"x30" timber into the top of manhole with cable attached or by a nylon sling or "choker" connection around center of manhole. Use of chains or cables in contact with the manhole surface is prohibited. The Contractor is advised that whatever method he chooses to install the manhole, it is his responsibility to handle and install it in a manner so as not to cause damage.

## **PART 4 CONCRETE**

### **A. Fiberglass Bottom**

The Contractor may use concrete to form the bench area and invert. Concrete also may be used on the top of anti-flotation ring and around the reducer section as required to resist buoyancy.

### **B. Concrete Bottom**

The Contractor shall lower the manhole into the wet concrete until it reaches the proper elevation. A minimum of 6" of fiberglass manhole shall be inserted into the wet concrete below flow line prior to making the manhole plumb. The concrete shall extend a minimum of one foot from the outside wall of the manhole and a minimum of 6" above influent lines. Concrete shall form the bench and invert area and rise a minimum of 4" above influent lines. Concrete may be required by the Owner/Engineer around the reducer section to resist buoyancy as well as other forces due to water and soil pressures. Concrete bases shall be at least 16" thick and properly reinforced to resist pull out of the fiberglass manhole.

C. Concrete Collar

Design of the concrete collars required to distribute traffic wheel loadings shall be included in the design of manholes. The design shall be signed and sealed by a Florida licensed Professional Engineer. This design shall also include any requirements for the support of the manhole lid and frame.

**PART 5 MANHOLE CONSTRUCTION**

**A. FIBERGLASS MANHOLE INSTALLATION**

The Contractor shall set fiberglass section vertical and in true alignment. All manholes shall meet the following installation tolerances:

The finished manhole shall not be out of plumb by more than 3/8" per 10 feet of height. For manholes exceeding 40'-0" high, the variation from plumb shall not exceed 1-1/2".

Any jog or offset of wall surface each side of a joint shall not exceed 1/2".

Variation in the joint width around the circumference of the manhole shall not exceed 3/8".

**B. GRADE ADJUSTMENT**

The Contractor shall set precast concrete grade rings on top of manhole slabs and precast concrete manhole cones to provide grade adjustment in setting manhole frames.

**C. BACKFILL**

Unless otherwise shown on the Drawings, sand, crushed stone, or pea gravel shall be used for backfill around the manhole for a minimum distance of one foot from the outside surface and extending from the bottom of the excavation to the top of the reducer section. Suitable material chosen from the excavation may be used for the remainder of the backfill. The material chosen shall be free of large lumps or clods, which will not readily break down under compaction. This material will be subject to approval by Engineer.

**D. BACKFILL PROCEDURE**

The Contractor shall place backfill in maximum layers of 12 inches loose measure and mechanically tamp to 95% Standard Proctor Density, unless otherwise approved by Engineer. Flooding shall not be permitted. Backfill shall be placed in such a manner as to prevent any wedging action against the fiberglass manhole structure.

**E. MARKING AND IDENTIFICATION**

Each manhole shall be marked on the inside and outside with the following information:

1. Manufacturer's name or trademark.
2. Manufacturer's factory location.
3. Manufacturer's serial number.
4. Total length.

**F. TESTING**

1. After constructed to its finished height and before being backfilled, each manhole shall be tested for water tightness.
  - a. Plug pipe lines and perform vacuum test. Observing all recommended safety measures induce a backpressure of 5.0 p.s.i. equivalent to 10" Hg (mercury). The manhole assembly is considered satisfactory if the vacuum loss is less than 1" Hg for the length of time listed in the following table:

Time of Test in Seconds	
Dept	Manhole Diameter Feet



<b>Feet</b>	<b>4</b>	<b>5</b>	<b>6</b>
-------------	----------	----------	----------

4

10  
13  
16

8

20  
26  
32

12

30  
39  
48

16

40  
52  
64

20

50  
65  
80

24

---

<u>60</u>	<u>78</u>	<u>96</u>
<u>T</u>		
<u>5</u>	<u>6.5</u>	<u>8</u>

**Note: Add "T" seconds for each additional 2'-0" of depth.**

- 2. Failure to pass this test requires the Contractor to correct the problems and retest. The Contractor will replace leaking gaskets and/or concrete sections and retest the completed manhole. No manhole will be accepted without successfully passing this test.**

**G. STUB LINES**

**The Contractor shall provide stub lines where shown on the Drawing or as directed by the Engineer for the connection of future sewer lines to manholes. Provide bell end enclosed with an approved plug at the end of each stub line. Bell of stub line shall be as close to manhole exterior surface as practical. The Contractor shall accurately reference each stubline for direction and record along with the actual invert elevation. He shall furnish the Engineer two copies of the above specified data on stub lines.**

**H. CONNECTION TO EXISTING MANHOLES**

**All piping entering existing manholes shall have resilient pipe to manhole seals per ASTM C-923.**

**END OF SECTION**  
**VALVES AND APPURTENANCES**

**PART 1      GENERAL**

**1.01        SCOPE OF WORK**

- A.    The Contractor shall furnish all labor, materials, equipment and incidentals required and install complete and ready for operation all valves and appurtenances as shown on the Drawings and as specified herein.**
  
- B.    All valves and appurtenances shall be of the size shown on the Drawings and, to the extent possible, all equipment of the same type on the Project shall be from one manufacturer.**
  
- C.    All valves and appurtenances shall have the name of the manufacturer and the working pressure for which they are designed cast in raised letters upon some appropriate part of the body.**
  
- D.    All valves shall have a factory applied, fusion bonded epoxy coating on interior and exterior.**
  
- E.    The equipment shall include, but not be limited to, the following:  
(The section numbers and pages are listed in parenthesis)**
  - 1.    Gate Valves (Sec. 2.01, pg. 58)**
  - 2.    Pressure Sustaining and Check Valves (Sec. 2.02, pg. 59)**
  - 3.    Ball Valves for PVC Pipe (Sec. 2.03, pg. 60)**
  - 4.    Butterfly Valves (Sec. 2.04, pg. 60)**
  - 5.    Plug Valves (Sec. 2.05, pg. 62)**
  - 6.    Valve Actuators (Sec. 2.06, pg. 62)**
  - 7.    Air Release Valves (Sec. 2.07, pg. 67)**
  - 8.    Valve Boxes (Sec. 2.08, pg. 67)**
  - 9.    Corporation Cocks (Sec. 2.09, pg. 68)**
  - 10.   Flange Adapter Couplings (Sec. 2.10, pg. 68)**
  - 11.   Flexible Couplings (Sec. 2.11, pg. 68)**
  - 12.   Hose Bibs (Sec. 2.12, pg. 69)**
  - 13.   Slow Closing Air and Vacuum Valves (Sec. 2.13, pg. 69)**
  - 14.   Surge Anticipator Valve (Sec. 2.14, pg. 70)**
  - 15.   Check Valves (Sec. 2.15, pg. 71)**

16. Hydrants (Sec. 2.16, pg. 71)
17. Restraining Clamps (Sec. 2.17, pg. 73)
18. Tapping Sleeves and Tapping Valves (Sec. 2.18, pg. 73)
19. Single Acting Altitude Valves (Sec. 2.19, pg. 73)

## **1.02 DESCRIPTION OF SYSTEMS**

All of the equipment and materials specified herein are intended to be standard for use in controlling the flow of potable water, reclaim water, wastewater, etc., depending on the applications.

## **1.03 QUALIFICATIONS**

All of the types of valves and appurtenances shall be products of well established reputable firms who are fully experienced and qualified in the manufacture of the particular equipment to be furnished. The equipment shall be designed, constructed and installed in accordance with the best practices and methods and shall comply with these Specifications as applicable. Valves shall be as covered under mechanical devices in Section 8 of ANSI/NSF Standard 61.

## **1.04 SUBMITTALS**

- A. Submit to the Engineer within 30 days after execution of the contract a list of materials to be furnished, the names of the suppliers and the date of delivery of materials to the site.
- B. Complete shop drawings of all valves and appurtenances shall be submitted to the Engineer for approval in accordance with the Specifications.

## **1.05 TOOLS**

Special tools, if required for normal operation and maintenance shall be supplied with the equipment.

## **PART 2 PRODUCTS**

### **2.01 GATE VALVES**

- A. All buried valves shall have cast or ductile iron three (3) piece valve boxes.

- B. Where indicated on the drawings or necessary due to locations, size, or inaccessibility, chain wheel operators shall be furnished with the valves. Such operators shall be designed with adequate strength for the valves with which they are supplied and provide for easy operation of the valve. Chains for valve operators shall be galvanized.**
- C. Where required, gate valves shall be provided with a box cast in a concrete slab and a box cover. Length of box shall include slab thickness. Box cover opening shall be for valve stem and nut. Valve wrenches and extension stems shall be provided by the manufacturer to actuate the valves. The floor box and cover shall be equal to those manufactured by Rodney Hunt Machine Company, Orange, Massachusetts, Clow, DeZurik or approved equal.**
- D. Gate valves with 3"-20" diameters shall be resilient seated, manufactured to meet or exceed the requirements of AWWA C509 and UL/FM of latest revision and in accordance with the following specifications. Valves shall have an unobstructed waterway equal to or greater than the full nominal diameter of the valve.**
- E. The valves shall have a non-rising stem of stainless steel or of cast, forged, or rolled bronze as shown in AWWA C509. Stem seals shall be provided and shall be of the O-ring type, two above and one below the thrust collar.**
- F. The sealing mechanism shall consist of a cast iron gate fully encapsulated with an EPDM Elastomer coating. The Elastomer type shall be permanently indicated on the disc or body of the valve. The resilient sealing mechanism shall provide zero leakage at the water working pressure when installed with the line flow in either direction.**
- G. The valve body, bonnet, and bonnet cover shall meet or exceed all the requirements of AWWA C509 latest edition. All ferrous surfaces inside and outside shall have a fusion-bonded epoxy coating. Wrench nut shall be provided for operating the valve.**
- H. Valves shall be suitable for an operating pressure of 200 psi and shall be tested in accordance with AWWA C509.**
- I. All bonnet bolts, nuts and studs shall be stainless steel.**

## **2.02**

### **PRESSURE SUSTAINING AND CHECK VALVE**

- A. Pressure sustaining and check valve shall be pilot operated diaphragm actuated valve with cast iron body, bronze trim, and 125-**

**pound flanged ends. The valve shall be hydraulically operated, diaphragm type globe valve. The main valve shall have a single removable seat and a resilient disc, of rectangular cross section, surrounded on three and a half sides. The stainless steel stem shall be fully guided at both ends by a bearing in the valve cover, and an integral bearing in the valve seat. It shall be sleeved at both ends with delrin. No external packing glands are permitted and there shall be no pistons operating the main valve or any controls. The valve shall be equipped with isolation cocks to service the pilot system while permitting flow if necessary. Main valve and all pilot controls shall be manufactured in the United States of America. Valve shall be single chamber type, with seat cut to 5 degrees taper.**

- B. Valve shall maintain a minimum (adjustable) upstream pressure to a preset (adjustable) maximum. The pilot system shall consist of two direct acting, adjustable, spring loaded diaphragm valves.**
- C. Valve shall be cast iron (ASTM A48) with main valve trim of brass (QQB-B-626) and bronze (ASTM B61). The pilot control valves shall be cast brass (ASTM B62) with 303 stainless steel trim. Valve shall be similar in all respects to CLA-VAL Company, Model 692G-01ABKG, as manufactured by CLA-VAL Company, Winter Park, Florida, or similar pressure sustaining and check valve as manufactured by Golden Alderson; or approved equal.**

### **2.03 BALL VALVES FOR PVC PIPE**

- A. Ball valves for PVC pipe shall be of PVC Type 1 with union, socket, threaded or flanged ends as required. Ball valves shall be full port, full flow, all plastic construction, 150 psi rated with teflon seat seals and T-handles. PVC ball valves shall be as manufactured by Celanese Piping Systems, Inc., Wallace and Tiernan, Inc., Plastiline, Inc., or approved equal.**
- B. All valves shall be mounted in such a position that valve position indicators are plainly visible when standing on the floor.**

### **2.04 BUTTERFLY VALVES**

- A. Butterfly valves shall conform to the AWWA Standard Specifications for Rubber Seated Butterfly Valves, Designated C504, except as hereinafter specified. Valves, except as specified hereinafter, shall be Class 150A or B, except that valves furnished downstream of the high service pumps shall be Class 250 and equal to those manufactured by Henry Pratt Company, DeZurik, Kennedy, or approved equal. The valve discs shall be constructed of cast iron conforming to ASTM A-48, Class 40, ASTM A-126, Class B or ductile iron conforming to ASTM A536, Grade 65-45-12 for Class 150 or less. Ductile iron conforming to ASTM A536, Grade 65-45-12 shall be provided for all Class 250 valves. All valves shall be leak tested at 200 psi.**
- B. The face-to-face dimensions of flanged end valves shall be in accordance with Table 2 of above mentioned AWWA Specification for short-body valve. Adequate two-way thrust bearings shall be provided. Flange drilling shall be in accordance with ANSI B16.1.**
- C. Valve seats shall be an EPDM elastomer. Valve seats 24 inches and larger shall be field adjustable and replaceable without dismounting operator disc or shaft and without removing the valve from the line. All retaining segments and adjusting devices shall be of corrosion resistant material with stainless Nylock screws and be capable of the 1/8-inch adjustment. Valves 20 inches and smaller shall have bonded or mechanically restrained seats as outlined in AWWA C 504. Where the EPDM seat is mounted on the valve body, the mating edge of the valve disc shall be 18-8 stainless steel or Nickel-Chrome, 80-20%. Where the EPDM seat is mounted on the valve disc, the valve body shall be fitted with an 18-8 stainless steel seat offset from the shaft, mechanically restrained and covering 360 degrees of the peripheral opening or seating surface.**
- D. The valve body shall be constructed of ductile iron or close grain cast iron per ASTM A126, Class B with integrally cast hubs for shaft bearing housings of the through boss-type. Butterfly valves of the "wafer" or "spool" type will not be accepted.**
- E. The valve shaft shall be turned, ground, and polished constructed of 18-8, ASTM A-276, Type 304 stainless steel and designed for both torsional and shearing stresses when the valve is operated under its greatest dynamic or seating torque. Shaft shall be of either a one piece unit extending full size through the valve disc and valve bearing or it may be of a stub shaft design. Shaft bearings shall be teflon or nylon, self-lubricated type.**

- F. All valves shall be subject to hydrostatic and leakage tests at the point of manufacture. The hydrostatic test for Class 250 valves shall be performed with an internal hydrostatic pressure equal to 500 psi applied to the inside of the valve body of each valve for a period of five minutes. During the hydrostatic test, there shall be no leakage through the metal, the end joints or the valve shaft seal. The leakage test for the Class 250 valves shall be performed at a differential pressure of 230 psi and against both sides of the valve. No adjustment of the valve disc shall be necessary after pressure test for normal operation of valve. The Class 150 valves shall be tested in conformance with AWWA C-504.**
- G. In general, the butterfly valve operators shall conform to the requirements of Section 3.8 of the AWWA Standard Specifications for Rubber Seated Butterfly Valves, Designation C504, insofar as applicable, and as herein specified.**
- H. Gearing for the operators shall be totally enclosed in a gear case in accordance with paragraph 3.8.3 of the above mentioned AWWA Standard Specification.**
- I. Operators shall be capable of seating and unseating the disc against the full design pressure of velocity, as specified for each class, into a dry system downstream and shall transmit a minimum torque to the valve. Operators shall be rigidly attached to the valve body.**
- J. The manufacturer shall certify that the required tests on the various materials and on the completed valves have been satisfactory and that the valves conform with all requirements of this Specification and the AWWA standard.**
- K. Where indicated on the Drawings, extension stems, floor stands, couplings, stem guides, and floor boxes as required shall be furnished and installed.**

## **2.05**

### **PLUG VALVES**

- A. Plug valves shall be eccentric plug valves capable of sustaining 150 psi in either direction without leaking.**

**Exception: Single direction plug valves may be used if it is clearly demonstrated they will never be required to resist pressure in both directions either in service or during pipe line testing.**



- B. Plug valves shall be tested in accordance with current AWWA Standard C-504-80 Section 5. Each valve shall be performance tested in accordance with paragraph 5.2 and shall be given a leakage test and hydrostatic test as described in paragraphs 5.3 and 5.4. The manufacturer shall furnish certified copies of reports covering proof of design testing as described in Section 5.5.**
- C. Plug valves shall be of the non-lubricated eccentric type with resilient faced plugs and shall be furnished with end connections as shown on the Plans. Flanged valves shall be faced and drilled to the ANSI 150 lb. standard. Mechanical joint ends shall be to the AWWA Standard C111-72. Bell ends shall be to the AWWA Standard C100-55 Class B. Screwed ends shall be to the NPT standard.**
- D. Plug valve bodies shall be of ASTM A126 Class B Semi-steel, 31,000 psi tensile strength minimum in compliance with AWWA Standard C507-73, Section 5.1 and AWWA Standard C504-70 Section 6.4. Port areas for valves 20-inches and smaller shall be 80 percent of full pipe area. Valves 24 inch and larger shall have a minimum port area of between 80 and 100 percent of full nominal pipe area. All exposed nuts, bolts, springs, washers, etc. shall be zinc or cadmium plated. Resilient plug facings shall be of Hycar or Neoprene.**
- E. Plug valves shall be furnished with permanently lubricated stainless steel or oil-impregnated bronze upper and lower plug stem bushings. These bearings shall comply with current AWWA Standards.**

## **2.06 VALVE ACTUATORS**

- A. General**
  - 1. All valve actuators shall conform to Section 3.8 of the AWWA Standard Specification and shall be either manual or motor operated.**
  - 2. Actuators shall be capable of seating and unseating the disc against the full design pressure and velocity, as specified for each class, into a dry system downstream, and shall transmit a minimum torque to the valve. Actuators shall be rigidly attached to the valve body.**
  - 3. Butterfly valve actuators shall conform to the requirements of Section 3.8 of the AWWA Standard specifications for Rubber Seated Butterfly Valves, Designated C504, insofar as applicable and as herein specified.**

## **B. Manual Actuators**

- 1. Manual actuators shall have permanently lubricated, totally enclosed gearing with handwheel and gear ratio sized on the basis of actual line pressure and velocities. Actuators shall be equipped with handwheel, position indicator, and mechanical stop-limiting locking devices to prevent over travel of the disc in the open and closed positions. They shall turn counter-clockwise to open valves. Manual actuators shall be of the traveling nut, self-locking type and shall be designed to hold the valve in any intermediate position between fully open and fully closed without creeping or fluttering. Actuators shall be fully enclosed and designed to produce the specified torque with a maximum pull of 80 pounds on the handwheel or chainwheel. Actuator components shall withstand an input of 450 foot pounds for 30" and smaller and 300 foot pounds for larger than 30" size valves at extreme actuator positions without damage. Valves located above grade shall have handwheel and position indicator, and valves located below grade shall be equipped with a two inch (2") square AWWA operating nut located at ground level and cast iron extension type valve box. Valve actuators shall conform to AWWA C504, latest revision.**

## **C. Motor Actuators (Modulating)**

- 1. The motor actuated valve controller shall include the motor, actuator unit gearing, limit switch gearing, limit switches, position transmitter which shall transmit a 4-20 mA DC signal, control power transformer, electronic controller which will position the valve based on a remote 4-20 milliamp signal, torque switches, bored and key-wayed drive sleeve for non-rising stem valves, declutch lever and auxiliary handwheel as a self-contained unit.**

- 2. The motor shall be specifically designed for valve actuator service using 480 volt, 60 Hertz, three phase power as shown, on the electrical drawings. The motor shall be sized to provide an output torque and shall be the totally enclosed, non-ventilated type. The power gearing shall consist of helical gears fabricated from heat treated alloy steel forming the first stage of reduction. The second reduction stage shall be a single stage worm gear. The worm shall be of alloy steel with carburized threads hardened and ground for high efficiency. The worm gear shall be of high tensile strength bronze with hobbled teeth. All power gearing shall be grease lubricated. Ball or roller bearings shall be used throughout. Preference will be given to units having a minimum number of gears and moving parts. Spur gear reduction shall be provided as required.**
- 3. Limit switches and gearing shall be an integral part of the valve control. The limit switch gearing shall be made of bronze and shall be grease lubricated, intermittent type and totally enclosed to prevent dirt and foreign matter from entering the gear train. Limit switches shall be of the adjustable type capable of being adjusted to trip at any point between fully opened valve and fully closed valve.**
- 4. The speed of the actuator shall be the responsibility of the system supplier with regard to hydraulic requirements and response compatibility with other components within the control loop. Each valve controller shall be provided with a minimum of two rotor type gear limit switches, one for opening and one for closing. The rotor type gear limit switch shall have two normally open and two normally closed contacts per rotor. Gear limit switches must be geared to the driving mechanism and in step at all times whether in motor or manual operation. Provision shall be made for two additional rotors as described above, each to have two normally open and two normally closed contacts. Each valve controller shall be equipped with a double torque switch. The torque switch shall be adjustable and will be responsive to load encountered in either direction of travel. It shall operate during the complete cycle without auxiliary relays or devices to protect the valve, should excessive load be met by obstructions in either direction of travel. The torque switch shall be provided with double-pole contacts.**
- 5. A permanently mounted handwheel shall be provided for manual operation. The handwheel shall not rotate during**

electric operations, but must be responsive to manual operation at all times except when being electrically operated. The motor shall not rotate during hand operation nor shall a fused motor prevent manual operation. When in manual operating position, the unit will remain in this position until motor is energized at which time the valve operator will automatically return to electric operation and shall remain in motor position until handwheel operation is desired. This movement from motor operation to handwheel operation shall be accomplished by a positive declutching lever which will disengage the motor and motor gearing mechanically, but not electrically. Hand operation must be reasonably fast. It shall be impossible to place the unit in manual operation when the motor is running. The gear limit switches and torque switches shall be housed in a single easily accessible compartment integral with the power compartment of the valve control. All wiring shall be accessible through this compartment. Stepping motor drives will not be acceptable.

6. The motor with its control module must be capable of continuously modulating over its entire range without interruption by heat protection devices. The system, including the operator and control module must be able to function, without override protection of any kind, down to zero dead zone.
7. All units shall have strip heaters in both the motor and limit switch compartments.
8. The actuator shall be equipped with open-stop-close push buttons, an auto-manual selector switch, and indicating lights, all mounted on the actuator or on a separate locally mounted power control station.
9. The electronics for the electric operator shall be protected against temporary submergence.
10. Actuators shall be Limitorque L120 with Modutronic Control System containing a position transmitter with a 4-20MA output signal or equal.

**D. Motor Actuators (Open-Close)**

1. The electronic motor-driven valve actuator shall include the motor, actuator gearing, limit switch gearing, limit switches, torque switches, fully machined drive sleeve, declutch lever,

**and auxiliary handwheel as a self-contained unit.**

- 2. The motor shall be specifically designed for valve actuator service and shall be of high torque totally enclosed, nonventilated construction, with motor leads brought into the limit switch compartment without having external piping or conduit box.**

- (a) **The motor shall be of sufficient size to open or close the valve against maximum differential pressure when voltage to motor terminals is 10% above or below nominal voltage.**
  - (b) **The motor shall be prelubricated and all bearings shall be of the anti-friction type.**
- 3. **The power gearing shall consist of helical gears fabricated from heat treated steel and worm gearing. The worm shall be carburized and hardened alloy steel with the threads ground after heat treating. The worm gear shall be of alloy bronze accurately cut with a hobbing machine. All power gearing shall be grease lubricated. Ball or roller bearings shall be used throughout.**
- 4. **Limit switches and gearing shall be an integral part of the valve actuator. The switches shall be of the adjustable rotor type capable of being adjusted to trip at any point between fully opened valve and fully closed valve. Each valve controller shall be provided with a minimum of two rotor type gear limit switches, one for opening and one for closing (influent valves require additional contacts to allow stopping at an intermediate position). The rotor type gear limit switch shall have two normally open and two normally closed contacts per toro. Additional switches shall be provided if shown on the control and/or instrumentation diagrams. Limit switches shall be geared to the driving mechanism and in step at all times whether in motor or manual operation. Each valve actuator shall be equipped with a double torque switch. The torque switch shall be adjustable and will be responsive to load encountered in either direction of travel. It shall operate during the complete cycle without auxiliary relays or devices to protect the valve should excessive load be met by obstructions in either direction of travel. Travel and thrusts shall be independent of wear in valve disc or seat rings.**

5. **A permanently mounted handwheel shall be provided for manual operation. The handwheel shall not rotate during electric operation except when being electrically operated. The motor shall not rotate during hand operation, nor shall a fused motor prevent manual operation. When in manual operating position, the unit will remain in this position until motor is energized at which time the valve actuator will automatically return to electric operation and shall remain in motor position until handwheel operation is desired. Movement from motor operation to handwheel operation shall be accomplished by a positive declutching lever which will disengage the motor and motor gearing mechanically, but not electrically. Hand operation must be reasonably fast. It shall be impossible to place the unit in manual operation when the motor is running.**
6. **Valve actuators shall be equipped with an integral reversing controller and three phase overload relays, Open-Stop-Close push buttons, local-remote-manual selector switch, control circuit transformer, three-phase thermal overload relays and two pilot lights in a NEMA 4X enclosure. In addition to the above, a close coupled air circuit breaker or disconnect switch shall be mounted and wired to the valve input power terminals for the purpose of disconnecting all underground phase conductors.**
7. **The valve actuator shall be capable of being controlled locally or remotely via a selector switch integral with the actuator. In addition, an auxiliary dry contact shall be provided for remote position feedback.**
8. **Valve A.C. motors shall be designed for operation on a 480 volt, 3-phase service. Valve control circuit shall operate from a fuse protected 120 volt power supply.**
9. **Motor operators shall be as manufactured by Limitorque Corporation, Type L120 or approved equal.**

## **2.07**

### **AIR RELEASE VALVES**

**The air release valves for use in water or force mains shall be installed as shown on the Drawings. The valves shall have a cast iron body cover and baffle, stainless steel float, bronze water diffuser, Buna-N or Viton seat, and stainless steel trim. The fittings shall be threaded. The air release valves shall be Model 200A or 400A as manufactured by APCO Valve and Primer Corporation, Schaumburg, Illinois, or approved equal.**

**2.08**

**VALVE BOXES**



- A. Buried valves shall have cast-iron three piece valve boxes or HDPE adjustable valve boxes. Cast iron valve boxes shall be provided with suitable heavy bonnets and shall extend to such elevation at or slightly above the finished grade surface as directed by the Engineer. The barrel shall be two-piece, screw type, having a 5 1/4-inch shaft. The upper section shall have a flange at the bottom with sufficient bearing area to prevent settling and shall be complete with cast iron covers. Covers shall have "WATER", "SEWER", or "RECLAIM", as applicable, cast into the top.**
- B. All valves shall have actuating nuts extended to within four (4) feet of the top of the valve box. All valve extensions will have a centering guide plate two (2) inches maximum below the actuating nut. The valve extension shall be fastened to the existing nut with a set screw. Valve boxes shall be provided with a concrete base and a valve nameplate engraved with lettering 1/8-inch deep as shown on the Drawings.**
- C. HDPE adjustable valve boxes shall be one complete assembled unit composed of the valve box and extension stem. All moving parts of the extension stem shall be enclosed in a housing to prevent contact with the soil. Valve box assembly shall be adjustable to accommodate variable trench depths.**
- D. The entire assembly shall be made of heavy wall high density polyethylene. All exterior components shall be joined with stainless steel screws. The valve box top section shall be adaptable to fit inside a valve box upper section.**
- E. The stem assembly shall be of a telescoping design that allows for variable adjustment length. The stem material shall be of plated steel square tubing. The stem assembly shall have a built-in device that keeps the stem assembly from disengaging at its fully extended length. The extension stem must be torque tested to 1000 foot pounds. Covers shall have "WATER", "SEWER" or "RECLAIMED" clearly and permanently impressed into the top surface.**

## **2.09**

### **CORPORATION COCKS**

**Corporation cocks for connections to cast-iron, ductile iron or steel piping shall be all brass or bronze suitable for 180 psi operating pressure and similar to Mueller Co. H-10046 or approved equal by Clow Corp., and shall be of sizes required and/or noted on the Drawings.**

**2.10**

**FLANGE ADAPTER COUPLINGS**

**Flange adapter couplings shall be of the size and pressure rating required for each installation and shall be suitable for use on either cast iron or ductile iron pipe. They shall be similar or approved equal to Dresser Company, Style 128. All couplings shall have a sufficient number of factory installed anchor studs to meet or exceed a minimum test pressure rating of 230 psi minimum.**

## **2.11 FLEXIBLE COUPLINGS**

**Flexible couplings shall be either the split type or the sleeve type as shown on the Drawings.**

- 1. Split type coupling shall be used with all interior piping and with exterior pipings noted on the Drawings. The couplings shall be mechanical type for radius groove piping. The couplings shall mechanically engage and lock grooved pipe ends in a positive couple and allow for angular deflection and contracting and expansion.**
- 2. Couplings shall consist of malleable iron, ASTM Specification A47, Grade 32510 housing clamps in two or more parts, a single chlorinated butyl composition sealing gasket with a "C" shaped cross-section and internal sealing lips projecting diagonally inward, and two or more oval track head type bolts with hexagonal heavy nuts conforming to ASTM Specification A 183 and A194 to assemble the housing clamps. Bolts and nuts shall be hot dipped galvanized after fabrication.**
- 3. Victaulic type couplings and fittings may be used in lieu of flanged joints. Pipes shall be radius grooved as specified for use with the Victaulic couplings. Flanged adapter connections at fittings, valves, and equipment shall be Victaulic Vic Flange Style 741, equal by Gustin-Bacon Group, Division of Certain-Teed Products, Kansas City, Kansas, or approved equal.**
- 4. Sleeve type couplings shall be used with all buried piping. The couplings shall be of steel and shall be Dresser Style 38 or 40, as shown on the Drawings, or equal. The coupling shall be provided with hot dipped galvanized steel bolts and nuts unless indicated otherwise.**
- 5. All couplings shall be furnished with the pipe stop removed.**

6. **Couplings shall be provided with gaskets of a composition suitable for exposure to the liquid within the pipe.**
7. **If the Contractor decides to use victaulic couplings in lieu of flanged joints, he shall be responsible for supplying supports for the joints.**

## **2.12 HOSE BIBS**

**Hose bibs shall be 3/4" or 1" brass, polished chromium plated brass, with vacuum breaker as noted on the drawings.**

## **2.13 SLOW CLOSING AIR AND VACUUM VALVES**

- A. **The Contractor shall furnish and install slow closing air and vacuum valves as shown on the Drawings which shall have two (2) independent valves bolted together. The air and vacuum valve shall have all stainless steel float, guided on both ends with stainless shafts. The air and vacuum valve seat shall be Buna-N to insure drop tight closure. The Buna-N seat shall be fastened to the cover stainless shoulder screws in a manner to prevent distortion of the seat. The float shall be guided at both ends with stainless steel bushings.**
- B. **The valve cover shall have a male lip designed to fit into the body register for accurate alignment of the float into the Buna-N seat. The valve cover shall have 250-pound class flanged outlet connection.**
- C. **The surge check valve shall be bolted to the inlet of the air and vacuum valve and consist of a body, seat, disc, and compression spring. A surge check unit shall operate on the interphase between the kinetic energy and relative velocity flows of air and water, so that after air passes through, and water rushes into the surge check, the disc starts to close, reducing the rate of flow of water into the air valve by means of throttling orifices in the disc to prevent water hammer in the air valves. The surge check orifices must be adjustable type for regulation in the field to suit operating conditions. Valve shall be rated for 250-pound class working pressure.**
- D. **The complete slow closing air and vacuum valve with air release valve shall have been flow tested in the field, substantiated with test data to show reduction of surge pressure in the valve. Flow test data shall be submitted with initial shop drawings for approval.**

- E. Valve exterior to be painted Red Oxide, Phenolic TT-P86, Primer or approved equal for high resistance to corrosion.
- F. All materials of construction shall be certified in writing to conform to ASTM specifications as follows:

Air Valve Cover, Body, and Surge Check Body      Cast Iron    ASTM A48, Class 30

Float      Stainless Steel    ASTM A240

Surge Check Seat and Disc      Stainless Steel    ASTM A582

Air Valve Seat      Buna-N

Spring      Stainless Steel    T302

**2.14      SURGE ANTICIPATOR VALVES**

- A. Surge anticipator valves shall be furnished for the pumping systems as shown on the Drawings. The valve shall be hydraulically operated, pilot controlled, and diaphragm or piston actuated. The main valve shall be cast iron conforming to ASTM A48 with bronze trim conforming to ASTM B61 and flanged ends conforming to ANSI B161.1. The main valve shall be globe type with a single removable seat and a resilient disc.
- B. The diaphragm actuated valve shall have a stainless steel stem guided at both ends by a bearing in the valve cover and an integral bearing surface in the seat. No external packing glands shall be permitted. The valve shall be fully serviceable without removing it from the line. The pilot system shall be of noncorrosive construction and provided with isolation cocks.
- C. The piston actuated valve shall operate on the differential piston principle. The valve piston shall be guided on its outside diameter. The valve shall be able to operate in any position and shall be fully serviceable without removing it from the line. The pilot system shall be provided with isolation cocks, and be of noncorrosive materials of construction.

- D. The valve shall be designed specifically to minimize the effects of water hammer, resulting from power failure at the pumping station, or from normal stopping and starting of pumping operators. The valve shall open hydraulically on a down surge, or low pressure wave created when the pump stops, remain open during the low pressure cycle in order to be open when the high pressure wave returns. The high pressure pilot shall be adjustable over a 20 to 200 psi range and the low pressure pilot shall be adjustable over a 15 to 75 psi range. The valve shall be the 250 Class.

## 2.15 CHECK VALVES

- A. Check valves for cast iron and ductile iron pipe lines shall be swing type and shall meet the material requirements of AWWA Specification C508. The valves shall be iron body, bronze mounted, single disc, 175 psi working water pressure and nonshock. Valves shall be as manufactured by Mueller, Clow, American, Kennedy, M&H, or approved equal.
- B. When there is no flow through the line, the disc shall hang lightly against its seat in practically a vertical position. When open, the disc shall swing clear of the waterway.
- C. Check valves shall have bronze seat and body rings, extended bronze hinge pins and bronze nuts on the bolts of bolted covers.
- D. Valves shall be so constructed that disc and body seat may easily be removed and replaced without removing the valve from the line. Valves shall be fitted with an extended hinge arm with outside lever and weight. Weights provided and approved by the Engineer shall be installed.

## 2.16 HYDRANTS

Hydrants shall be AVK Series 27 DRX Barrel (nostalgic style with stainless steel bolts) Kennedy Type K-81, American Darling B-84-B or Mueller Super Centurian A423 or approved equal, and shall conform to the "Standard Specification for Fire Hydrants for Ordinary Water Works Service", AWWA C502 and UL/FM certified, and shall in addition meet the specific requirements and exceptions which follow:

1. Hydrants shall be according to manufacturer's standard pattern and of standard size, and shall have one 4-1/2" steamer nozzle and two 2-1/2" hose nozzles.

- 2. Hydrant inlet connections shall have mechanical joints for 6" ductile-iron pipe.**
- 3. Hydrant valve opening shall have an area at least equal to that area of a 5-1/4" minimum diameter circle and be obstructed only by the valve rod. Each hydrant shall be able to deliver 500 gallons minimum through its two 2-1/2" hose nozzles when opened together with a loss of not more than 2 psi in the hydrants.**
- 4. Each hydrant shall be designed for installation in a trench that will provide 5-ft. cover.**
- 5. Hydrants shall be hydrostatically tested as specified in AWWA C502.**
- 6. Hydrants shall be rated at 200 psi.**
- 7. All nozzle threads shall be American National Standard.**
- 8. Each nozzle cap shall be provided with a Buna N rubber washer.**
- 9. Hydrants shall be so arranged that the direction of outlets may be turned 90 degrees without interference with the drip mechanism and without the mechanism obstructing the discharge from any outlet.**
- 10. Hydrants must be capable of being extended without removing any operating parts.**
- 11. Hydrants shall have bronze-to-bronze seatings as per AWWA C502-85.**
- 12. Hydrant main valve closure shall be of the compression type opening against the pressure and closing with the pressure. The resilient seat material shall meet the requirements of AWWA C-509 and shall preferably be EPDM Elastomer.**
- 13. Internal and below ground iron parts (bonnet, nozzle section and base) shall have a fusion bonded epoxy coating per AWWA C550. Aboveground external hydrant parts (cap, bonnet and nozzle section) shall be either epoxy coated together with a UV resistant polyester coating or have two shop coats of paint per AWWA C502. The lower stand pipe or barrel shall be protected with asphaltic coatings per AWWA C502.**

14. Exterior nuts, bolts and washers shall be stainless steel. Bronze nuts may be used below grade.
15. All internal operating parts shall be removable without requiring excavation.

## 2.17 RESTRAINING CLAMPS

Restraining clamp assemblies as detailed in the drawings for use at hydrant connections to water mains, or at fittings where shown on the Drawings, shall be as manufactured by American Cast Iron Pipe, Star Pipe Products, U.S. Pipe, or approved equal.

## 2.18 TAPPING SLEEVES AND GATE VALVES

- A. Tapping valves shall meet the requirement of AWWA C500. The valves shall be flanged, shall be mechanical joint outlet with nonrising stem, designed for vertical burial and shall open left or counterclockwise. Stuffing boxes shall be the "O-ring" type. Operating nut shall be AWWA Standard 2" square for valves 2" and up. The valves shall be provided with an overload seat to permit the use of full size cutters. Gaskets shall cover the entire area of flange surfaces and shall be supplied with EPDM wedges up to 30" diameter.
- B. Tapping sleeves and saddles shall seal to the pipe by the use of a confined "O" ring gasket, and shall be able to withstand a pressure test of 180 psi for one hour with no leakage in accordance with AWWA C110, latest edition. A stainless steel 3/4" NPT test plug shall be provided for pressure testing. All bolts joining the two halves shall be stainless steel and shall be included with the sleeve or saddle. Sleeves and saddles shall be protected from corrosion by being fusion applied epoxy coated, or be made of 18-8 Type 304 stainless steel. Saddle straps shall be 18-8 Type 304 stainless steel.

## 2.19 SINGLE ACTING ALTITUDE VALVES

- A. Function



1. The altitude control valve shall be of the single acting type, closing off tightly when the water reaches the maximum predetermined level in the tank to prevent overflow; and opening to permit replenishing of the tank supply when the water level drops approximately 6" to 12" below the maximum level.
2. A hand operated valve in the power water line to the top of the piston shall permit adjustment of the speed of valve closing. The tank water level control shall be by means of a diaphragm operated, spring loaded, three way pilot which directs power water to or from the top of the main valve piston. The three way pilot shall be of bronze construction. The diaphragm surface exposed to the tank head shall be not less than 57 sq. inches. It shall be possible to adjust the spring  
  
above the diaphragm for water level control approximately 20% above or below the factory setting.

#### **B. Description**

1. The main valve shall operate on the differential piston principle such that the area on the underside of the piston is no less than the pipe area on the upper surface of the piston is of a greater area than the underside of the piston.
2. The valve piston shall be guided on its outside diameter by long stroke stationary Vee ports which shall be downstream of the seating surface to minimize the consequences of throttling. Throttling shall be done by the valve Vee ports and not the valve seating surfaces.
3. The valve shall be capable of operating in any position and shall incorporate only one flanged cover at the valve top from which all internal parts shall be accessible. There shall be no stems, stem guides, or spokes within the waterway. There shall be no springs to assist the valve operation.

#### **C. Construction**

1. The valve body shall be of cast iron ASTM A-126 with flanges conforming to the latest ANSI Standards. The valve shall be extra heavy construction throughout. The valve interior trim shall be bronze B-62 as well as the main valve operation.
2. The valve seals shall be easily renewable while no diaphragm shall be permitted within the main valve body.
3. All controls and piping shall be of non-corrosive construction.
4. A visual valve position indicator shall be provided for observing the valve piston position at any time.

**D. Figure Number**

The valves shall be the 20" Globe type (Fig. 3200-D) as manufactured by GA Industries of Mars, Pennsylvania, or approved equal.

**PART 3 EXECUTION**

**3.01 INSTALLATION**

- A. All valves and appurtenances shall be installed in the location shown, true to alignment and rigidly supported. Any damage occurring to the above items before they are installed shall be repaired to the satisfaction of the Engineer.
- B. After installation, all valves and appurtenances shall be tested at least two hours at the working pressure corresponding to the class of pipe, unless a different test pressure is specified. If any joint proves to be defective, it shall be repaired to the satisfaction of the Engineer.
- C. Install all floor boxes, brackets, extension rods, guides, the various types of operators and appurtenances as shown on the Drawings that are in masonry floors or walls, and install concrete inserts for hangers and supports as soon as forms are erected and before concrete is poured. Before setting these items, the Contractor shall check all plans and figures which have a direct bearing on their location and he shall be responsible for the proper location of these valves and appurtenances during the construction of the structures.
- D. Pipe for use with flexible couplings shall have plain ends as specified in the respective pipe sections.
- E. Flanged joints shall be made with high strength, low alloy Corten bolts, nuts and washers. Mechanical joints shall be made with mild corrosion resistant alloy steel bolts and nuts. All exposed bolts shall

be painted the same color as the pipe. All buried bolts and nuts shall be heavily coated with two (2) coats of bituminous paint comparable to Inertol No. 66 Special Heavy.

- F. Prior to assembly of split couplings, the grooves as well as other parts shall be thoroughly cleaned. The ends of the pipes and outside of the gaskets shall be moderately coated with petroleum jelly, cup grease, soft soap or graphite paste, and the gasket shall be slipped over one pipe end. After the other pipe has been brought to the correct position, the gasket shall be centered properly over the pipe ends with the lips against the pipes. The housing sections then shall be placed. After the bolts have been inserted, the nuts shall be tightened until the housing sections are firmly in contact, metal-to-metal, without excessive bolt tension.
- G. Prior to the installation of sleeve-type couplings, the pipe ends shall be cleaned thoroughly for a distance of 8". Soapy water may be used as a gasket lubricant. A follower and gasket, in that order, shall be slipped over each pipe to a distance of about 6" from the end.
- H. Valve boxes with concrete bases shall be installed as shown on the Drawings. Mechanical joints shall be made in the standard manner. Valve stems shall be vertical in all cases. Place cast iron box over each stem with base bearing on compacted fill and the top flush with final grade. Boxes shall have sufficient bracing to maintain alignment during backfilling. Knobs on cover shall be parallel to pipe. Remove any sand or undesirable fill from valve box.

### 3.02

#### HYDRANTS

- A. Hydrants shall be set at the locations designated by the Engineer and/or as shown on the Drawings and shall be bedded on a firm foundation. A drainage pit on crushed stone as shown on the Drawings shall be filled with gravel or crushed stone and satisfactorily compacted. During backfilling, additional gravel or crushed stone shall be brought up around and 6" over the drain port. Each hydrant shall be set in true vertical alignment and shall be properly braced. Concrete thrust blocks shall be placed between the back of the hydrant inlet and undisturbed soil at the end of the trench. Minimum bearing area shall be as shown on the plans. Felt paper shall be placed around the hydrant elbow prior to placing concrete. **CARE MUST BE TAKEN TO INSURE THAT CONCRETE DOES NOT PLUG THE DRAIN PORTS.** Concrete used for backing shall be as specified herein.
- B. When installations are made under pressure, the flow of water

through the existing main shall be maintained at all times. The diameter of the tap shall be a minimum of 2" less than the inside diameter of the branch line.

- C. The entire operation shall be conducted by workmen thoroughly experienced in the installation of tapping sleeves and valves, and under the supervision of qualified personnel furnished by the manufacturer. The tapping machine shall be furnished by the Contractor if tap is larger than 12" in diameter.
- D. The Contractor shall determine the locations of the existing main to be tapped to confirm the fact that the proposed position for the tapping sleeve will be satisfactory and no interference will be encountered such as the occurrence of existing utilities or of a joint or fitting at the location proposed for the connection. No tap will be made closer than 30" from a pipe joint.
- E. Tapping valves shall be set in vertical position and be supplied with a 2" square operating nut for valves 2" and larger. The valve shall be provided with an oversized seat to permit the use of full sized cutters.
- F. Tapping sleeves and valves with boxes shall be set vertically or horizontally as indicated on the Drawings and shall be squarely centered on the main to be tapped. Adequate support shall be provided under the sleeve and valve during the tapping operation. Sleeves shall be no closer than 30" from water main joints. Thrust blocks shall be provided behind all tapping sleeves. Proper tamping of supporting earth around and under the valve and sleeve is mandatory. After completing the tap, the valve shall be flushed to ensure that the valve seat is clean.

### **3.03 SHOP PAINTING**

Ferrous surfaces of valves and appurtenances shall receive a coating of rust-inhibitive primer. All pipe connection openings shall be capped to prevent the entry of foreign matter prior to installation.

### **3.04 FIELD PAINTING**

All metal valves and appurtenances specified herein and exposed to view shall be painted.

### **3.05 INSPECTION AND TESTING**

Completed pipe shall be subjected to hydrostatic pressure test for two hours at 180 psi. All leaks shall be repaired and lines retested as approved by the Engineer. Prior to testing, the pipe lines shall be

**supported in an approved manner to prevent movement during tests.**

**END OF SECTION**  
**PRECAST CONCRETE MANHOLES AND WETWELLS**

**PART 1 GENERAL**

**1.01 SCOPE OF WORK**

- A. The Contractor shall furnish all materials, labor and equipment and construct manholes consisting of precast sections as shown on the Drawings and as specified herein.**
- B. The manholes shall have an invert channel shaped to correspond with the lower half of the pipe. The top of the shelf shall be sloped to drain toward the flowing channel. Every effort shall be made by the Contractor to construct watertight structures. Structures that are not watertight or do not meet the requirements of ASTM C-433 are unacceptable.**
- C. The forms, dimensions, concrete and construction methods shall be available for inspection by the Engineer in advance of construction. The Engineer shall reserve the right to inspect the facilities of the manufacturer.**
- D. Flexible gasket connectors for connecting pipes shall meet the requirements of ASTM C-443 or latest revision, and are required in all manholes.**
- E. Lifting devices shall not penetrate the walls of the manholes.**

**1.02 SUBMITTALS**

**Submit to the Engineer, as provided in the General Conditions, shop drawings showing details of construction, reinforcing, joints, openings and all other specified details.**

**1.03 INSPECTION**

- A. The quality of all materials, the process of manufacture and the finished sections shall be subject to inspection and approval by the Engineer or other representative of the Owner. Such inspection may be made at the place of manufacture, and/or at the site. Wherever possible, the precast sections shall be inspected prior to unloading from the delivery truck and marked by the inspector showing acceptance or rejection. However, discovery at any time of failure to meet requirements of these Specifications is cause for rejection.**

- B. Sections rejected after delivery to the job shall be marked for identification and shall be removed from the job at once. All sections which are damaged after delivery will be rejected and if already installed, shall be acceptably**

**repaired, if permitted, or removed and replaced entirely at the Contractor's expense, as determined by the Engineer.**

- C. All sections shall meet the manufacturing tolerance requirements of ASTM C-478 or the following casting tolerances, whichever are more severe:**

<b>Wall Thickness</b>	<b><math>\pm 3/8"</math></b>
<b>Inside Diameter</b>	<b><math>\pm 3/8"</math></b>
<b>Outside Diameter</b>	<b><math>\pm 1/2"</math></b>
<b>Height or Length</b>	<b><math>\pm 3/8"</math></b>

- D. Pipe openings shall meet the recommended tolerances of the individual manufactured pipe to manhole connectors; however, the horizontal location shall be within  $\pm 2$  degrees of arc of that detailed on shop drawings.**
- E. At the time of inspection, the sections will be carefully examined for compliance with ASTM C478 latest revision, these Specifications and with the approved manufacturer's drawings. All sections shall be inspected for general appearance, dimension, "scratch-strength", blisters, cracks, roughness, soundness, etc. The surface shall be dense and close-textured.**
- F. Imperfections may be repaired subject to the approval of Manatee County Public Works Department after demonstration by the manufacturer that strong and permanent repairs result. Repairs shall be carefully inspected before final approval. Cement mortar used for repairs shall have a minimum compressive strength of 4,000 psi at 7 days and 5,000 psi at 28 days. Epoxy mortar may be utilized for repairs subject to the approval of the Engineer.**

## **PART 2 PRODUCTS**

### **2.01 PRECAST CONCRETE SECTIONS**

#### **A. GENERAL**

- 1. Except as modified in the Specifications, manholes shall meet the requirement of ASTM C478, or most recent revision, Specification for Precast Reinforced Concrete Manhole Sections. Cement shall meet the requirements of ASTM C150-80, or most recent revision, Specification for Portland Cement, Type II. Concrete shall have a compressive strength of 4,000 psi. Minimum wall thickness for manholes shall be 8" or 1/12 the inside manhole diameter, whichever is greater. Sections shall be custom made with openings to meet indicated pipe alignment conditions and invert elevations. Contractor shall submit shop drawings, consisting of manufacturer's standard details of various sections for approval prior to manufacture. Drawings of individual manholes showing invert elevations, pipe sizes and similar details are required. Manufacturer shall submit concrete mix designs together with certified test results for the Engineer's review prior to commencing manufacture.**
  
- 2. Manufacturer shall make a minimum of four standard test cylinders for each 100 cubic yards of concrete (or part thereof) that is cast each day. These test cylinders, along with sections cast that day, shall be marked in such a way that the test results can be matched with the appropriate castings. Two cylinders shall be cured with the product until the forms are stripped. At this time, one cylinder shall be broken to ascertain that a minimum strength of 2000 psi has been reached prior to moving the product from the forming location. The remaining two cylinders shall be cured and tested in accordance with ASTM C192-81 and C39-84. The average compressive strength for each day's production shall be greater than 4000 psi with no more than 10% of the tested cylinders falling below 4000 psi. In no case shall any cylinder strength fall below 3500 psi. All cylinder strengths shall be certified by a Florida Licensed Professional Engineer. Failure to meet these requirements for any day's production is cause for rejection of all sections cast that day.**

## **B. JOINTS**

- 1. Form joint contact surfaces with machined castings. Surfaces shall be parallel and the tongue equipped with a proper recess for the installation of a rubber gasket. Gaskets shall meet the requirements of Specifications for Joint for Circular Concrete Sewer and Culvert Pipe, Using Rubber Gaskets (ASTM C-443). In addition to this rubber gasket joint, the installation contractor may, at his own choice, add an exterior seal such**



as "Waterstop Rx", "Adeka Ultra Seal" or "Cadilloc Sealing Bands".

**C. PRECAST CONCRETE GRADE ADJUSTMENT**

- 1. Precast grade rings shall be used for final grade adjustment. No mortar shall be used which has begun to set. The grade rings used on manholes with fiberglass linings shall also be protected in the same manner.**

**D. INVERT CONSTRUCTION**

- 1. Inverts: Use precast preformed inverts from the manufacturer constructed specifically for each manhole or form with Type II cement and sand mortar and brick to provide a smooth flowing channel of similar shape and size of the sewer to which it connects.**
- 2. Junction Manholes: All inverts shall drop a minimum of 1" from the grade of pipes entering the manhole. Provide a true curve of the largest radius possible for changes in direction of sewer and entering branch or branches.**

**F. FIBERGLASS MANHOLES AND CONCRETE MANHOLES WITH PROTECTIVE LINERS.**

- 1. Manholes receiving flow from upstream lift stations, drop manholes, manholes with opposing flow, manholes receiving force mains and the first gravity manhole downstream of manholes receiving a force main including top and bottom sections, shall have a protective plastic liner or be free standing fiberglass. Manhole liners shall be manufactured of the listed materials, or approved equal:**

**5mm Fiberglass Reinforced Plastic (FRP) GU Liner  
3mm High Density Polyethylene (HDPE) Agru Liner  
2.5mm Polyvinyl Chloride (PVC) Dura-Plate Liner  
2mm Polypropylene Random Copolymer (PP-R) Agru  
Liner**

- 2. Lined manholes shall have 7" minimum concrete wall thickness. Unlined manholes shall have a minimum concrete wall thickness of 8".**

3. The approved liner may be in lengths and nominal inside diameters corresponding to the precast concrete wetwell or manhole precast sections. Thickness and reinforcement shall be adequate to resist pressures from 30'-0" depth of water between concrete and liner, handling stresses, vertical and horizontal movement due to temperature changes, drying shrinkage of the concrete and/or uneven settlement of the manhole.
4. The prefabricated wetwell or manhole liner shall be a non-load bearing component installed and adequately anchored inside a new precast concrete wetwell or manhole riser during the concrete casting process at the concrete precaster's manufacturing facility. The liner must be fully supported during the casting process.
5. The liners shall be resistant to the chemical environment normally found in the gravity wastewater transmission systems to which they will be exposed.
6. The liner shall have a warranty against defect in material and workmanship for a period of three years.
7. After assembly and installation, in the field, all internal seams are to be sealed per the manufacturer's standard method and details.

103

**G. FIELD INSTALLED FIBERGLASS MANHOLE LINERS**

1. Fiberglass Reinforced Plastic (FRP) manholes shall be one-piece construction FRP plain end cylinder pipe with an integral corbel design. Manhole liner diameter shall fit into the existing manhole such that a minimum 2-1/2" annular space is available for grouting. The Contractor shall measure the existing manhole prior to construction and shall be responsible for the liner fit. The Contractor shall submit factory certification for fiberglass liners. The reducer cone shall have a modified hemispherical shape with at least a 3" high FRP reinforcement collar and a 4" minimum width flat surface to support adjustment bricks/rings for a cast iron ring and cover. The cylinder pipe-to-reducer cone joint shall be factory-installed. No vertical seams or joints shall be allowed.
2. FRP manholes shall be fabricated from premium grade isophthalic polyester resin, fiberglass chopped strand, woven roving and continuous reinforcements. Sand filler shall not be

**permitted in the FRP laminate.**

- 3. FRP manholes shall be designed and fabricated in accordance with ASTM D3753, Standard Specification for Glass Fiber-Reinforced Polyester Manholes. FRP laminate shall conform to ASTM C582 and Chemical Resistance Tests shall conform to ASTM C581. FRP manholes shall be chemically resistant to normal domestic sanitary sewer environments as well as corrosive soil, groundwater and sea water environments. Manholes shall be designed to withstand a 16,000 pound vertical dynamic wheel load (AASHTO H-20 loading).**
- 4. FRP manholes shall be manufactured by an established national manufacturer with at least five years experience in producing FRP sanitary sewer manholes.**
- 5. All liners delivered to the job site shall be inspected for the following prior to installation:**

  - a. Inside surfaces of each section shall be free of bulges, dents, ridges, and other defects that result in a variation of the inside diameter of more than 1/8".**
  - b. The interior and exterior surfaces of the liner shall be completely free from pinholes, cracks, pits, or defects which is detrimental to the intended use of product. No liner will be installed which has apparent holes or openings which will permit the passage of liquid or gases through the liner wall.**
  - c. Factory repairs shall not be permitted.**
  - d. On site repairs shall not be permitted.**
- 6. The FRP liners shall be fabricated from fiberglass reinforced polyester or vinyl ester resins resistant to the chemical environment normally found in the gravity wastewater transmission systems to which they will be exposed.**
- 7. The FRP liner shall have a warranty against defect in material and workmanship for a period of three years.**

8. **After assembly and installation, in the field, all internal seams are to be sealed with material similar to the FRP used on the sections.**
9. **The annular space between liner and precast concrete with manhole shall be grouted with a pumpable concrete mix with a minimum 28 day strength of 3000 psi.**

#### **H. MANHOLE FRAMES AND LIDS**

**ASTM A48-74, or most recent revision, Specification for Gray Iron Castings, Class 30 or Grade 60-45-10 Ductile Iron meeting the requirements of ASTM A536-72, or most recent revision, Specification for Ductile Iron Castings. Cast in a true symmetrical pattern of tough, dense and even grained iron, free from warping, scales, lumps, blisters, sandholes, or any defects of any kind. Provide indented pattern lids with lettering as shown on the Drawings. Machine or grind frames and lids at touching surfaces to provide firm seats and prevent rocking. Remove and replace any set not matching perfectly. All frames and covers shall be designed to withstand an HS20-44 wheel loading as defined by AASHTO specifications.**

#### **I. MANHOLE INSERTS**

**Watertight manhole inserts shall be required for all sanitary sewer manholes installed. Inserts shall be as manufactured by FRW Industries, Conroe, Texas, or approved equal. Inserts shall be complete with a self-cleaning relief valve. Relief valves shall operate on a pressure differential of 1/2 psi. Neoprene gaskets shall be installed under the insert lip to insure a leakproof seal.**

#### **J. LATERALS**

##### **1. SERVICE CONNECTIONS**

**Install types of connections shown on the Drawings or as directed by the Engineer. Each service connection location shall be accurately recorded by station and offset method and referenced from the center of the downstream manhole. The Contractor shall furnish two copies of this record to the Engineer.**

## **2. SERVICE ASSEMBLY**

Provide wye branch, 6" curve pipe and clean-out pad as shown on the drawings. If the service line is not installed at the time of main construction, the opening shall be securely closed with an approved plug.

## **PART 3 MANHOLE CONSTRUCTION**

### **3.01 PRECAST CONCRETE MANHOLE INSTALLATION**

Precast concrete sections shall be set vertical and in true alignment. Rubber gaskets shall be installed in the previously set sections. All manholes shall meet the following installation tolerances:

1. The finished manholes shall not be out of plumb by more than 3/8" per 10 feet of height. For manholes exceeding 40'-0" high, the variation from plumb shall not exceed 1-1/2".
2. Any jog or offset of wall surface each side of a joint shall not exceed 1/2".
3. Variation in the joint width around the circumference of the manhole shall not exceed 1/4".
4. Lifting holes in the concrete sections required for handling or other purposes shall be plugged with a non-shrink grout or by grout in combination with concrete plugs.

### **3.02 GRADE ADJUSTMENT**

HDPE adjustment rings or precast concrete grade rings shall be set on top of manhole slabs and precast concrete manhole cones to provide grade adjustment in setting manhole frames.

### **3.03 SETTING MANHOLE FRAMES**

Manhole frames and lids shall be set to conform accurately to the finished ground or pavement grade as shown on the Drawings or as directed by the Engineer. Frames on manholes shall be set concentric with the adjusting rings and sealed so that the space between the top of the rings and the bottom flanges of the frame will be made watertight. A ring of mortar shall be placed around the outside of the bottom flange at least one inch thick and pitched to shed water away from the frame. Mortar shall be extended to the outer edge of the masonry and finished smooth and flush with the top of the flange.

**3.04 TESTING**

**A. After constructed to its finished height and before being backfilled, each manhole shall be tested for water tightness.**

- 1. Plug pipe lines and perform vacuum test. Observing all recommended safety measures induce a backpressure of 5.0 p.s.i. equivalent to 10" Hg (mercury). The manhole assembly is considered satisfactory if the vacuum loss is less than 1" Hg for the length of time listed in the following table:**

<b>Time of Test in Seconds</b>			
--------------------------------	--	--	--

<b>Dept</b>	<b>Manhole Diameter Feet</b>		
<b>Feet</b>	<b>4</b>	<b>5</b>	<b>6</b>

4

10  
13  
16

8

20  
26  
32

12

30  
39  
48

16

40  
52  
64



20

50

65

80

<hr/>		
24		
<hr/>		
60	78	96
<hr/>		
T		
<hr/>		
5	6.5	8
<hr/>		

Note: Add "T" seconds for each additional 2'-0" of depth.

- B. Failure to pass this test requires the Contractor to correct the problems and retest. The Contractor will replace leaking gaskets and/or concrete sections and retest the completed manhole. No manhole will be accepted without successfully passing this test.

### 3.05

#### STUB LINES

The Contractor shall provide stub lines where shown on the Drawing or as directed by the Engineer for the connection of future sewer lines to manholes. Provide bell end enclosed with an approved plug at the end of each stub line. Bell of stub line shall be as close to manhole exterior surface as practical. The Contractor shall accurately reference each stubline for direction and record along with the actual invert elevation. He shall furnish the Engineer two copies of the above specified data on stub lines.

### 3.06

#### CONNECTION TO EXISTING MANHOLES

The Contractor shall connect, where shown on the Drawings or directed by the Engineer, new lines into existing manholes. Unless existing stubs of correct size and location are found to exist, he shall remove a portion of the manhole wall masonry. All piping entering existing manhole shall be accomplished by mechanical rotary core boring the manhole riser. After installation of piping, the annular space between piping and concrete shall be sealed with resilient

**pipe to manhole seals meeting the requirements of ASTM C-923.**

**END OF SECTION**

**LIFT STATION SPECIFICATION**

**PART 1 GENERAL**

**The Contractor shall furnish all labor, materials, equipment and incidentals required to install complete automatic, underground lift station with all required equipment installed in a concrete pump chamber and adjacent concrete valve vault. The principal items of**

equipment shall include two submersible motor-driven sewage pumps, valves, internal piping, automatic pumping level controls, control panel and telemetry. All materials shall be new, without defects and of the best quality. All materials furnished and all work done shall be in strict accordance with the National Electrical Code and all local requirements and codes.

**1.01 STRUCTURES AND EQUIPMENT**

**A. Lift Station Wetwell**

All wetwells and lift stations shall be free standing fiberglass or precast concrete with a protective liner designed to accommodate the full developmental flow from all contributing areas at peak flow. The wetwell shall have a minimum of four (4) feet from the lowest invert to the wetwell bottom. The lift station wetwell size shall be determined using the following formula to determine the minimum volume between the off-level elevation and the influent invert elevation.

$$\text{MIN. VOLUME (GALS.)} = \text{PUMP CAPACITY (G.P.M.)} \times 4$$

Wetwell diameters shall be six (6) feet or larger. Four foot and five foot diameter wetwells shall be used only for special applications as approved by the Manatee County Public Works Department. The minimum wetwell wall thicknesses are as follows:

<u>DIAMETER</u> <u>THICKNESS</u>	<u>WALL THICKNESS</u>	<u>DIAMETER</u>	<u>WALL</u>
4' - 0"	7"	8' - 0"	8"
5' - 0"	7"	10' - 0"	10"
6' - 0"	7"	12' - 0"	12"

**B. Valve Vault**

A precast valve vault for three R.S. gate valves, two weighted lever-type swing check valves, and service hook-up shall be constructed adjacent to the wetwell. The valve vault shall have a two (2) inch PVC drain with a P-trap return to the wetwell. The service shall be equipped with a gate valve and 4" or 6" male aluminum quick-coupler and cap. The valve vault shall be of adequate size to allow a minimum 12" clearance between all flange fittings and any concrete surfaces. All valves shall have factory applied, fusion bonded epoxy coating on interior and exterior.

**C. Entrance Hatches**

The lift station top and entrance hatch shall be set a minimum of 8" above the 25-year flood plain, but not lower than 4" above the 100-year flood plain where applicable. The lift station wetwell and valve pit shall be equipped with an aluminum access cover of adequate size to permit easy removal and installation of sewage pumps and equipment. The wetwell access cover shall be a minimum 30" x 48" single or double door. The valve pit access cover shall be a minimum 48" x 48" double door. All access covers shall be constructed of aluminum with a minimum load rating of 150 lbs/sq. ft. and equipped with stainless steel hinges, hasp, neoprene gaskets to prevent water intrusion and a device to lock the doors in an open position when the lid is raised (Bilco, Halliday, or approved equal).

#### **D. Sewage Pumps**

Each lift station shall have two totally submersible sewage pumps with 230v, 3-phase, 60hz, Class F insulation, NEMA B design motors equipped with heat sensors to automatically shut off the motor in case of excessive heat build-up. Pumps shall be capable of pumping raw unscreened sewage, and able to pass a minimum 3" solid. All pumps shall have an enclosed impeller and shall be equipped with a bronze wear ring. The pump stator housing, and volute casing shall be constructed of cast iron. All pumps shall be equipped with "SO" type power cables and type 316 stainless steel lifting chains. Pumps less than 10 h.p. shall be equipped with a 1/4" lifting chain and pumps 10 h.p. or greater shall be equipped with a 3/8" lifting chain or as required by the pump's weight. All lifting chains shall be attached to the pump lifting bail using stainless steel shackles. All pump mounting systems shall be of the front loading slide rail type for ease of installation and removal of the sewage pumps. All pump discharge flanges shall have a standard ANSI bolt pattern. All rails and mounting hardware shall be stainless steel.

#### **E. Riser and Fittings**

Three inch and smaller Schedule 80 PVC riser pipe in 4'-0" diameter wetwells with operating pressures less than 40 psi may use solvent weld fittings. All PVC pipe installed shall be straight with no excessive bows or discoloration caused by exposure to sunlight. All PVC fittings shall be installed using the proper procedures, primer, high solids Sch. 80 PVC glue, and the correct size applicator as recommended by the fitting manufacturer for the size and type

of fitting being installed. All vertical piping shall be installed plumb and all horizontal piping shall be installed level.

For pressures higher than 40 psi, 3" diameter and smaller pipe shall have threaded fittings. Four inch through 8" diameter riser pipe shall be C-900, pressure Class 150 green PVC, with C-907 PVC pressure fittings or Schedule 80 PVC pipe with 150 psi Schedule 80 Van Stone style fittings. PVC pressure fittings used with C-900 pipe shall be restrained using Star Products 1100 Series or Uniflange 1300 Series restraint rings with factory applied fusion bonded epoxy coating and xylan coated Corten bolts. All C-900 connections to flanged fittings requiring restraints shall be made using EBBA Iron Series 2100 Megaflange-flange adapters. Non-restraint connections may use standard flange coupling adapters.

All flanged fittings in the wetwell and valve vault shall be connected using stainless steel nuts, bolts, flat washers and lock washers.

All stainless steel fasteners shall be treated with never-seize prior to assembly and torque according to the fitting manufacturer's recommendation. The bands around the piping shall be constructed from 2 inch x 1/4 inch stainless steel flat stock, shaped to fit the piping and sized to grip the piping without deforming the pipe when bolted to the braces.

All penetrations of structures for discharge piping shall use PVC sleeves and Link Seals with stainless steel hardware.

#### **F. Hardware**

A stainless steel hanger shall be installed in each wetwell for supporting floatball and pump cables. The hanger shall be constructed of 1/4" x 2" type 316 stainless steel flat stock with individual hooks for each floatball and pump cable constructed of 1/4" type 316 stainless steel rod stock. All fasteners, brackets, and other hardware installed in the wetwell and valve vault shall be type 316 stainless steel.

#### **G. Painting**

All paint and other coatings shall be applied in accordance with the product manufacturer's specifications for the surfaces being coated. The exterior of the wetwell structure and valve vault shall be coated with at least two (2) coats of a coal tar epoxy coating containing 78% volume of solids. The minimum thickness of each coat when dry shall be 8 mils. All iron body valves and fittings inside the valve vault and wetwell shall have a factory applied fusion bonded epoxy coating inside and outside.

## 2.01

## ELECTRICAL

### A. Service and Metering

The Contractor shall be responsible and shall pay for any permits, fees, and inspections required by the local power company for service installations. Three phase power shall be used unless otherwise approved by the Engineer. (No phase converters will be accepted.) All lift stations shall be equipped with a knife-type fused safety switch in a NEMA 4X stainless steel enclosure, lockable in the ON and OFF position, between the service meter and the control panel to permit servicing of the main breaker without removing the service meter. All meter bases shall be aluminum. Minimum service size shall be 100 amp.

### B. Conductors

All power conductors shall be single conductor, 600 volt, type THW or THHN stranded copper. Minimum conductor size shall be #12 AWG. ALUMINUM WIRE IS NOT PERMITTED. All control wiring shall be single conductor #14 AWG, 600 volt, type THHN stranded copper. All terminations and interconnections of control wiring shall be by means of compression-type lugs of the nylon self insulated type with an inner bronze insulation grip sleeve on identified terminal strips. All control wiring shall be color coded.

### C. Conduit

All power conductors from the utility source to the service meter shall be enclosed in PVC Schedule 80 conduit below ground and aluminum rigid conduit aboveground (NO I.M.C. ALLOWED). All lift stations shall be equipped with one conduit to the wetwell for pump power cables and a separate conduit to the wetwell for the control (floatball) cables. In lift stations where the pump power cords are 10/4 or larger, separate conduits shall be required for each pump power cable. In lift stations with large horsepower pumps and pumps equipped with sensor cables, the conduit size and quantity shall be determined by MCPWD. All conduit to the lift station wetwell shall be minimum 2" Schedule 80 PVC and shall be run by the shortest route possible. All terminations shall be made inside the electrical control panel, no junction boxes mounted under control panel for pump and float cables will be accepted. All flexible conduit shall be non-metallic.

### D. Control Panel

- All lift stations shall have one duplex automatic control panel. The enclosure shall be NEMA 3R 304 stainless steel and mounted on 3" stainless steel Schedule 40 pipes with aluminum or stainless steel Unistrut or Kindorf channel attached with stainless steel fasteners. The support posts shall be anchored in concrete adjacent to the lift station wetwell. No fittings shall enter from back of control panel. All fittings entering side of panel shall be sealing locknuts or Myers Hubs. The minimum panel size shall be 30"x30"x12". All components shall be industrial NEMA rated, no I.E.C. allowed. All panels shall be equipped with main and emergency circuit breakers (Min. 100 amp). All power conductors from the main breaker to the emergency and pump breakers shall be connected via a power distribution block. Controls shall be rated for 230 volts, 3-phase, 60hz, equipped with individual pump breakers, Furnas ESP-100 motor starters, 3-phase overload protection, lightening arrestor on incoming power source mounted on the EXTERIOR and wired to the LOAD SIDE of the safety switch and overload reset. Also, furnish and install four liquid level switches equipped with a continuous length of flexible 600 volt, type S.O. cable to make all connections inside the control panel (NO SPLICES SHALL BE PERMITTED). Each station shall have one flashing type red alarm light mounted on top of control panel, one adjustable audible alarm with silent button and one emergency generator receptacle of the type listed below with a mechanical interlink between the main and emergency circuit breakers to prevent backfeed. All test switches will be of the momentary contact type. All neutral wiring shall be connected via a neutral assembly (Sq. D #SN12-125 or equal).**

**E. Generator Receptacles:**

<b>0-100 amp., 230 Volt</b>	<b>Russell Stoll JRSB1044FR</b>
<b>100-200 amp., 230 Volt</b>	<b>Russell Stoll JRSB2044FR</b>
<b>0-200 amp., 460 Volt</b>	<b>Russell Stoll JRSB2034HR</b>

**F. Motor Starters**

**Motor starters shall be sized as called for on the plans. No starter smaller than NEMA size 1 shall be used. Starters shall be Furnas Model ESP-100 with phase loss protection and special factory coating of solid state circuit boards to prevent hydrogen sulfide damage.**

**G. Ground Resistance**

**Tests shall be made on the entire grounding system for the**

continuity of connections and for resistance to the flow or current through ground connections. The ground resistance of conduits, equipment cases, and supporting frames shall not vary appreciably from that of the system as a whole. The ground resistance of the system shall not exceed 5 ohms.

**3.01 REMOTE TERMINAL/PUMP CONTROL UNIT**

The remote terminal/pump control unit shall be TAC PAC (TAC II plus PCU 001) as manufactured by Data Flow Systems, Inc.

**4.01 WATER SERVICE**

All lift stations shall be equipped with a 3/4" lock shield and loose key water service (hose bib) adjacent to the valve vault. Each water service shall be equipped with a 5/8" water meter, a reduced pressure-type back flow preventer (Watts Model 909 or Equal) in accordance with Resolution 87-125, and a 3/4" brass hose bib. The water meter and backflow preventer shall be located within two feet of the lift station easement (or property) line. All water meters shall be obtained from the Public Works Department.

**5.01 PERMITS**

The Contractor shall be responsible for obtaining and shall pay for any permits and/or inspections required.

**6.01 SHOP DRAWINGS AND INSPECTIONS**

When calling for inspection, the Contractor shall have these approved shop drawings available on-site for review by the inspectors. The Contractor shall also deliver to the Lift Station Section inspector, the pump manufacturer's technical manual with the model number, serial number, and certified pump curve, for each pump prior to acceptance by MCPWD for maintenance.

**7.01 EASEMENTS**

An easement for ingress and egress to the lift station and an easement for the lift station must be granted and recorded before the lift station can be accepted by MCPWD for operation and maintenance.

**8.01 LANDSCAPING**



**The Contractor shall be responsible for providing a landscaped screening or buffer with irrigation and shall maintain the lift station site in accordance with the Manatee County Land Development Code Section 715 unless a waiver is requested and approved by the Department of Public Works Director or his designee.**

**9.01 FLOODING**

**Wastewater pumping station structures and electrical and mechanical equipment shall be fully protected from physical damage and flood water intrusion by the 100 year flood. Wastewater pumping stations should remain fully operational and accessible during the 25 year flood. Regulations of state and federal agencies regarding flood plain obstructions shall be considered.**

**10.01 ACCESSIBILITY AND SECURITY**

**The pumping station shall be readily accessible by maintenance vehicles during all weather conditions. The facility shall be located off the traffic way of streets and alleys. Security fencing and access hatches with locks shall be provided.**

**END OF SECTION**  
**MINIMUM RECORD DRAWING STANDARDS FOR ALL RECORD DRAWINGS**  
**SUBMITTED TO MANATEE COUNTY**

1. All valves, fire hydrants, manholes, water, reclaim water and sewer services, water and force main fittings, underdrain cleanouts, catch basins, junction boxes and any other structures located in the right-of-way or an easement, shall be located by elevation and by station and offset based on intersection PI's and centerline of right-of-way. For facilities located on private roads, the dimensioning shall be from centerline of paving or another readily visible baseline.
2. Elevations shall be provided as listed above and for all manhole rim and inverts; junction box rim and inverts; catch basin rim and inverts; and baffle, weir and invert elevations in control structures. Elevations shall also be provided at the PVI's and at every other lot line or 200 feet, whichever is less, of drainage swales and ditches. Bench marks and elevation datum shall be indicated.
3. Slopes for pipe and ditches shall be recalculated, based on actual field measured distances, elevations, pipe size and type shown. Cross section of drainage ditches and swales shall be verified.
4. Centerline of roads shall be tied to right-of-way lines. Elevation of roadway centerline shall be given at PVI's and at all intersections.
5. Record drawings shall show bearings and distances for all right-of-way and easement lines, and property corners.

6. **Locations and elevations of drainage ditches, swales, water lines and force mains shall be shown every 200 feet (measured along the centerline) or alternate lot lines, whichever is closer. Dimensions at these locations shall indicate distance from the centerline of right-of-way to the facility.**
7. **Sidewalks, fences and walls, if installed at the time of initial record drawing submittal, shall be located every 200 feet or alternate lot lines, whichever is closer. Dimensions shall include distance from the right-of-way line and the back of curb and lot line or easement line.**
8. **Underdrain cleanouts for retention systems outside the right-of-way shall be located by station and offset from an appropriate baseline.**
9. **Sanitary sewer mainline wyes shall be located from the downstream manhole. These dimensions shall be provided by on-site inspections or televising of the sewer following installation.**
10. **Elevations shall be provided on the top of operating nuts for water and force main valves at major intersections connecting to County and/or State roads at proposed or existing arterial highways and at drain crossings.**
11. **Allowable tolerance shall be  $\pm 6$  inches for horizontal dimensions. Vertical dimensions such as the difference in elevations between manhole inverts shall have an allowable tolerance of  $\pm 1/8$  inch per 50 feet (or part thereof) of horizontal distance up to a maximum of  $\pm 1/2$  inch.**
12. **Record drawings shall be certified by the design professionals (Engineer and Surveyor licensed in Florida), as stipulated by the Land Development Ordinance and submitted on signed and dated mylar drawings together with 3-1/2" diskettes, AutoCad Release 12 or later for review and the use of the County in the following format:**

**The diskettes shall contain media in AutoCAD version 12 or later, or in any other CAD program compatible with AutoCAD in DWG or DXF form. Where large projects or exceptionally large files prohibit the use of diskettes, the files will be accepted on a CD ROM. All fonts, line types, shape files or other pertinent information used in the drawing and not normally included in AutoCAD shall be included on the media with a text file or attached note as to its relevance and use.**

**All record drawing requirements must be submitted to the Engineer prior to starting the bacteria testing of water lines.**

**Accompany submittal with transmittal letter in duplicate containing:**



1. **Date.**
2. **Project title and number.**
3. **Contractor's name and number.**
4. **Title and number of each Record Document.**
5. **Signature of Contractor or his authorized representative.**

**Note:** The data required to properly prepare these record drawings shall be obtained at the site, at no cost to the County by the responsible design professional or his/her duly appointed representative. The appointed representative shall be a qualified employee of the responsible design professional or a qualified inspector retained by the responsible design professional on a project-by-project basis.

**END OF SECTION**



# **MANATEE COUNTY PUBLIC WORKS DEPARTMENT ENGINEERING DIVISION**

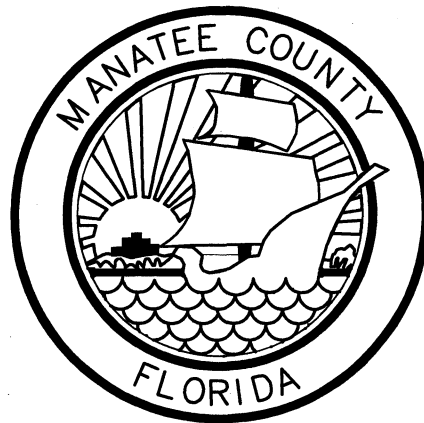

**MARCH 1997  
REVISED NOVEMBER 1999**

# **STANDARDS FOR RECLAIMED WATER SYSTEM**

URW-0

SUBSTANTIAL EFFORT HAS BEEN MADE TO ENSURE THE INFORMATION IN THESE STANDARDS IS ACCURATE HOWEVER, MANATEE COUNTY PUBLIC WORKS DEPT. CANNOT ACCEPT RESPONSIBILITY FOR ANY ERRORS OR OVERSIGHT IN THE USE OF THE MATERIAL OR IN THE PREPARATION OF THE ENGINEERING PLANS. THIS PUBLICATION IS INTENDED FOR USE BY PROFESSIONAL PERSONNEL COMPETENT TO EVALUATE THE SIGNIFICANCE AND LIMITATIONS OF IT'S CONTENTS AND ABLE TO ACCEPT RESPONSIBILITY FOR THE APPLICATION OF THE MATERIAL IT CONTAINS.

THE DESIGNER MUST RECOGNIZE THAT NO HANDBOOK OR CODE CAN BE A SUBSTITUTE FOR EXPERIENCED ENGINEERING JUDGEMENT.

USERS OF THESE STANDARDS ARE ENCOURAGED TO OFFER COMMENTS TO MANATEE COUNTY PUBLIC WORKS DEPARTMENT ON THE CONTENTS OF THIS PUBLICATION AND SUGGESTIONS FOR CHANGES IN THE FUTURE EDITIONS.

PRODUCTS TO BE CONSIDERED "APPROVED EQUAL" SHALL BE SUBMITTED TO THE PUBLIC WORKS DIRECTOR FOR APPROVAL.

THESE RECOMMENDATIONS ARE UNDER CONSTANT REVIEW AND ARE SUBJECT TO CHANGES APPROVED BY THE DIRECTOR OF PUBLIC WORKS.

MANATEE COUNTY PUBLIC WORKS DEPARTMENT		INTRODUCTION MANATEE COUNTY UTILITY STANDARDS	URW-1
REV. BY	DATE		
	MARCH 18, 1997		
	DATE OF APPROVAL		



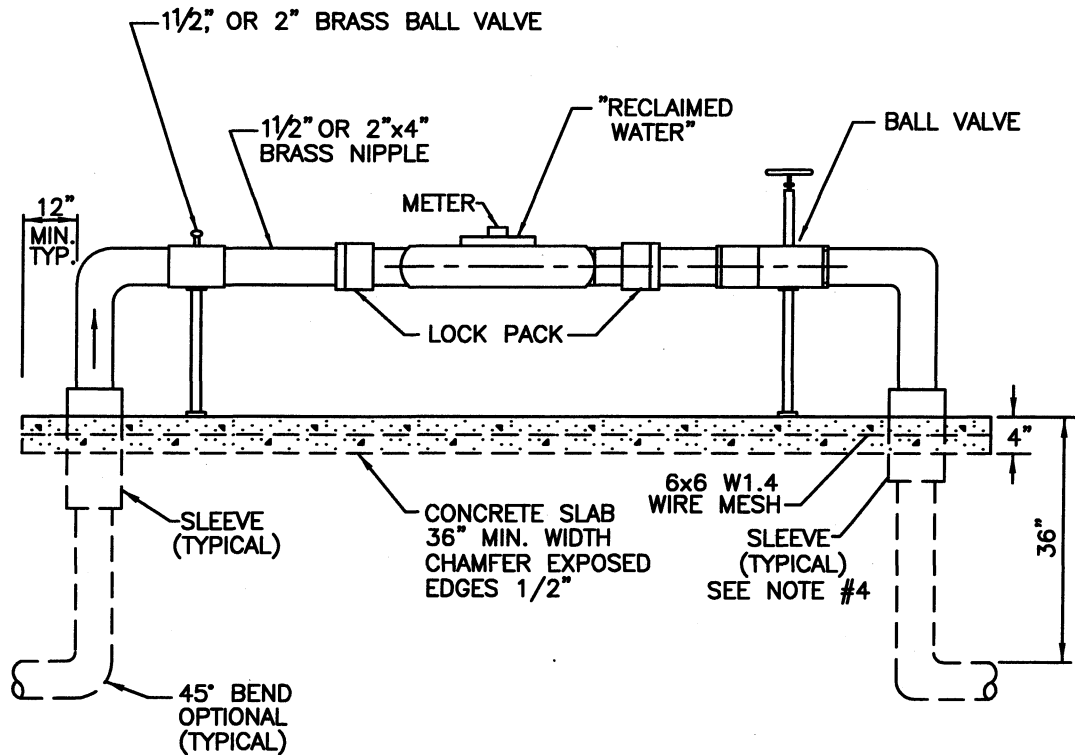

NOTES:

1. BOTTOM OF BACKFLOW DEVICE, IF REQUIRED, MUST BE 12" ABOVE FINISHED GRADE.
2. BACKFLOW DEVICE, IF REQUIRED, MUST BE INSTALLED DOWNSTREAM OF METER, AS CLOSE TO METER AS POSSIBLE.
3. COPPER PIPE TYPE "L" OR "K" OR BRASS PIPE MINIMUM SCHEDULE 40 SHALL BE USED TO A MINIMUM DEPTH OF 36" BELOW GRADE.
4. PIPES PASSING THROUGH OR ENCASED IN CONCRETE MUST BE PROPERLY PROTECTED AND SLEEVED.
5. THE SYSTEM MUST MEET ALL REQUIREMENTS OF THE MANATEE COUNTY PLUMBING CODE (Latest Edition) AND THE MANATEE COUNTY BACKFLOW PREVENTION CODE (Latest Edition).
6. A BACKFLOW PREVENTER SHALL BE LOCATED AFTER METER IF REQUIRED TO PREVENT CONTAMINATION FROM ATTACHED CHEMICAL OR FERTILIZER INJECTION METHODS.
7. METER, LOCK PACKS, METER COUPLINGS AND BRASS NIPPLES FURNISHED BY MCPWD.
8. BACKFLOW PREVENTER IS REQUIRED WITH METER, ONLY WHEN IRRIGATION SYSTEM INCLUDES CHEMICAL/FERTILIZER INJECTION METHODS.

<b>MANATEE COUNTY</b> PUBLIC WORKS DEPARTMENT		1 1/2", & 2" METER DETAIL	URW-10
REV. BY	DATE		
RTH	11/99	MARCH 18, 1997 <hr style="width: 50%; margin: auto;"/> DATE OF APPROVAL	

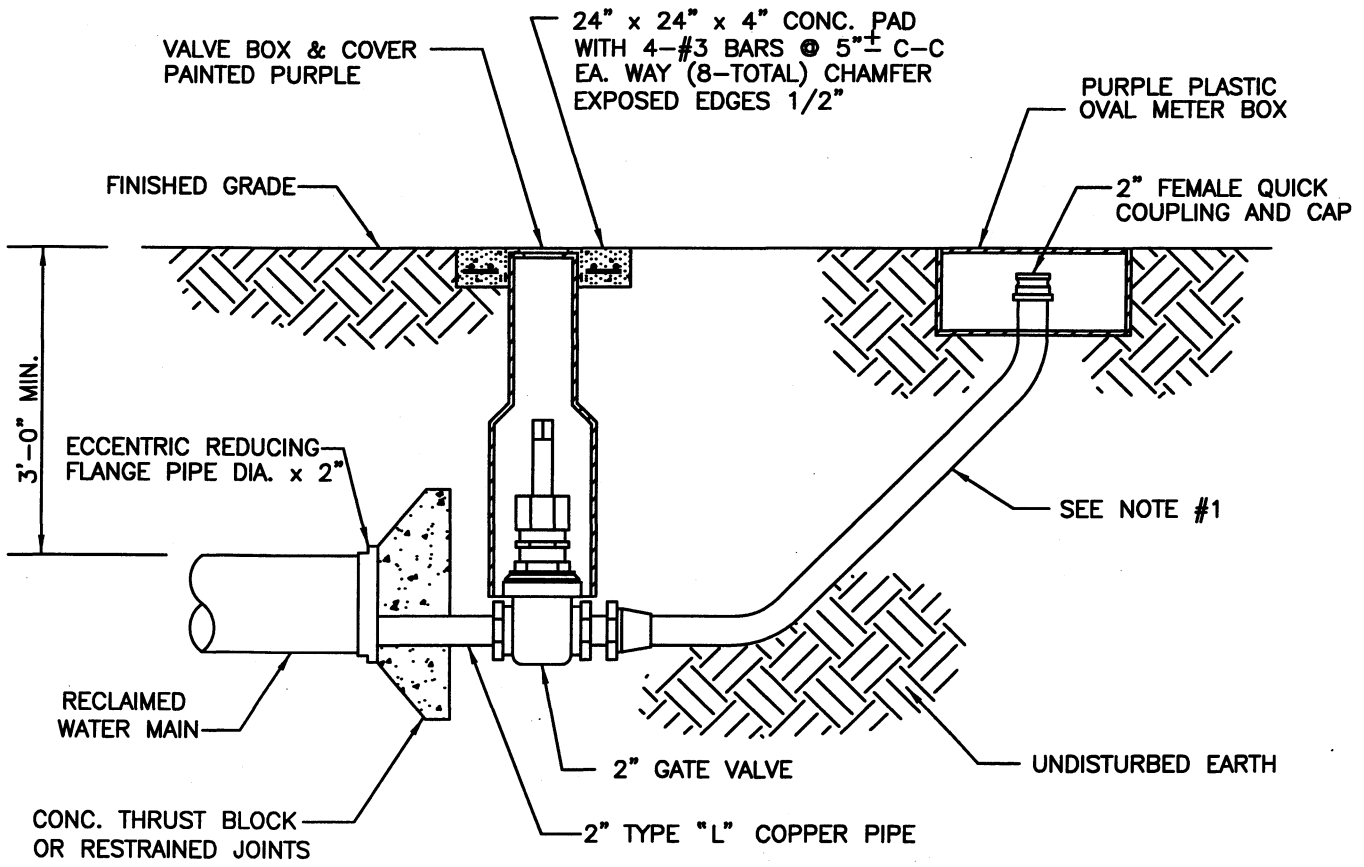

NOTES:

1. POLYETHYLENE SERVICE PIPE MEETING AWWA C-901, SHALL BE POLY-E DRISCOPIPE 5100 ULTRA-LINE OR ENDOPURE BY ENDOT OR APPROVED EQUAL. PIPE SHALL BE PURPLE OR ENCASED IN PURPLE SLEEVE.
2. IF FUTURE RECLAIMED WATER MAIN EXTENSION BEYOND THIS PLUG IS POSSIBLE, PROVIDE A MAIN LINE GATE VALVE BETWEEN THIS PLUG AND THE LAST SERVICE BUT THE DISTANCE BETWEEN THE IN-LINE VALVE AND THE PLUG SHALL NOT EXCEED 40 FT.
3. THIS DETAIL TO BE USED FOR ALL RECLAIMED WATER MAINS 10" DIA. OR SMALLER.

<b>MANATEE COUNTY</b> PUBLIC WORKS DEPARTMENT		END OF LINE 2" BLOW-OFF ASSEMBLY	URW-11
REV. BY	DATE	MARCH 18, 1997 <hr style="width: 50%; margin: 0 auto;"/> DATE OF APPROVAL	
RTH	11/99		

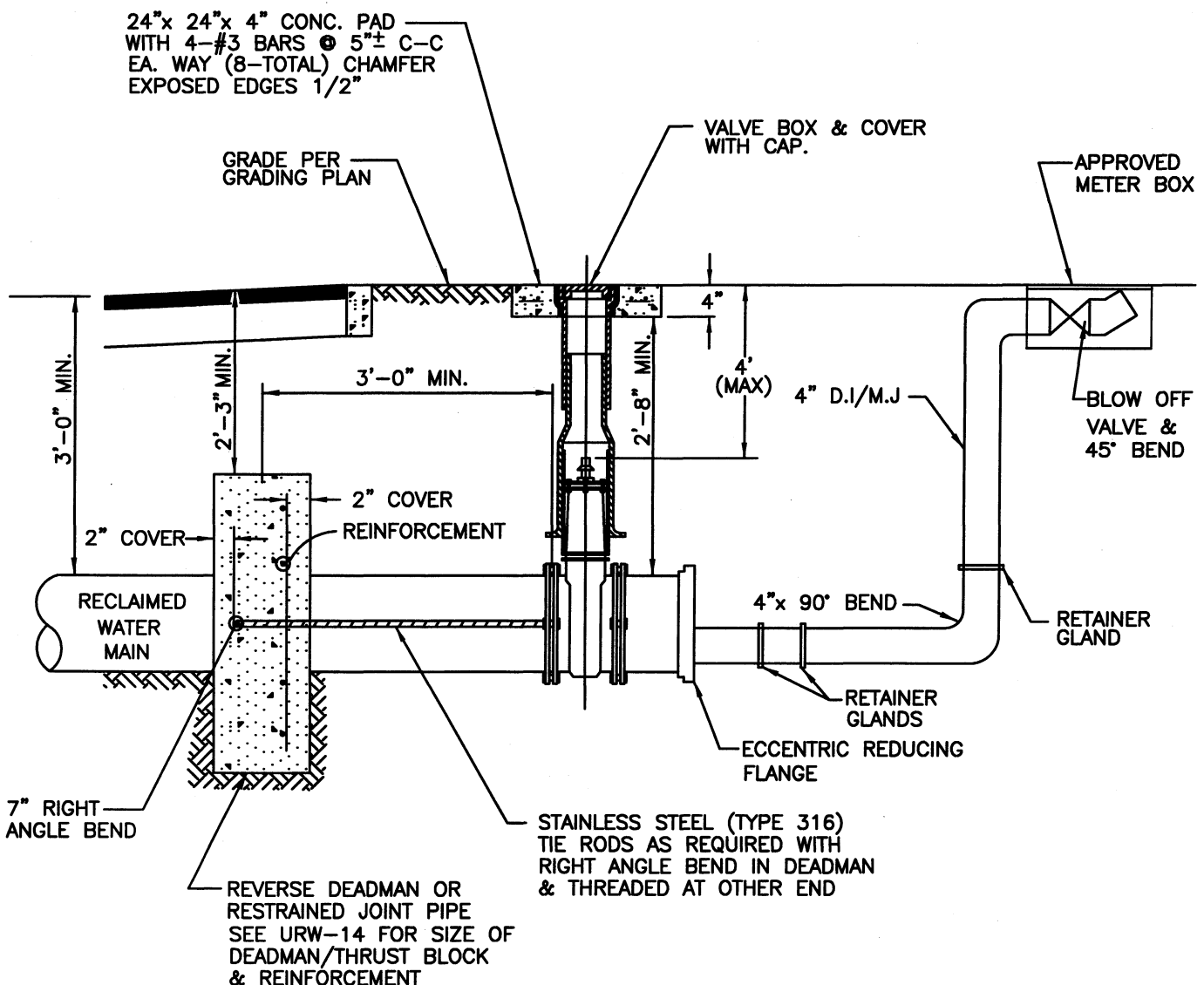

**NOTE:**

THIS DETAIL TO BE USED FOR ALL RECLAIMED WATER MAINS LARGER THAN 10" DIA.

MANATEE COUNTY PUBLIC WORKS DEPARTMENT		4" AND LARGER BLOW-OFF ASSEMBLY	URW-12
REV. BY	DATE		
	MARCH 18, 1997		
	DATE OF APPROVAL		

**NOTES:**

- 1.) METER BOXES & YOKE ARE TO BE INSTALLED BY THE INFRASTRUCTURE CONTRACTOR AND WILL NOT BE SET IN DRAINAGE SWALES, EASEMENTS OR SIDEWALKS.
- 2.) SERVICES TO BE MARKED IN CURB WITH A PURPLE DISC THAT HAS FOOTAGE FROM THE BACK OF CURB TO THE CENTER OF THE METER BOX OR IF NO CURB, A PURPLE DISC IN THE EDGE OF PAVEMENT WITH THE FOOTAGE FROM THE DISC TO THE CENTER OF THE METER BOX.

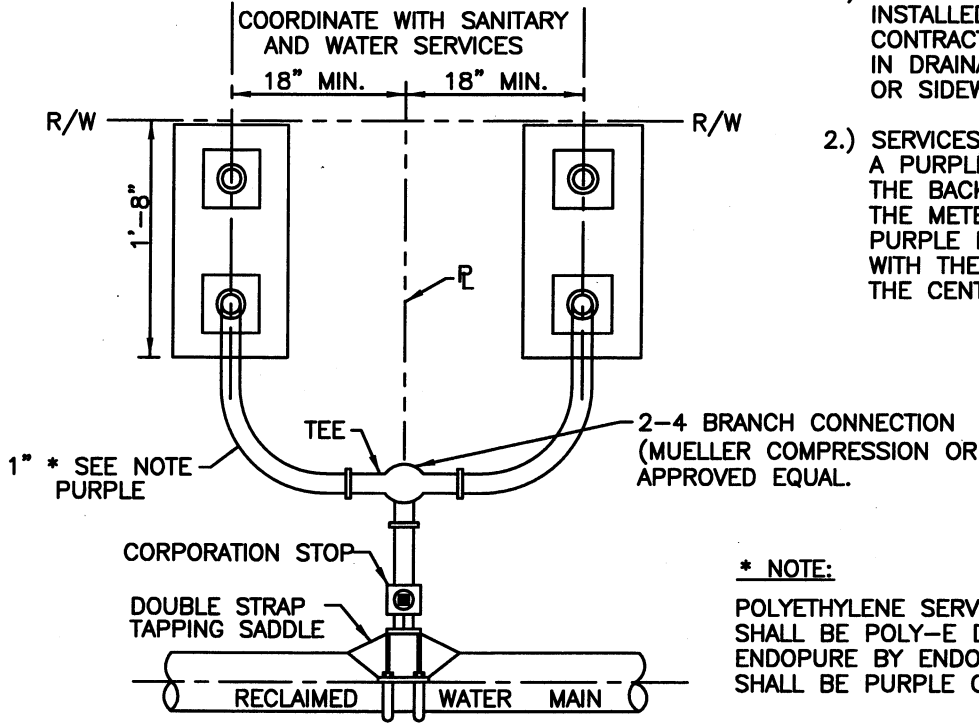

**\* NOTE:**

POLYETHYLENE SERVICE PIPE MEETING AWWA C-901, SHALL BE POLY-E DRISCOPIPE 5100 ULTRA-LINE OR ENDOPURE BY ENDOT OR APPROVED EQUAL. PIPE SHALL BE PURPLE OR ENCASED IN PURPLE SLEEVE.

**PLAN**

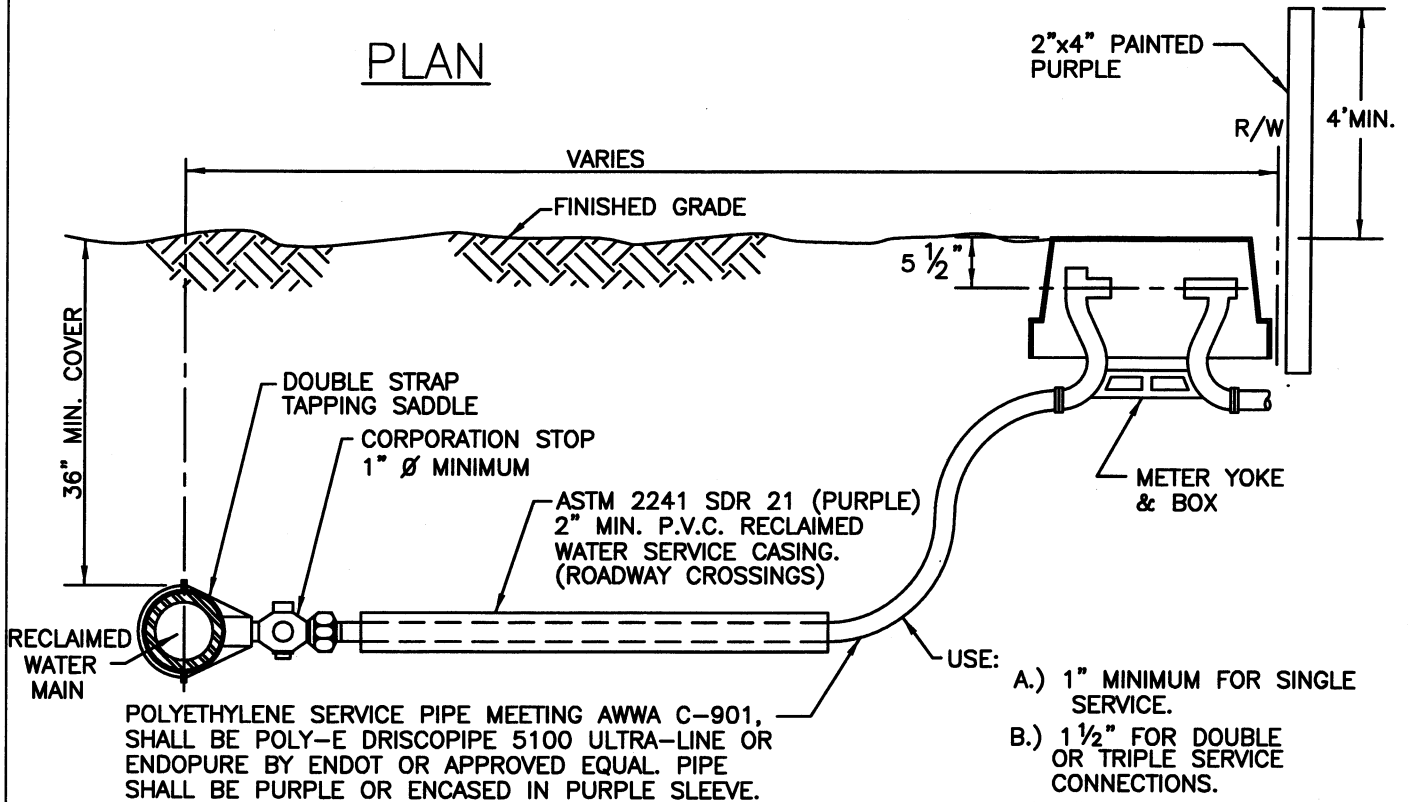

**SECTION**

**NOTES:**

1. ALL SERVICE TAPS TO BE LOCATED IN FIELD. TAPS SHALL BE NO CLOSER THAN 2'-0" STAGGERED INTERVALS OR WITHIN 2'-0" FROM BELL OR SPIGOT ENDS.
2. METER YOKE AND BOX TO BE FURNISHED AND INSTALLED BY THE INFRASTRUCTURE CONTRACTOR.

- USE:
- A.) 1" MINIMUM FOR SINGLE SERVICE.
  - B.) 1 1/2" FOR DOUBLE OR TRIPLE SERVICE CONNECTIONS.
  - C.) 2" FOR QUADRUPLE SERVICE USING 3" CASING.

MANATEE COUNTY  
PUBLIC WORKS DEPARTMENT

TYPICAL  
RECLAIMED WATER  
SERVICE CONNECTION

URW-13

REV. BY	DATE

MARCH 18, 1997  
DATE OF APPROVAL

THRUST BLOCK DIMENSIONS B ft. x d inches												
PIPE SIZE (IN.)	90° BEND		45° BEND		22.5° BEND		11.25° BEND		DEAD END & TEE		45° WYE	
	B	d	B	d	B	d	B	d	B	d	B	d
4	1.3	3 1/2	1.0	3 1/2	0.7	3 1/2	0.6	3 1/2	1.1	3 1/2	1.0	3 1/2
6	1.9	4 1/2	1.5	3 3/4	1.1	3 1/2	0.8	3 1/2	1.6	4	1.5	3 3/4
8	2.6	6 1/4	1.9	4 3/4	1.4	3 1/2	1.0	3 1/2	2.2	5 1/2	1.8	4 1/2
10	3.2	7 3/4	2.4	6	1.7	4 1/4	1.2	3 1/2	2.7	6 1/2	2.3	5 1/2
12	3.8	9 1/4	2.8	6 3/4	2.0	5	1.5	3 3/4	3.2	7 3/4	2.7	6 1/2
14	4.5	11	3.3	8	2.4	6	1.7	4 1/4	3.8	9 1/4	3.2	7 3/4
16	5.1	12 1/4	3.8	9 1/4	2.7	6 1/2	1.9	4 3/4	4.3	10 1/2	3.6	8 3/4
18	5.7	13 3/4	4.2	10 1/4	3.0	7 1/4	2.2	5 1/2	4.8	11 3/4	4.1	10
20	6.4	15 1/2	4.7	11 1/2	3.4	8 1/4	2.4	6	5.4	13	4.5	11
24	7.6	18 1/4	5.6	13 1/2	4.0	9 3/4	2.9	7	6.4	15 1/2	5.4	13
30	9.5	23	7.0	17	5.0	12	3.6	8 3/4	8.0	19 1/4	6.7	16
36	11.4	27 1/2	8.4	20 1/4	6.0	14 1/2	4.3	10 1/2	9.6	23	8.1	19 1/2

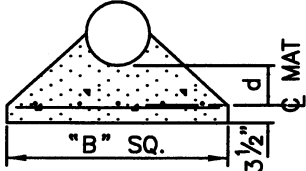

**REINFORCEMENT MAT SCHEDULE**

FOR DIM. "B" BETWEEN 5.75' & 11.5' USE #4 @ 8" EACH WAY

FOR DIM. "B" LESS THAN 5.75' USE #3 @ 8" EACH WAY

**NOTES:**

- THIS TABLE IS BASED ON WATER PRESSURE=180 PSI WITH AN ALLOWABLE SOIL BEARING PRESSURE=2000 PSF, CONCRETE STRENGTH  $f_c=3000$  PSI, REINFORCEMENT  $f_y=60.0$  KSI THRUST BLOCK CAST AGAINST FIRM UNDISTURBED OR COMPACTED SOIL.
- FOR LARGER "B" DIMENSIONS IT IS NECESSARY TO CHECK THAT PIPE IS SUFFICIENTLY DEEP TO ALLOW 15" MIN. SOIL COVER OVER TOP EDGE OF THRUST BLOCK.

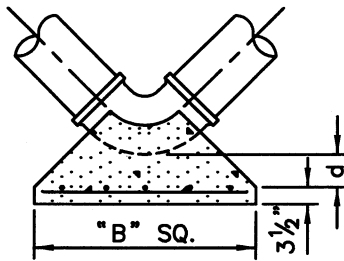

**90° BEND**

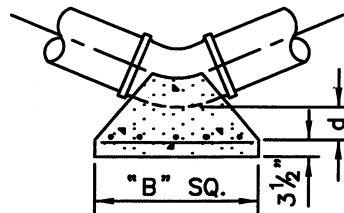

**45°, 22.5° OR 11.25° BEND**

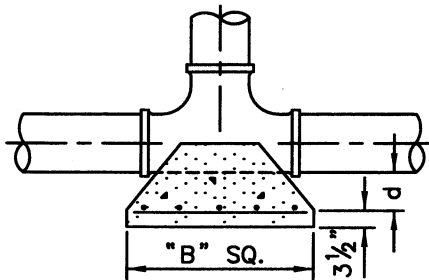

**TEE OR DEAD END**

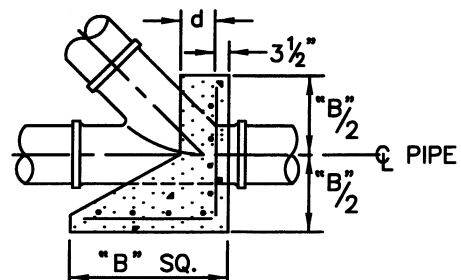

**45° WYE**

<b>MANATEE COUNTY</b> PUBLIC WORKS DEPARTMENT		<b>THRUST BLOCK          DETAILS</b>	<b>URW-14</b>
REV. BY	DATE		
MARCH 18, 1997 DATE OF APPROVAL			

## REQUIRED LENGTH OF RESTRAINED JOINT PIPE FOR DR-18 PVC PIPE

MAIN PIPE SIZE	HORIZ. BENDS			TEES					REDUCERS			PLUGS
	90°	45°	22.5°	SIZE					SIZE			
				LENGTH					LENGTH			
24	90	38	18	X24 177	X20 139	X16 94	X12 40	X10 6	X20 64	X16 117	X12 158	214
20	78	32	15	X20 148	X16 105	X12 56	X10 25	X8 0	X16 65	X12 115	X10 149	184
16	66	27	13	X16 116	X12 70	X10 42	X8 12		X12 64	X10 90	X8 111	151
12	51	22	10	X12 83	X10 59	X8 32	X6 0		X10 34	X8 62	X6 86	118
10	44	18	9	X10 66	X8 41	X6 8			X8 33	X6 61	X4 81	100
8	37	15	7	X8 50	X6 21	X4 0			X6 35	X4 59		83
6	29	12	5	X6 30	X4 0				X4 32			63
4	21	8	4	X4 14								45

**NOTES:**

- 1.) RESTRAIN TO NEXT FULL JOINT BEYOND GIVEN LENGTH.
- 2.) RESTRAIN 11.25' BENDS 50% OF LENGTH FOR 22.5' BENDS.
- 3.) ALL VALVES AND FITTINGS SHALL BE RESTRAINED TO THE CONNECTING SECTIONS OF PIPE.
- 4.) ALL VALVES MUST BE PROPERLY ANCHORED OR RESTRAINED TO RESIST A 180 PSI TEST PRESSURE IN EITHER DIRECTION.
- 5.) PIPE SIZES ARE GIVEN IN INCHES.
- 6.) PIPE LENGTHS ARE GIVEN IN FEET.
- 7.) LENGTHS SHOWN ARE FOR A TEST PRESURE OF 180 PSI.
- 8.) THE RESTRAINED LENGTHS SHOWN IN THESE TABLES ARE BASED ON THE USE OF LIGHTLY COMPACTED CLEAN SAND WITH AT LEAST A 95% COARSE PARTICLE CONTENT. ACTUAL SOIL CONDITIONS MUST BE DETERMINED BY THE ENGINEER OF RECORD AND THE RESTRAINED LENGTHS MODIFIED ACCORDINGLY.

MANATEE COUNTY PUBLIC WORKS DEPARTMENT		RESTRAINED LENGTHS FOR PVC PIPE	UW-14A
REV. BY	DATE		
NOVEMBER 1, 1999			
DATE OF APPROVAL			

## REQUIRED LENGTH OF RESTRAINED JOINT PIPE FOR DIP (POLY-WRAPPED)

MAIN PIPE SIZE	HORIZ. BENDS			TEES							REDUCERS				PLUGS
	90°	45°	22.5°	SIZE							SIZE				
				LENGTH							LENGTH				
36	116	48	23	x36 282	x30 232	x24 175	x20 130	x16 77	x12 11	X30 96	X24 173	X20 216	X16 257	317	
30	102	42	20	X30 241	X24 186	X20 144	X16 95	X12 35	x10 0	X24 96	X20 150	X16 194		275	
24	87	36	17	X24 197	X20 157	X16 112	X12 58	X10 25	x8 0	X20 69	X16 125	X12 170		230	
20	75	31	15	X20 165	X16 122	X12 72	X10 41	x8 6		X16 69	X12 123	X10 145		197	
16	63	26	13	X16 132	X12 85	X10 57	X8 25	x6 0		X12 69	X10 97	X8 119		163	
12	50	21	10	X12 97	X10 71	X8 43	x6 7			X10 37	X8 68	X6 93		128	
10	43	18	9	X10 78	X8 52	x6 19				X8 37	X6 67	X4 89		109	
8	36	15	7	X8 60	X6 29	x4 0				X6 38	X4 65			90	
6	28	12	6	X6 40	x4 5					X4 36				70	
4	20	8	4	x4 19										49	

## REQUIRED LENGTH OF RESTRAINED JOINT PIPE FOR DIP (NON-WRAPPED)

MAIN PIPE SIZE	HORIZ. BENDS			TEES							REDUCERS				PLUGS
	90°	45°	22.5°	SIZE							SIZE				
				LENGTH							LENGTH				
36	100	42	20	x36 198	x30 162	x24 123	x20 91	x16 54	x12 7	X30 67	X24 121	X20 151	X16 176	222	
30	88	37	18	X30 169	X24 131	X20 101	X16 67	X12 25	x10 0	X24 67	X20 105	X16 136		192	
24	75	31	15	X24 138	X20 110	X16 78	X12 40	X10 17	x8 0	X20 48	X16 88	X12 119		161	
20	65	27	13	X20 115	X16 86	X12 50	X10 29	x8 4		X16 48	X12 86	X10 101		138	
16	54	22	11	X16 92	X12 59	X10 40	x8 18	x6 0		X12 49	X10 68	X8 83		114	
12	43	18	8	X12 68	X10 50	X8 30	x6 5			X10 26	X8 47	X6 65		89	
10	37	15	7	X10 55	X8 36	x6 13				X8 26	X6 47	X4 62		76	
8	30	13	6	X8 42	X6 20	x4 0				X6 26	X4 45			63	
6	24	10	5	X6 28	x4 4					X4 25				49	
4	17	7	3	x4 14										34	

**NOTE:**

SEE DETAIL UW-14A FOR NOTES 1 THRU 8

MANATEE COUNTY PUBLIC WORKS DEPARTMENT		RESTRAINED LENGTHS FOR DIP	URW-14B
REV. BY	DATE		
NOVEMBER 1, 1999 DATE OF APPROVAL			

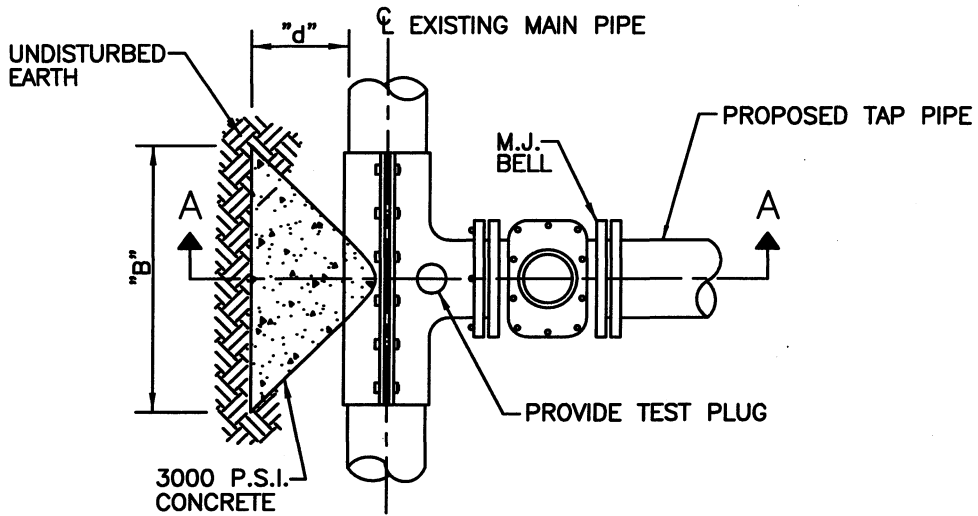

PLAN

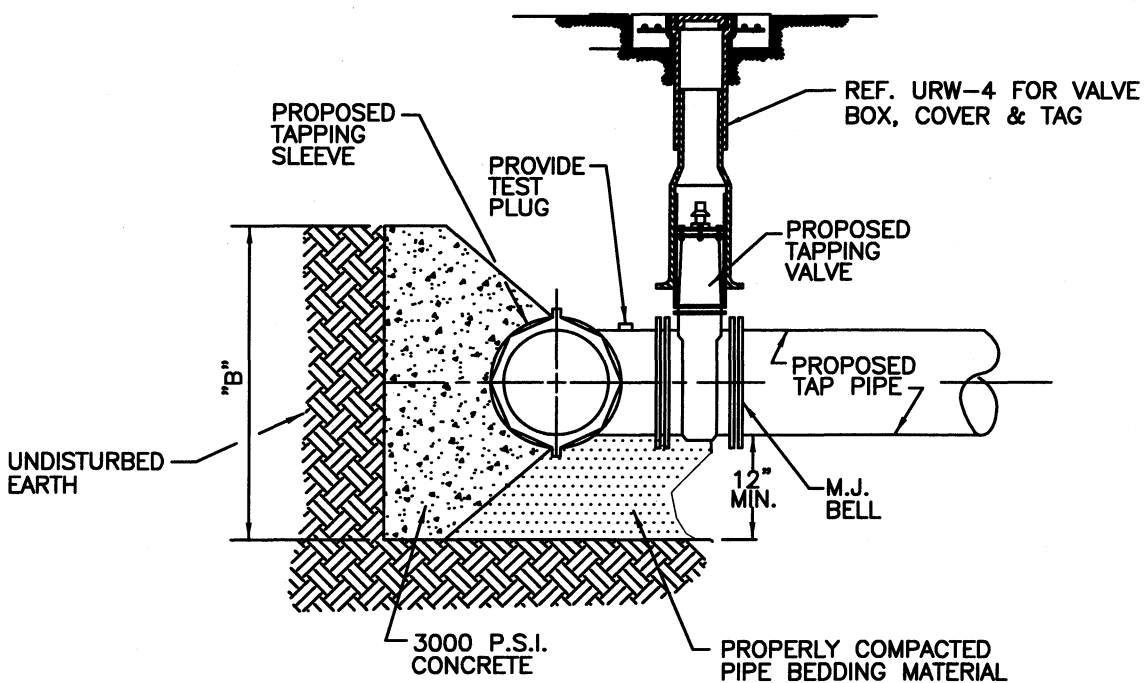

SECTION A-A

FOR DIMENSIONS "B" AND "d"  
SEE URW-14; THRUST BLOCK DETAILS

NOTES:

- 1.) NO CUTS SHALL BE MADE BEFORE:
  - (A) A TEST OF 180 P.S.I. FOR 60 MINUTES IS MADE.
  - (B) ALL FITTINGS TO BE WRAPPED WITH 20 MIL VISQUEEN AT THRUST BLOCK
  - (C) ALL TAPS TO BE MADE BY M.C.P.W.D. AND MATERIAL TO BE FURNISHED BY THE INFRASTRUCTURE CONTRACTOR.
- 2.) ALL TAPS MUST BE OF A SMALLER SIZE THAN THE MAIN BEING TAPPED & PLACED NO CLOSER THAN 30" OR A DISTANCE EQUAL TO (1) MAIN PIPE DIAMETER PLUS (2) TAP PIPE DIAMETERS (WHICHEVER IS LARGER) FROM A JOINT OR FITTING.
- 3.) CONTRACTOR TO SUPPLY A DRY HOLE FOR TAPPING CREW TO WORK AND A BACK-HOE TO LOWER MACHINE INTO HOLE.

MANATEE COUNTY  
PUBLIC WORKS DEPARTMENT

REV. BY	DATE
RTH	11/99

MARCH 18, 1997  
DATE OF APPROVAL

TAPPING SLEEVE &  
VALVE BLOCKING DETAIL

URW-15



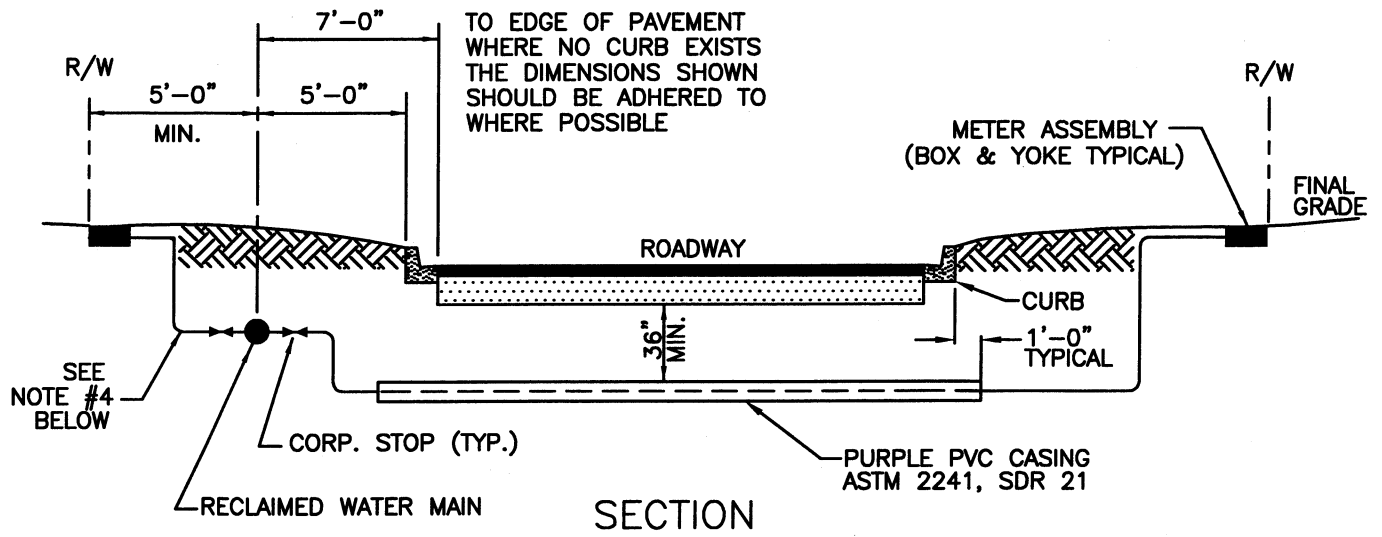

**SECTION**

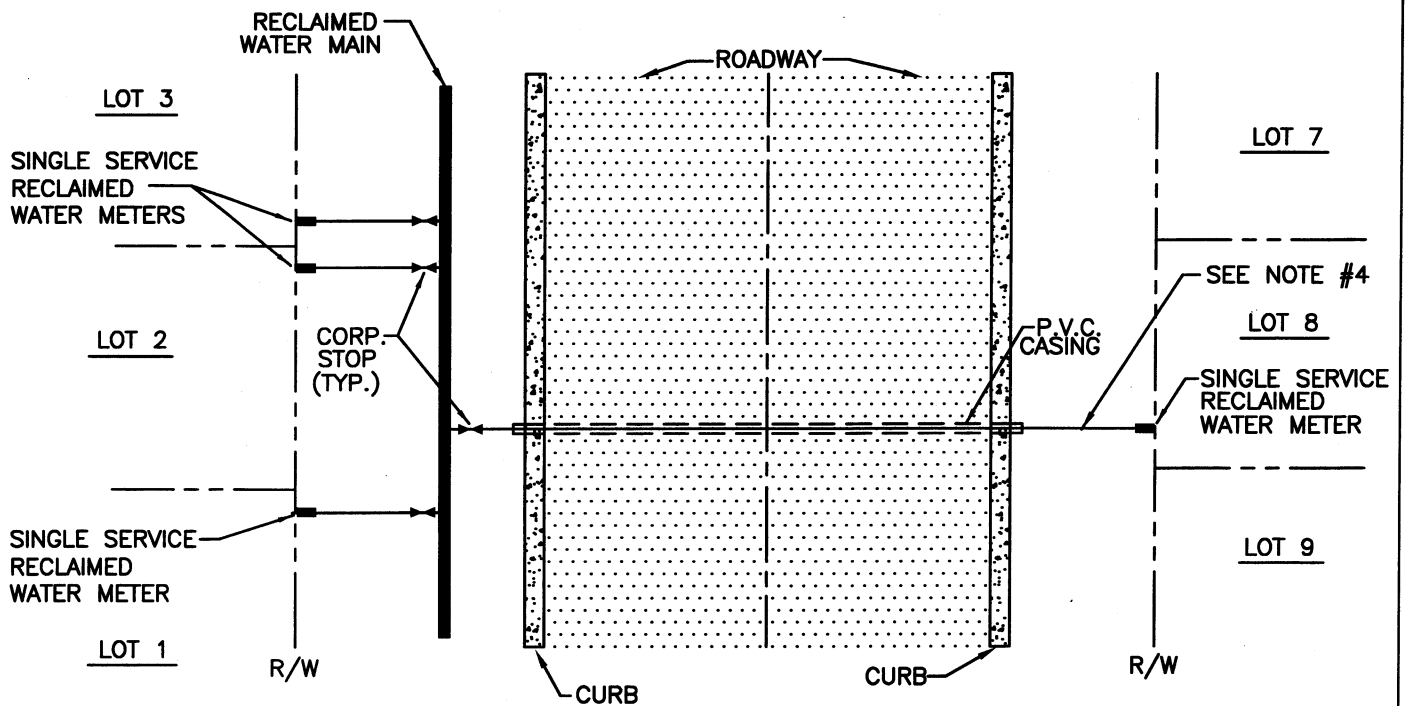

**PLAN**

**NOTES:**

1. RECLAIMED WATER METER SERVICE SHALL BE LOCATED TO AVOID CONFLICT WITH FPL TRANSFORMER LOCATIONS.
2. FPL ELECTRICAL CONDUCTOR AND TRANSFORMER MAY BE ON EITHER SIDE OF THE ROADWAY.
3. ALL METER BOX & YOKE ASSEMBLIES TO BE INSTALLED BY THE INFRASTRUCTURE CONTRACTOR.
4. POLYETHYLENE SERVICE PIPE MEETING AWWA C-901 SHALL BE POLY-E DRISCOPIPE 5100 ULTRA-LINE OR ENDOPURE BY ENDOT OR APPROVED EQUAL. PIPE SHALL BE PURPLE OR ENCASED IN PURPLE SLEEVE.
5. EXACT METER LOCATIONS SHALL BE COORDINATED WITH OTHER UTILITY SERVICES.
6. WHERE POSSIBLE RECLAIMED WATER MAINS SHALL BE LOCATED ON THE NORTHERLY AND WESTERLY SIDE OF ROADS AND ON THE OPPOSITE SIDE OF ROAD FROM THE WATER MAIN.

MANATEE COUNTY  
PUBLIC WORKS DEPARTMENT

SINGLE SERVICE  
RECLAIMED WATER

URW-16

REV. BY	DATE
RTH	11/99

MARCH 18, 1997  
DATE OF APPROVAL

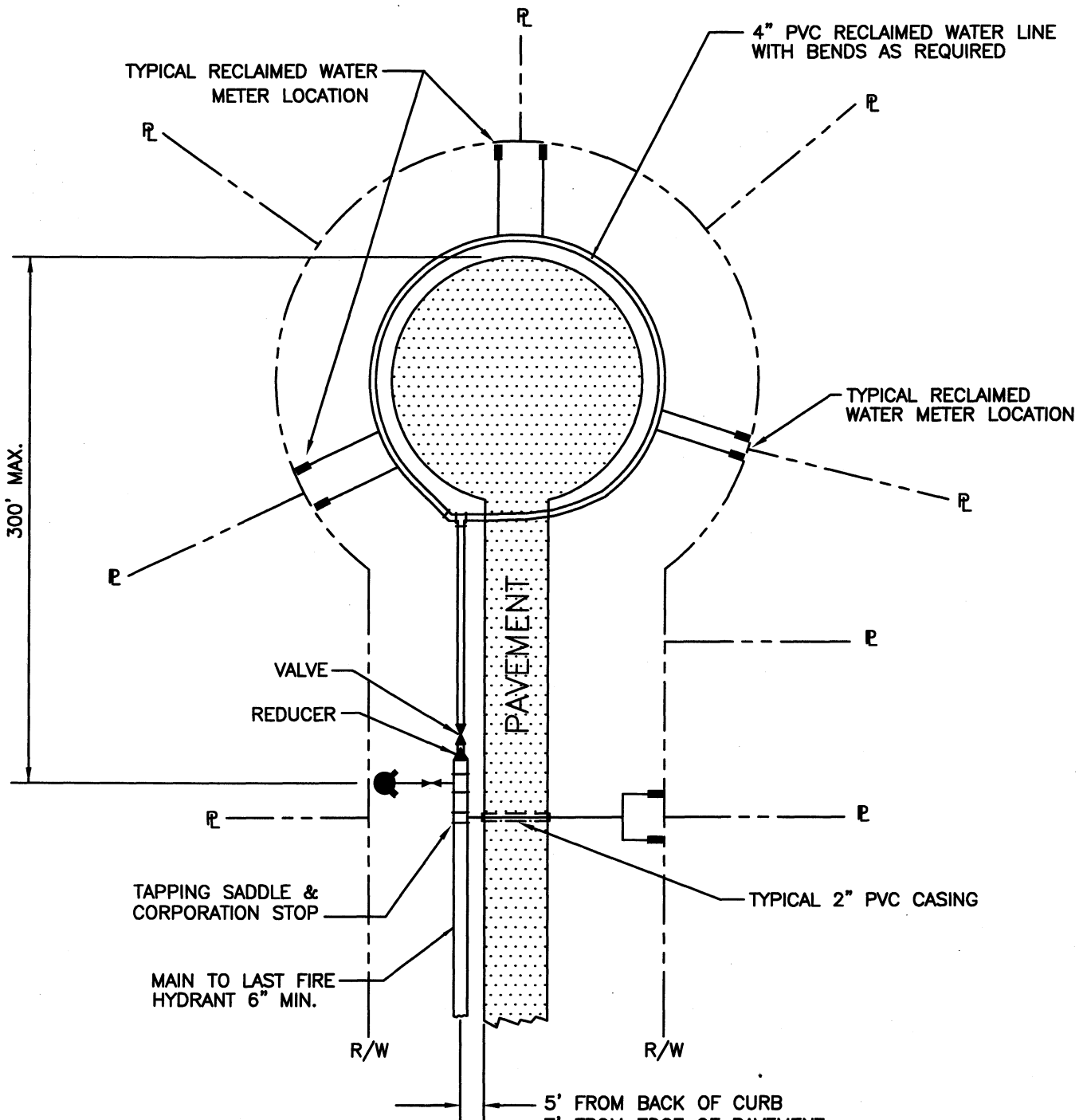

**NOTES:**

1. REDUCE MAIN TO 4" PVC (C-900) FOR PERMANENT CUL-DE-SAC CONNECTIONS ONLY. FITTINGS AS REQUIRED.
2. 5'-0" MIN. SEPARATION BETWEEN POTABLE WATER, RECLAIMED WATER AND WASTE WATER SHALL BE MAINTAINED.

5' FROM BACK OF CURB  
 7' FROM EDGE OF PAVEMENT  
 WHERE POSSIBLE LOCATE ON  
 NORTHERLY AND WESTERLY  
 SIDE OF ROAD AND ON THE  
 OPPOSITE SIDE OF ROAD  
 FROM THE WATER LINE.

MANATEE COUNTY  
 PUBLIC WORKS DEPARTMENT

RECLAIMED WATER  
 CUL-DE-SAC DETAIL

URW-17

REV. BY	DATE	MARCH 18, 1997
RTH	11/99	
		DATE OF APPROVAL

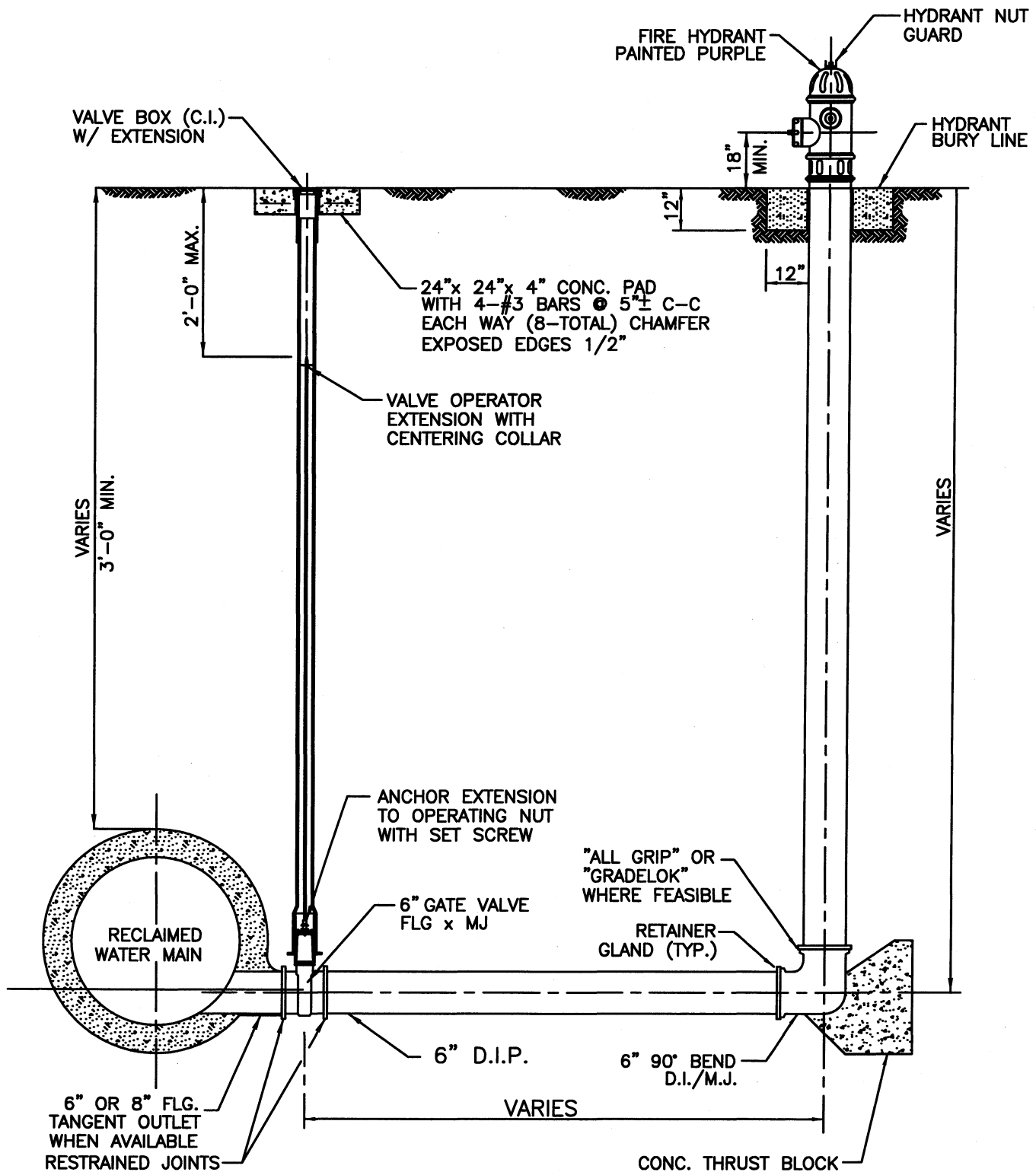

**NOTES:**

1. ALL PIPE TO BE DUCTILE IRON, CLASS 50 (MIN).
2. ALL BOLTED FITTINGS SHALL BE WRAPPED WITH POLYETHYLENE.
3. ALL CONC. TO BE A MIN. OF 2500 P.S.I.
4. FIRE HYDRANT OPERATING NUTS SHALL BE OPERATED WITH SPECIAL WRENCHES FOR USE WITH NUT GUARD.
5. ALL DUCTILE IRON PIPE TO BE POLY WRAPPED PURPLE.

THIS DETAIL NEEDED ONLY ON MAINS 20" AND ABOVE, REF. URW-5 FOR ALL OTHER.

<b>MANATEE COUNTY</b>		<b>FIRE HYDRANT BLOW-OFF ASSY.</b>	<b>URW-18</b>
PUBLIC WORKS DEPARTMENT			
REV. BY	DATE		
RTH	11/99	MARCH 18, 1997	
		DATE OF APPROVAL	

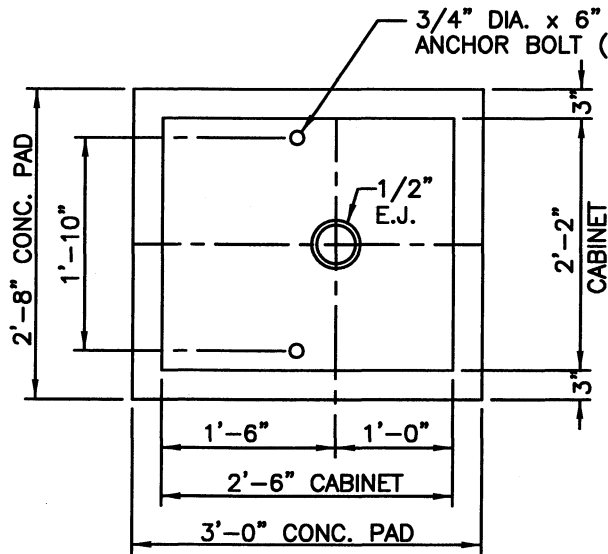

PLAN VIEW

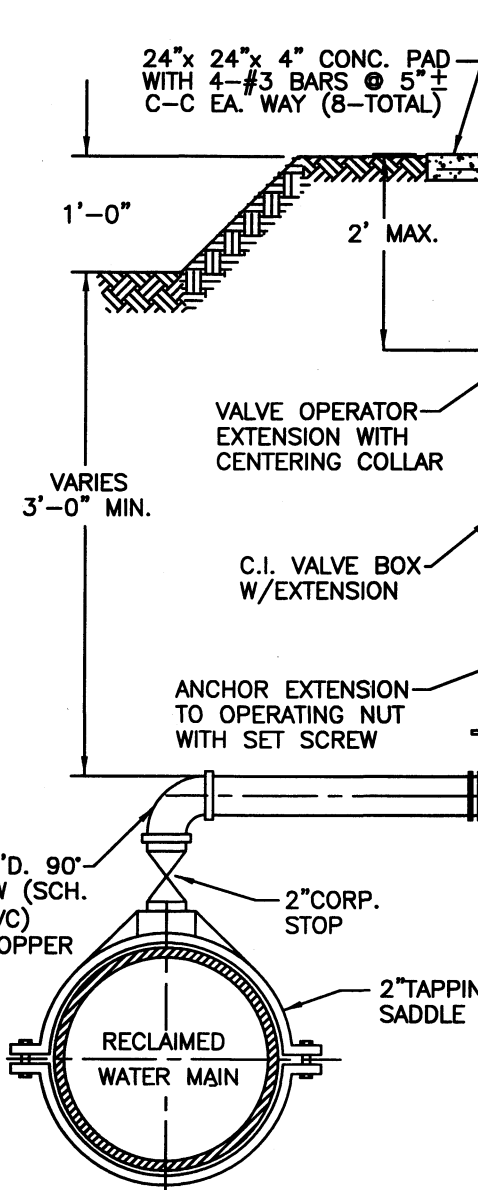
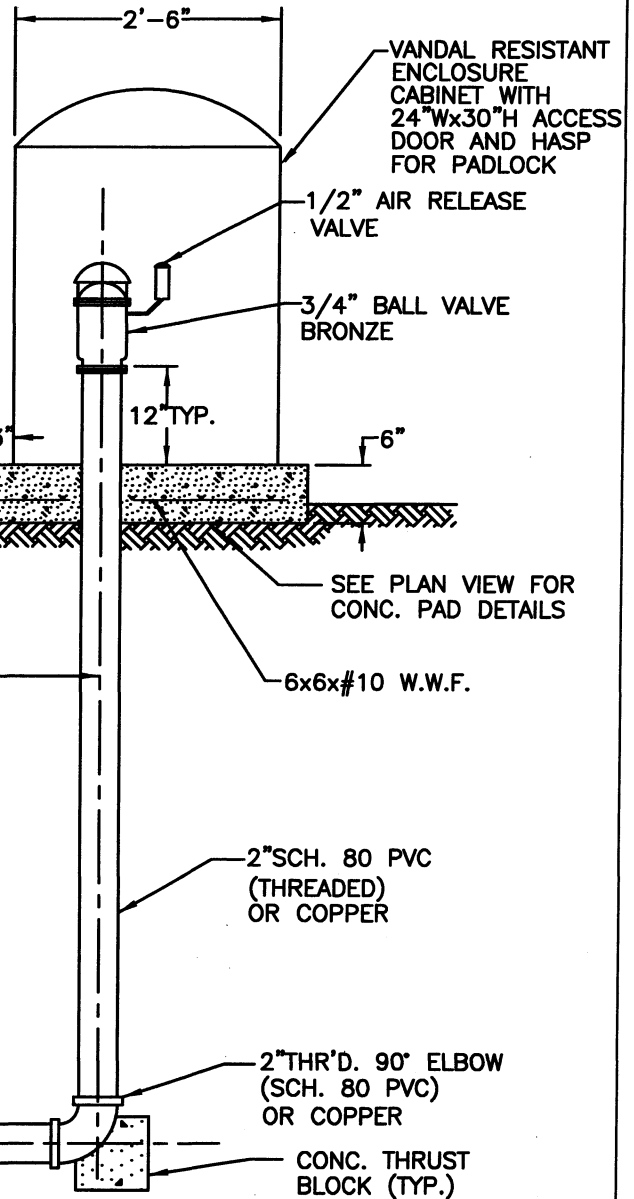

NOTE:  
ALL EXPOSED EDGES OF CONCRETE SHALL HAVE 1/2" CHAMFER.

MANATEE COUNTY  
PUBLIC WORKS DEPARTMENT

REV. BY	DATE
RTH	11/99

MARCH 18, 1997  
DATE OF APPROVAL

COMBINATION AIR/VACUUM  
& AIR RELEASE ASSY.  
FOR 18" & LARGER MAINS

URW-19

## TABLE OF CONTENTS

### UTILITY STANDARDS—RECLAIMED WATER SYSTEM

URW-0	COVER
URW-1	INTRODUCTION — MANATEE COUNTY UTILITY STANDARDS
URW-2	TABLE OF CONTENTS—RECLAIMED WATER DISTRIBUTION
URW-3	SYMBOLS—RECLAIMED WATER CONSTRUCTION
URW-4	GATE VALVE, BOX, COVER AND TAG
URW-5	TYPICAL FIRE HYDRANT ASSEMBLY
URW-6	JACK & BORE UNDER COUNTY OWNED ROADS
URW-7	CARRIER & CASING DETAIL FOR F.D.O.T. ROADS & RAILROAD CROSSINGS
URW-8	TYPICAL RECLAIMED WATER/SEWER CROSSING
URW-9	TYPICAL CANAL CROSSING
URW-10	1-1/2" & 2" METER DETAIL
URW-11	END OF LINE 2" BLOW-OFF ASSEMBLY
URW-12	4" AND LARGER BLOW-OFF ASSEMBLY
URW-13	TYPICAL RECLAIMED WATER SERVICE CONNECTION
URW-14	THRUST BLOCK DETAILS
URW-14A	RESTRAINED JOINT PIPE LENGTHS FOR PVC
URW-14B	RESTRAINED JOINT PIPE LENGTHS FOR DIP
URW-15	TAPPING SLEEVE & VALVE BLOCKING DETAIL
URW-16	SINGLE SERVICE—RECLAIMED WATER
URW-17	CUL-DE-SAC DETAIL
URW-18	FIRE HYDRANT BLOW-OFF ASSEMBLY
URW-19	COMBINATION AIR/VACUUM & AIR RELEASE ASSEMBLY FOR 18" AND LARGER MAINS
URW-20	MULTIPLE METER VAULT DETAIL
URW-21	METER YOKE DETAIL FOR 5/8"x3/4", 3/4" AND 1" METERS
URW-22	3" AND ABOVE MASTER METER DETAIL
URW-23	BELOW GRADE AIR RELEASE VALVE
URW-24	TYPICAL FIRE HYDRANT WITH LOCKED 90° BEND
URW-25	FIRE LINES 3" DIAMETER AND ABOVE BACKFLOW PREVENTER
URW-26	TRENCH DETAIL—UNIMPROVED SURFACE TYPE A-1 PIPE BEDDING
URW-27	TRENCH DETAIL—ASPHALT PAVEMENT SURFACE TYPE A-1 PIPE BEDDING
URW-28	TRENCH DETAIL—CONC. PAVEMENT SURFACE TYPE A-1 PIPE BEDDING
URW-29	TRENCH DETAIL— TYPE A-2 PIPE BEDDING
URW-30	TRENCH DETAIL— TYPE A-3 PIPE BEDDING
URW-31	DIRECTIONAL BORE ROADWAY CROSSING
URW-32	DIRECTIONAL BORE CANAL CROSSING

NOTE:

ALL RECLAIMED WATER MAINS ARE THE SAME STANDARDS AS POTABLE WATER, EXCEPT FOR COLOR CODING WHICH WILL BE PURPLE (PANTONE 522C). WHEN INSTALLING RECLAIMED MAINS PARALLEL WITH POTABLE WATER LINES, OR SANITARY SEWER LINES, A MINIMUM OF FIVE FEET HORIZONTAL SEPARATION (CENTER TO CENTER) AND THREE FEET (OUTSIDE TO OUTSIDE) IS REQUIRED. WATER WORKS SHALL BE DESIGNED IN ACCORDANCE WITH F.D.E.P. REGULATIONS AND "RECOMMENDED STANDARDS FOR WATER WORKS" BY THE GREAT LAKES—UPPER MISSISSIPPI BOARD OF STATE PUBLIC HEALTH AND ENVIRONMENTAL MANAGERS.

MANATEE COUNTY PUBLIC WORKS DEPARTMENT		TABLE OF CONTENTS RECLAIMED WATER DISTRIBUTION	URW-2
REV. BY	DATE		
RTH	11/99		
MARCH 18, 1997 <hr style="width: 50%; margin: auto;"/> DATE OF APPROVAL			

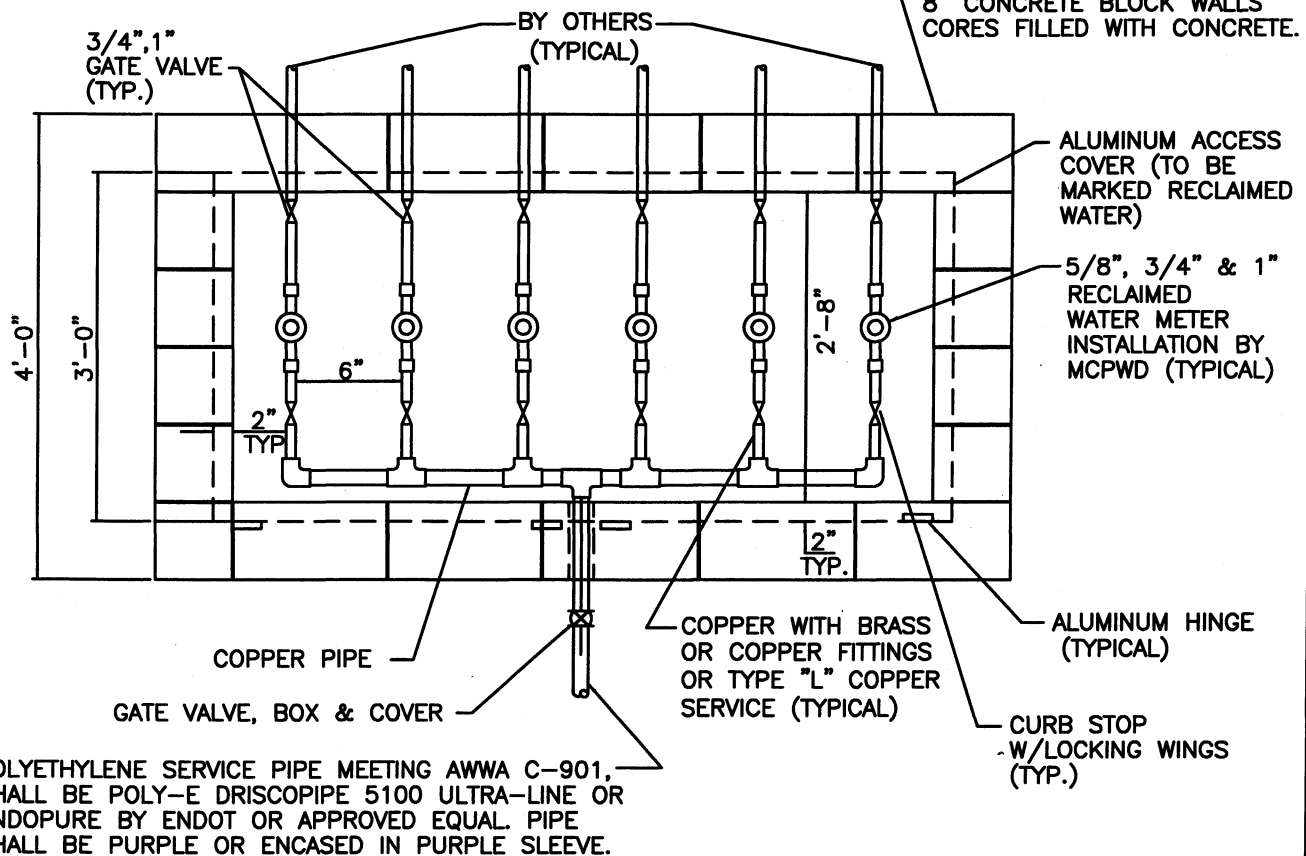
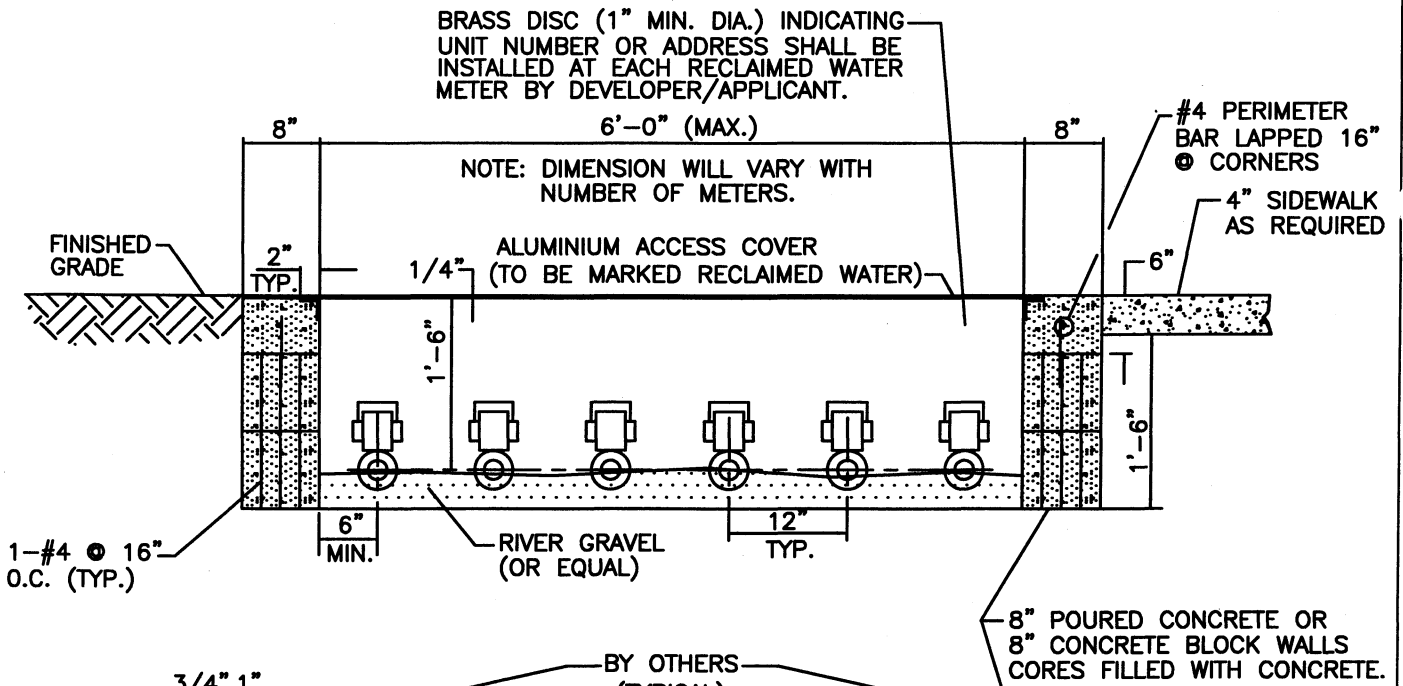

**NOTES:**

1. SEE DETAIL UW-10A FOR BACKFLOW PREVENTERS THAT MAY BE REQUIRED DOWN STREAM OF THE METERS.
2. ALUMINIUM ACCESS COVER SHALL HAVE RECESSED LIFTING HANDLES AND BE CAPABLE OF SUPPORTING A SUPER-IMPOSED LOAD OF 75 P.S.F.

MANATEE COUNTY PUBLIC WORKS DEPARTMENT		MARCH 18, 1997 DATE OF APPROVAL	MULTIPLE RECLAIMED WATER METER VAULT DETAIL	URW-20
REV. BY RTH	DATE 11/99			

CAST IRON OVAL METER BOX, 19"L x 10"D  
 ROME 1910 OR APPROVED EQUAL  
 EPOXY PAINTED PURPLE AND  
 MARKED RECLAIMED WATER

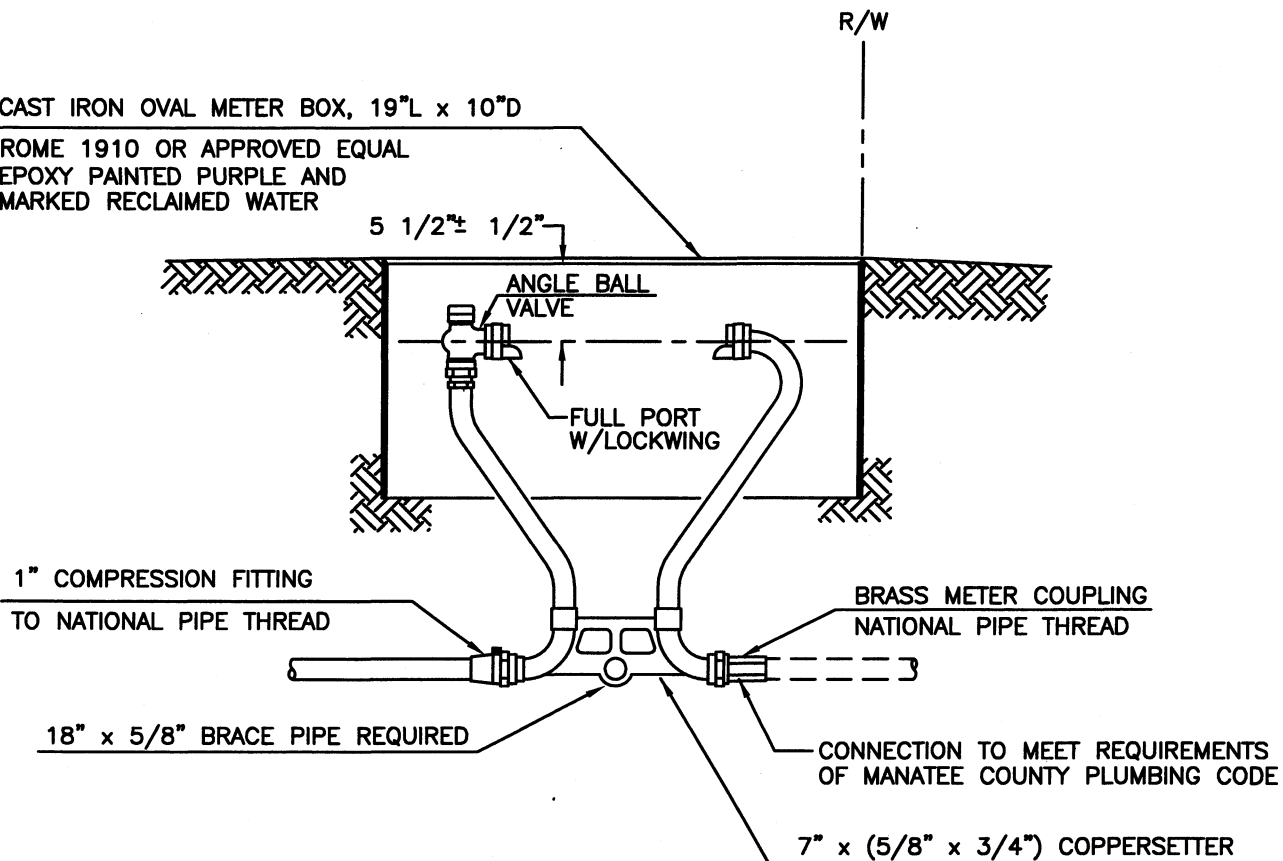

**NOTES:**

1. REFERENCE URW-13 FOR COMPLETE SERVICE CONNECTION ASSEMBLY.
2. FORD 70 SERIES, MUELLER B-2434 OR APPROVED EQUAL. COPPER INLET W/ANGLE BALL VALVE, FIP OUTLET MIN. 7" HGT. ALL VALVES SHALL BE FULL PORT 5/8"x 3/4", OR 3/4" OR 1" METERS. (CHECK VALVES SHOULD NOT BE USED)
3. METER BOX AND YOKE ARE TO BE INSTALLED BY THE INFRASTRUCTURE CONTRACTOR AND SHALL NOT BE SET IN DRAINAGE SWALES, EASEMENTS, SIDEWALKS OR DRIVEWAYS.

7" x (5/8" x 3/4") COPPERSETTER  
 FORD 70 SERIES, MUELLER  
 B-2434 OR APPROVED EQUAL.  
 LOCKING CAMS ON CURB STOP

MANATEE COUNTY  
 PUBLIC WORKS DEPARTMENT

COPPER METER YOKE  
 DETAIL FOR  
 5/8" x 3/4",  
 3/4" & 1" METERS

URW-21

REV. BY	DATE
RTH	11/99

MARCH 18, 1997  
 DATE OF APPROVAL

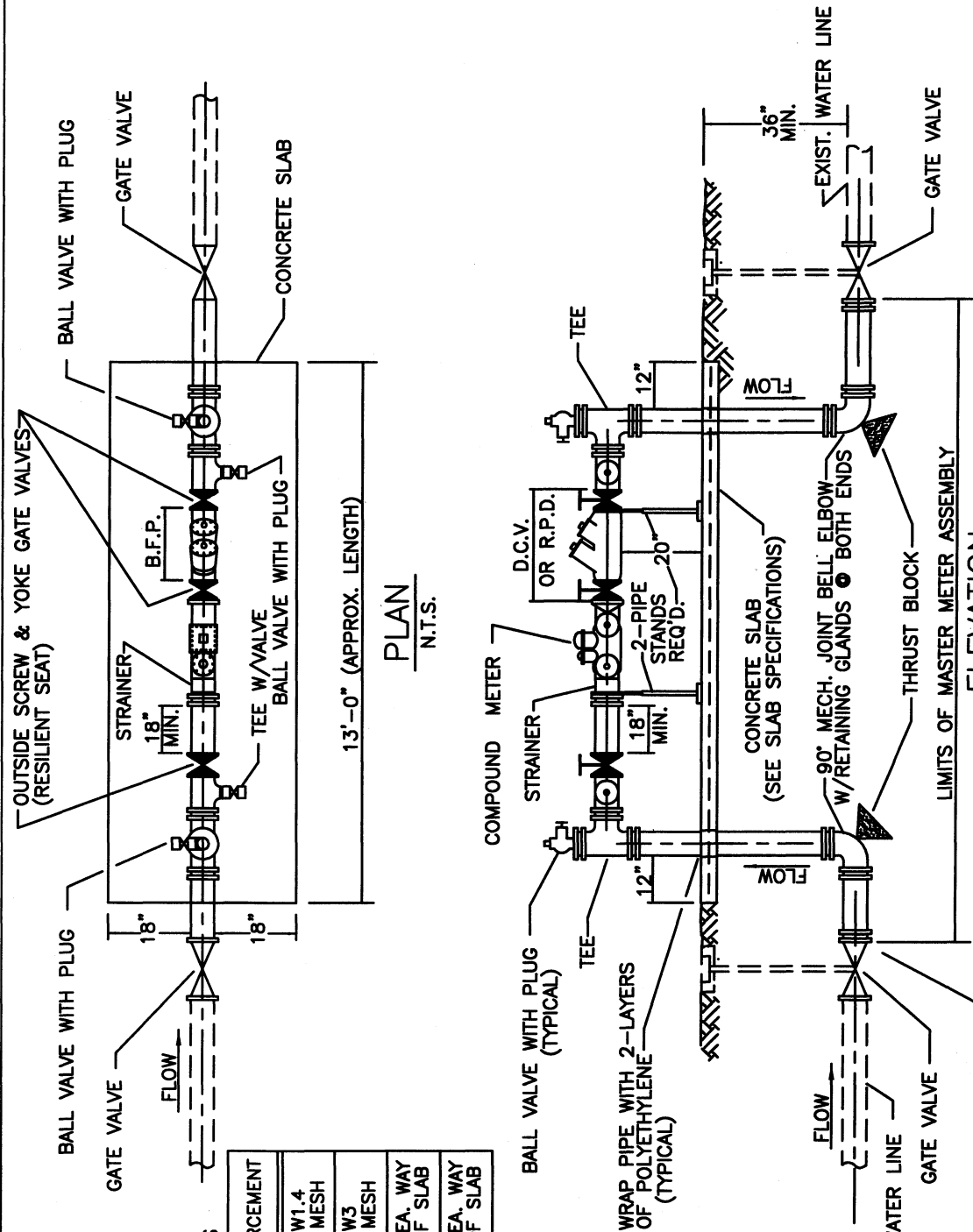

SLAB SPECIFICATIONS

PIPE DIAMETER	SLAB THICKNESS	REINFORCEMENT
3" TO 10"	4"	6x6 W1.4 WIRE MESH
12" TO 18"	4"	6x6 W3 WIRE MESH
20" TO 36"	5 1/2"	#309" EA. WAY @ 6" OF SLAB
42" TO 48"	7 1/2"	#309" EA. WAY @ 6" OF SLAB

PLAN  
N.T.S.

ELEVATION  
N.T.S.

NOTES:

1. ABOVE GROUND PIPING TO BE PAINTED PURPLE WITH NON-POTABLE MARKINGS.
2. DEVICES MUST BE INSTALLED LEVEL.
3. ALL JOINTS SHALL BE FLANGED UNLESS OTHERWISE NOTED.
4. ◀ DENOTES OUTSIDE SCREW & YOKE GATE VALVE.
5. ALL BELOW GROUND D.I. PIPE AND FITTINGS SHALL BE POLYETHYLENE WRAPPED.
6. BACKFLOW PREVENTER ONLY IF REQUIRED TO PREVENT CONTAMINATION BY ATTACHED CHEMICAL/FERTILIZER INJECTION METHODS.
7. ALL EXPOSED CONCRETE EDGES SHALL HAVE 1/2" CHAMFER.

MANATEE COUNTY  
PUBLIC WORKS DEPARTMENT

REV. BY	DATE
RTH	11/99

MARCH 18, 1997  
DATE OF APPROVAL

3" AND ABOVE  
MASTER METER DETAIL

URW-22



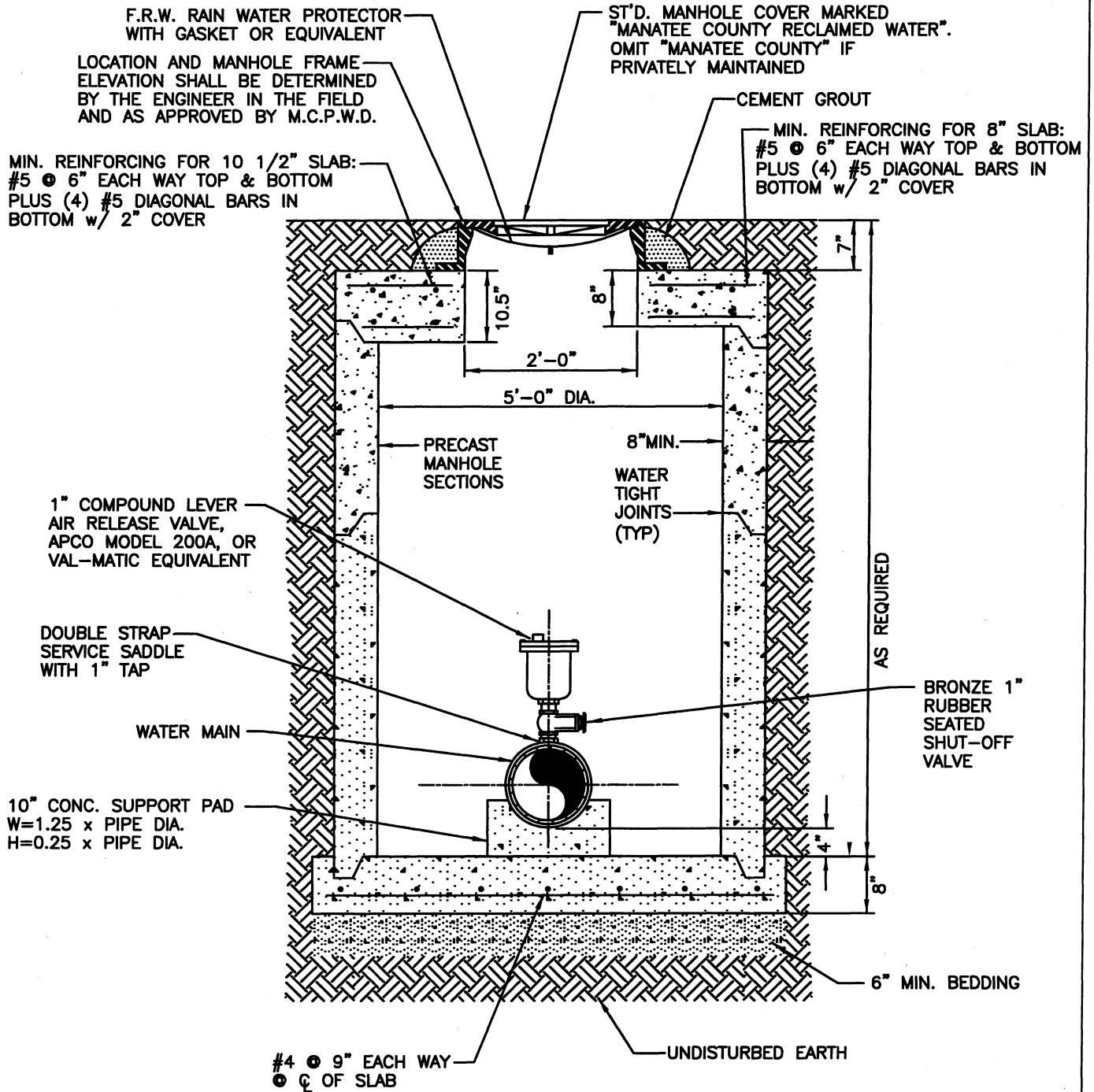

**NOTES:**

- 1.) WHEREVER POSSIBLE AIR RELEASE VALVES SHALL BE PLACED ABOVE GROUND IN STAINLESS STEEL CABINET.
- 2.) ALL PIPE STUBS, NIPPLES AND HARDWARE TO BE 304 STAINLESS STEEL
- 3.) TO PREVENT DAMAGE TO VALVE FROM TIPPED MANHOLE COVERS IN SHALLOW BOXES IT MAY BE NECESSARY TO OFFSET VALVE FROM CENTERLINE.
- 4.) AIR RELEASE VALVES TO BE INSTALLED AT HIGH POINTS OF MAIN AS DIRECTED BY THE ENGINEER.
- 5.) ALL PIPE APPURTENANCES AND SIZING IN ACCORDANCE WITH SPECIFIC DEVICE APPLICATION.
- 6.) WHERE AIR RELEASE VALVE IS 12' OR FURTHER FROM CURB OR SHOULDER OF ROADWAY SERIES H1R3030 ACCESS DOOR OR APPROVED EQUAL MAY BE USED.

MANATEE COUNTY PUBLIC WORKS DEPARTMENT		MARCH 18, 1997 DATE OF APPROVAL	BELOW GRADE AIR RELEASE VALVE	URW-23
REV. BY	DATE			
RTH	11/99			

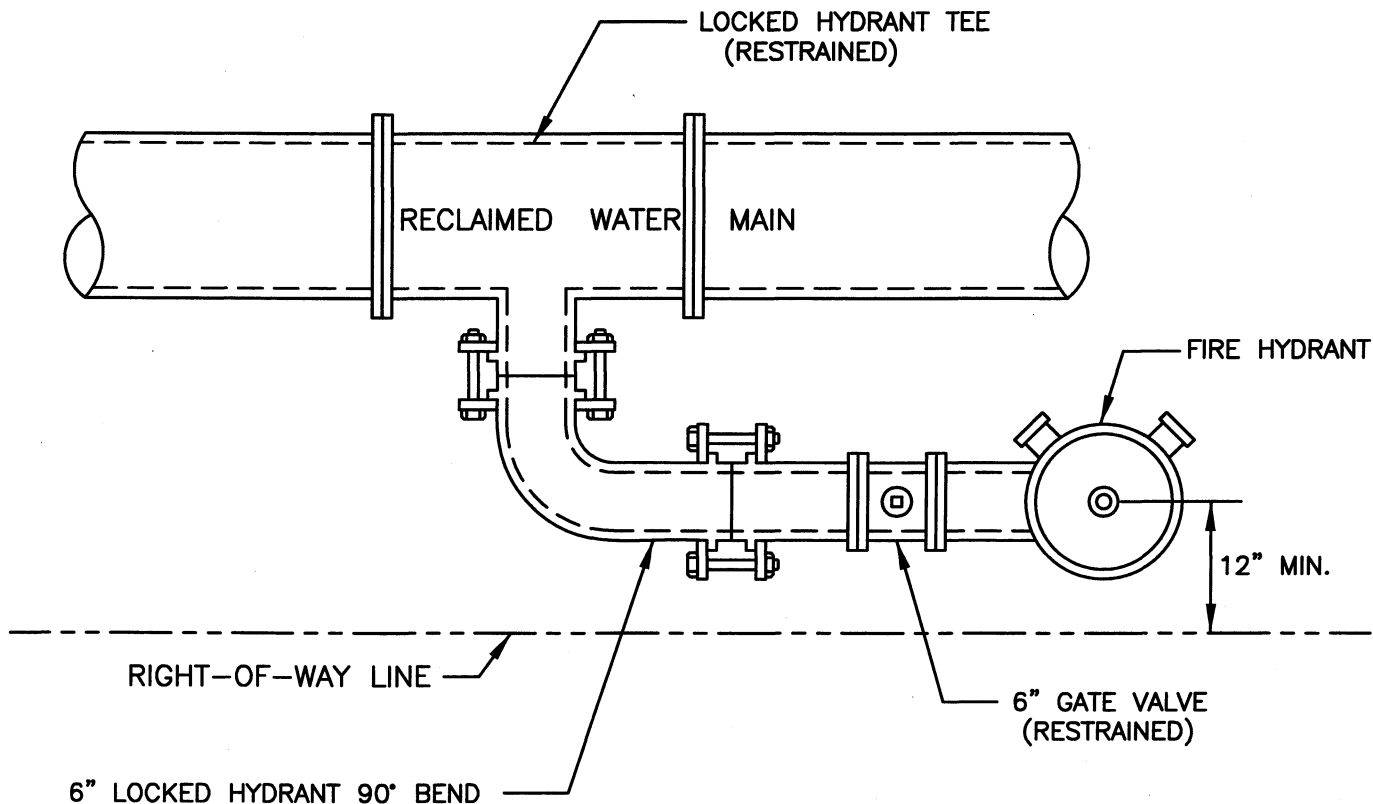

PLAN

NOTE:

THIS DETAIL FOR USE ONLY WHEN THE RECLAIMED WATER MAIN IS LOCATED TOO CLOSE TO THE RIGHT-OF-WAY LINE TO USE DETAIL URW-5.

<b>MANATEE COUNTY</b> PUBLIC WORKS DEPARTMENT		TYPICAL FIRE HYDRANT WITH LOCKED 90° BEND	URW-24
REV. BY	DATE		
MARCH 18, 1997 DATE OF APPROVAL			

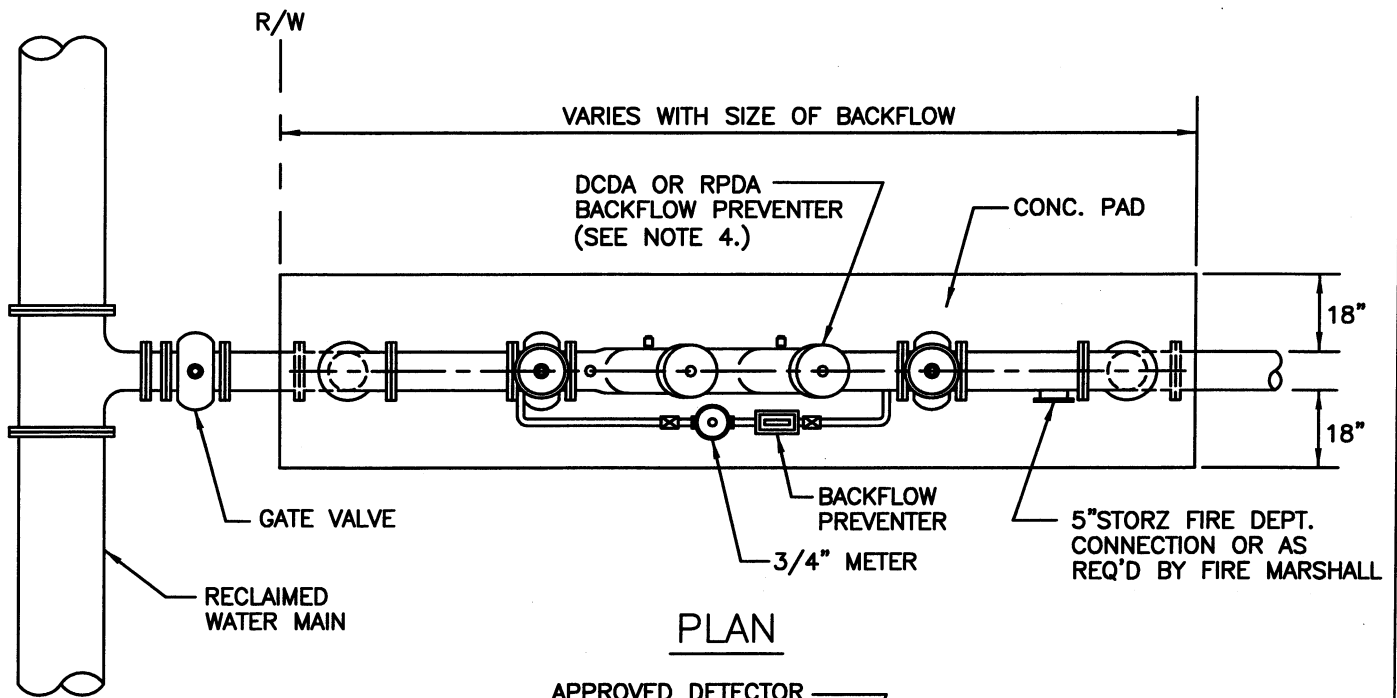

PLAN

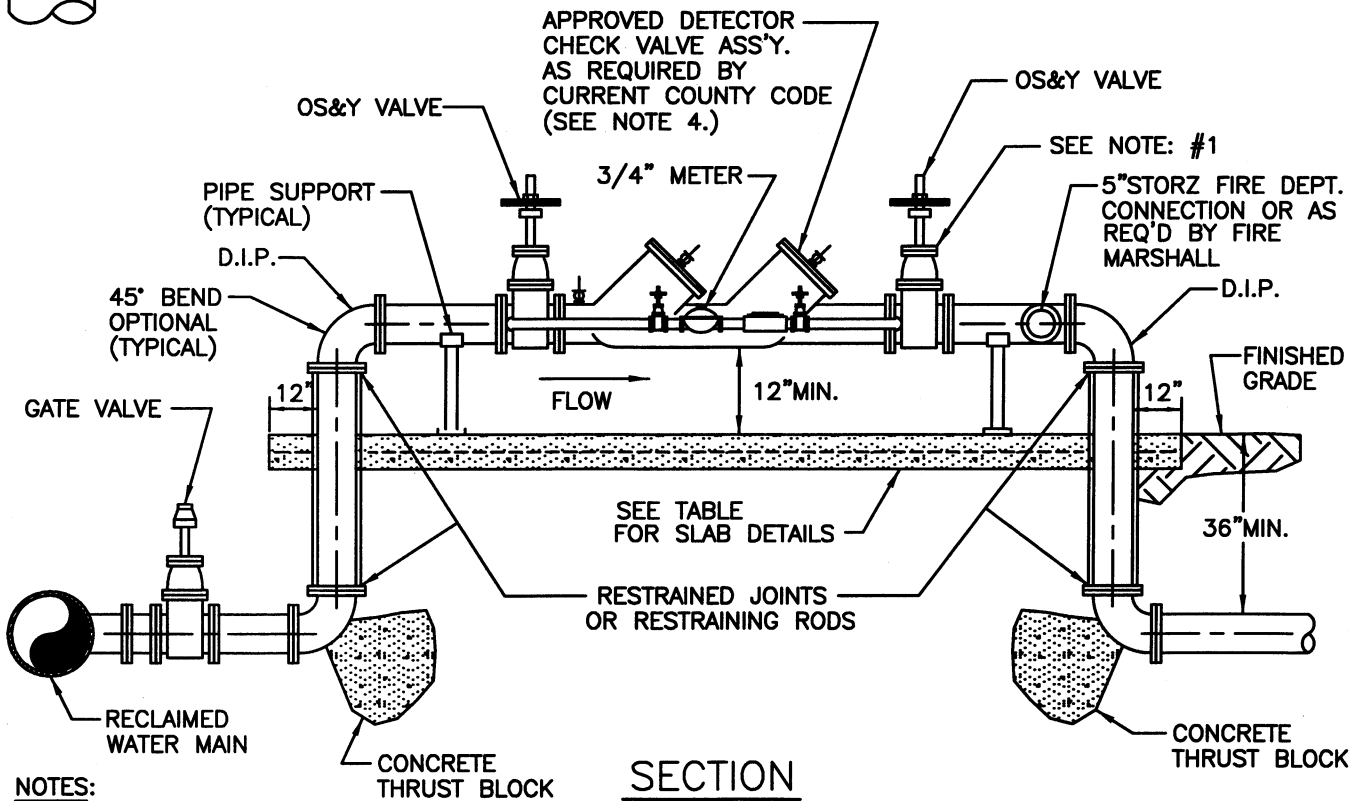

SECTION

NOTES:

1. WHEN PRESSURE TESTING FIRE LINE, TEST AGAINST DOWNSTREAM GATE VALVE.
2. THE SYSTEM MUST MEET ALL REQUIREMENTS OF THE MANATEE COUNTY PLUMBING CODE (LATEST EDITION) AND THE MANATEE COUNTY BACKFLOW PREVENTION CODE (LATEST EDITION) AND THE MANATEE COUNTY FIRE MARSHALL REQUIREMENTS.
3. PAINT PURPLE AND PROVIDE NON-POTABLE SIGN
4. BACKFLOW PREVENTER AS REQUIRED TO PREVENT CONTAMINATION OF RECLAIM SYSTEM.
5. ALL EXPOSED EDGES OF CONCRETE SHALL HAVE 1/2" CHAMFER.

SLAB DETAILS

PIPE DIAMETER	SLAB THICKNESS	REINFORCEMENT
3" TO 10"	4"	6x6 W1.4 WIRE MESH
12" TO 18"	5"	6x6 W3 WIRE MESH

MANATEE COUNTY  
PUBLIC WORKS DEPARTMENT

REV. BY	DATE
RTH	11/99

MARCH 18, 1997  
DATE OF APPROVAL

3" AND ABOVE FIRE LINES  
BACKFLOW PREVENTER

URW-25

**NOTES:**

- 1.) USE OF TYPE A-2 AND A-3 PIPE BEDDING TO BE DETERMINED IN THE FIELD BY THE ENGINEER.
- 2.) 10" MAX. FOR PIPE DIAMETER LESS THAN 24"; 12" MAX. FOR PIPE DIAMETER 24" AND LESS THAN 42"; 24" MAX. FOR PIPE DIAMETER 42" AND OVER.
- 3.) 4" MAX. FOR PIPE 16" DIAMETER & LESS; 6" MAX. FOR PIPE 18" TO 36" DIAMETER; AND 9" MAX FOR PIPE 42" DIAMETER AND LARGER.
- 4.) INSTALLATION SHALL BE IN ACCORDANCE WITH THE MANUFACTURER'S SPECIFICATIONS.

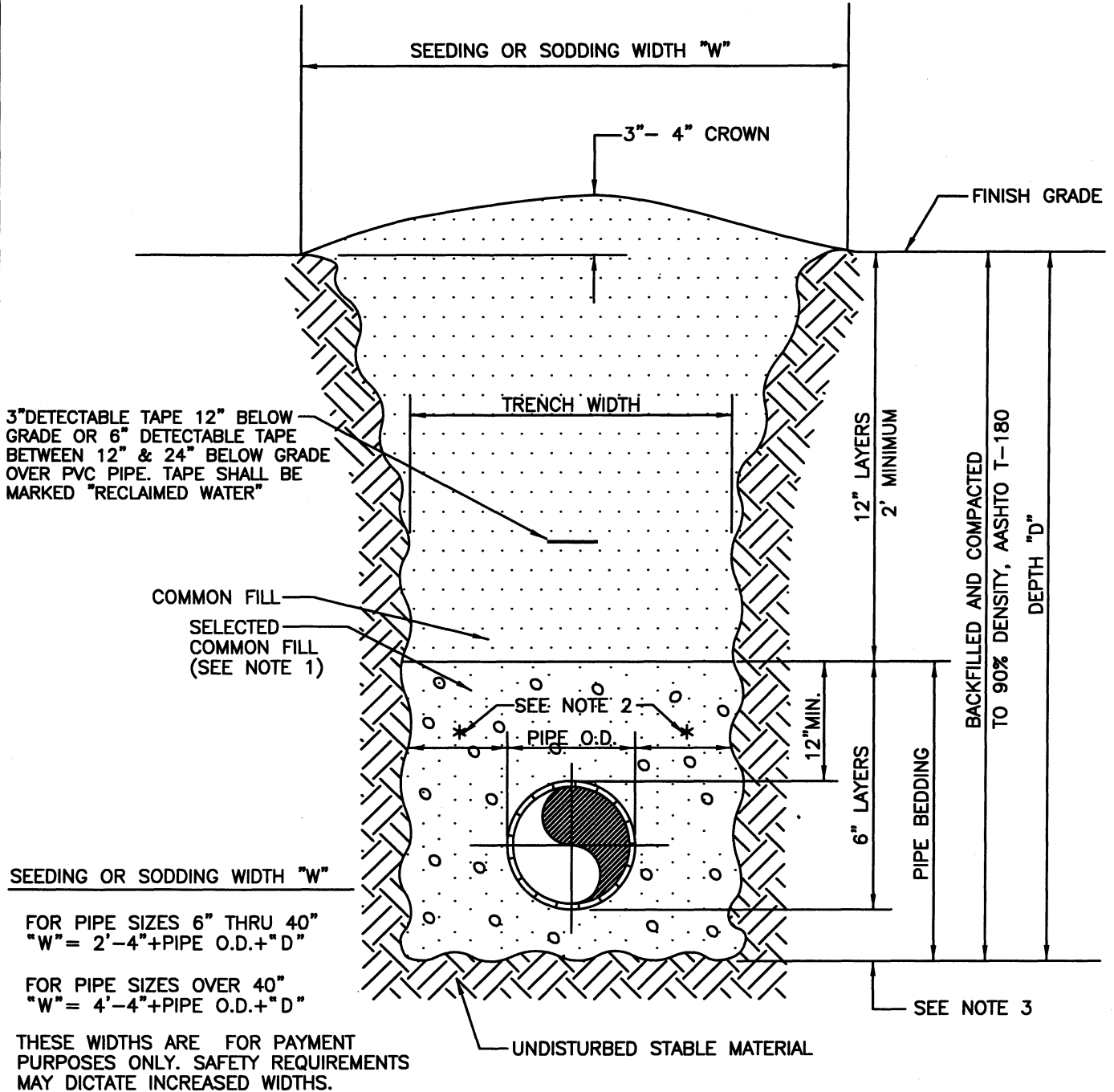

MANATEE COUNTY  
PUBLIC WORKS DEPARTMENT

TRENCH DETAIL  
UNIMPROVED SURFACE  
TYPE A-1 PIPE BEDDING

URW-26

REV. BY	DATE
RTH	11/99

MARCH 18, 1997  
DATE OF APPROVAL

**NOTES:**

- 1.) USE OF TYPE A-2 AND A-3 PIPE BEDDING TO BE DETERMINED IN THE FIELD BY THE ENGINEER.
- 2.) 10" MAX. FOR PIPE DIAMETERS LESS THAN 24"; 12" MAX. FOR PIPE DIAMETER 24" AND LESS THAN 42"; 24" MAX. FOR PIPE DIAMETER 42" AND OVER.
- 3.) 4" MAX. FOR PIPE 16" DIAMETER & LESS; 6" MAX. FOR PIPE 18" TO 36" DIAMETER; AND 9" MAX. FOR PIPE 42" DIAMETER AND LARGER.
- 4.) INSTALLATION SHALL BE IN ACCORDANCE WITH THE MANUFACTURER'S SPECIFICATIONS.
- 5.) WEARING SURFACE TO BE SAME TYPE & THICKNESS (1½" MIN.) AS EXISTING PAVEMENT.
- 6.) SHEETING ORDERED LEFT IN PLACE TO BE CUT OFF 24" BELOW FINISHED GRADE OR 12" BELOW SUBGRADE.
- 7.) BASE SHALL BE 6" MINIMUM THICKNESS SAND ASPHALT, 10" MIN. THICKNESS CRUSHED CONCRETE, OR APPROVED EQUAL.
- 8.) BACKFILL AASHTO M-145 SHALL BE PLACED IN LAYERS NOT TO EXCEED 6 INCHES. EACH LAYER SHALL BE THOROUGHLY TAMPED AND/OR ROLLED TO 98% AASHTO T-180 DENSITY.
- 9.) TEMPORARY PATCHES WILL BE INSTALLED TO PROVIDE A SMOOTH ALL WEATHER SURFACE AT ALL TIMES. PERMANENT REPLACEMENT TO BE MADE AS SOON AS POSSIBLE.
- 10.) NOTES 5.) THRU 9.) ARE MINIMUM REQUIREMENTS. REFER TO MANATEE COUNTY TRANSPORTATION DEPARTMENT FOR ADDITIONAL REQUIREMENTS.

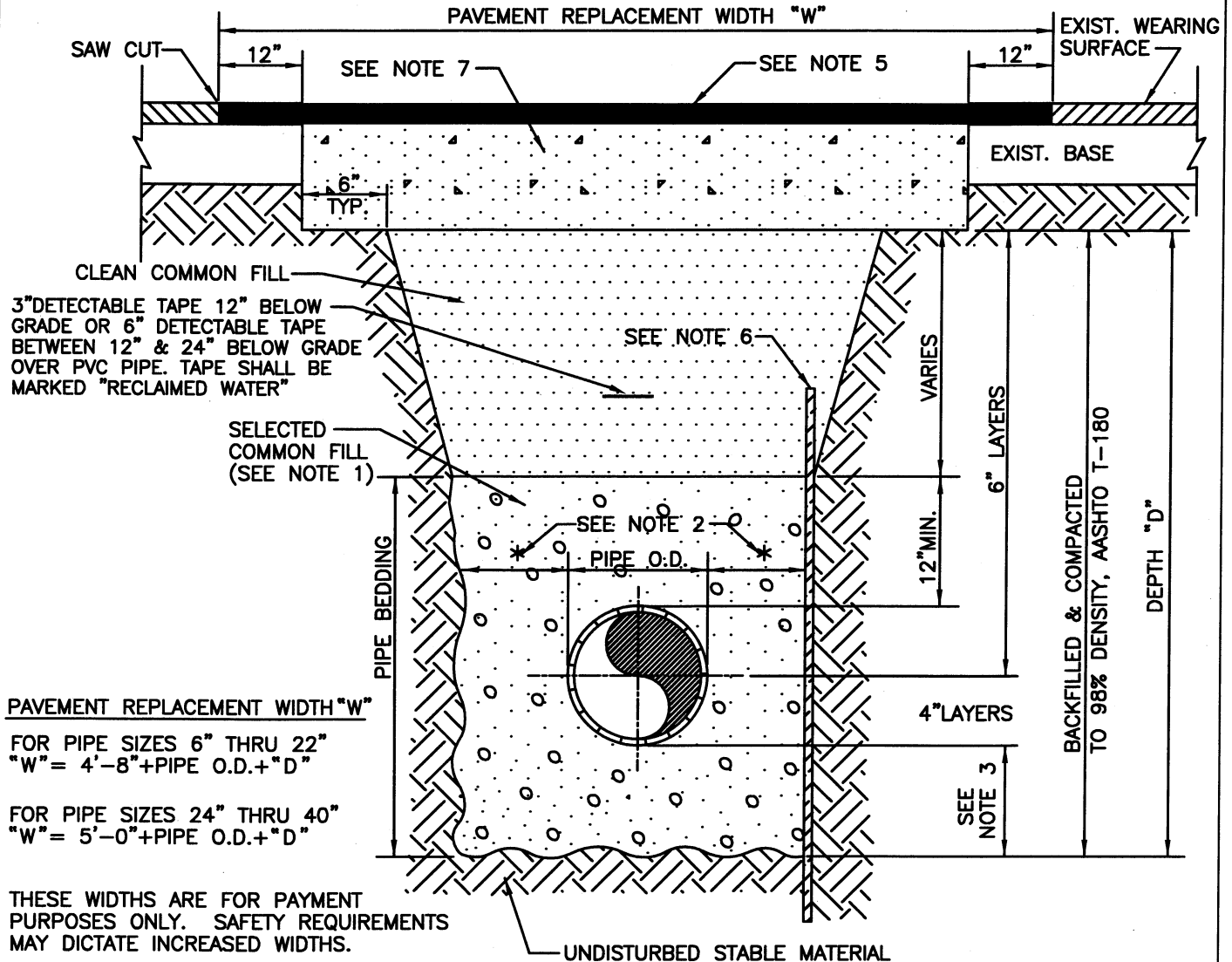

MANATEE COUNTY  
PUBLIC WORKS DEPARTMENT

TRENCH DETAIL

ASPH. PAVEMENT SURFACE  
TYPE A-1 PIPE BEDDING

URW-27

REV. BY	DATE
RTH	11/99

MARCH 18, 1997  
DATE OF APPROVAL

NOTES:

- 1.) USE OF TYPE A-2 AND A-3 PIPE BEDDING TO BE DETERMINED IN THE FIELD BY THE ENGINEER.
- 2.) 10" MAX. FOR PIPE DIAMETER LESS THAN 24"; 12" MAX. FOR PIPE DIAMETER 24" AND LESS THAN 42"; 24" MAX. FOR PIPE DIAMETER 42" AND OVER.
- 3.) 4" MAX. FOR PIPE 16" DIAMETER & LESS; 6" MAX. FOR PIPE 18" TO 36" DIAMETER; AND 9" MAX. FOR PIPE 42" DIAMETER AND LARGER.
- 4.) INSTALLATION SHALL BE IN ACCORDANCE WITH THE MANUFACTURER'S SPECIFICATIONS.
- 5.) THICKNESS TO MATCH EXISTING OR BE 8" MINIMUM, WHICHEVER IS GREATER.

FOR NOTES 6.) THRU 10.) SEE URW-27

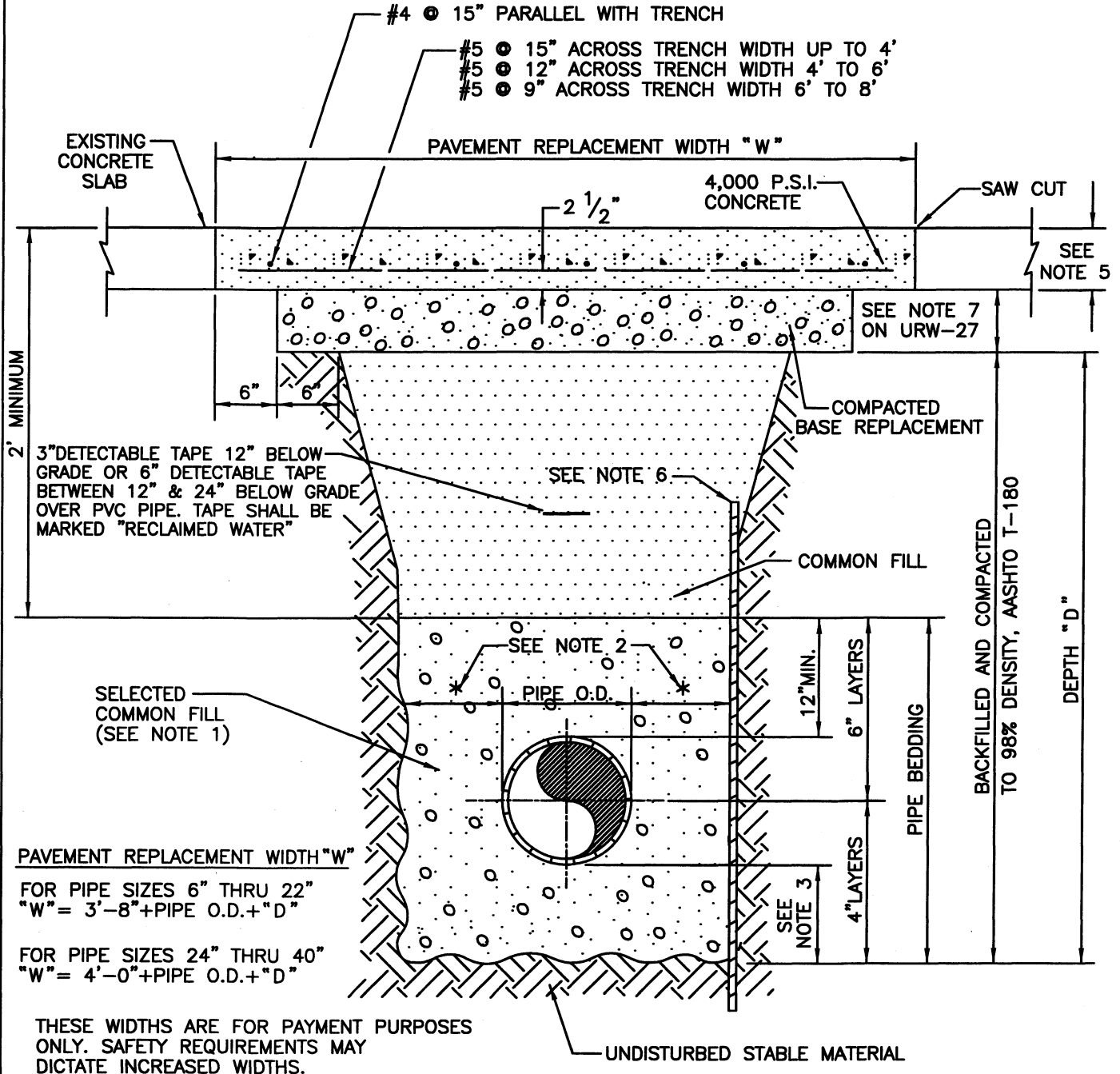

MANATEE COUNTY  
PUBLIC WORKS DEPARTMENT

REV. BY	DATE
RTH	11/99

MARCH 18, 1997  
DATE OF APPROVAL

TRENCH DETAIL  
CONC. PAVEMENT SURFACE  
TYPE A-1 PIPE BEDDING

URW-28

NOTES:

- 1.) 10" MAX. FOR PIPE DIAMETER LESS THAN 24"; 12" MAX. FOR PIPE DIAMETER 24" AND LESS THAN 42"; 24" MAX. FOR PIPE DIAMETER 42" AND OVER.
- 2.) 4" MAX. FOR PIPE 16" DIAMETER AND LESS; 6" MAX. FOR PIPE DIAMETER 18" TO 36" AND 9" MAX. FOR PIPE DIAMETER 42" AND OVER.
- 3.) INSTALLATION SHALL BE IN ACCORDANCE WITH THE MANUFACTURER'S SPECIFICATIONS.

3" DETECTABLE TAPE 12" BELOW GRADE OR 6" DETECTABLE TAPE BETWEEN 12" & 24" BELOW GRADE OVER PVC PIPE. TAPE SHALL BE MARKED "RECLAIMED WATER"

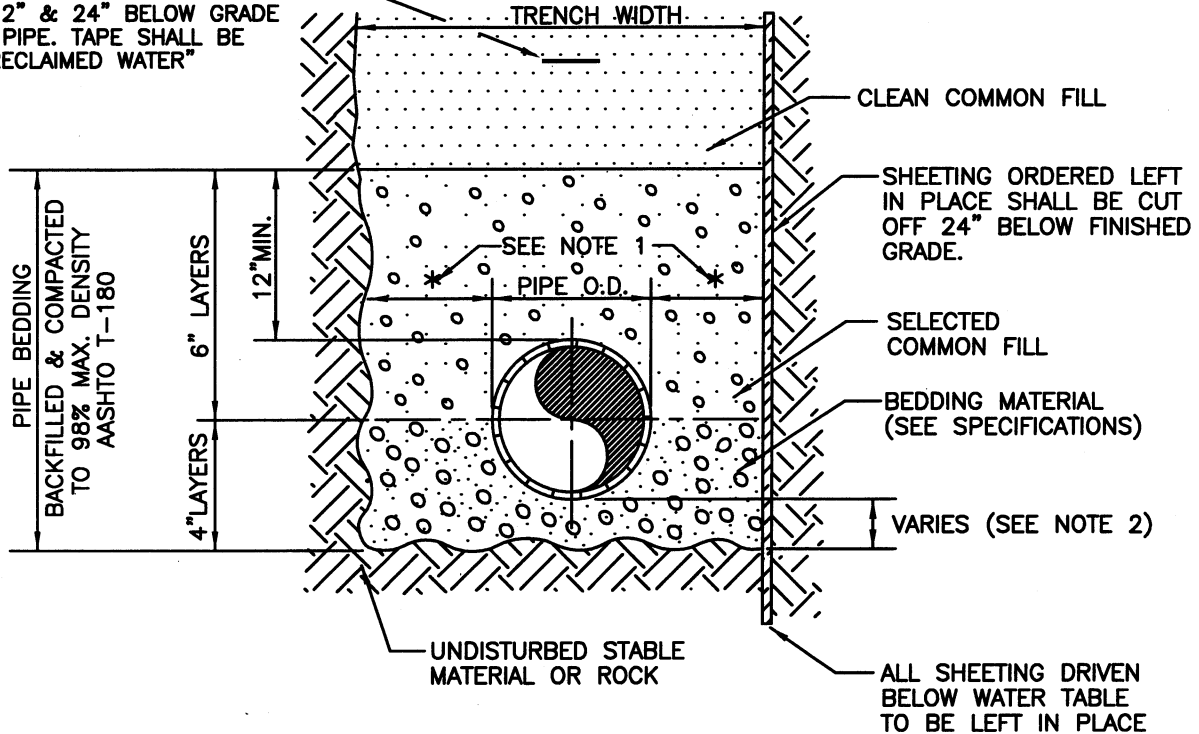

MANATEE COUNTY  
PUBLIC WORKS DEPARTMENT

TRENCH DETAIL

URW-29

REV. BY	DATE
RTH	11/99

MARCH 18, 1997  
DATE OF APPROVAL

TYPE A-2 PIPE BEDDING

	RECLAIMED WATER MAIN (PROPOSED)
	RECLAIMED WATER MAIN (EXISTING)
	PLUG/CAP
	BLOW-OFF
	GATE VALVE (PROPOSED)
	GATE VALVE (EXISTING)
	BUTTERFLY VALVE
	CHECK VALVE, CLAPPER TYPE
	CHECK VALVE, REDUCED PRESSURE
	REDUCER FITTING
	PRESSURE REGULATOR
	FITTING WITH THRUST BLOCK
	RECLAIMED FIRE HYDRANT (EXISTING)
	RECLAIMED FIRE HYDRANT ASSEMBLY (PROPOSED)
	SINGLE SERVICE RECLAIMED WATER METER (PROPOSED)
	SINGLE SERVICE RECLAIMED WATER METER (EXISTING)
	DOUBLE SERVICE RECLAIMED WATER METER (PROPOSED)
	GANG RECLAIMED WATER METER ASSEMBLY (PROPOSED)
	MANHOLE (PROPOSED)

MANATEE COUNTY PUBLIC WORKS DEPARTMENT		SYMBOLS RECLAIMED WATER CONSTRUCTION	URW-3
REV. BY	DATE		
	MARCH 18, 1997		
	DATE OF APPROVAL		



**NOTES:**

- 1.) 10" MAX. FOR PIPE DIAMETER LESS THAN 24"; 12" MAX. FOR PIPE DIAMETER 24" AND LESS THAN 42"; 24" MAX. FOR PIPE DIAMETER 42" AND OVER.
- 2.) 4" MAX. FOR PIPE 16" DIAMETER & LESS; 6" MAX. FOR PIPE 18" TO 36" DIAMETER; AND 9" MAX FOR PIPE 42" DIAMETER AND LARGER.
- 3.) INSTALLATION SHALL BE IN ACCORDANCE WITH THE MANUFACTURER'S SPECIFICATIONS.

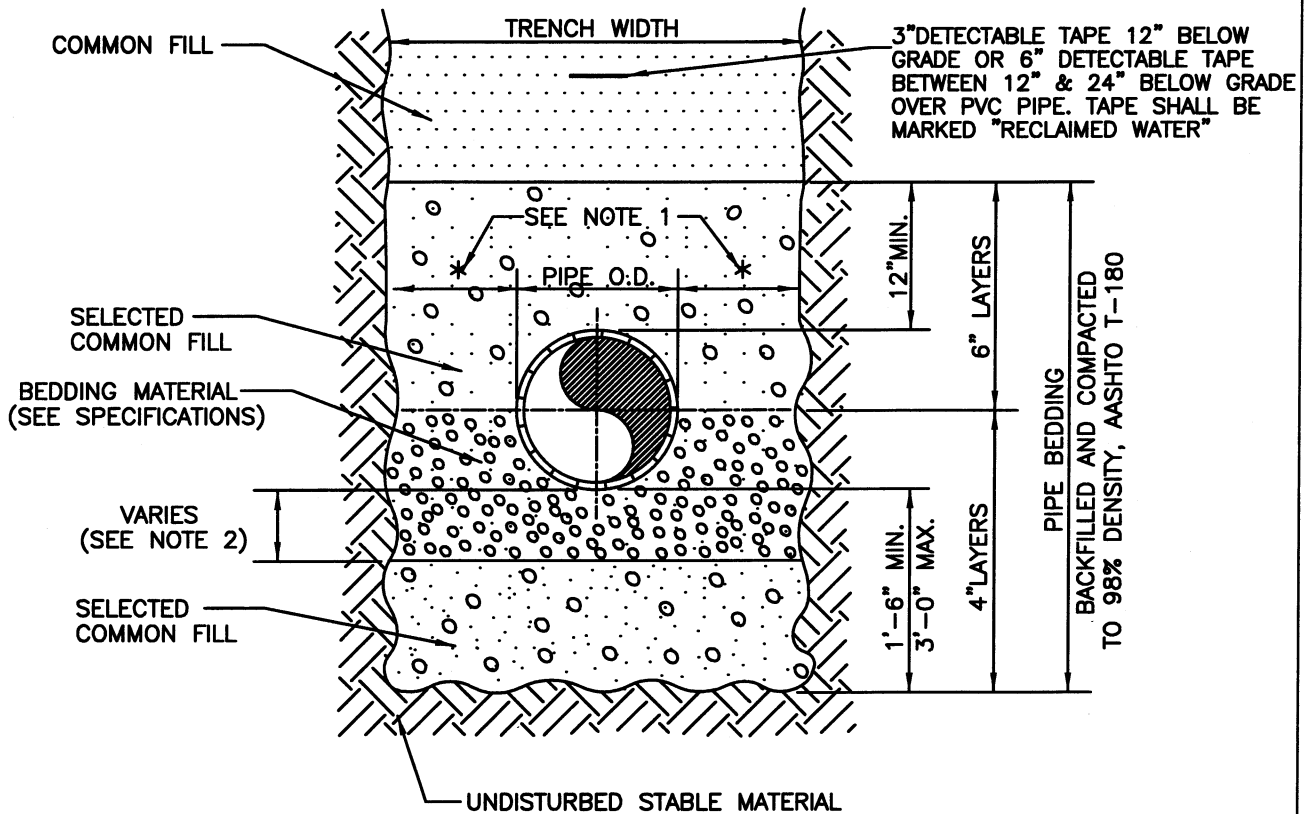

MANATEE COUNTY  
PUBLIC WORKS DEPARTMENT

REV. BY	DATE
RTH	11/99

MARCH 18, 1997  
DATE OF APPROVAL

TRENCH DETAIL  
TYPE A-3 PIPE BEDDING

URW-30

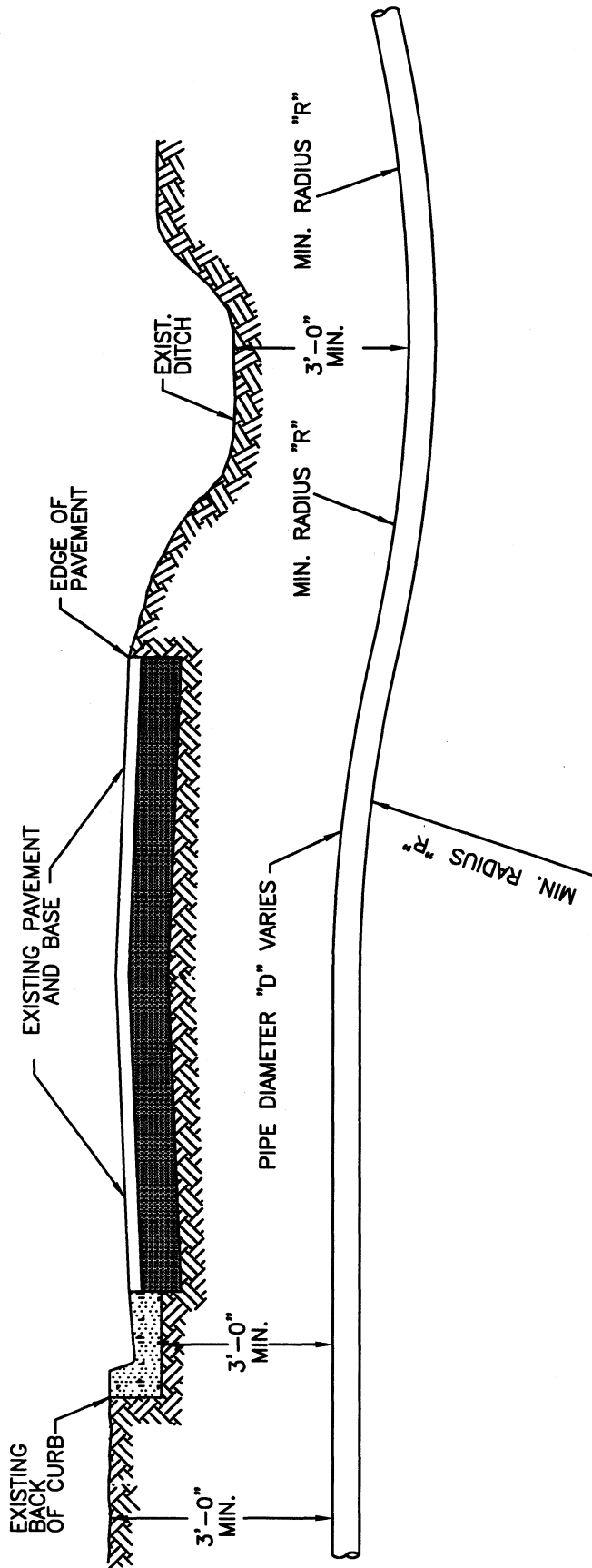

PIPE DIAMETER "D" IN INCHES	MIN. RADIUS FOR PE PIPE IN FEET	
	MIN. RADIUS "R" FOR SDR-11	MIN. RADIUS "R" FOR SDR-9
2	4	5.5
3	6	8.3
4	8	11.0
6	12	16.5
8	16	22.0
10	20	27.5
12	24	33.0
16	32	44.0
18	36	49.5
20	40	55.0

ALL POLYETHYLENE PIPING SHALL MEET MANATEE COUNTY STANDARDS AND SPECIFICATIONS

SDR-9, CLASS 200 FOR POTABLE WATER & RECLAIMED WATER  
 SDR-11, CLASS 160 FOR SANITARY FORCE MAINS  
 COLOR CODED BLUE FOR POTABLE WATER  
 COLOR CODED PURPLE FOR RECLAIMED WATER  
 COLOR CODED GREEN FOR SANITARY FORCE MAIN

MANATEE COUNTY  
 PUBLIC WORKS DEPARTMENT

REV. BY	DATE

NOVEMBER 1, 1999  
 DATE OF APPROVAL

DIRECTIONAL BORE  
 ROADWAY CROSSING

URW-31

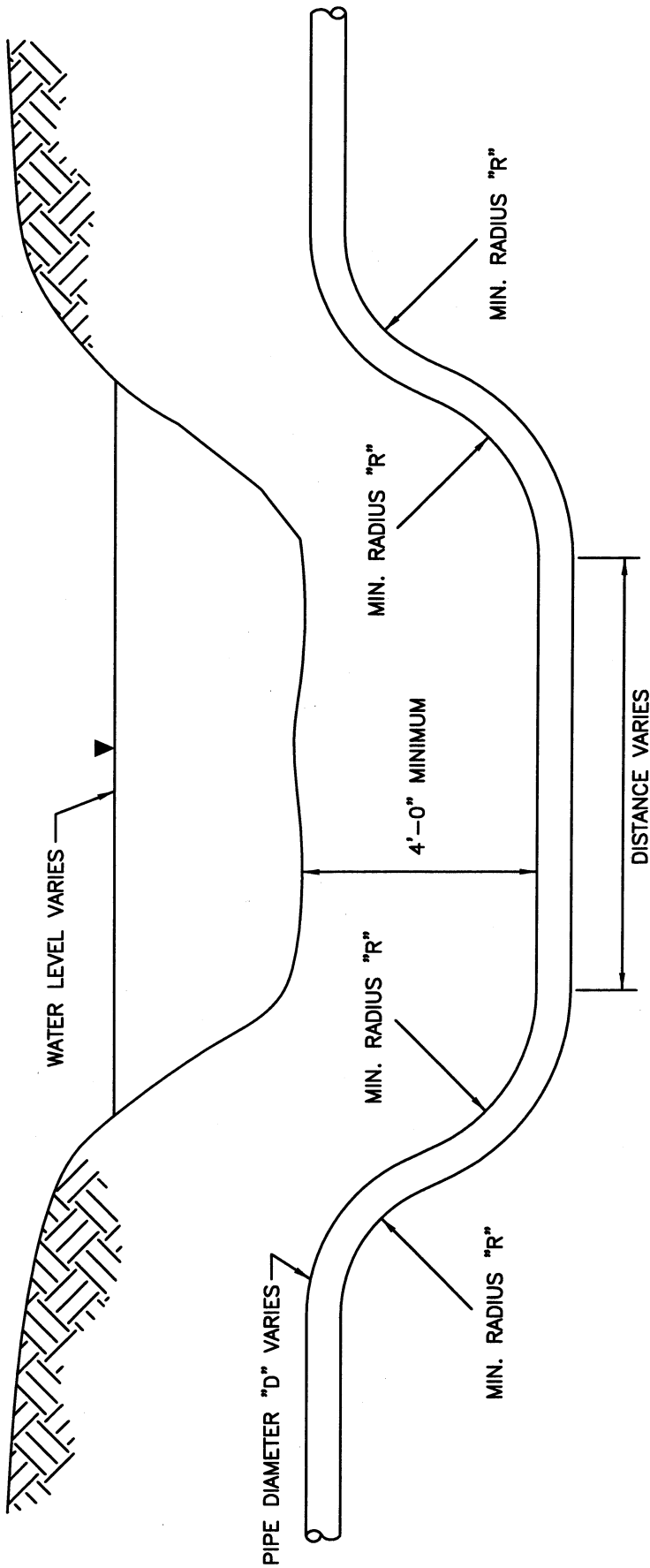

ALL POLYETHYLENE PIPING SHALL MEET MANATEE COUNTY STANDARDS AND SPECIFICATIONS

SDR-9, CLASS 200 FOR POTABLE WATER & RECLAIMED WATER  
 SDR-11, CLASS 160 FOR SANITARY FORCE MAINS  
 COLOR CODED BLUE FOR POTABLE WATER  
 COLOR CODED PURPLE FOR RECLAIMED WATER  
 COLOR CODED GREEN FOR SANITARY FORCE MAIN

PIPE DIAMETER "D" IN INCHES	MIN. RADIUS FOR PE PIPE IN FEET	MIN. RADIUS "R" FOR SDR-11	MIN. RADIUS "R" FOR SDR-9
2	4	5.5	
3	6	8.3	
4	8	11.0	
6	12	16.5	
8	16	22.0	
10	20	27.5	
12	24	33.0	
16	32	44.0	
18	36	49.5	
20	40	55.0	

MANATEE COUNTY  
 PUBLIC WORKS DEPARTMENT

REV. BY	DATE

NOVEMBER 1, 1999  
 DATE OF APPROVAL

DIRECTIONAL BORE  
 CANAL CROSSING

URW-32



MANATEE COUNTY  
PUBLIC WORKS  
DEPARTMENT  
ENGINEERING DIVISION

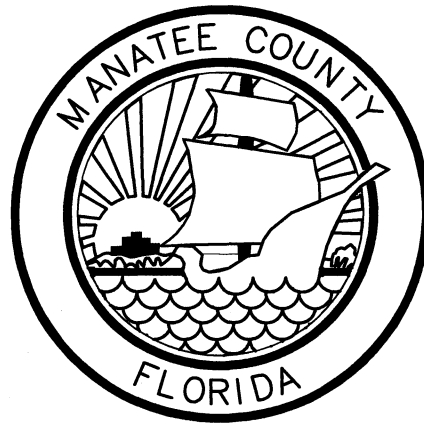

MARCH 1997  
REVISED NOVEMBER, 1999

STANDARDS FOR  
SANITARY SEWER  
SYSTEM

SUBSTANTIAL EFFORT HAS BEEN MADE TO ENSURE THE INFORMATION IN THESE STANDARDS IS ACCURATE HOWEVER, MANATEE COUNTY PUBLIC WORKS DEPT. CANNOT ACCEPT RESPONSIBILITY FOR ANY ERRORS OR OVERSIGHT IN THE USE OF THE MATERIAL OR IN THE PREPARATION OF THE ENGINEERING PLANS. THIS PUBLICATION IS INTENDED FOR USE BY PROFESSIONAL PERSONNEL COMPETENT TO EVALUATE THE SIGNIFICANCE AND LIMITATIONS OF THE CONTENTS AND ABLE TO ACCEPT RESPONSIBILITY FOR THE APPLICATION OF THE MATERIAL IT CONTAINS.

THE DESIGNER MUST RECOGNIZE THAT NO HANDBOOK OR CODE CAN BE A SUBSTITUTE FOR EXPERIENCED ENGINEERING JUDGEMENT.

USERS OF THESE STANDARDS ARE ENCOURAGED TO OFFER COMMENTS TO MANATEE COUNTY PUBLIC WORKS DEPARTMENT ON THE CONTENTS OF THIS PUBLICATION AND SUGGESTIONS FOR CHANGES IN THE FUTURE EDITIONS.

PRODUCTS TO BE CONSIDERED "APPROVED EQUAL" SHALL BE SUBMITTED TO THE PUBLIC WORKS DIRECTOR FOR APPROVAL.

THESE RECOMMENDATIONS ARE UNDER CONSTANT REVIEW AND ARE SUBJECT TO CHANGES BY THE DIRECTOR OF PUBLIC WORKS.

MANATEE COUNTY PUBLIC WORKS DEPARTMENT		INTRODUCTION MANATEE COUNTY UTILITY STANDARDS	US-1
REV. BY RTH	DATE 11/99		
MARCH 18, 1997 DATE OF APPROVAL			

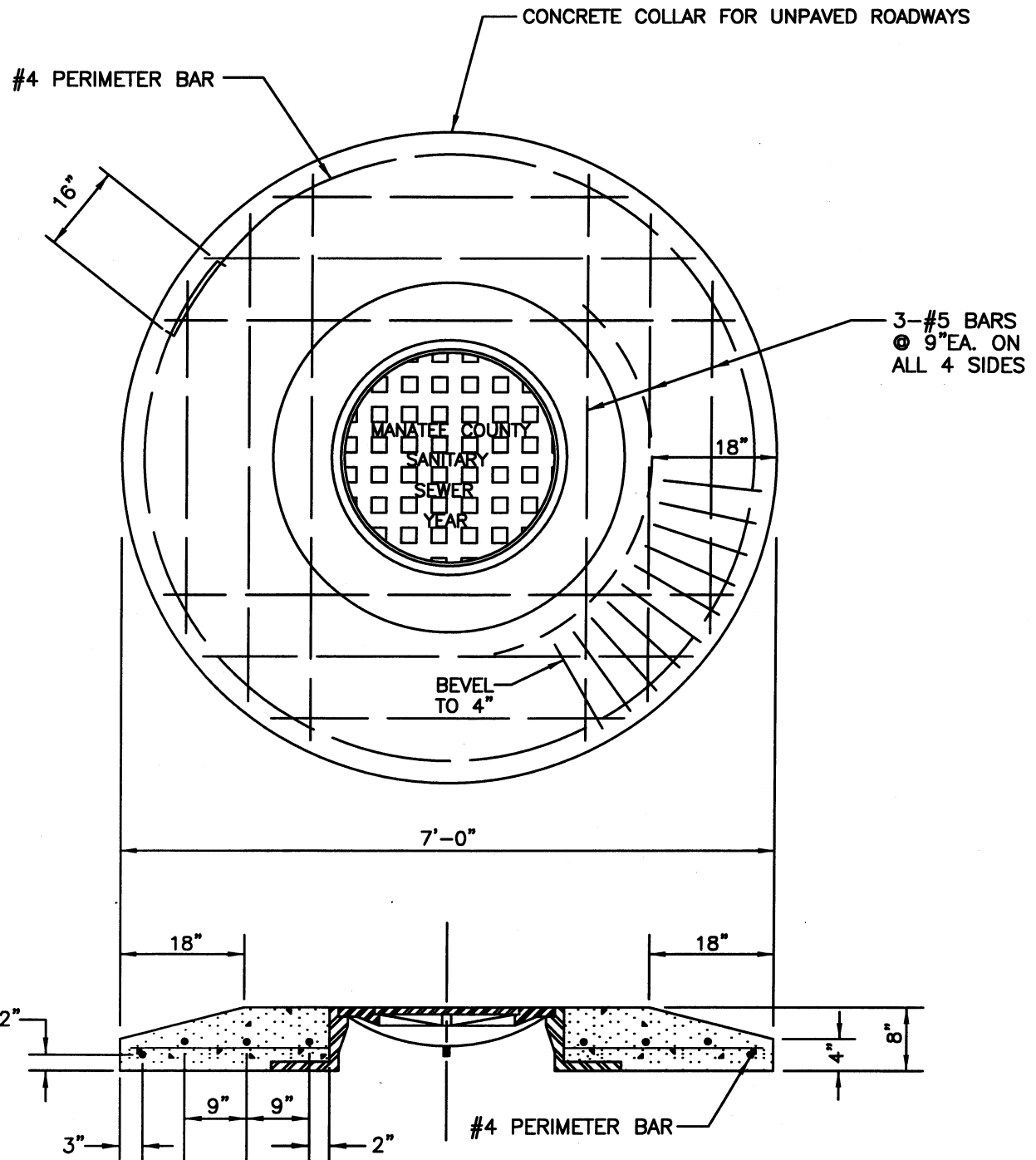

**NOTE:**

OMIT "MANATEE COUNTY" IF PRIVATELY MAINTAINED.

MANATEE COUNTY  
PUBLIC WORKS DEPARTMENT

MANHOLE COVER &  
CONCRETE COLLAR  
FOR UNPAVED  
ROADWAYS

US-10

REV. BY	DATE

MARCH 18, 1997  
DATE OF APPROVAL

**NOTES:**

- 1.) USE OF TYPE A-2 AND A-3 PIPE BEDDING TO BE DETERMINED IN THE FIELD BY THE ENGINEER.
- 2.) 10" MAX. FOR PIPE DIAMETER LESS THAN 24"; 12" MAX. FOR PIPE DIAMETER 24" AND LESS THAN 42"; 24" MAX. FOR PIPE DIAMETER 42" AND OVER.
- 3.) 4" MAX. FOR PIPE 16" DIAMETER & LESS; 6" MAX. FOR PIPE 18" TO 36" DIAMETER; AND 9" MAX FOR PIPE 42" DIAMETER AND LARGER.
- 4.) INSTALLATION SHALL BE IN ACCORDANCE WITH THE MANUFACTURER'S SPECIFICATIONS.

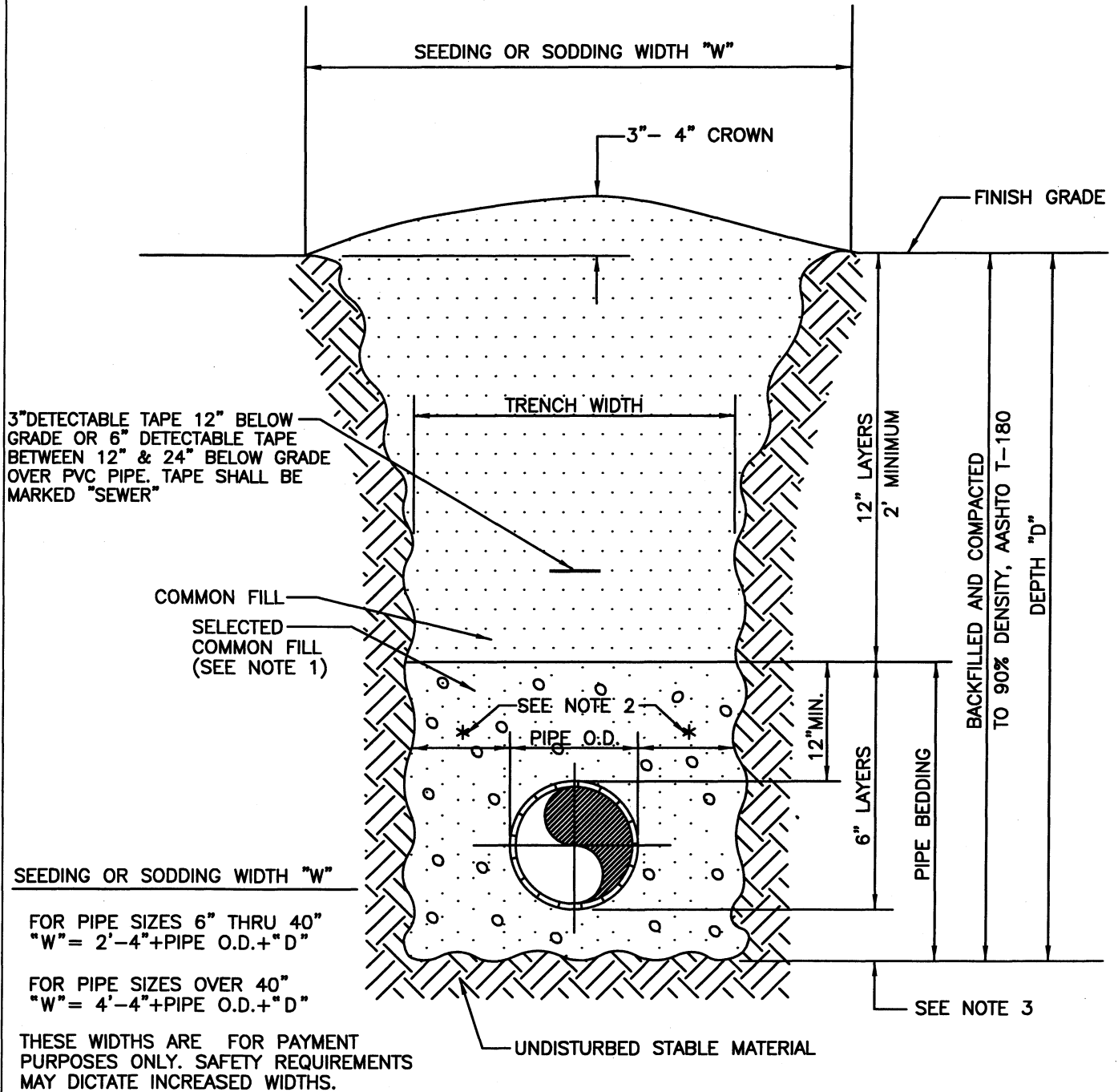

MANATEE COUNTY  
PUBLIC WORKS DEPARTMENT

TRENCH DETAIL  
UNIMPROVED SURFACE  
TYPE A-1 PIPE BEDDING

US-11

REV. BY	DATE
RTH	11/99

MARCH 18, 1997  
DATE OF APPROVAL



**NOTES:**

- 1.) USE OF TYPE A-2 AND A-3 PIPE BEDDING TO BE DETERMINED IN THE FIELD BY THE ENGINEER.
- 2.) 10" MAX. FOR PIPE DIAMETERS LESS THAN 24"; 12" MAX. FOR PIPE DIAMETER 24" AND LESS THAN 42"; 24" MAX. FOR PIPE DIAMETER 42" AND OVER.
- 3.) 4" MAX. FOR PIPE 16" DIAMETER & LESS; 6" MAX. FOR PIPE 18" TO 36" DIAMETER; AND 9" MAX. FOR PIPE 42" DIAMETER AND LARGER.
- 4.) INSTALLATION SHALL BE IN ACCORDANCE WITH THE MANUFACTURER'S SPECIFICATIONS.
- 5.) WEARING SURFACE TO BE SAME TYPE & THICKNESS (1 1/2" MIN.) AS EXISTING PAVEMENT.
- 6.) SHEETING ORDERED LEFT IN PLACE TO BE CUT OFF 24" BELOW FINISH GRADE OR 12" BELOW SUBGRADE
- 7.) BASE SHALL BE 6" MINIMUM THICKNESS SAND ASPHALT, 10" MIN. THICKNESS CRUSHED CONCRETE, OR APPROVED EQUAL.
- 8.) BACKFILL AASHTO M-145 SHALL BE PLACED IN LAYERS NOT TO EXCEED 6 INCHES. EACH LAYER SHALL BE THOROUGHLY TAMPED AND/OR ROLLED TO 98% AASHTO T-180 DENSITY.
- 9.) TEMPORARY PATCHES WILL BE INSTALLED TO PROVIDE A SMOOTH ALL WEATHER SURFACE AT ALL TIMES. PERMANENT REPLACEMENT TO BE MADE AS SOON AS POSSIBLE.
- 10.) NOTES 5.) THRU 9.) ARE MINIMUM REQUIREMENTS. REFER TO MANATEE COUNTY TRANSPORTATION DEPARTMENT STANDARDS FOR ADDITIONAL REQUIREMENTS.

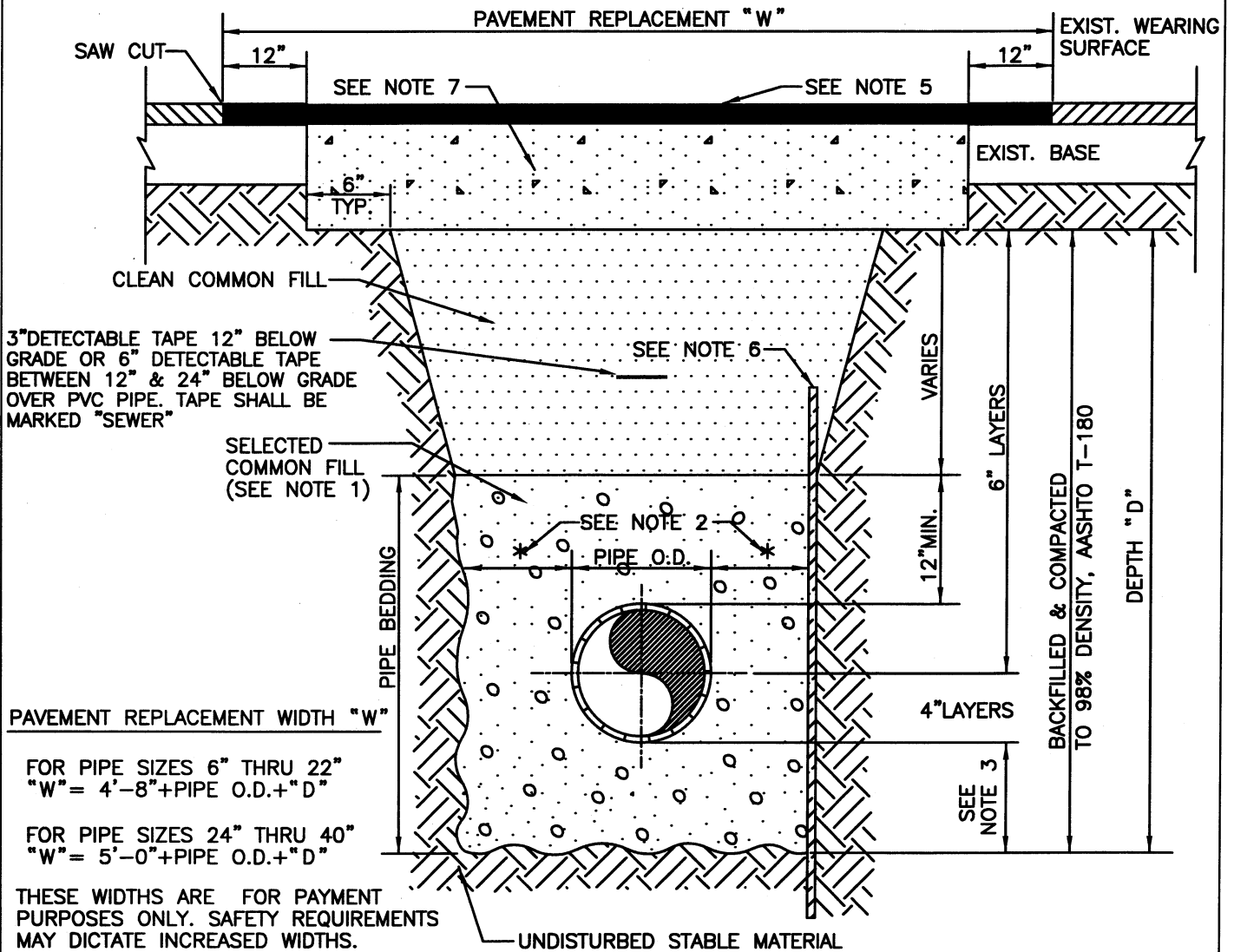

MANATEE COUNTY PUBLIC WORKS DEPARTMENT		TRENCH DETAIL		US-12
REV. BY	DATE	ASPH. PAVEMENT SURFACE		
RTH	11/99	TYPE A-1 PIPE BEDDING		
MARCH 18, 1997				
DATE OF APPROVAL				

**NOTES:**

- 1.) USE OF TYPE A-2 AND A-3 PIPE BEDDING TO BE DETERMINED IN THE FIELD BY THE ENGINEER.
- 2.) 10" MAX. FOR PIPE DIAMETER LESS THAN 24"; 12" MAX. FOR PIPE DIAMETER 24" AND LESS THAN 42"; 24" MAX. FOR PIPE DIAMETER 42" AND OVER.
- 3.) 4" MAX. FOR PIPE 16" DIAMETER & LESS; 6" MAX. FOR PIPE 18" TO 36" DIAMETER AND 9" MAX. FOR PIPE 42" DIAMETER AND LARGER.
- 4.) INSTALLATION SHALL BE IN ACCORDANCE WITH THE MANUFACTURER'S SPECIFICATIONS.
- 5.) THICKNESS TO MATCH EXISTING OR BE 8" MINIMUM, WHICHEVER IS GREATER.

FOR NOTES 6.) THRU 10.) SEE DETAIL US-12

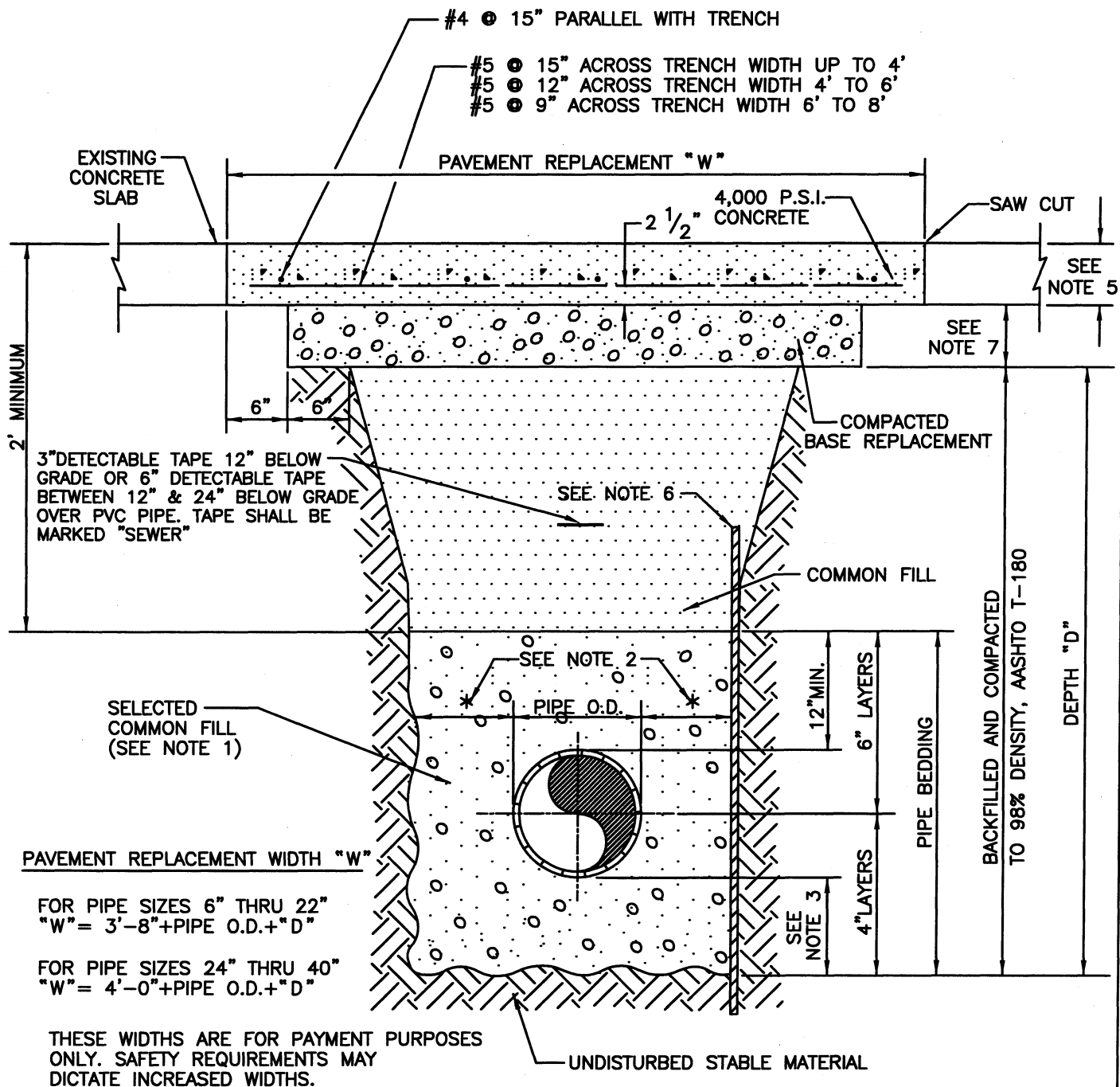

PAVEMENT REPLACEMENT WIDTH "W"

FOR PIPE SIZES 6" THRU 22"  
 "W" = 3'-8" + PIPE O.D. + "D"

FOR PIPE SIZES 24" THRU 40"  
 "W" = 4'-0" + PIPE O.D. + "D"

THESE WIDTHS ARE FOR PAYMENT PURPOSES ONLY. SAFETY REQUIREMENTS MAY DICTATE INCREASED WIDTHS.

MANATEE COUNTY  
 PUBLIC WORKS DEPARTMENT

TRENCH DETAIL

CONC. PAVEMENT SURFACE  
 TYPE A-1 PIPE BEDDING

US-13

REV. BY	DATE
RTH	11/99

MARCH 18, 1997  
 DATE OF APPROVAL

**NOTES:**

- 1.) 10" MAX. FOR PIPE DIAMETER LESS THAN 24"; 12" MAX. FOR PIPE DIAMETER 24" AND LESS THAN 42"; 24" MAX. FOR PIPE DIAMETER 42" AND OVER.
- 2.) 4" MAX. FOR PIPE 16" DIAMETER AND LESS; 6" MAX. FOR PIPE DIAMETER 18" TO 36" AND 9" MAX. FOR PIPE DIAMETER 42" AND OVER.
- 3.) INSTALLATION SHALL BE IN ACCORDANCE WITH THE MANUFACTURER'S SPECIFICATIONS.

3" DETECTABLE TAPE 12" BELOW GRADE OR 6" DETECTABLE TAPE BETWEEN 12" & 24" BELOW GRADE OVER PVC PIPE. TAPE SHALL BE MARKED "SEWER"

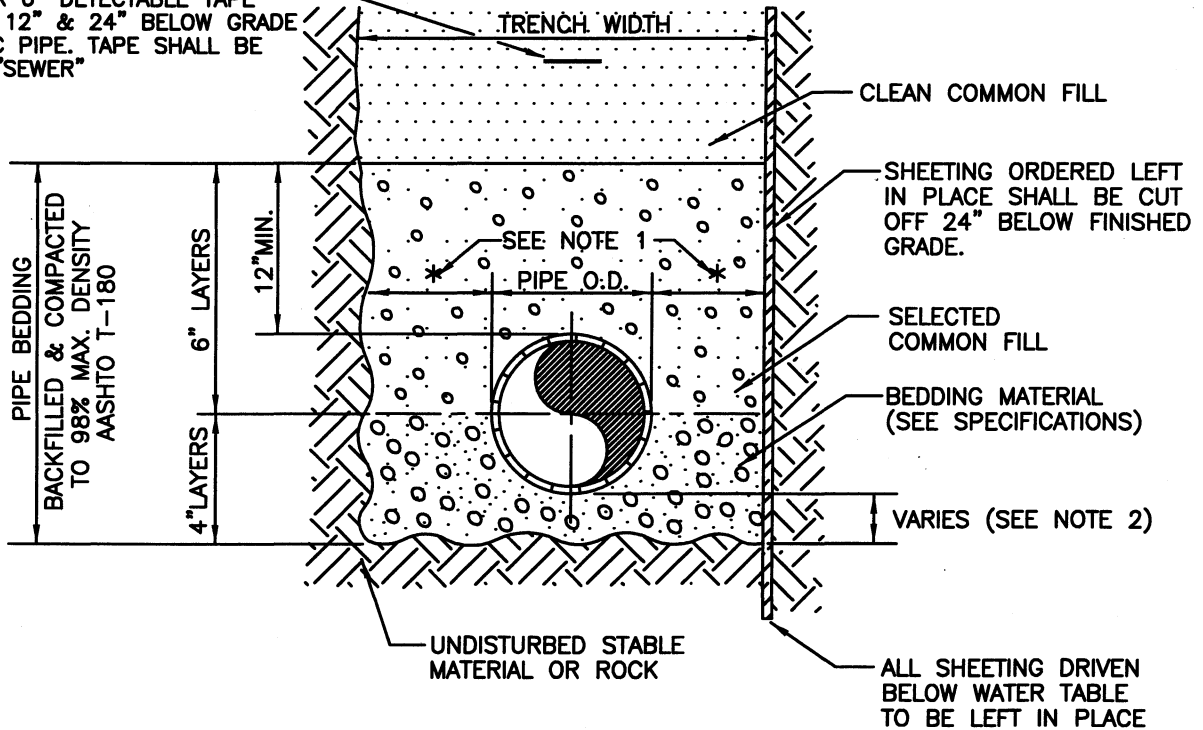

<b>MANATEE COUNTY</b> PUBLIC WORKS DEPARTMENT		<b>TRENCH DETAIL</b> <b>TYPE A-2 PIPE BEDDING</b>	<b>US-14</b>
REV. BY RTH	DATE 11/99		
<b>MARCH 18, 1997</b> DATE OF APPROVAL			

NOTES:

- 1.) 10" MAX. FOR PIPE DIAMETER LESS THAN 24"; 12" MAX. FOR PIPE DIAMETER 24" AND LESS THAN 42"; 24" MAX. FOR PIPE DIAMETER 42" AND OVER.
- 2.) 4" MAX. FOR PIPE 16" DIAMETER & LESS; 6" MAX. FOR PIPE 18" TO 36" DIAMETER; AND 9" MAX FOR PIPE 42" DIAMETER AND LARGER.
- 3.) INSTALLATION SHALL BE IN ACCORDANCE WITH THE MANUFACTURER'S SPECIFICATIONS.

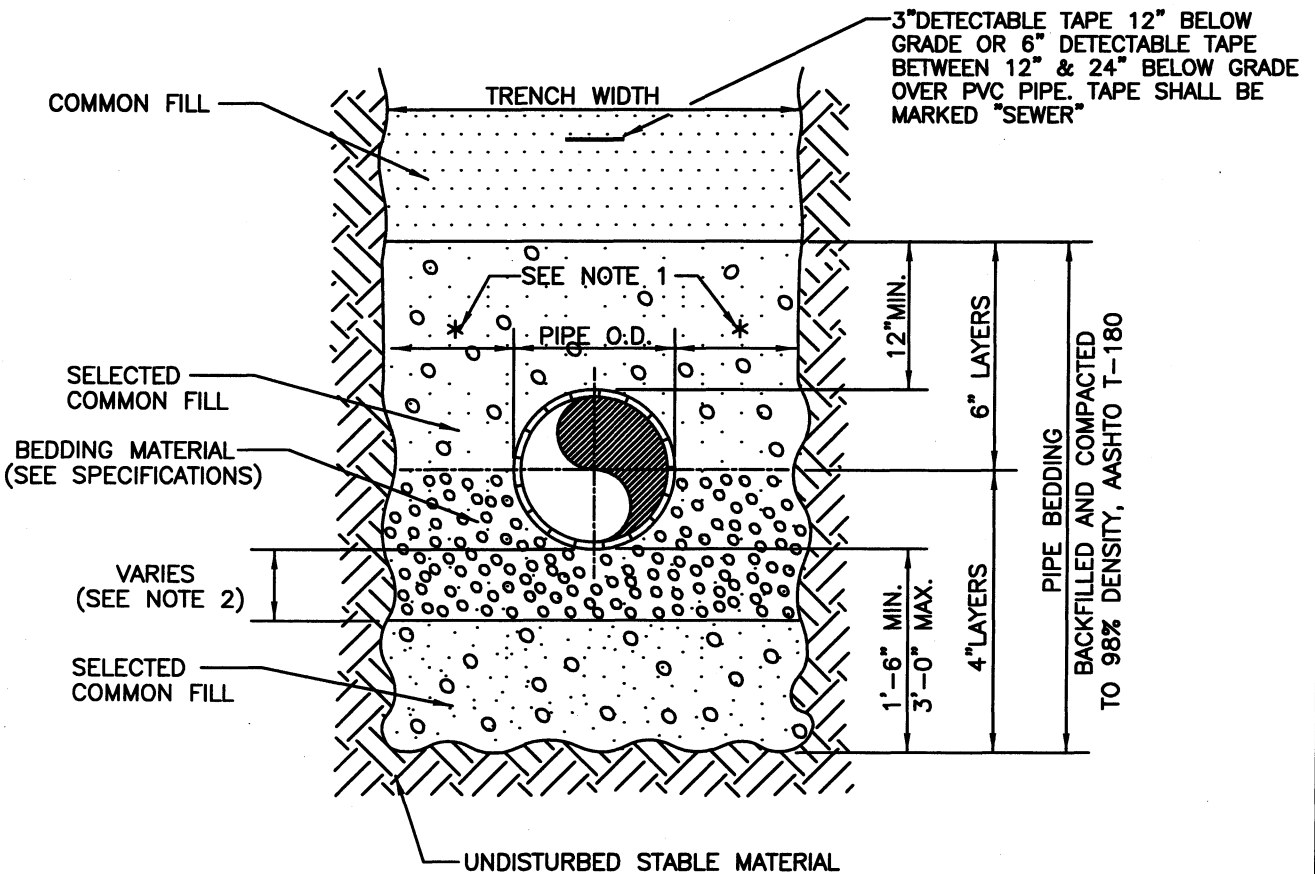

MANATEE COUNTY  
PUBLIC WORKS DEPARTMENT

TRENCH DETAIL

US-15

REV. BY	DATE
RTH	11/99

MARCH 18, 1997  
DATE OF APPROVAL

TYPE A-3 PIPE BEDDING

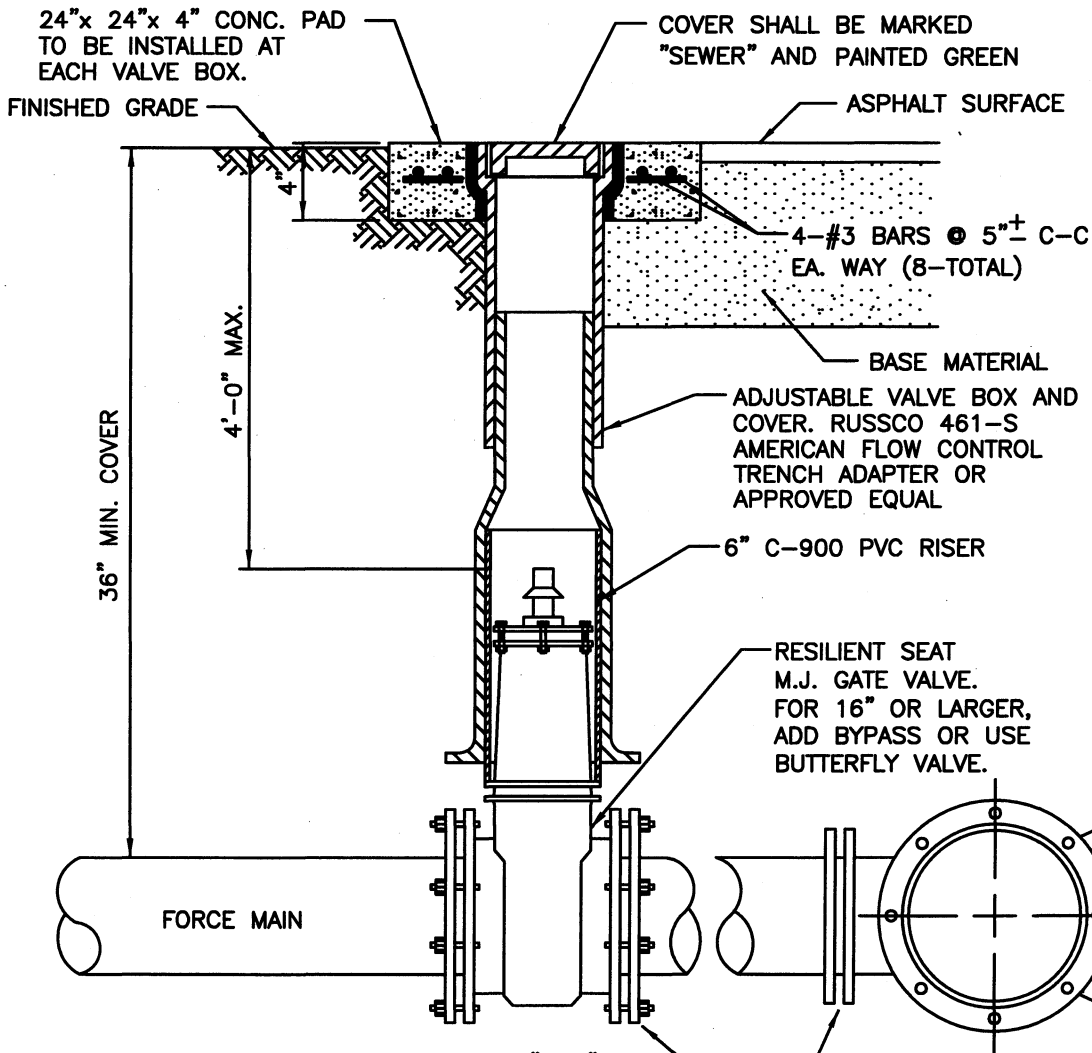
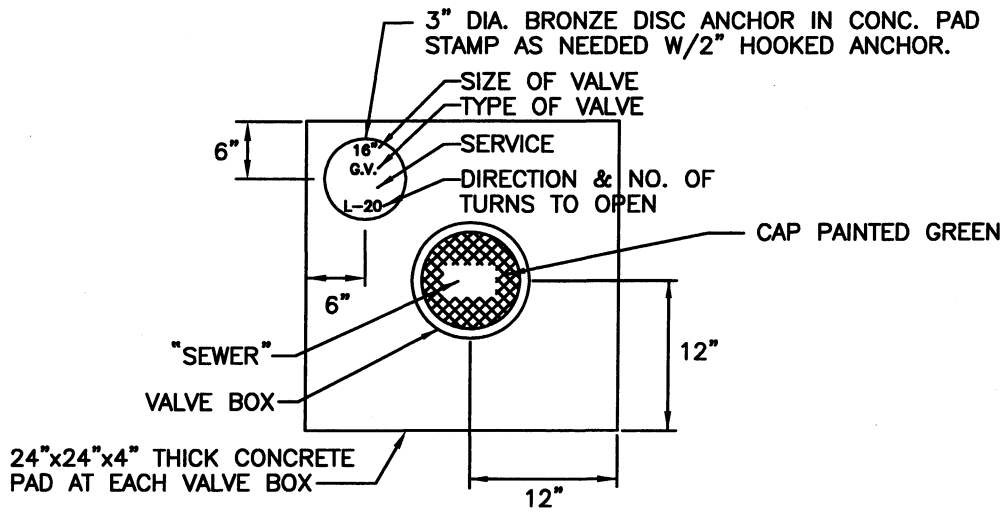

**NOTES:**

1. GATE VALVE TO BE MARKED IN CURB WITH A "SV" WITH A FOOTAGE FROM THE BACK OF CURB TO THE VALVE OR IF NO CURB, A GREEN DISC WITH "SV" IN THE EDGE OF PAVEMENT WITH THE FOOTAGE FROM THE DISC TO THE VALVE.
2. ALL EXISTING AND PROPOSED VALVE BOXES SHALL BE ADJUSTED TO FINISHED GRADES AS ESTABLISHED IN THE FIELD.
3. SEWER VALVES SHALL NOT BE PLACED IN HANDICAPPED RAMPS.
4. ALL EXPOSED EDGES OF CONCRETE SHALL BE CHAMFERED 1/2".

<b>MANATEE COUNTY</b> PUBLIC WORKS DEPARTMENT		<b>GATE VALVE, BOX, COVER AND TAG</b>	US-16
REV. BY	DATE		
RTH	11/99		

**NOTES:**

1. RUBBER DONUTS ARE NOT TO BE USED.
2. SANITARY SEWER SERVICES TO BE MARKED IN CURB WITH A GREEN DISC THAT HAS THE FOOTAGE FROM CURB TO CLEAN-OUT.
3. SANITARY SEWER CLEAN-OUTS SHALL NOT BE LOCATED IN DRAINAGE SWALES, EASEMENTS, SIDEWALKS OR DRIVEWAYS.
4. NO SERVICE CONNECTIONS TO BE MADE TO THE CLEAN-OUT RISER. ALL DOMESTIC CONNECTIONS SHALL BE MADE TO THE STUB-OUT PROVIDED.

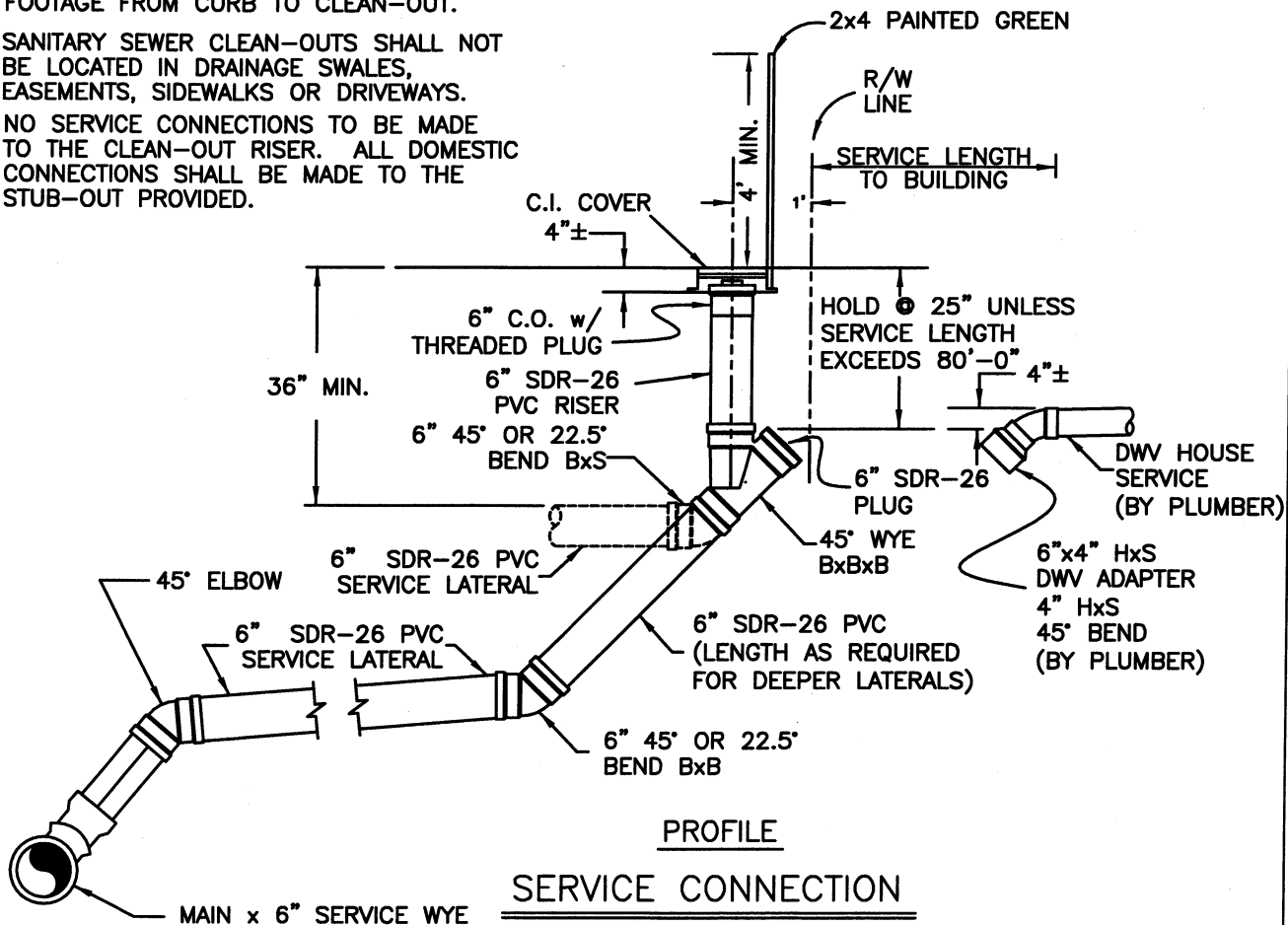

PROFILE  
SERVICE CONNECTION

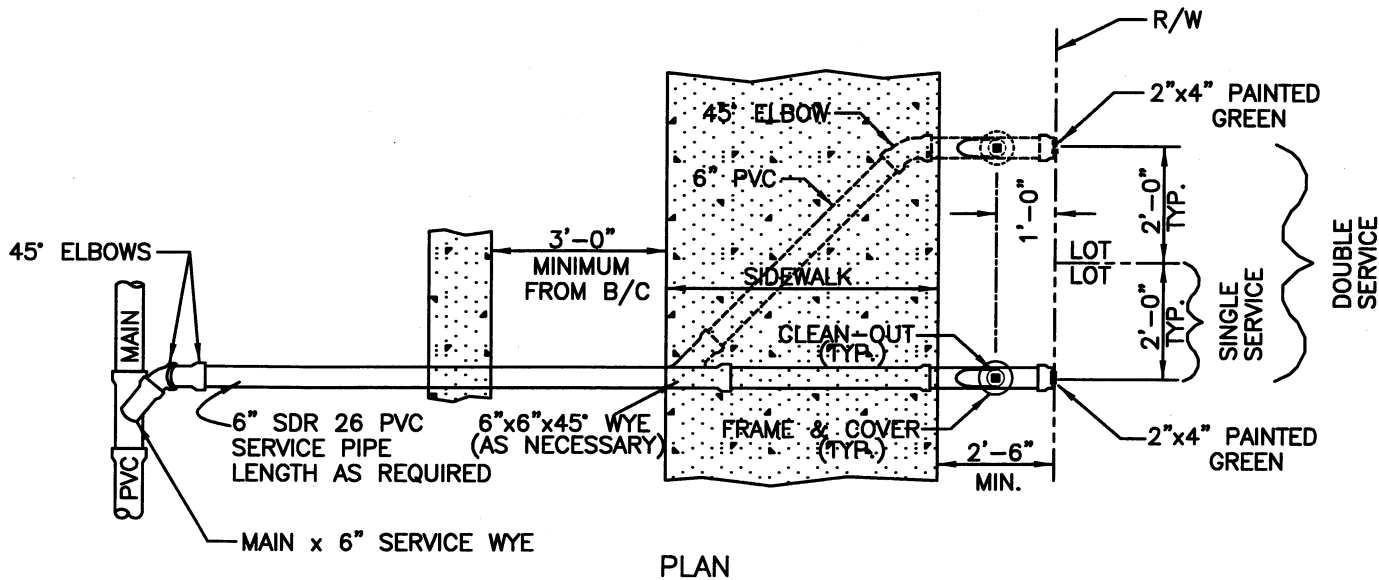

PLAN  
SINGLE & DOUBLE SERVICE

MANATEE COUNTY PUBLIC WORKS DEPARTMENT		MARCH 18, 1997 DATE OF APPROVAL	SINGLE AND DOUBLE SERVICE CONNECTION DETAILS	US-17
REV. BY	DATE			
RTH	11/99			

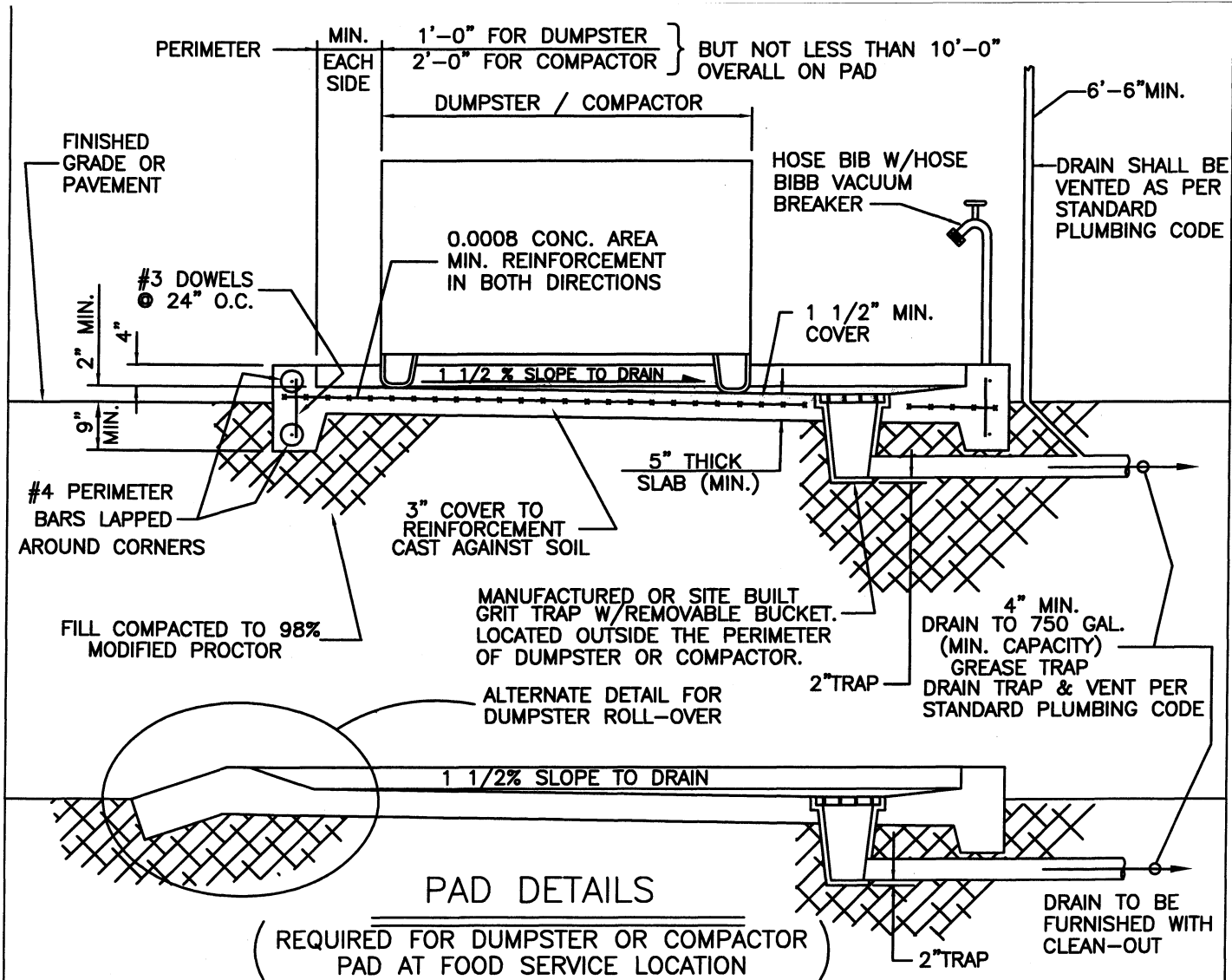

NOTE : MINIMUM GATE OPENING THRU FENCE OR SCREEN IS 9'-5"

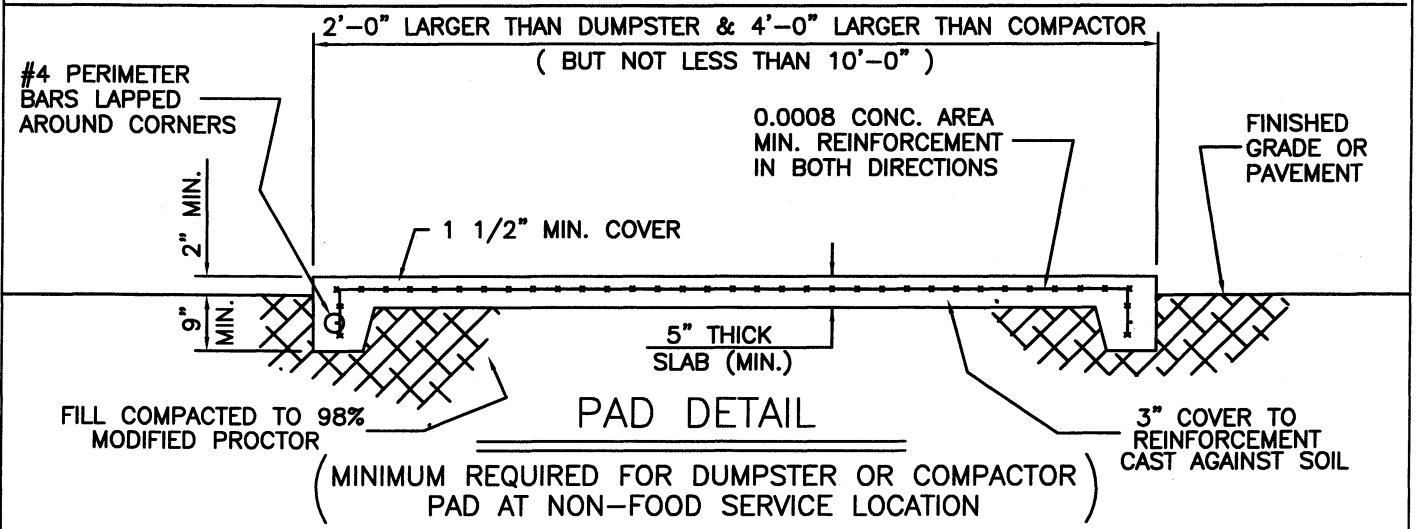

MIN. CONC. STRENGTH  $f'_c = 3000$  P.S.I.      MIN. REINFORCEMENT STRENGTH  $f_y = 60,000$  P.S.I.

MANATEE COUNTY PUBLIC WORKS DEPARTMENT		COMPACTOR AND DUMPSTER PAD TYPICAL DETAILS	US-18
REV. BY	DATE		
	MARCH 18, 1997		
	DATE OF APPROVAL		

NOTES:

1. PIPE FITTINGS TO BE AWWA C-907, CLASS 150, (DR 18) MINIMUM.
2. PVC RESTRAINERS TO BE EBBA IRON SERIES 1100 PV, 1100 HV, 1500, 1600 & 3500 (AT M.H.) UNI-FLANGE EQUIVALENT IS ACCEPTABLE, SUBMIT DETAILS TO ENGINEERING DIVISION, M.C.P.W.D., FOR APPROVAL.
3. WHEN FORCE MAIN ENTERS M.H. ABOVE BOTTOM, REFER TO US-7, FORCE MAIN INSIDE DROP CONNECTION.
4. BUILD CHANNEL FOR F/M FLOW TO BLEND IN WITH EXISTING CHANNEL.

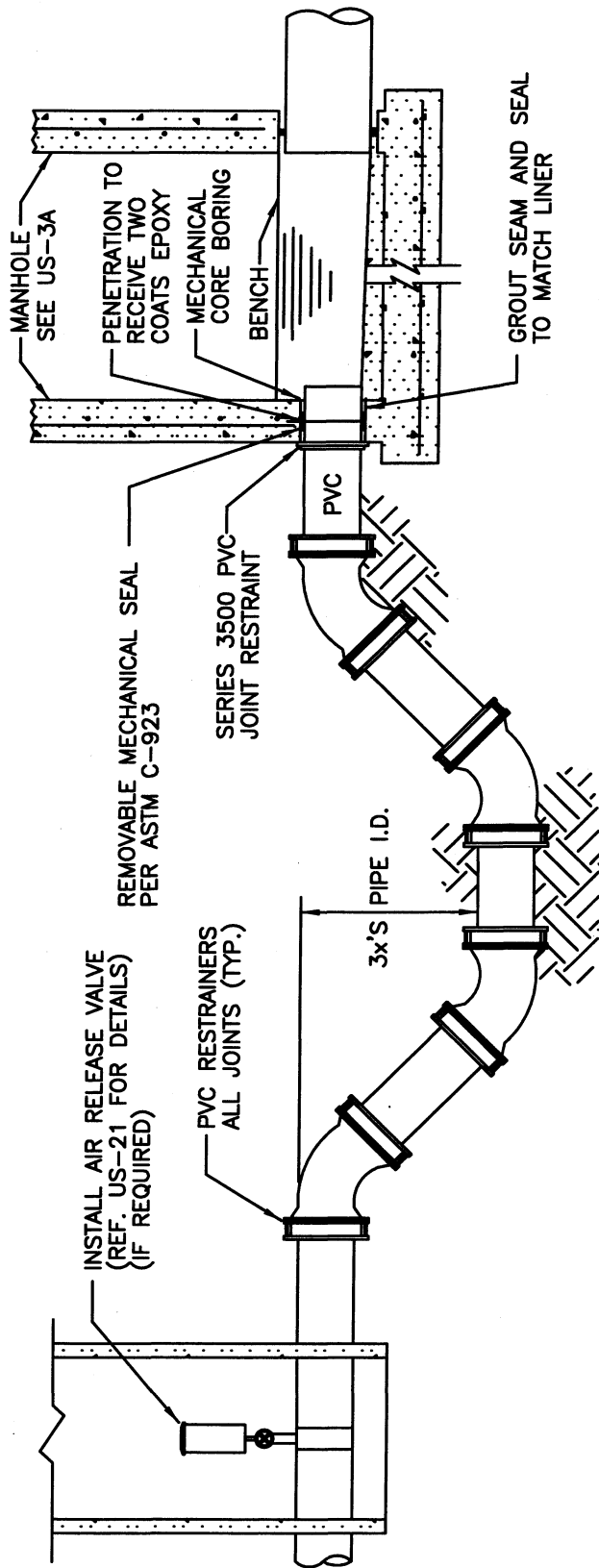

MANATEE COUNTY  
PUBLIC WORKS DEPARTMENT

REV. BY	DATE

MARCH 18, 1997  
DATE OF APPROVAL

FORCE MAIN  
CONNECTION TO  
MANHOLE DETAIL

US-19



## TABLE OF CONTENTS

### UTILITY STANDARDS--SANITARY SEWER

US-0	COVER
US-1	INTRODUCTION - MANATEE COUNTY STANDARDS
US-2	TABLE OF CONTENTS - SANITARY SEWER
US-3	STANDARD PRE-CAST SANITARY SEWER MANHOLE FOR UNDISTURBED FLOW
US-3A	STANDARD PRE-CAST SANITARY SEWER MANHOLE FOR TURBULENT FLOW
US-3B	ALTERNATE DETAIL SANITARY SEWER MANHOLE FOR TURBULENT FLOW
US-3C	STANDARD FIBERGLASS SANITARY SEWER MANHOLE
US-4	STANDARD PRE-CAST SANITARY SEWER ECCENTRIC MANHOLE
US-5	STANDARD PRE-CAST SHALLOW MANHOLE
US-6	GRAVITY INSIDE-DROP FOR RETROFIT OF EXISTING MANHOLE
US-7	FORCE MAIN RETROFIT FOR INSIDE-DROP CONNECTION
US-8	GRAVITY SEWER INTO EXISTING PUMP STATION
US-9	GRAVITY SEWER STANDARD DROP CONNECTION DETAIL
US-10	MANHOLE COVER & CONCRETE COLLAR FOR UNPAVED ROADWAYS
US-11	TRENCH DETAIL--UNIMPROVED SURFACE, TYPE A-1 PIPE BEDDING
US-12	TRENCH DETAIL--ASPHALT PAVEMENT SURFACE, TYPE A-1 PIPE BEDDING
US-13	TRENCH DETAIL--CONCRETE PAVEMENT SURFACE, TYPE A-1 PIPE BEDDING
US-14	TRENCH DETAIL--TYPE A-2 PIPE BEDDING
US-15	TRENCH DETAIL--TYPE A-3 PIPE BEDDING
US-16	GATE VALVE, BOX, COVER AND TAG
US-17	SINGLE AND DOUBLE SERVICE CONNECTION DETAILS
US-18	COMPACTOR AND DUMPSTER PAD TYPICAL DETAILS
US-19	FORCE MAIN CONNECTION TO MANHOLE DETAIL
US-20A	SEWAGE PUMP STATION--WET WELL & VALVE VAULT PLAN VIEW DETAILS
US-20B	SEWAGE PUMP STATION--WET WELL & VALVE VAULT SECTIONAL VIEW DETAILS
US-20C	SEWAGE PUMP STATION--METER & ELECTRICAL DETAILS
US-20D	SEWAGE PUMP STATION CONTROL PANEL DETAILS (230V)
US-20E	SEWAGE PUMP STATION CONTROL PANEL DETAILS (460V)
US-21	BELOW GRADE AIR RELEASE VALVE
US-22	FIBERGLASS DOGHOUSE MANHOLE
US-23	MINIMUM ACCESS/EGRESS REQUIREMENTS FOR LIFT STATIONS ADJACENT TO BUSY THOROUGHFARES
US-24	5/8" WATER METER & BACKFLOW PREVENTER ABOVE GROUND DETAIL FOR LIFT STATIONS
US-25	DIRECTIONAL BORE ROADWAY CROSSING
US-26	DIRECTIONAL BORE CANAL CROSSING

**NOTE:**

SEWAGE WORKS SHALL BE DESIGNED IN ACCORDANCE WITH F.D.E.P. REGULATIONS AND "RECOMMENDED STANDARDS FOR SEWAGE WORKS" BY THE GREAT LAKES--UPPER MISSISSIPPI RIVER BOARD OF STATE PUBLIC HEALTH AND ENVIRONMENTAL MANAGERS LATEST EDITION.

MANATEE COUNTY PUBLIC WORKS DEPARTMENT		TABLE OF CONTENTS  SANITARY SEWER	US-2
REV. BY	DATE		
RTH	11/99		
MARCH 18, 1997 <hr style="width: 50%; margin: auto;"/> DATE OF APPROVAL			

EXACT LAYOUT MAY VARY

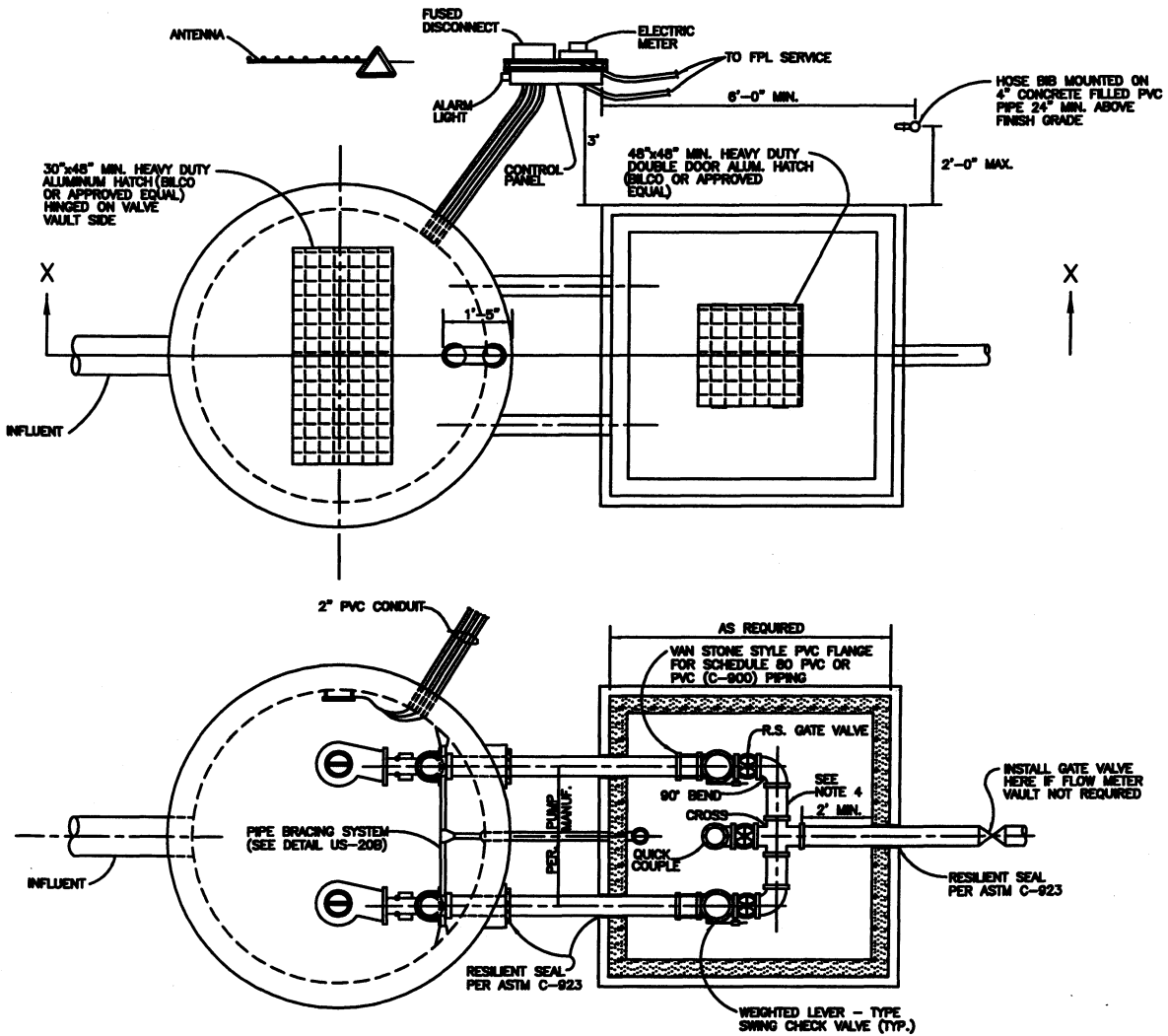

PLAN VIEW

FOR SECTION X-X  
SEE SHEET US-20B

GENERAL NOTES:

1. ALL ACCESS COVERS SHALL BE ALUMINUM, WITH STAINLESS STEEL HARDWARE AND RATED FOR 300 P.S.F. LOADING. ALL ALUMINUM SURFACES IN CONTACT WITH CONCRETE SHALL HAVE 2 COATS BITUMASTIC EPOXY, TOTAL 16 MILS THK. ALL ACCESS COVERS SHALL BE EQUIPPED WITH A LOCKING STAPLE OR BAR FOR USE WITH A PAULOCK. PAULOCKS SHALL BE FURNISHED BY THE PUBLIC WORKS DEPARTMENT.
2. INSTALL WET WELL VENT ON THE VALVE VAULT SIDE OF THE WET WELL HATCH COVER.
3. GROUND SHALL BE SLOPED AWAY FROM SLAB TO NATURAL GROUND ELEVATION IN ALL DIRECTIONS. RESTORATION SHALL INCLUDE SOODING TO 20' FEET BEYOND CONCRETE STRUCTURES.
4. ALL IRON BODY FITTINGS SHALL BE COATED WITH A FUSION BONDED FACTORY EPOXY COATING. (INSIDE AND OUTSIDE)
5. ALL PIPING FROM THE PUMP BASE ELLS TO THE PUMP CHECK VALVE SHALL BE CLASS 200, DR-14, ANMA C-800 OR SCH. 80 PVC. ALL PIPING DOWN STREAM FROM THE PUMP PIPING CROSS IN THE VALVE VAULT SHALL BE DR-14, C-800. ALL PVC PIPING INSIDE THE WET WELL AND VALVE VAULT SHALL BE CONNECTED TO FLANGED FITTINGS USING SCH. 80 PVC VAN STONE STYLE FLANGE ADAPTERS. ALL SCH. 80 PVC PIPING CONNECTIONS TO SCH. 80 PVC FITTINGS SHALL BE SOLVENT WELD JOINTS. ALL FLOW METER VAULT FLANGE CONNECTIONS SHALL USE IRON BODY FLANGE ADAPTERS. ALL BURIED FITTINGS SHALL BE RESTRAINED JOINT.
6. ALL SCH. 80 PVC PIPE SHALL BE GRAY. ALL OTHER PIPING SHALL BE COLOR CODED IN ACCORDANCE WITH THE PUBLIC WORKS STANDARDS. GREEN—RAW SEWAGE; PURPLE—EFFLUENT; BLUE—POTABLE WATER.
7. ANCHORS & LIFTING DEVICES SHALL NOT PENETRATE THE WALLS OF THE WET WELL.
8. ALL INTERIOR SURFACES OF WET WELL SHALL BE LINED. (SEE DETAIL US-3A) INSIDE VALVE VAULT SHALL BE COATED WITH TWO COATS EPOXY.
9. ALL METAL APPURTENANCES INCLUDING BOLTS, NUTS AND WASHERS INSIDE THE WET WELL AND VALVE VAULT SHALL BE STAINLESS STEEL UNLESS OTHERWISE NOTED (TYPE 304). ALL STAINLESS STEEL BOLTS SHALL BE TREATED WITH NEVER SEIZE PRIOR TO ASSEMBLY.
10. VERTICAL PVC PUMP DISCHARGE PIPE IN THE WET WELL SHALL BE BRACED EVERY EIGHT (8) LINEAR FEET TO PREVENT EXCESSIVE BOWING. THE PIPE SHALL BE CLAMPED TO A SINGLE LENGTH OF 1-5/8" STAINLESS STEEL CHANNEL INSTALLED HORIZONTALLY AND ANCHORED TO THE WET WELL WALL AT EACH END WITH A CENTER BRACE OF 1-5/8" CHANNEL ATTACHED TO THE BACK OF THE WET WELL. THE PIPE CLAMPS SHALL BE A MINIMUM OF 1-1/2" WIDE, 12 GA. STAINLESS STEEL.
11. VALVE & METER VAULTS SHALL BE PRECAST TYPE II REINFORCED CONCRETE.
12. CONTRACTOR SHALL TAKE ALL NECESSARY PRECAUTIONS TO PREVENT FLOTATION DURING CONSTRUCTION. ENGINEER SHALL SUBMIT FLOTATION CALCULATIONS TO MCPWD, ENGINEERING DIVISION AT PLAN REVIEW SUBMITTAL.
13. BASE AND FIRST WALL SECTION SHALL BE MONOLITHIC.
14. PVC RESTRAINTS SHALL BE MANUFACTURED BY STAR PIPE PRODUCTS INC., UNI-FLANGE DIVISION OF HAFPCO, INC. OR APPROVED EQUAL.
15. THE PUMP STATION SHALL BE CONSTRUCTED IN ACCORDANCE WITH PUBLIC WORKS DEPARTMENT STANDARDS & SPECIFICATIONS.
16. PROVIDE POTABLE WATER SERVICE CONNECTION, 3/4" BRASS LOCKSHIELD AND LOOSE KEY HOSE BIB. PROVIDE WETS 600 BACKFLOW PREVENTER (OR APPROVED EQUAL). ALL WATER SERVICE PIPING FROM WATER METER TO BE TYPE "L" COPPER OR BRASS, 3/4" MIN. DIAMETER.
17. HOSE BIB TO BE A MAXIMUM OF 2 FEET FROM THE VALVE VAULT, A MINIMUM OF 6 FEET FROM THE ELECTRICAL CONTROL PANEL, 24" ABOVE THE SURROUNDING FINISH GRADE, AND ANCHORED TO A 4" PVC CONCRETE FILLED PIPE.
18. ELECTRICAL SERVICE SHALL BE 240 VOLT, 3 PHASE MINIMUM UNLESS UNAVAILABLE FROM THE ELECTRICAL UTILITY.
19. WATER METER ASSEMBLY TO BE INSTALLED BY CONTRACTOR AS PART OF WATER SERVICE CONNECTION WITH FEES PAID BY OWNER.
20. EVERY EFFORT SHALL BE MADE BY THE CONTRACTOR TO CONSTRUCT WATERTIGHT STRUCTURES. COMPLETED STRUCTURES THAT ARE NOT WATERTIGHT AND/OR DO NOT MEET THE REQUIREMENTS OF ASTM C-443 WILL BE REJECTED.
21. FLEXIBLE GASKET CONNECTORS SHALL MEET THE REQUIREMENTS OF ASTM C-823 LATEST REVISION & ARE REQUIRED IN ALL MANHOLES.
22. ALL GATE VALVES SHALL BE RESILIENT SEAT.
23. THE METER AND BACKFLOW PREVENTER SHALL BE INSTALLED AT THE EASEMENT OR PROPERTY LINE IN ACCORDANCE WITH MANATEE COUNTY REQUIREMENTS (SEE DETAIL US-25). SEE PLUMBING CODE FOR BACKFLOW DETAILS.
24. FLOW METER IS REQUIRED WHEN A VARIABLE SPEED PUMPING SYSTEM IS USED.
25. ELECTRICAL CONDUIT SHALL BE RUN BY THE SHORTEST ROUTE POSSIBLE FROM THE ELECTRICAL SOURCE TO THE CONTROL PANEL AND FROM THE CONTROL TO THE LIFT STATION WET WELL. NO ELECTRICAL SHALL BE INSTALLED BETWEEN THE WET WELL AND VALVE VAULT STRUCTURES.
26. THE VALVE VAULT SHALL HAVE A MINIMUM CLEARANCE OF 12" FROM FLANGES TO THE VALVE VAULT WALL, 18" FROM FLANGES TO THE VALVE VAULT FLOOR AND 24" FROM THE CROSS TO THE VALVE VAULT WALL AT THE FORCE MAIN EXIT POINT.

MANATEE COUNTY  
PUBLIC WORKS DEPARTMENT

REV. BY	DATE
R.T.H.	11/99

MARCH 18, 1997  
DATE OF APPROVAL

SEWAGE PUMP STATION  
WET WELL & VALVE VAULT  
PLAN VIEW DETAILS

US-20A

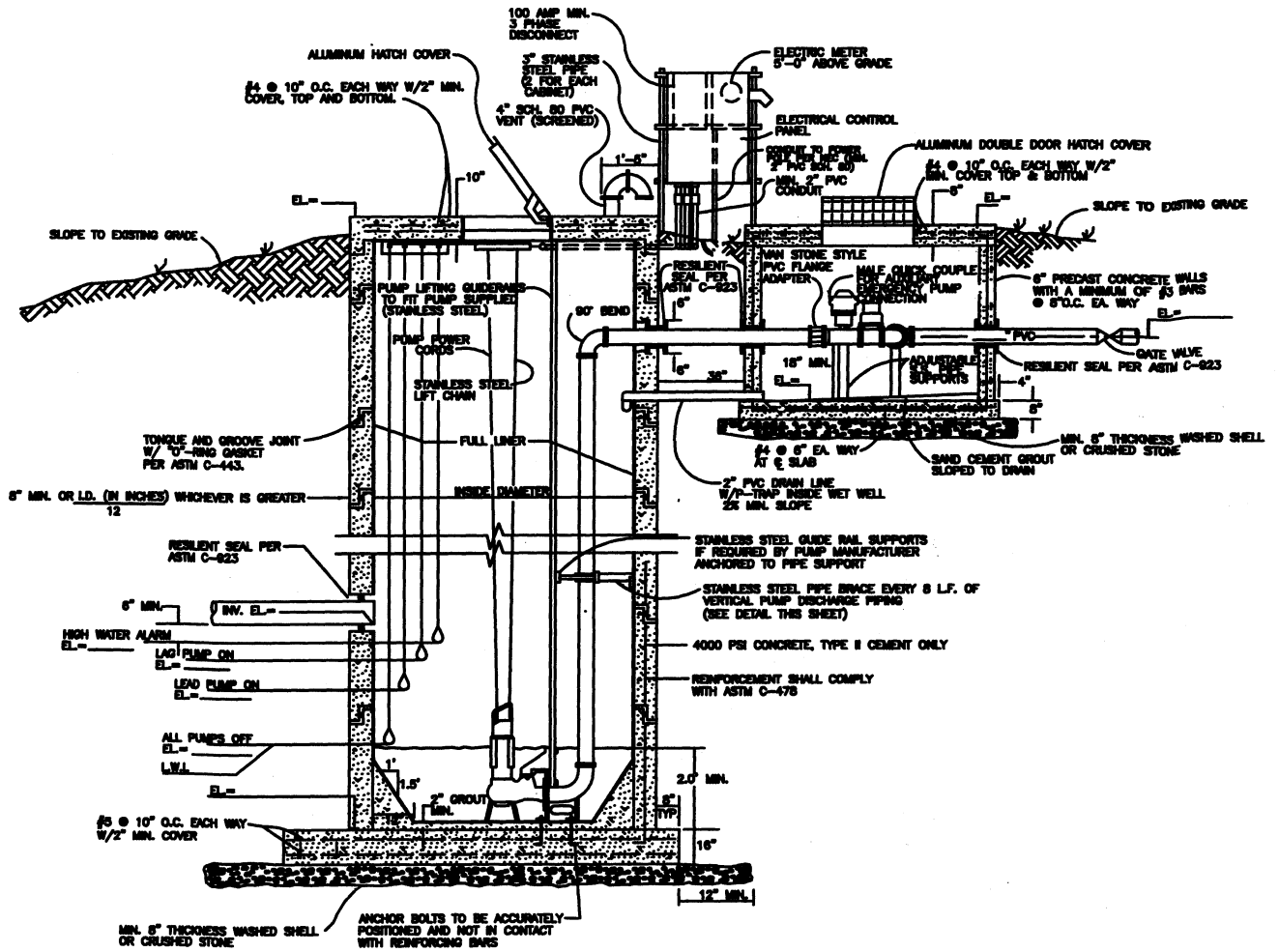

SECTION X-X

FOR PLAN VIEW  
SEE SHEET US-20A

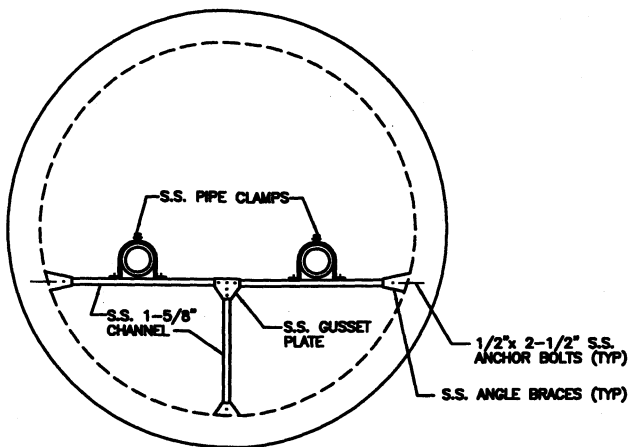

WET WELL PIPE BRACING DETAIL

PUMP DATA AND DESIGN CHARACTERISTICS	
NUMBER OF PUMPS	
DESIGN CAPACITY PER PUMP, G.P.M.	
TOTAL DYNAMIC HEAD, FT.	
MIN. EFF. AT DESIGN CAPACITY %	
HORSEPOWER PER PUMP, H.P.	
SHUT-OFF HEAD, FT.	
MAX. SIZE SOLIDS, IN.	
DISCHARGE SIZE, IN.	
PUMP MANUF. & MODEL NUMBER	
IMPELLER DIAMETER, IN.	
PUMP R.P.M.	
ELECT. SVC- VOLTAGE & PHASE	
FORCE MAIN- LENGTH, DIAMETER & MATERIAL	
FORCE MAIN DISCHARGE ELEV. & HIGHEST EL.	

MANATEE COUNTY  
PUBLIC WORKS DEPARTMENT

REV. BY	DATE
R.T.H.	11/99

MARCH 18, 1997  
DATE OF APPROVAL

SEWAGE PUMP STATION  
WET WELL & VALVE VAULT  
SECTIONAL VIEW DETAILS

US-20B

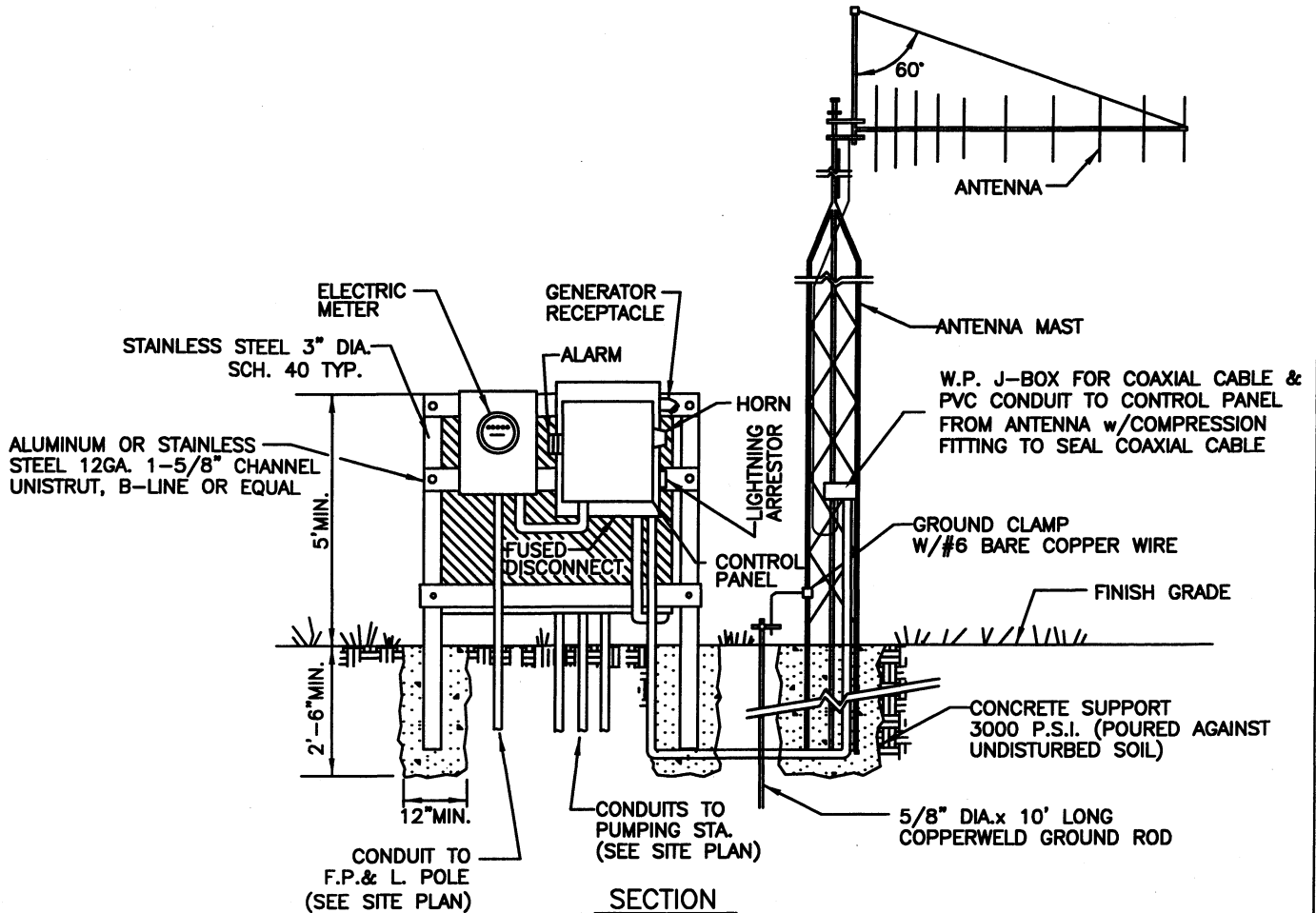
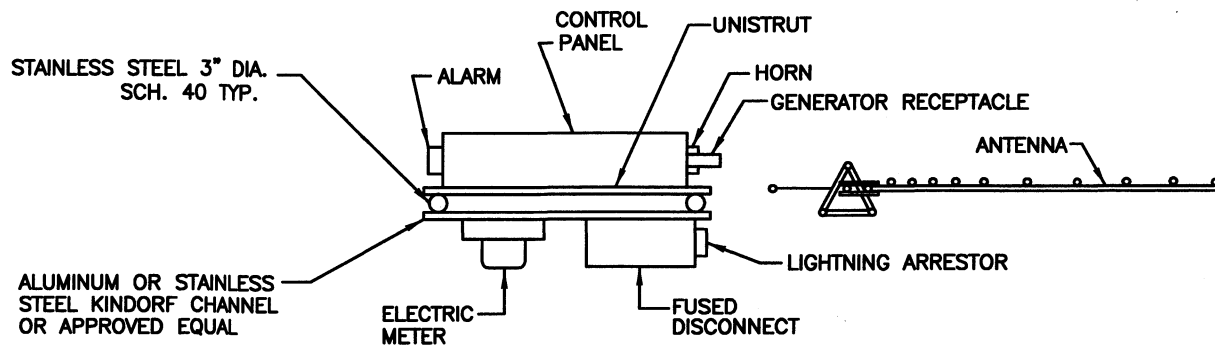

SECTION  
TYPICAL SERVICE ENTRANCE STRUCTURE

**NOTES:**

1. ALL EQUIPMENT FURNISHED FOR THE PUMP STATION SHALL CONFORM TO MANATEE COUNTY PUBLIC WORKS DEPARTMENT STANDARDS.
2. POWER TO BE SUPPLIED AS DIRECTED, THE CONTRACTOR SHALL BE RESPONSIBLE FOR ALL COSTS ASSOCIATED WITH PROVIDING TEMPORARY AND PERMANENT ELECTRICAL SERVICE.
3. ALL CONDUIT ENTERING THE CONTROL PANEL SHALL BE SEALED WITH INDUSTRIAL FOAM.
4. ALL P.V.C. CONDUIT SHALL BE SCHEDULE 80.
5. CONTROL AND FLOW METER ENCLOSURE TO BE NEMA 3R 304 STAINLESS STEEL WITH RAIN SHIELD.
6. FLOW METER WITH ABOVE GROUND TRANSMITTER IN WEATHER PROOF HOUSING SHALL BE INSTALLED FOR ALL STATIONS DESIGNED TO PUMP 500 GALS/MIN OR HIGHER, WITH VARIABLE SPEED PUMPING SYSTEMS.

<b>MANATEE COUNTY</b> PUBLIC WORKS DEPARTMENT		<b>SEWAGE PUMP STATION</b> <b>METER &amp; ELECTRICAL</b> <b>DETAILS</b>	<b>US-20C</b>
REV. BY R.T.H.	DATE 11/99		
MARCH 18, 1997 DATE OF APPROVAL			

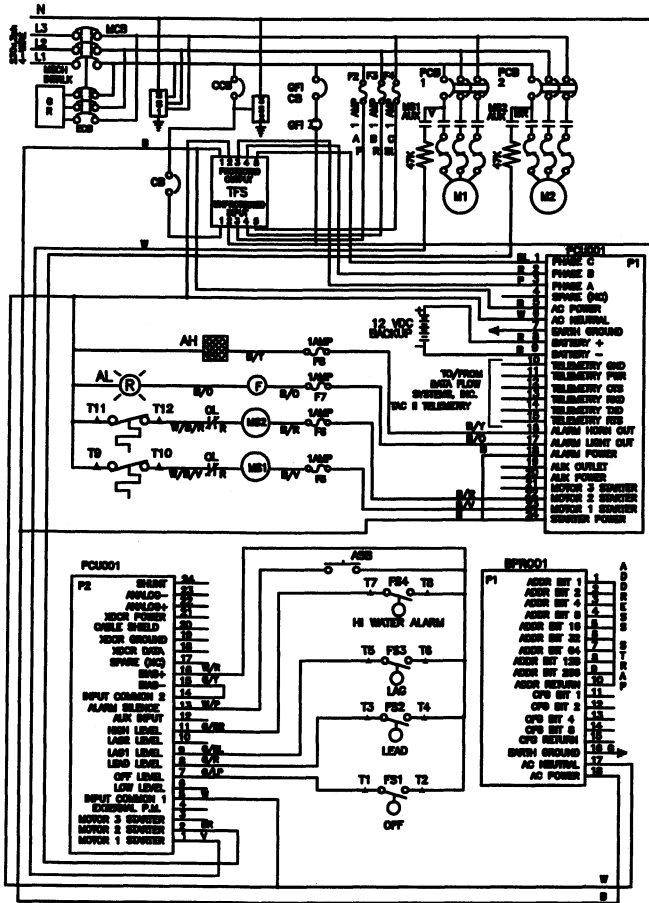

**BILL OF MATERIALS**

ENC	ENCLOSURE	HOFFMAN, A-36H3012SSLP 304SS
MCB	MAIN CIRCUIT BREAKER	SQ-D, QOU
ECB	EMERGENCY CIRCUIT BREAKER	SQ-D, QOU
PCB	PUMP CIRCUIT BREAKER	SQ-D, QOU
CCB	CONTROL CIRCUIT BREAKER	SQ-D, QOU115
OCB	GFI CIRCUIT BREAKER	SQ-D, QOU115
MS1,2	STARTER	FURNAS, 14DSF32AF51
GR	GENERATOR RECEPTACLE	RUSSELL STOLL, JRSB1044FR
AH	ALARM HORN	FEDERAL, 350-WB-120
AL	ALARM LIGHT	INGRAM, LR0B-40
F	FLASHER	INGRAM, FL-120-60
ASB	ALARM SILENCE BUTTON	SQ-D, 9001 SKR1BH5
GFI	CONVENIENCE RECEPTACLE	LEVITON, 6586-1

**ITEMS PROVIDED BY OTHERS**

PCU	PUMP CONTROL UNIT	DATA FLOW, DFS PCU001 W/TAC PAC
CB	CIRCUIT BREAKER	E-T-A, ETA-42-01
F2-8	FUSE AND HOLDER	WAGO, DFS-00271-003-9, 1AMP SB
47K	RESISTOR BLOCK	WAGO, DFS-00271-003-1
TFS	TRANSIENT FILTER SHIELD	DATA FLOW TFS001-02
12VDC	BATTERY BACKUP	YUASA, NP2.6-12 12 VDC @ 2.6AM
SS1	230V SURGE SUPPRESSOR (TPS001)	DITEK, DFS PN# 005-0082
SS2	120V SURGE SUPPRESSOR (SPS001)	DITEK, DFS PN# 005-0061

**COLOR CODE**

SYMBOL	COLOR
B	BLACK
W	WHITE
G	GREEN
BL	BLUE
R	RED
P	PINK
V	VIOLET
BR	BROWN
B/Y	BLACK/YELLOW
B/O	BLACK/ORANGE
B/R	BLACK/RED
B/V	BLACK/VIOLET
G/P	GREEN/PINK
G/R	GREEN/RED
G/BL	GREEN/BLUE
G/BR	GREEN/BROWN
W/P	WHITE/PINK
G/Y	GREEN/YELLOW
W/R	WHITE/RED
W/B/Y	WHITE/BLACK/YELLOW
W/BR	WHITE/BLACK/RED

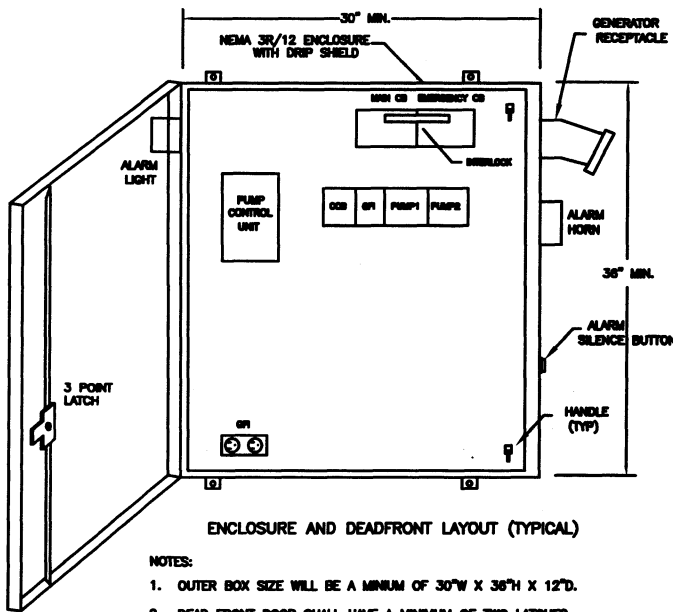
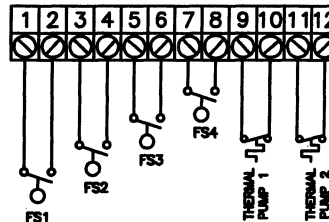

- NOTES:
1. OUTER BOX SIZE WILL BE A MINIMUM OF 30"W X 36"H X 12"D.
  2. DEAD FRONT DOOR SHALL HAVE A MINIMUM OF TWO LATCHES

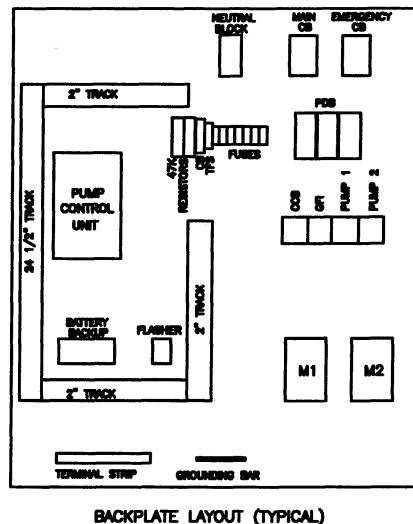

MANATEE COUNTY  
PUBLIC WORKS DEPARTMENT

SEWAGE PUMP STATION  
CONTROL PANEL  
DETAILS (230v)

US-20D

REV.BY	DATE

NOVEMBER 1, 1999  
DATE OF APPROVAL

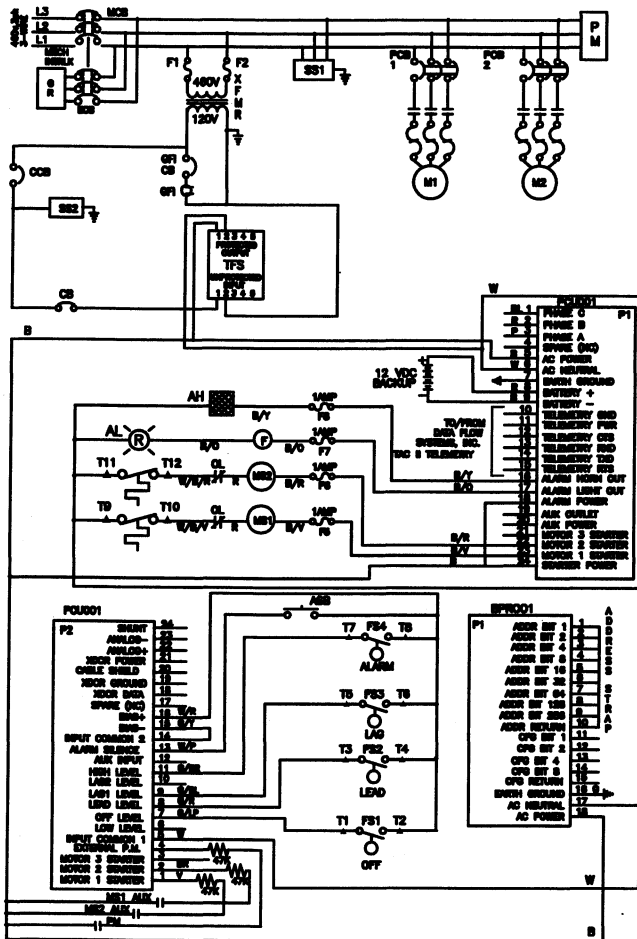

**BILL OF MATERIALS**

ENC	ENCLOSURE	HOFFMAN, A-48H3612SSLP
MCB	MAIN CIRCUIT BREAKER	SO-D, FAL
ECB	EMERGENCY CIRCUIT BREAKER	SO-D, FAL
PCB	PUMP CIRCUIT BREAKER	SO-D, FAL
CCB	CONTROL CIRCUIT BREAKER	SO-D, QOU115
GF1	GF1 CIRCUIT BREAKER	SO-D, QOU115
MS1,2	STARTER	SO-D, B536
GR	GENERATOR RECEPTACLE	RUSSELL STOLL, JRSB22034HR
AH	ALARM HORN	FEDERAL, 350-W3-12D
AL	ALARM LIGHT	INGRAM, LRD3-40
F	FLASHER	INGRAM, FL-120-60
ASB	ALARM SILENCE BUTTON	SO-D, 9001 SKR1BH5
GF1	CONVENIENCE RECEPTACLE	LEVITON, 6568-1
XFMR	TRANSFORMER	SO-D, 7410 JS1F
F1,2	FUSES	BUSS, FNQ10
PM	PHASE MONITOR	DIVERSIFIED, SLA-440-ASA

**ITEMS PROVIDED BY OTHERS**

PCU	PUMP CONTROL UNIT	DATA FLOW, DFS PCU001 W/TAC PAC
CB	CIRCUIT BREAKER	E-T-A, ETA-42-01
F4-7	FUSE AND HOLDER	WAGO, DFS-00271-003-9, 1AMP SB
47K	RESISTOR BLOCK	WAGO, DFS-00271-003-1
TFS	TRANSIENT FILTER SHIELD	DATA FLOW TFS001-02
12VDC	BATTERY BACKUP	YUASA, NP2.6-12 12 VDC @ 2.6AM
SS1	480V SURGE SUPPRESSOR (TPS001)	DITEK, DTK-480-3CM
SS2	120V SURGE SUPPRESSOR (SPS001)	DITEK, DFS PNF 005-0061

**COLOR CODE**

SYMBOL	COLOR
B	BLACK
V	WHITE
G	GREEN
L	BLUE
R	RED
P	PINK
V	VIOLET
BR	BROWN
B/Y	BLACK/YELLOW
B/O	BLACK/ORANGE
B/R	BLACK/RED
B/V	BLACK/VIOLET
G/LP	GREY/LIGHT PINK
G/R	GREY/RED
G/BL	GREY/BLUE
G/BR	GREY/BROWN
W/P	WHITE/PINK
G/Y	GREY/YELLOW
W/R	WHITE/RED
W/B/V	WHT/BLK/VIOLET
W/BR	WHT/BLK/RED

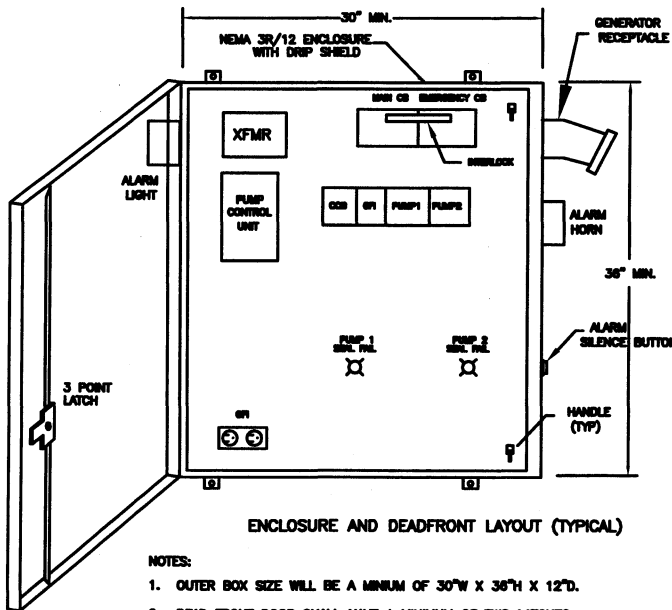
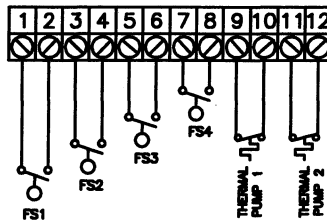

- NOTES:**
1. OUTER BOX SIZE WILL BE A MINIMUM OF 30" X 36" X 12".
  2. DEAD FRONT DOOR SHALL HAVE A MINIMUM OF TWO LATCHES

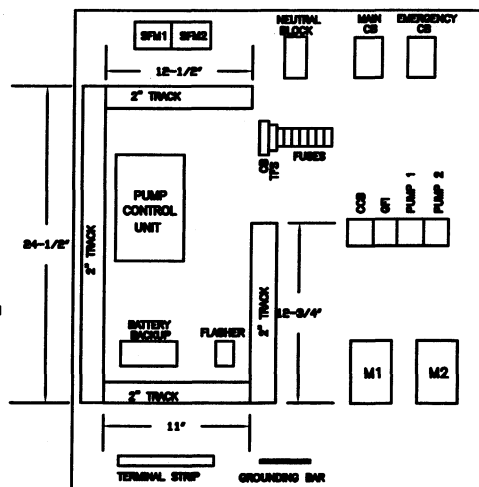

**BACKPLATE LAYOUT (TYPICAL)**

**MANATEE COUNTY  
PUBLIC WORKS DEPARTMENT**

**SEWAGE PUMP STATION  
CONTROL PANEL  
DETAILS (460v)**

**US-20E**

REV. BY    DATE

NOVEMBER 1, 1999  
DATE OF APPROVAL

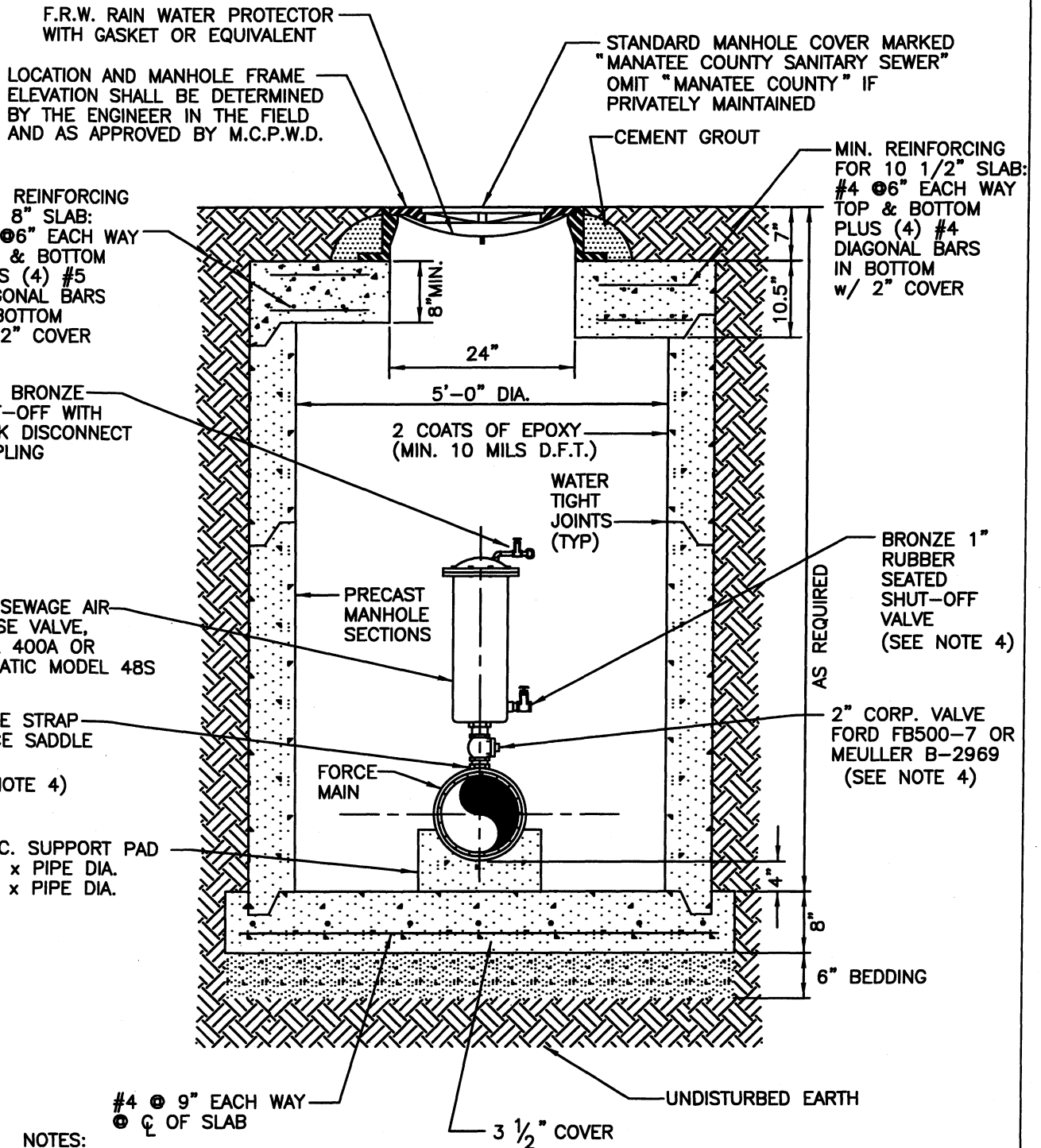

**NOTES:**

1. WHERE POSSIBLE ARV IS TO BE MOUNTED ABOVE GROUND IN STAINLESS STEEL CABINET.
2. TO PREVENT DAMAGE TO VALVE FROM TIPPED MANHOLE COVERS IN SHALLOW BOXES IT MAY BE NECESSARY TO OFFSET VALVE FROM CENTER LINE.
3. AIR RELEASE VALVES WHERE REQUIRED ON 4" AND LARGER FORCE MAINS.
4. ARV TO BE SIZED ACCORDING TO MANUFACTURER'S RECOMMENDATION FOR FORCE MAIN SIZE.
5. ALL PIPE STUBS, NIPPLES AND HARDWARE TO BE 304 STAINLESS STEEL.
6. WHERE AIR RELEASE VALVE IS FURTHER THAN 12' FROM CURB OR SHOULDER OF ROADWAY, SERIES H1R3030 ACCESS DOOR OR APPROVED EQUAL MAY BE USED.

MANATEE COUNTY  
PUBLIC WORKS DEPARTMENT

REV. BY	DATE
RTH	11/99

MARCH 18, 1997  
DATE OF APPROVAL

BELOW GRADE  
AIR RELEASE VALVE

US-21

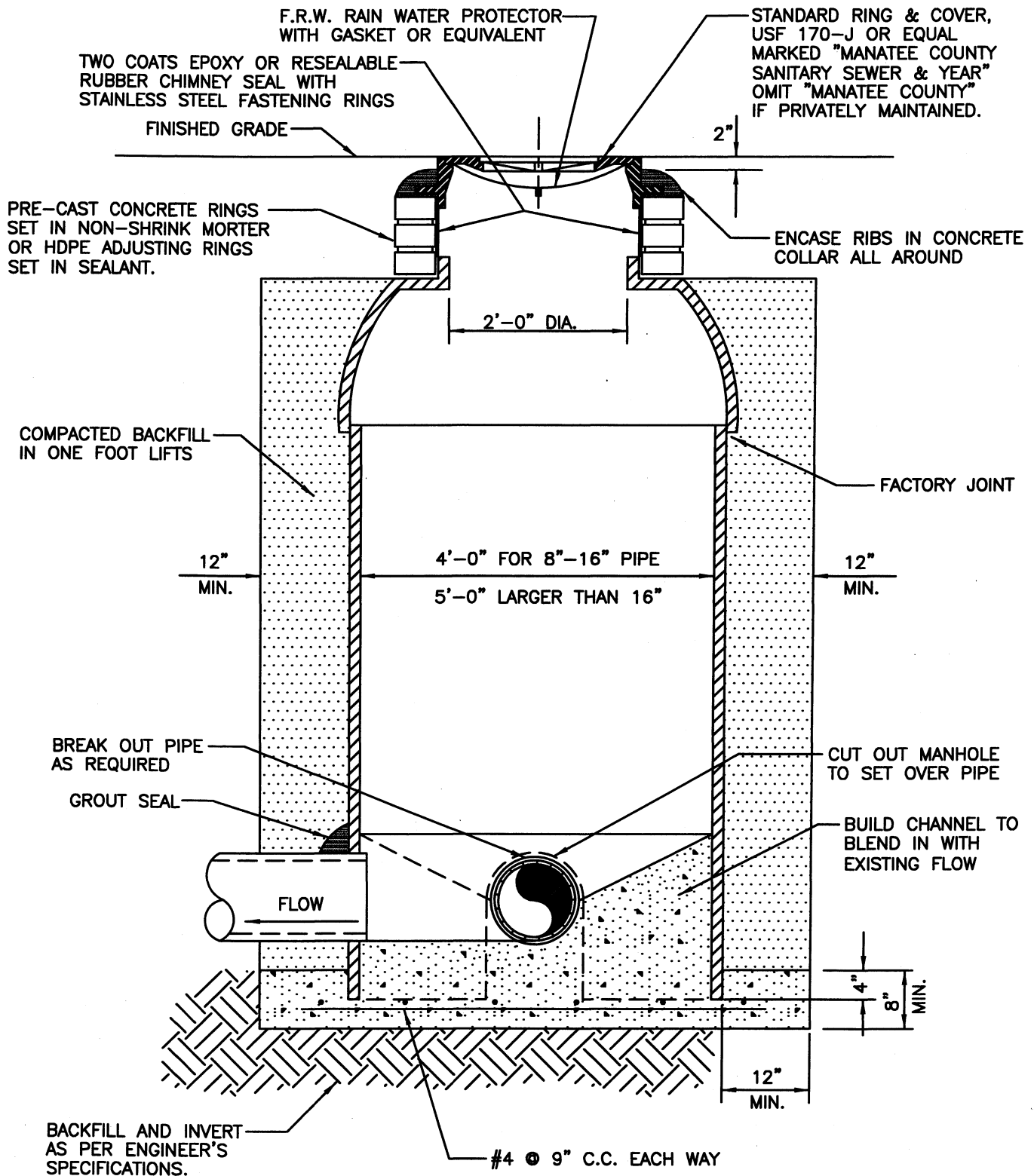

**NOTES:**

1. FIBERGLASS MANHOLE SHALL BE DESIGNED AS TRAFFIC BEARING (H20+30%) AND TO RESIST FLOTATION WITH GROUND WATER LEVEL AT FINISHED GRADE.
2. THICKNESS OF FIBERGLASS MANHOLE SHALL BE DETERMINED BY CALCULATIONS SUBMITTED TO THE ENGINEER IN ACCORDANCE WITH MANATEE COUNTY SPECIFICATIONS FOR TRAFFIC BEARING MANHOLES, BUT IN NO CASE WILL THE MINIMUM THICKNESS BE LESS THAN 3/8"

<b>MANATEE COUNTY</b> PUBLIC WORKS DEPARTMENT		<b>FIBERGLASS</b> <b>DOGHOUSE</b> <b>MANHOLE</b>	<b>US-22</b>
REV. BY	DATE	<b>MARCH 18, 1997</b> DATE OF APPROVAL	
RTH	11/99		



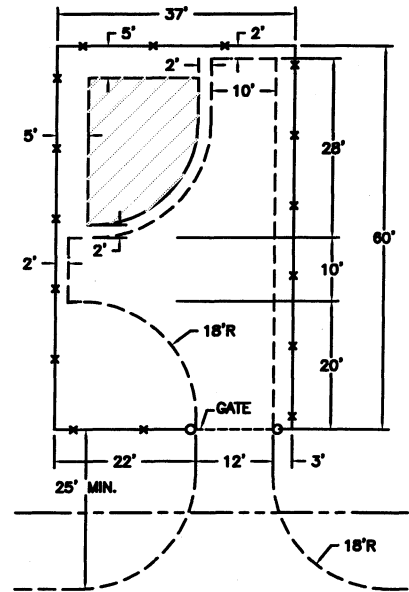
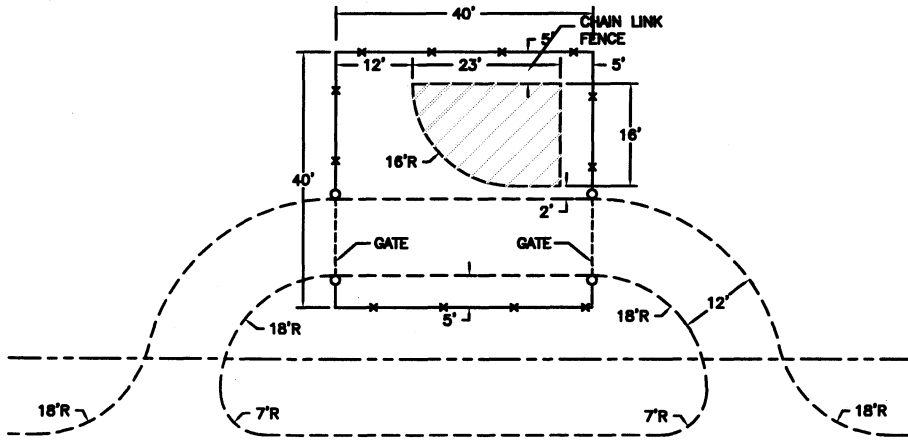
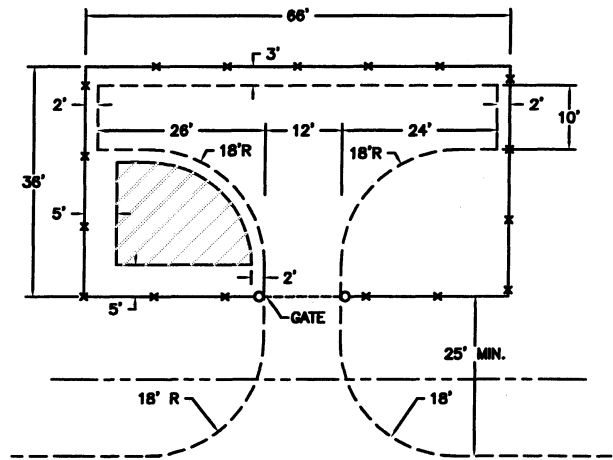
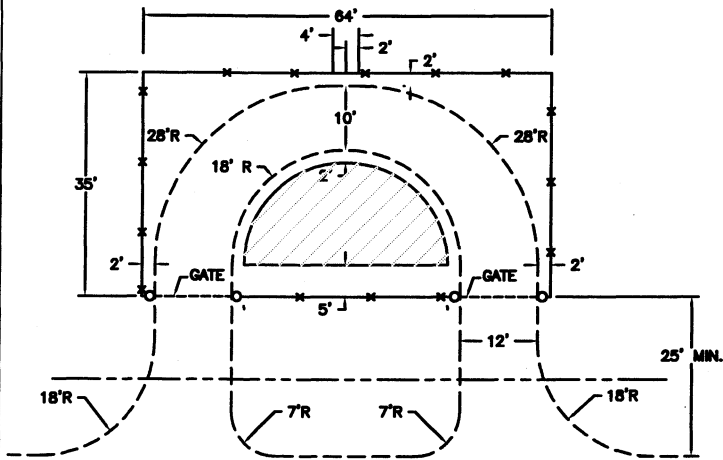



**PAVING SHALL CONSIST OF:**

- A) 1-1/2" TYPE S-III ASPHALTIC CONCRETE ON 6" SHELL OR CRUSHED CONCRETE BASE ON 7" STABILIZED SUB-BASE, MIN. LBR = 35
- B) 5" THICK REINFORCED CONCRETE ON 7" STABILIZED SUB-BASE w/ 98% COMPACTION, REINFORCEMENT TO BE #4 @ 12" O.C. EACH WAY

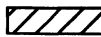
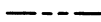
CONC.  $f'_c$  = 3000 P.S.I. PER F.D.O.T. SPECS. & PROVIDE 3/4" DEEP SAWCUT CONTROL JOINT @ 20' MAX. SPACING

-  INDICATES LIFT STATION CONSTRUCTION ENVELOPE
-  RIGHT-OF-WAY
-  CHAIN LINK FENCE
-  EDGE OF PAVEMENT OR BACK OF CURB

**NOTE:**

LIFT STATION SITING & LANDSCAPING SHALL BE IN ACCORDANCE WITH THE CURRENT MANATEE COUNTY LAND DEVELOPMENT CODES. ANY ADDITIONAL PLANTING AREA REQUIRED FOR SCREENING SHRUBBERY OUTSIDE OR INSIDE THE FENCE SHALL BE INCLUDED AS PART OF THE LIFT STATION SITE.

**MANATEE COUNTY  
PUBLIC WORKS DEPARTMENT**

REV. BY	DATE
R.T.H.	11/99

**MARCH 18, 1997**  
DATE OF APPROVAL

**MINIMUM ACCESS/EGRESS  
REQUIREMENTS FOR LIFT  
STATIONS ADJACENT TO  
BUSY THOROUGHFARES**

**US-23**

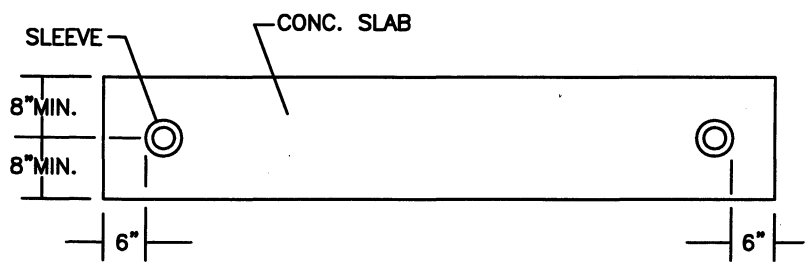
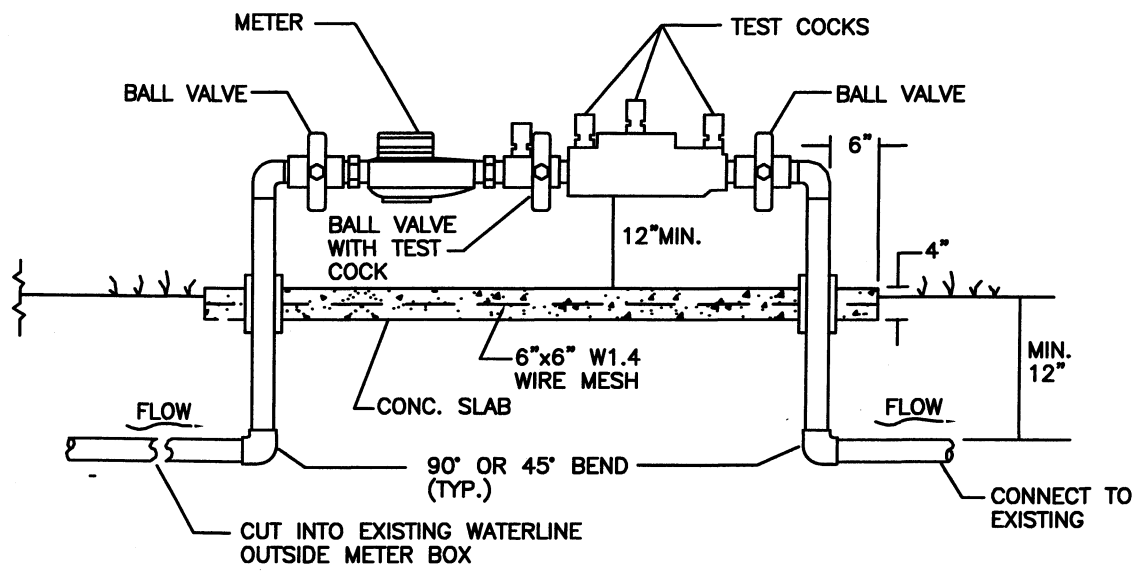

NOTES:

1. BOTTOM OF BACKFLOW DEVICE MUST BE 12" ABOVE CONCRETE PAD. CONCRETE PAD MUST BE 1" ABOVE FINISHED GRADE.
2. BACKFLOW DEVICE MUST BE INSTALLED DOWNSTREAM OF METER, AS CLOSE TO METER AS POSSIBLE.
3. COPPER PIPE TYPE "L" OR "K" OR BRASS PIPE MINIMUM SCHEDULE 40 SHALL BE USED TO A MINIMUM DEPTH OF 12" BELOW GRADE.
4. PIPES PASSING THROUGH OR ENCASED IN CONCRETE MUST BE PROPERLY PROTECTED AND SLEEVED.
5. THE SYSTEM MUST MEET ALL REQUIRMENTS OF THE MANATEE COUNTY PLUMBING CODE (LATEST EDITION) AND THE MANATEE COUNTY BACKFLOW PREVENTION CODE (LATEST EDITION).
6. ALL PIPING FROM BACKFLOW DEVICE TO THE FIRST ATMOSPHERIC OPENING OR TO EACH BRANCH VALVE, MUST BE COLOR CODED BLUE FOR POTABLE WATER OR PURPLE FOR RECLAIMED WATER.
7. ALL EXPOSED CONCRETE EDGES SHALL BE CHAMFERED 1/2".

<b>MANATEE COUNTY</b> PUBLIC WORKS DEPARTMENT		<b>5/8" WATER METER &amp; BACKFLOW          PREVENTER ABOVE GROUND          DETAIL FOR LIFT STATIONS</b>	<b>US-24</b>
REV. BY	DATE		
NOVEMBER 1, 1999 DATE OF APPROVAL			

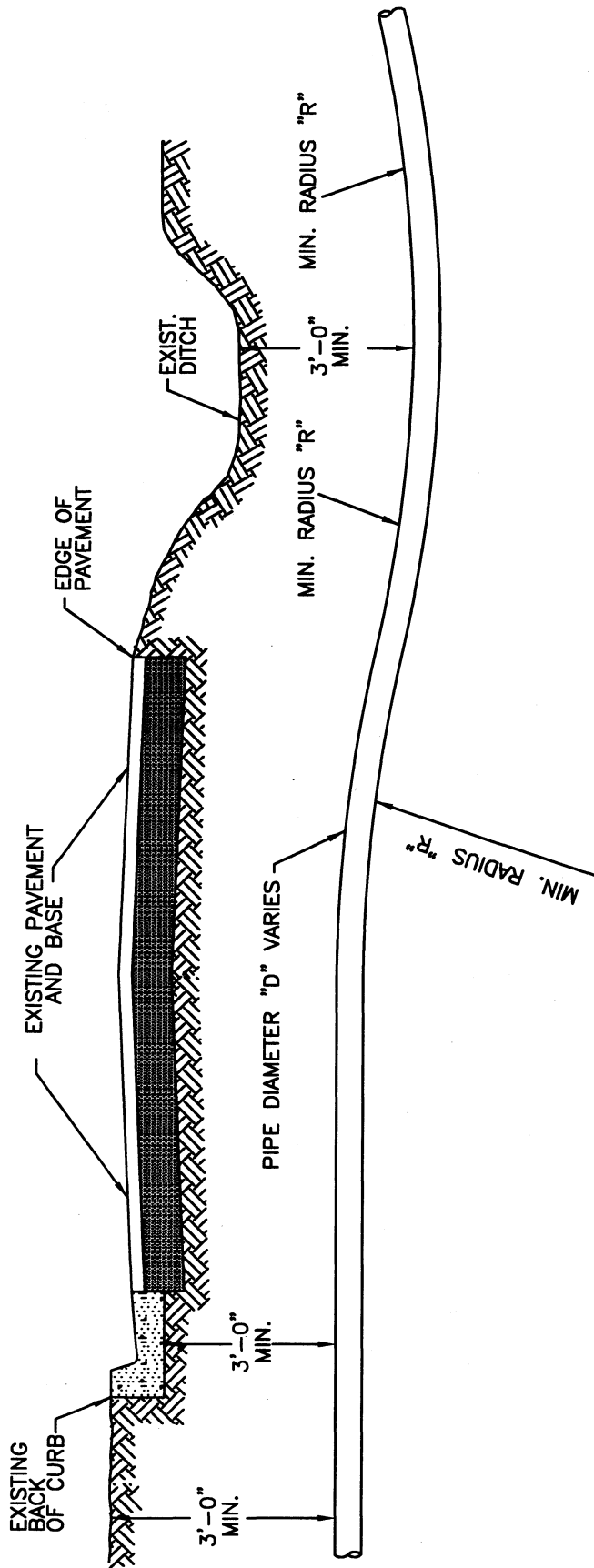

PIPE DIAMETER "D" IN INCHES	MIN. RADIUS FOR PE PIPE IN FEET	MIN. RADIUS "R" FOR SDR-11	MIN. RADIUS "R" FOR SDR-9
2	4		5.5
3	6		8.3
4	8		11.0
6	12		16.5
8	16		22.0
10	20		27.5
12	24		33.0
16	32		44.0
18	36		49.5
20	40		55.0

ALL POLYETHYLENE PIPING SHALL MEET MANATEE COUNTY STANDARDS AND SPECIFICATIONS

SDR-9, CLASS 200 FOR POTABLE WATER & RECLAIMED WATER  
 SDR-11, CLASS 160 FOR SANITARY FORCE MAINS  
 COLOR CODED BLUE FOR POTABLE WATER  
 COLOR CODED PURPLE FOR RECLAIMED WATER  
 COLOR CODED GREEN FOR SANITARY FORCE MAIN

MANATEE COUNTY  
 PUBLIC WORKS DEPARTMENT

REV. BY	DATE

NOVEMBER 1, 1999  
 DATE OF APPROVAL

DIRECTIONAL BORE  
 ROADWAY CROSSING

US-25

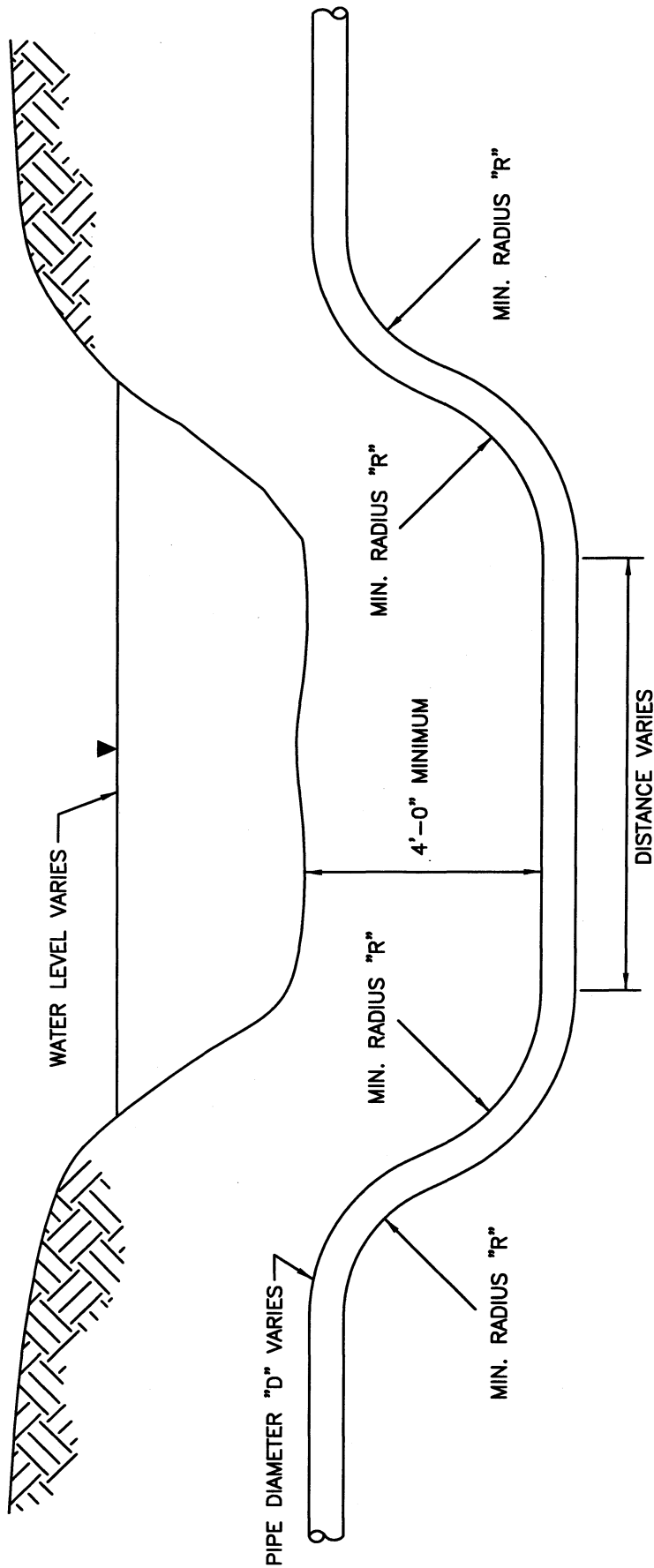

PIPE DIAMETER "D" IN INCHES	MIN. RADIUS FOR PE PIPE IN FEET	MIN. RADIUS "R" FOR SDR-11	MIN. RADIUS "R" FOR SDR-9
2	4	5.5	
3	6	8.3	
4	8	11.0	
6	12	16.5	
8	16	22.0	
10	20	27.5	
12	24	33.0	
16	32	44.0	
18	36	49.5	
20	40	55.0	

ALL POLYETHYLENE PIPING SHALL MEET MANATEE COUNTY STANDARDS AND SPECIFICATIONS

SDR-9, CLASS 200 FOR POTABLE WATER & RECLAIMED WATER  
 SDR-11, CLASS 160 FOR SANITARY FORCE MAINS  
 COLOR CODED BLUE FOR POTABLE WATER  
 COLOR CODED PURPLE FOR RECLAIMED WATER  
 COLOR CODED GREEN FOR SANITARY FORCE MAIN

MANATEE COUNTY  
 PUBLIC WORKS DEPARTMENT

REV. BY	DATE

NOVEMBER 1, 1999  
 DATE OF APPROVAL

DIRECTIONAL BORE  
 CANAL CROSSING

US-26

TO CONFORM TO ASTM A-48 OR FED. SPEC. QQ-I-652-B FRAME #160, COVER #145, USE 170-J OR APPROVED EQUAL. COVER TO BE MARKED "MANATEE COUNTY SANITARY SEWER & YEAR" OMIT "MANATEE COUNTY" IF PRIVATELY MAINTAINED.

RIM ELEVATION INDICATED ON PLAN

F.R.W. RAIN WATER PROTECTOR WITH GASKET OR EQUIVALENT.

FINISH GRADE

ENCASE RIBS IN CONCRETE COLLAR ALL AROUND

PRE-CAST M.H. SHALL CONFORM TO ASTM C-478 LATEST REV, TYPE II CONCRETE, 4,000 P.S.I. 28 DAY COMPRESSIVE STRENGTH

PRE-CAST CONCRETE RINGS SET IN NON-SHRINK MORTAR AND CAULKED INSIDE & OUTSIDE OR HDPE ADJUSTING RINGS SET IN SEALANT.

TONGUE & GROOVE JOINT W/"O"-RING GASKET. ALL JOINTS SHALL MEET THE REQUIREMENTS FOR CONCRETE SEWER AND CULVERT PIPE USING RUBBER GASKETS (ASTM C-443)

FLEXIBLE GASKETS SHALL MEET THE REQUIREMENTS OF ASTM-443 IN ADDITION TO THESE GASKETS CONTRACTOR MAY AT HIS CHOICE, ADD AN EXTERIOR SEAL SUCH AS "WATER STOP RX," "ADEKA ULTRA SEAL," OR "CADILLOC SEALING BRANDS."

8" MIN. 4'-0" DIA. (8"-16" PIPE) 5'-0" DIA. (LARGER THAN 16") 8" MIN.

LIFT HOLES OR INSERTS SHALL NOT PENETRATE MANHOLE WALL

CHANNEL FLOW DETAILS

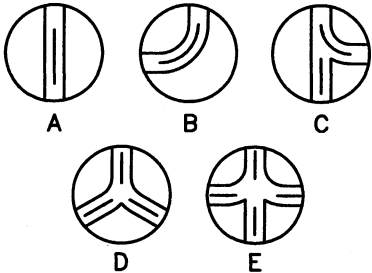

ALL PIPE OPENINGS SHALL HAVE RESILIENT PIPE TO MANHOLE SEALS PER ASTM C-923.

#4 @ 9" C.C. EACH WAY CENTERED

NOTE:

DROP MANHOLES, MANHOLES WITH OPPOSING FLOW (DETAIL E), MANHOLES RECEIVING A FORCE MAIN AND FIRST GRAVITY MANHOLE DOWNSTREAM OF MANHOLES RECEIVING A FORCE MAIN INCLUDING TOP AND BOTTOM SECTIONS SHALL HAVE AN APPROVED LINER.

MANATEE COUNTY  
PUBLIC WORKS DEPARTMENT

STANDARD PRE-CAST  
SANITARY SEWER MANHOLE  
FOR UNDISTURBED FLOW

US-3

REV. BY	DATE
RTH	11/99

MARCH 18, 1997  
DATE OF APPROVAL

TO CONFORM TO ASTM A-48 OR FED. SPEC. QQ-I-652-B FRAME #160, COVER #145, USE 170-J OR APPROVED EQUAL. COVER TO BE MARKED "MANATEE COUNTY SANITARY SEWER & YEAR" OMIT "MANATEE COUNTY" IF PRIVATELY MAINTAINED.

RIM ELEVATION INDICATED ON PLAN

F.R.W. RAIN WATER PROTECTOR WITH GASKET OR EQUIVALENT.

FINISH GRADE

PRE-CAST CONCRETE RINGS SET IN NON-SHRINK MORTAR OR HDPE ADJUSTING RINGS SET IN SEALANT.

ENCASE RIBS IN CONCRETE COLLAR ALL AROUND

APPROVED LINER SUCH AS WATER LOCK BY A-LOCK PRODUCTS

PRE-CAST M.H. SHALL CONFORM TO ASTM C-478 LATEST REV, TYPE II CONCRETE, 4,000 P.S.I. 28 DAY COMPRESSIVE STRENGTH

TONGUE & GROOVE JOINT W/"O"-RING GASKET. ALL JOINTS SHALL MEET THE REQUIREMENTS FOR CONCRETE SEWER AND CULVERT PIPE USING RUBBER GASKETS (ASTM C-443)

FLEXIBLE GASKETS SHALL MEET THE REQUIREMENTS OF ASTM-443 IN ADDITION TO THESE GASKETS CONTRACTOR MAY AT HIS CHOICE, ADD AN EXTERIOR SEAL SUCH AS "WATER STOP RX," "ADEKA ULTRA SEAL," OR "CADILLOC SEALING BRANDS."

APPROVED FULL INTEGRAL LINER CAST WITH WALL, BENCH & CHANNEL PRE-CAST CONCRETE SECTIONS AND SHALL BE ONE OF THE FOLLOWING MATERIALS:  
5mm FRP GU LINER,  
2.5mm PVC DURA-PLATE LINER,  
3mm HDPE AGRU LINER,  
2mm PP-R AGRU LINER OR APPROVED EQUAL.

INSIDE JOINTS SHALL BE SEALED WITH PREFORMED JOINT GASKET MATERIAL TO COMPLY WITH ASTM C-443 STANDARDS. MATERIAL SHALL BE APPLIED IN SUCH A MANNER TO OVERLAP APPROVED LINER AND ENSURE CONTINUOUS SEAL. UNDER NO CIRCUMSTANCES SHALL CONCRETE BE VISIBLE IN THE INSIDE JOINT. (IN REMEDIAL CASES THE ENGINEER MAY APPROVE SEALING JOINT WITH 100% SILICONE SEALANT GE CONTRACTOR SCS1000 AND NOMACO SOF ROD BACKER ROD OR APPROVED EQUAL).

7" MIN.

4'-0" DIA. (8"-16" PIPE)

5'-0" DIA. (LARGER THAN 16")

7" MIN.

CHANNEL FLOW DETAILS

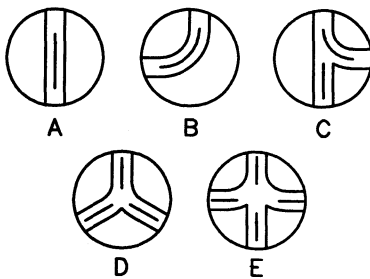

LIFT HOLES OR INSERTS SHALL NOT PENETRATE MANHOLE WALL

ALL PIPE OPENINGS SHALL HAVE RESILIENT PIPE TO MANHOLE SEALS PER ASTM C-923.

#4 @ 9"C.C. EACH WAY CENTERED

6"

8"

6" MIN. BEDDING

12" MIN.

NOTE:

DROP MANHOLES, MANHOLES WITH OPPOSING FLOW (DETAIL E), MANHOLES RECEIVING A FORCE MAIN AND FIRST GRAVITY MANHOLE DOWNSTREAM OF MANHOLES RECEIVING A FORCE MAIN INCLUDING TOP AND BOTTOM SECTIONS SHALL HAVE AN APPROVED LINER.

MANATEE COUNTY  
PUBLIC WORKS DEPARTMENT

STANDARD PRE-CAST  
SANITARY SEWER MANHOLE  
FOR TURBULENT FLOW

US-3A

REV. BY	DATE
RTH	11/99

MARCH 18, 1997  
DATE OF APPROVAL

STANDARD RING & COVER  
 USF 170-J OR EQUAL  
 MARKED "MANATEE COUNTY  
 SANITARY SEWER & YEAR"  
 OMIT "MANATEE COUNTY"  
 IF PRIVATELY MAINTAINED.

PRE-CAST CONCRETE RINGS  
 SET IN NON-SHRINK MORTAR  
 OR HDPE ADJUSTING RINGS  
 SET IN SEALANT.

**NOTE:**

IN LIEU OF THE FIBERGLASS  
 CONE A FLAT TOP SIMILAR  
 TO THAT SHOWN ON SHEET  
 US-5 BUT WITH A PROPERLY  
 ANCHORED LINER  
 MAY BE USED.

TONGUE & GROOVE JOINT  
 W/"O"-RING GASKET SHALL  
 CONFORM TO ASTM C-443  
 REF. US-3

**CHANNEL FLOW DETAILS**

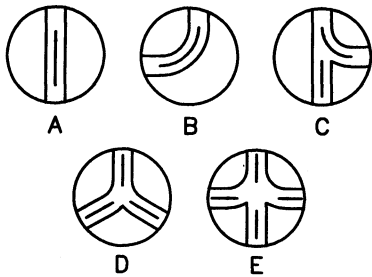

ALL PIPE OPENINGS SHALL  
 HAVE RESILIENT PIPE  
 TO MANHOLE SEALS  
 PER ASTM C-923.

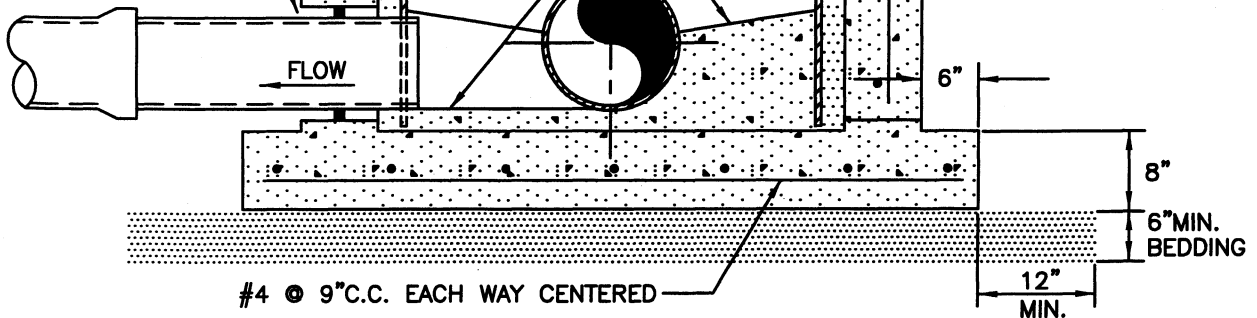

**NOTES:**

1. DROP MANHOLES, MANHOLES WITH OPPOSING FLOW (DETAIL E), MANHOLES RECEIVING A FORCE MAIN AND FIRST GRAVITY MANHOLE DOWNSTREAM OF MANHOLES RECEIVING A FORCE MAIN INCLUDING TOP AND BOTTOM SECTIONS SHALL HAVE AN APPROVED LINER. MANHOLES SHALL HAVE 8" MINIMUM WALL THICKNESS.
2. THICKNESS OF FIBERGLASS MANHOLE LINER SHALL BE DETERMINED BY CALCULATIONS SUBMITTED TO THE ENGINEER AND BE ADEQUATE TO RESIST HYDROSTATIC PRESSURES AND WHEEL LOADS WHERE APPLICABLE BUT SHALL NOT BE LESS THAN 1/4".

MANATEE COUNTY  
 PUBLIC WORKS DEPARTMENT

ALTERNATE DETAIL  
 SANITARY SEWER MANHOLE  
 FOR TURBULENT FLOW

US-3B

REV. BY	DATE
RTH	11/99

MARCH 18, 1997  
 DATE OF APPROVAL

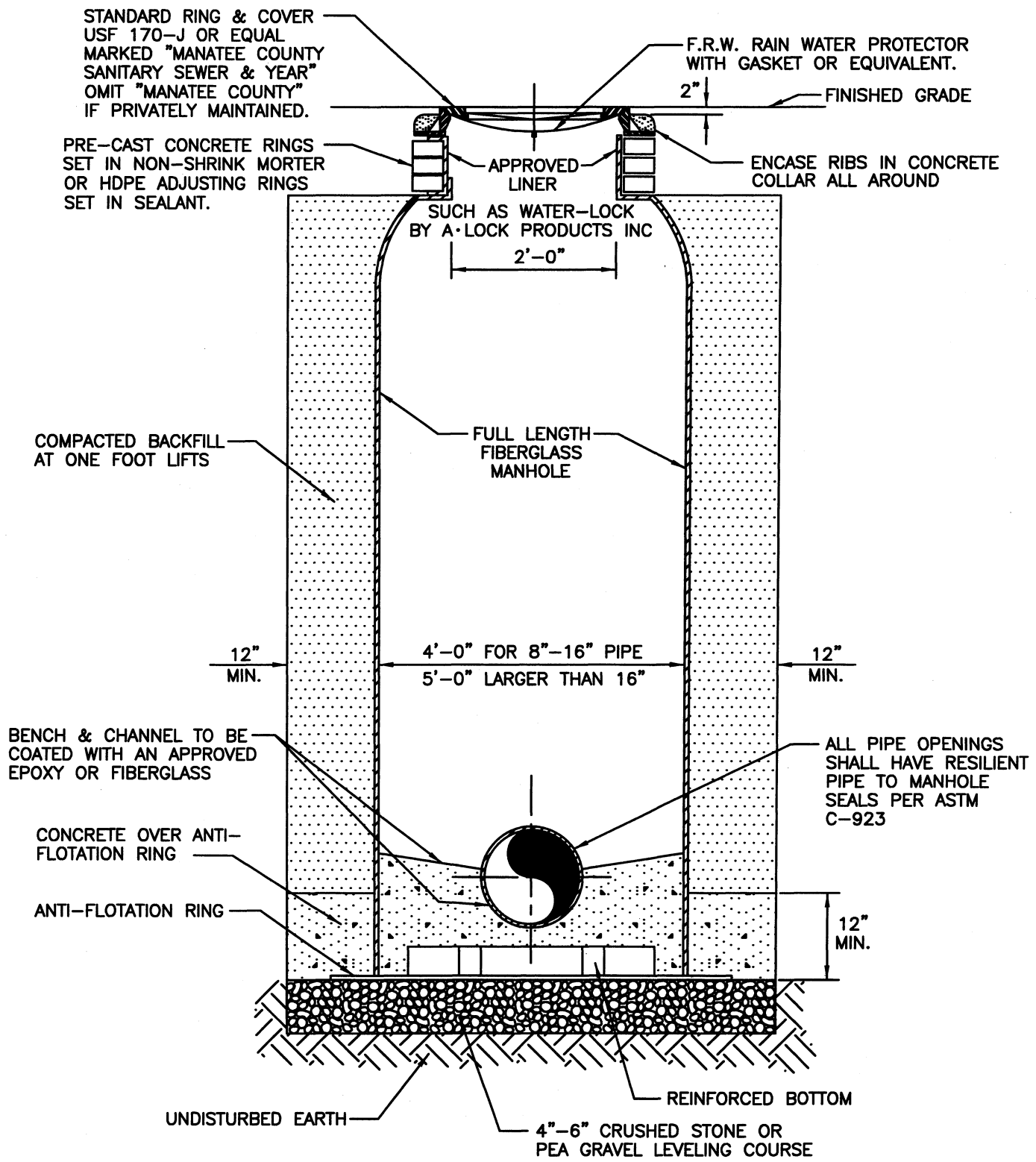

**NOTES:**

1. ALL FIBERGLASS MANHOLES SHALL BE DESIGNED AS TRAFFIC BEARING (H20+30% IMPACT) AND TO RESIST FLOTATION WITH GROUND WATER LEVEL AT FINISHED GRADE.
2. THICKNESS OF FIBERGLASS MANHOLES SHALL BE DETERMINED BY CALCULATIONS SUBMITTED TO THE ENGINEER IN ACCORDANCE WITH MANATEE COUNTY SPECIFICATIONS FOR TRAFFIC BEARING MANHOLES, BUT IN NO CASE WILL THE MINIMUM THICKNESS BE LESS THAN 3/8".

MANATEE COUNTY PUBLIC WORKS DEPARTMENT		STANDARD FIBERGLASS SANITARY SEWER MANHOLE	US-3C
REV. BY RTH	DATE 11/99		
DATE OF APPROVAL _____			





STANDARD MANHOLE COVER MARKED "MANATEE COUNTY" SANITARY SEWER & YEAR" OMIT "MANATEE COUNTY" IF PRIVATELY MAINTAINED.

RIM ELEVATION AS SHOWN ON PLANS

MIN. REINFORCING FOR 10 1/2" SLAB: #4 @ 6" EACH WAY TOP & BOTTOM PLUS (4) #4 DIAGONAL BARS IN BOTTOM w/ 2" COVER

ENCASE RIBS IN CONCRETE COLLAR ALL AROUND.

F.R.W. RAIN WATER PROTECTOR W/GASKET

FINISH GRADE

MIN. REINFORCING FOR 8" SLAB: #5 @ 6" EACH WAY TOP & BOTTOM PLUS (4) #5 DIAGONAL BARS IN BOTTOM w/ 2" COVER

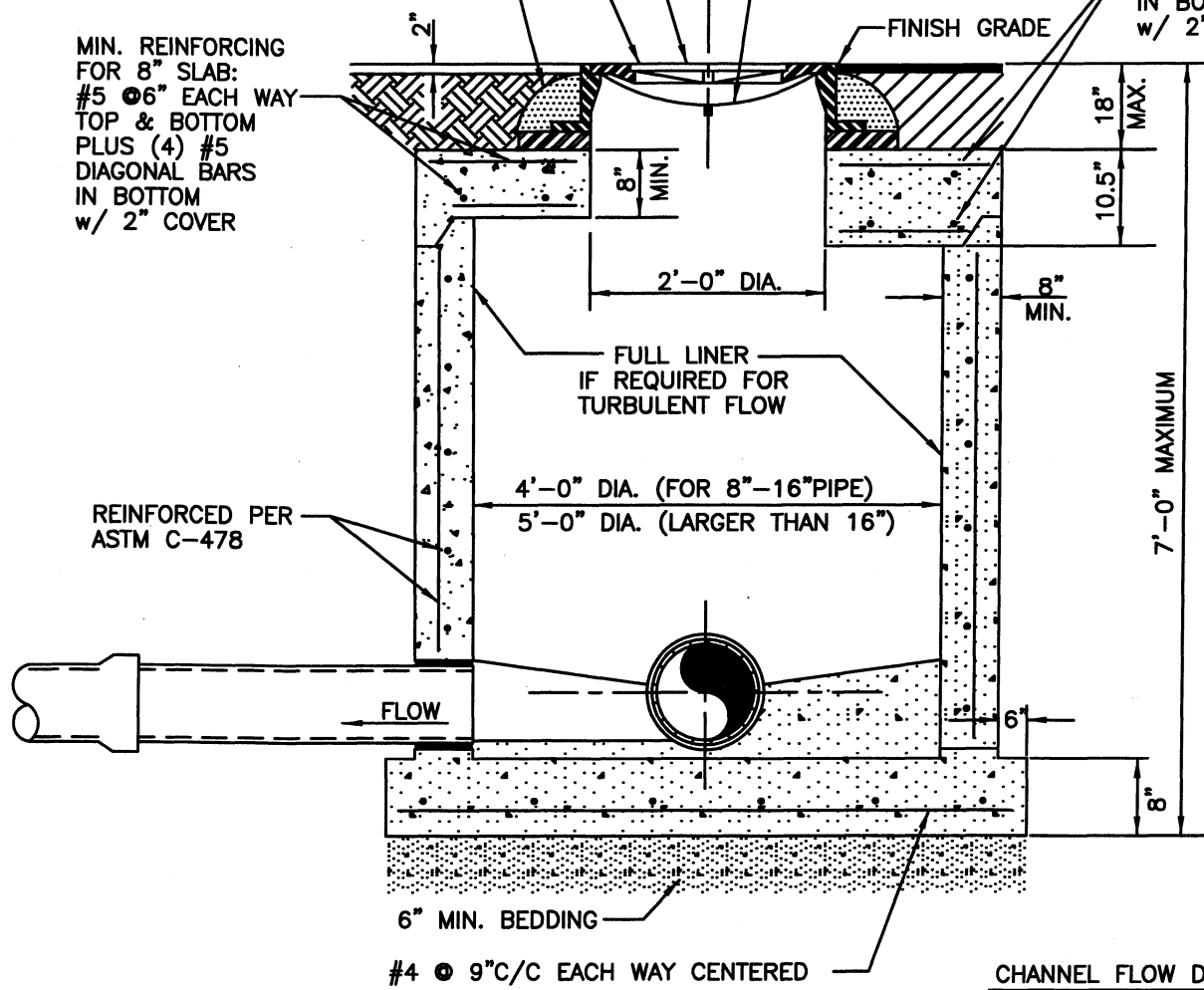

CHANNEL FLOW DETAILS

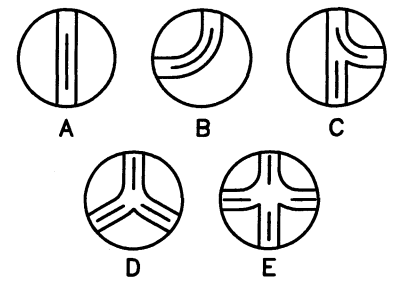

NOTES:

1. DROP MANHOLES, MANHOLES WITH OPPOSING FLOW (DETAIL E), MANHOLES RECEIVING A FORCE MAIN AND FIRST GRAVITY MANHOLE DOWNSTREAM OF MANHOLES RECEIVING A FORCE MAIN INCLUDING TOP AND BOTTOM SECTIONS SHALL HAVE AN APPROVED LINER.
2. FLEXIBLE GASKET CONNECTORS FOR CONNECTING PIPES SHALL MEET THE REQUIREMENTS OF ASTM C-923 OR LATEST REVISION, AND ARE REQUIRED IN ALL MANHOLES.
3. LIFT HOLES OR INSERTS SHALL NOT PENETRATE THE WALLS OF THE MANHOLES.
4. 24" MANHOLE OPENING TO BE OFFSET TO ONE SIDE AND CENTERED OVER PIPE.

MANATEE COUNTY PUBLIC WORKS DEPARTMENT		STANDARD PRE-CAST SHALLOW MANHOLE	US-5
REV. BY RTH	DATE 11/99		
MARCH 18, 1997 DATE OF APPROVAL			

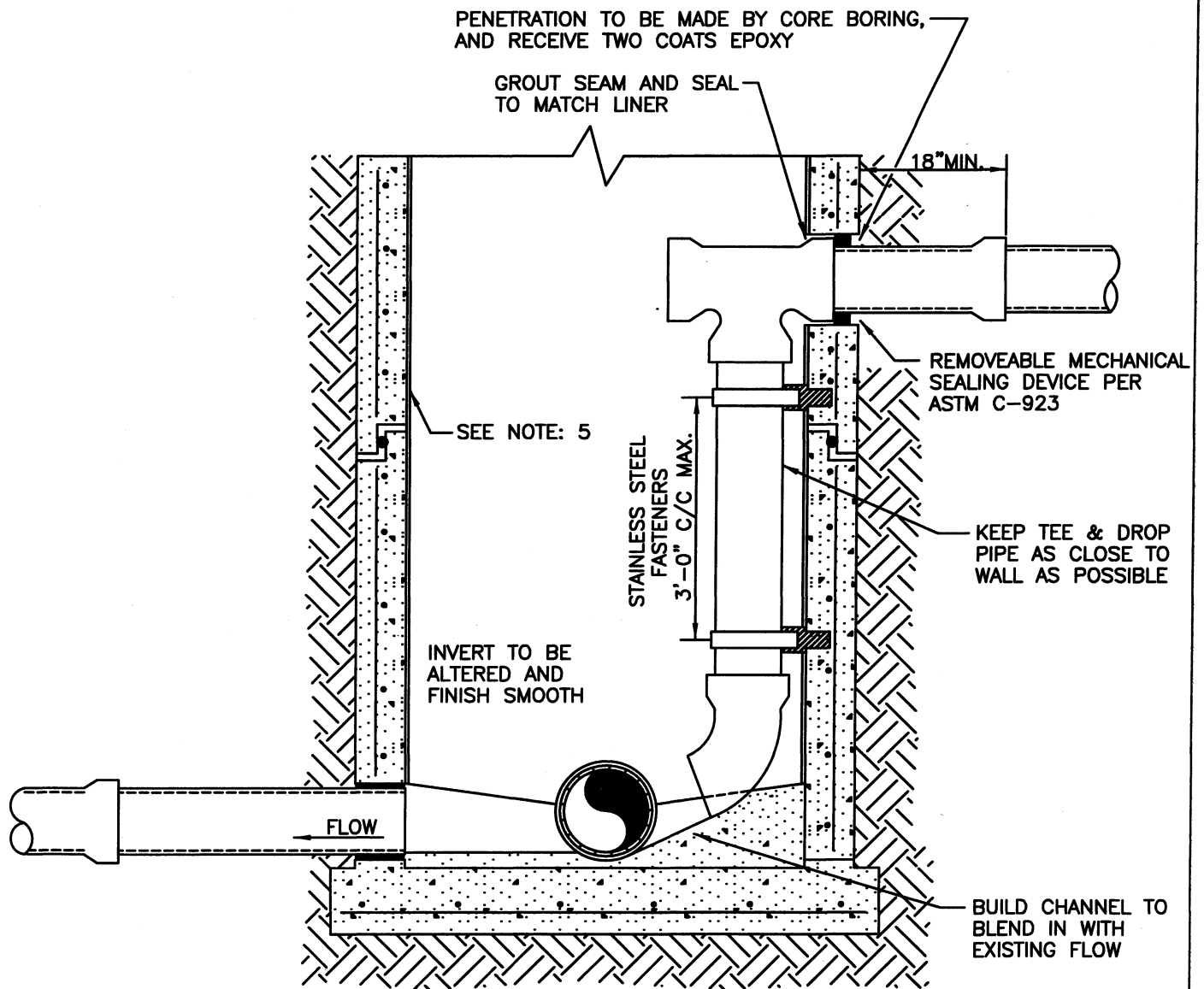

**NOTES:**

1. ALL PIPING ENTERING EXISTING STRUCTURES SHALL BE ACCOMPLISHED BY MECHANICAL ROTARY CORE BORING THE MANHOLE RISER. AFTER INSTALLATION OF PIPING, ALL PIPE OPENINGS SHALL HAVE RESILIENT PIPE TO MANHOLE SEALS PER ASTM C-923.
2. PVC PIPE AND FITTINGS SHALL BE ASTM D-3034 SDR 26.
3. ALL FERROUS MATERIALS SHALL BE FULLY COATED IN AND OUT WITH 2 COATS OF KOPPERS 300-M EPOXY OR EQUAL 8 MILS DFT, TOGETHER WITH THE PENETRATION THROUGH THE STRUCTURE WALL. STAINLESS STEEL SHALL NOT BE COATED.
4. ADAPTERS CONNECTING DIFFERENT PIPING MUST BE MANUFACTURED FOR THIS PURPOSE; SUBMIT DETAILS TO ENGINEER FOR APPROVAL.
5. THIS IS AN INTERCEPT MANHOLE AND MUST BE LINED WITH APPROVED LINER (SEE DETAIL US-3A).
6. INSIDE DROP MANHOLES ARE REQUIRED WHEN THE VERTICAL DISTANCE BETWEEN THE LOWEST EXISTING MANHOLE INVERT AND THE HIGHEST PIPE INVERT IS 2'-0" OR GREATER.

MANATEE COUNTY  
PUBLIC WORKS DEPARTMENT

GRAVITY INSIDE-DROP  
FOR RETROFIT OF  
EXISTING MANHOLE

US-6

REV. BY	DATE
RTH	11/99

MARCH 18, 1997  
DATE OF APPROVAL

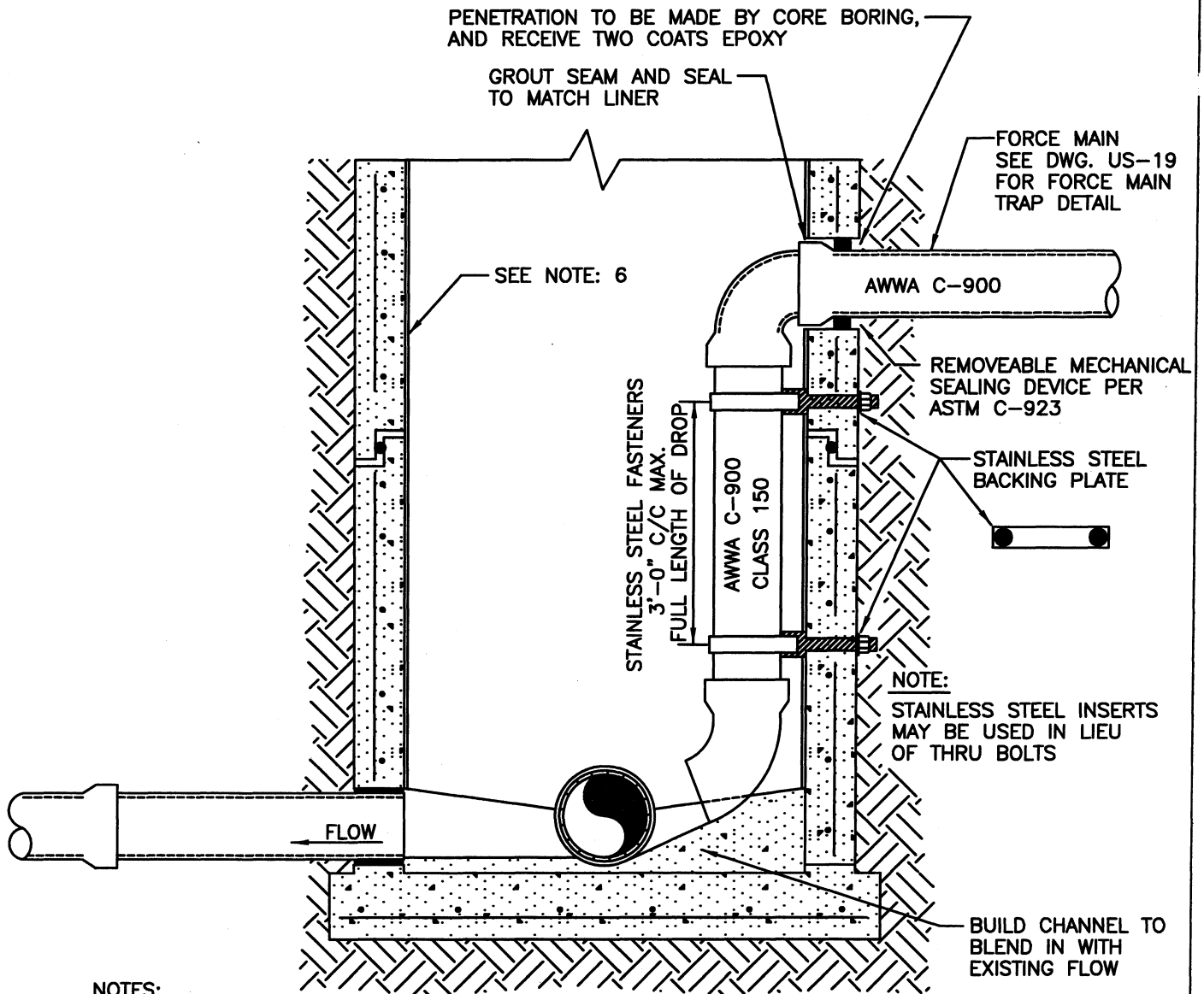

**NOTES:**

1. ALL PIPING ENTERING EXISTING STRUCTURES SHALL BE ACCOMPLISHED BY MECHANICAL ROTARY CORE BORING THE MANHOLE RISER. AFTER INSTALLATION OF PIPING, ALL PIPE OPENINGS SHALL HAVE RESILIENT PIPE TO MANHOLE SEALS AS PER ASTM C-923.
2. ALL FITTINGS SHALL BE AWWA C-907 DROP PIPE SHALL BE AWWA C-900 (CLASS 150, DR 18).
3. ALL FERROUS MATERIALS SHALL BE FULLY COATED IN AND OUT WITH 2 COATS OF KOPPERS 300-M EPOXY OR EQUAL 8 MILS DFT, TOGETHER WITH THE PENETRATION THROUGH THE STRUCTURE WALL. STAINLESS STEEL SHALL NOT BE COATED.
4. TEMPORARY BRACING FOR TESTING WILL BE REQUIRED.
5. ADAPTERS CONNECTING DIFFERENT PIPING MUST BE MANUFACTURED FOR THIS PURPOSE; SUBMIT DETAILS TO ENGINEER FOR APPROVAL.
6. THIS IS AN INTERCEPT MANHOLE AND MUST BE LINED WITH APPROVED LINER (SEE DETAIL US-3A).
7. INSIDE DROP MANHOLES ARE REQUIRED WHEN THE VERTICAL DISTANCE BETWEEN THE LOWEST EXISTING MANHOLE INVERT AND THE HIGHEST PIPE INVERT IS 2'-0" OR GREATER.

<b>MANATEE COUNTY</b> PUBLIC WORKS DEPARTMENT		<b>FORCE MAIN          RETROFIT FOR          INSIDE-DROP          CONNECTION</b>	<b>US-7</b>
REV. BY	DATE		
RTH	11/99		
<b>MARCH 18, 1997</b> DATE OF APPROVAL			

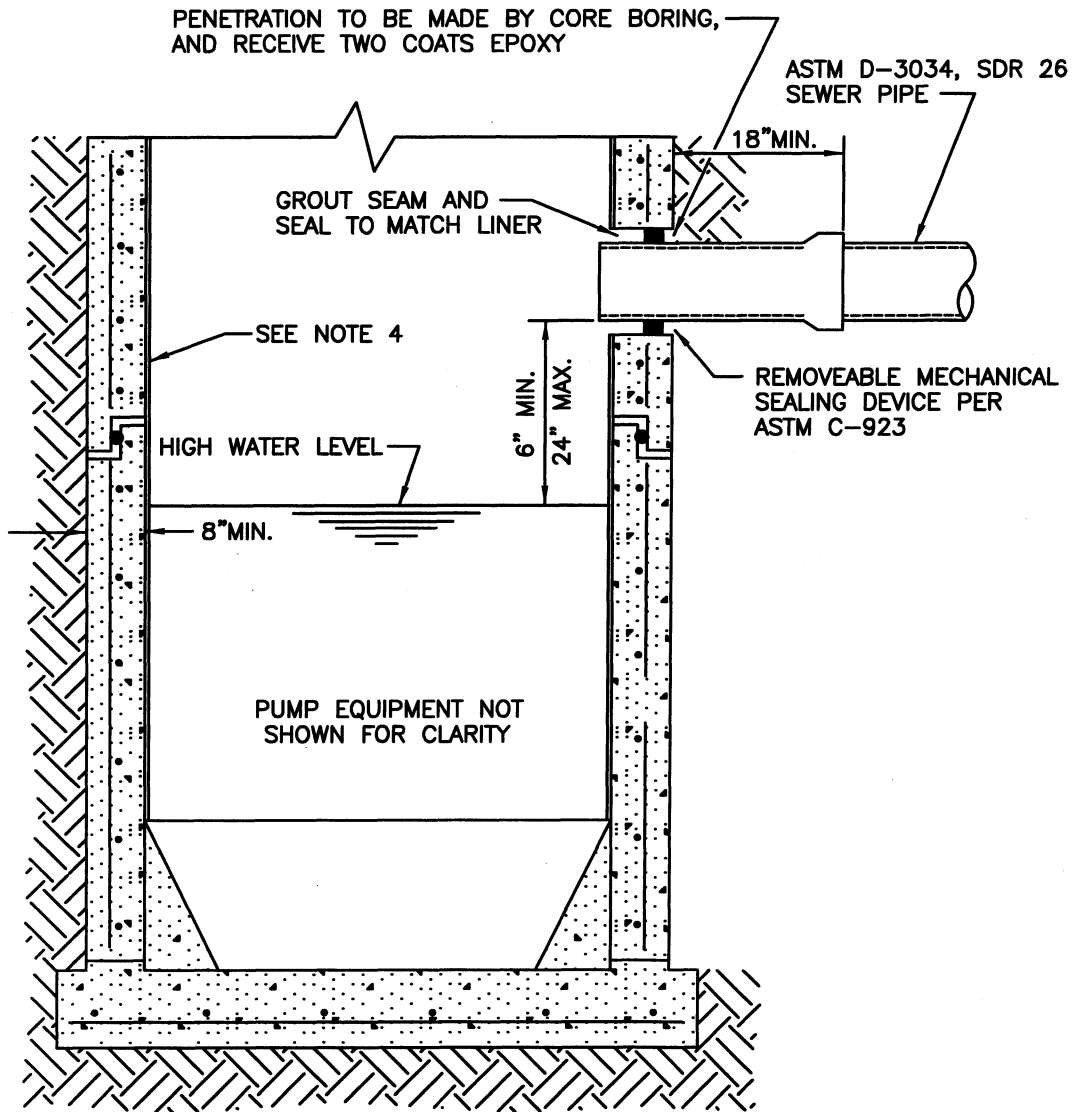

**NOTES:**

1. ALL PIPING ENTERING EXISTING STRUCTURES SHALL BE ACCOMPLISHED BY MECHANICAL ROTARY CORE BORING THE RISER. AFTER INSTALLATION OF PIPING, ALL PIPE OPENINGS SHALL HAVE RESILIENT PIPE TO MANHOLE SEALS AS PER ASTM C-923.
2. ALL METAL MATERIALS SHALL BE STAINLESS STEEL TYPE 304.
3. ADAPTERS CONNECTING DIFFERENT PIPING MUST BE MANUFACTURED FOR THIS PURPOSE; SUBMIT DETAILS TO ENGINEER FOR APPROVAL.
4. THIS STRUCTURE SHALL BE LINED WITH APPROVED LINER. (SEE DETAIL US-3A)

MANATEE COUNTY PUBLIC WORKS DEPARTMENT		GRAVITY SEWER INTO EXISTING PUMP STATION	US-8
REV. BY	DATE		
RTH	11/99	MARCH 18, 1997	
		DATE OF APPROVAL	



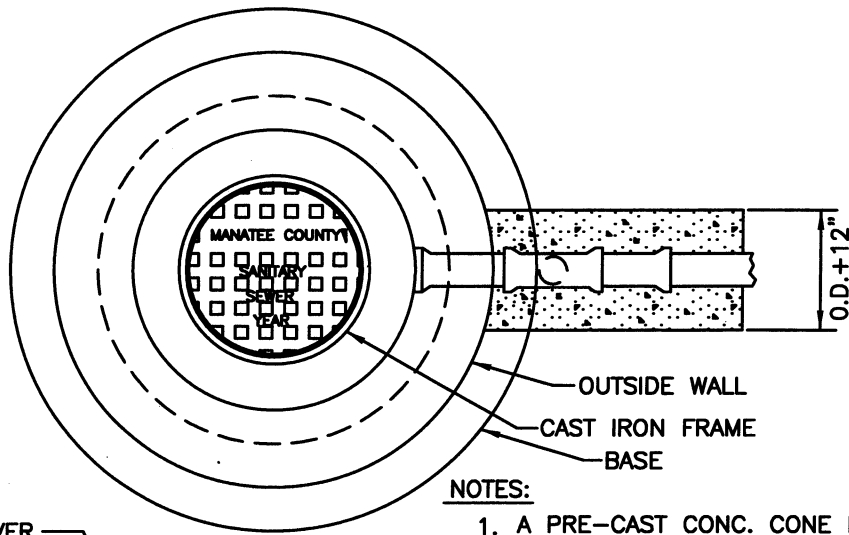

**PLAN**

STANDARD RING & COVER  
USF 170-J OR EQUAL  
MARKED "MANATEE COUNTY  
SANITARY SEWER & YEAR"  
OMIT "MANATEE COUNTY"  
IF PRIVATELY MAINTAINED.

**NOTES:**

1. A PRE-CAST CONC. CONE MAY BE USED IN LIEU OF THE FLAT TOP SHOWN IN THIS DETAIL.
2. A PRE-CAST CONC. OUTSIDE DROP MAY BE USED IN LIEU OF THE CAST IN PLACE ENCASUREMENT SHOWN BELOW.

MIN. REINFORCING  
FOR 10 1/2" SLAB:  
#4 @ 6" EACH WAY  
TOP & BOTTOM  
PLUS (4) #4  
DIAGONAL BARS  
IN BOTTOM  
w/ 2" COVER

MIN. REINFORCING  
FOR 8" SLAB:  
#5 @ 6" EACH WAY  
TOP & BOTTOM  
PLUS (4) #5  
DIAGONAL BARS  
IN BOTTOM  
w/ 2" COVER

**NOTE:**

MANHOLE WALLS SHALL BE REINFORCED WITH WELDED WIRE CONFORMING TO A.S.T.M. A-82 AND CONSTRUCTED IN ACCORDANCE WITH A.S.T.M. C-478.

PROVIDE RUBBER GASKET PER A.S.T.M. C-923, CAST INTEGRALLY IN MANHOLE WALL AND LOCATED AS REQUIRED FOR 8" SANITARY SEWER

3,000 P.S.I. CONCRETE

BEDDING

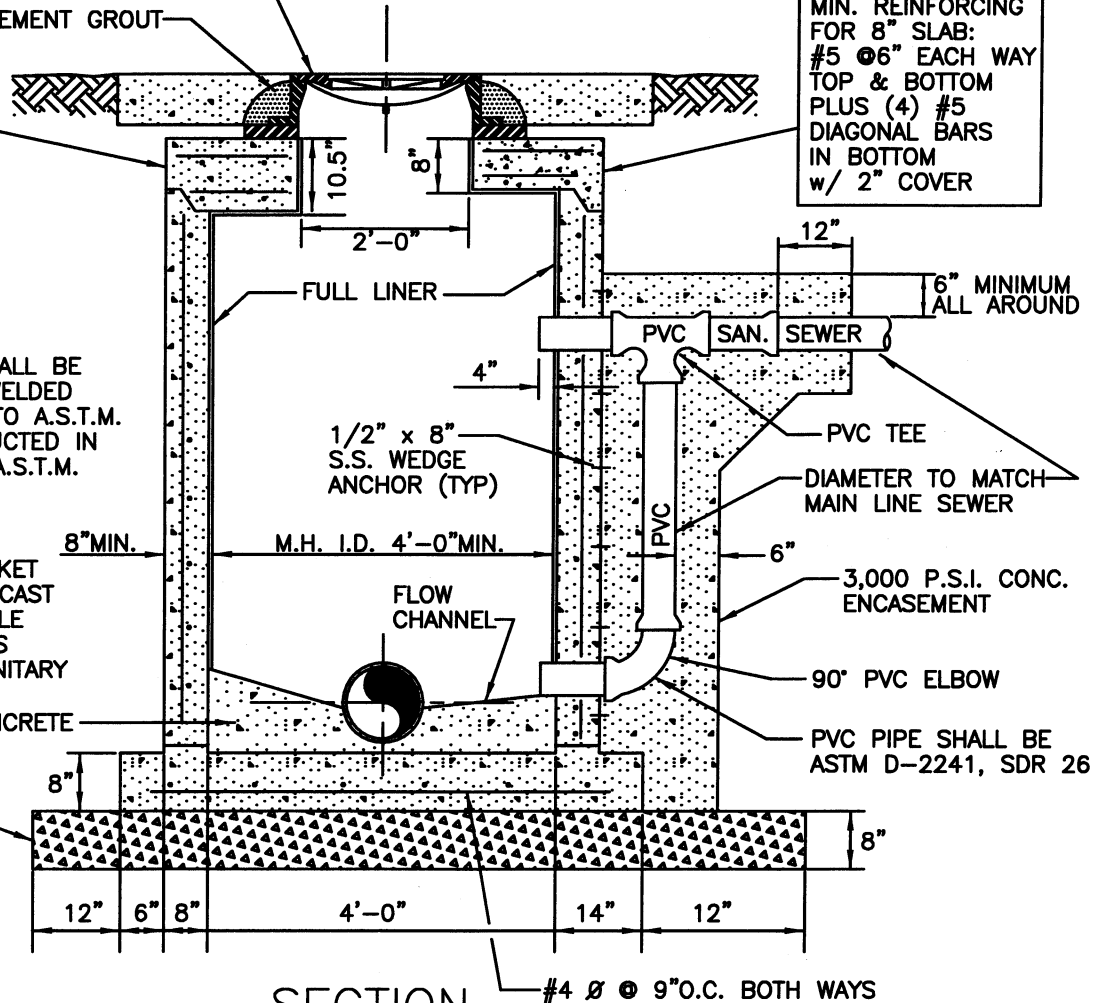

**SECTION**

**NOTE:**

1. THIS IS AN INTERCEPT MANHOLE AND MUST BE LINED WITH AN APPROVED LINER (SEE US-3A).
2. DROP MANHOLES ARE REQUIRED WHEN THE VERTICAL DISTANCE BETWEEN THE LOWEST EXISTING MANHOLE INVERT AND THE HIGHEST PIPE INVERT IS 2'-0" OR GREATER.

MANATEE COUNTY PUBLIC WORKS DEPARTMENT		MARCH 18, 1997 DATE OF APPROVAL	GRAVITY SEWER STANDARD DROP CONNECTION DETAIL	US-9
REV. BY	DATE			
RTH	11/99			





MANATEE COUNTY  
PUBLIC WORKS  
DEPARTMENT  
ENGINEERING DIVISION

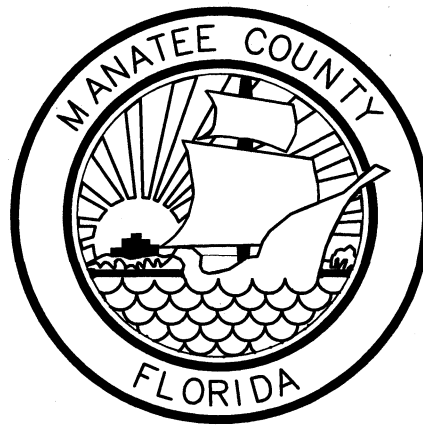

MARCH 1997  
REVISED NOVEMBER 1999

STANDARDS FOR  
WATER DISTRIBUTION  
SYSTEM

SUBSTANTIAL EFFORT HAS BEEN MADE TO ENSURE THE INFORMATION IN THESE STANDARDS IS ACCURATE HOWEVER, MANATEE COUNTY PUBLIC WORKS DEPT. CANNOT ACCEPT RESPONSIBILITY FOR ANY ERRORS OR OVERSIGHT IN THE USE OF THE MATERIAL OR IN THE PREPARATION OF THE ENGINEERING PLANS. THIS PUBLICATION IS INTENDED FOR USE BY PROFESSIONAL PERSONNEL COMPETENT TO EVALUATE THE SIGNIFICANCE AND LIMITATIONS OF THE CONTENTS AND ABLE TO ACCEPT RESPONSIBILITY FOR THE APPLICATION OF THE MATERIAL IT CONTAINS.

THE DESIGNER MUST RECOGNIZE THAT NO HANDBOOK OR CODE CAN BE A SUBSTITUTE FOR EXPERIENCED ENGINEERING JUDGEMENT.

USERS OF THESE STANDARDS ARE ENCOURAGED TO OFFER COMMENTS TO MANATEE COUNTY PUBLIC WORKS DEPARTMENT ON THE CONTENTS OF THIS PUBLICATION AND SUGGESTIONS FOR CHANGES IN THE FUTURE EDITIONS.

PRODUCTS TO BE CONSIDERED "APPROVED EQUAL" SHALL BE SUBMITTED TO THE PUBLIC WORKS DIRECTOR FOR APPROVAL.

THESE RECOMMENDATIONS ARE UNDER CONSTANT REVIEW AND ARE SUBJECT TO CHANGES APPROVED BY THE DIRECTOR OF PUBLIC WORKS.

MANATEE COUNTY PUBLIC WORKS DEPARTMENT		INTRODUCTION MANATEE COUNTY UTILITY STANDARDS	UW-1
REV. BY	DATE		
	MARCH 18, 1997		
	DATE OF APPROVAL		

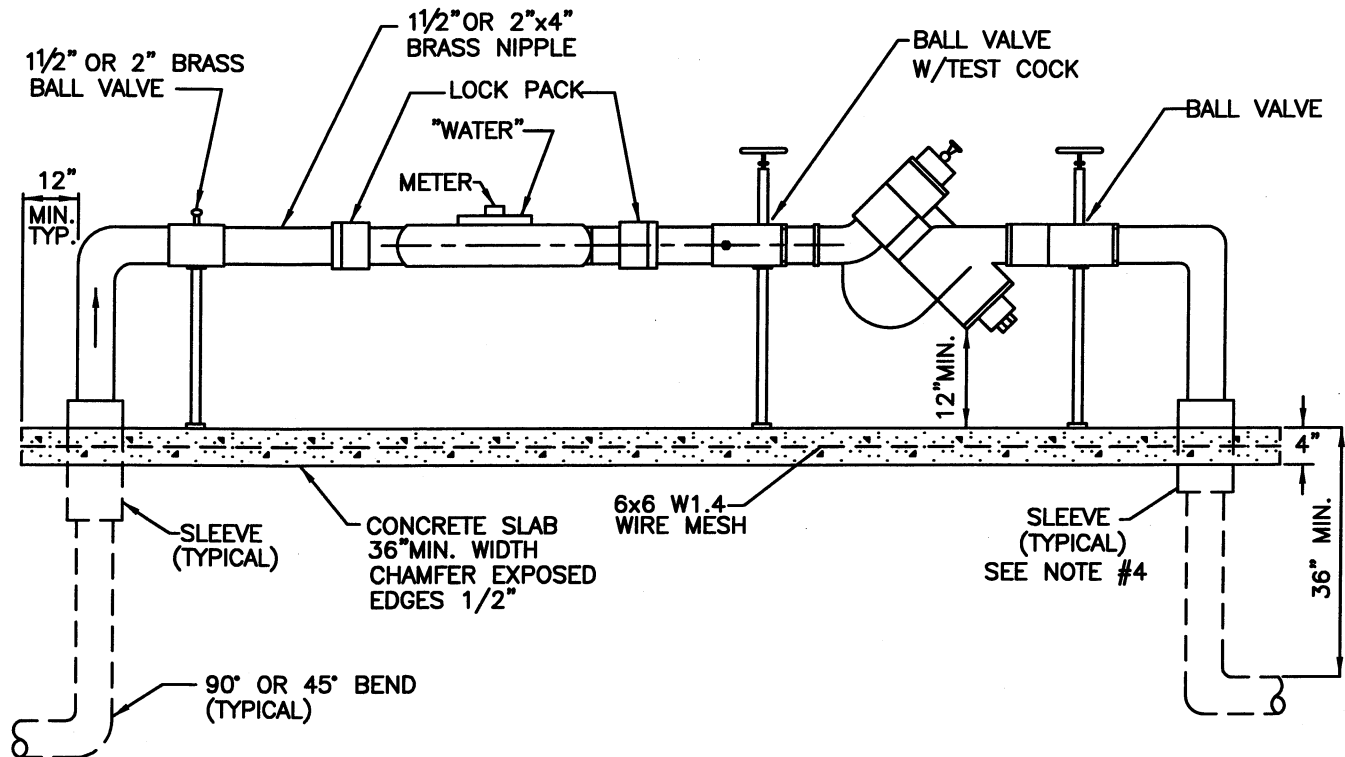

**NOTES:**

1. BOTTOM OF BACKFLOW DEVICE MUST BE 12" ABOVE FINISHED GRADE.
2. BACKFLOW DEVICE MUST BE INSTALLED DOWNSTREAM OF METER, AS CLOSE TO METER AS POSSIBLE.
3. COPPER PIPE TYPE "L" OR "K" OR BRASS PIPE MINIMUM SCHEDULE 40 SHALL BE USED TO A MINIMUM DEPTH OF 36" BELOW GRADE.
4. PIPES PASSING THROUGH OR ENCASED IN CONCRETE MUST BE PROPERLY PROTECTED AND SLEEVED.
5. THE SYSTEM MUST MEET ALL REQUIREMENTS OF THE MANATEE COUNTY PLUMBING CODE (Latest Edition) AND THE MANATEE COUNTY BACKFLOW PREVENTION CODE (Latest Edition).
6. ALL PIPING FROM BACKFLOW DEVICE TO THE FIRST ATMOSPHERIC OPENING OR TO EACH BRANCH VALVE, MUST BE COLOR CODED BLUE.
7. METER, LOCK PACKS AND BRASS NIPPLES WILL BE PROVIDED BY M.C.P.W.D.
8. FOR USE WHERE BACKFLOW PREVENTER IS REQUIRED WITH METER.

MANATEE COUNTY PUBLIC WORKS DEPARTMENT		1 1/2" & 2" METER & BACKFLOW PREVENTER DETAIL	UW-10
REV. BY RTH	DATE 11/99		
MARCH 18, 1997 DATE OF APPROVAL			

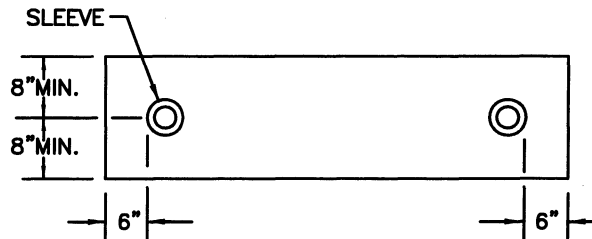
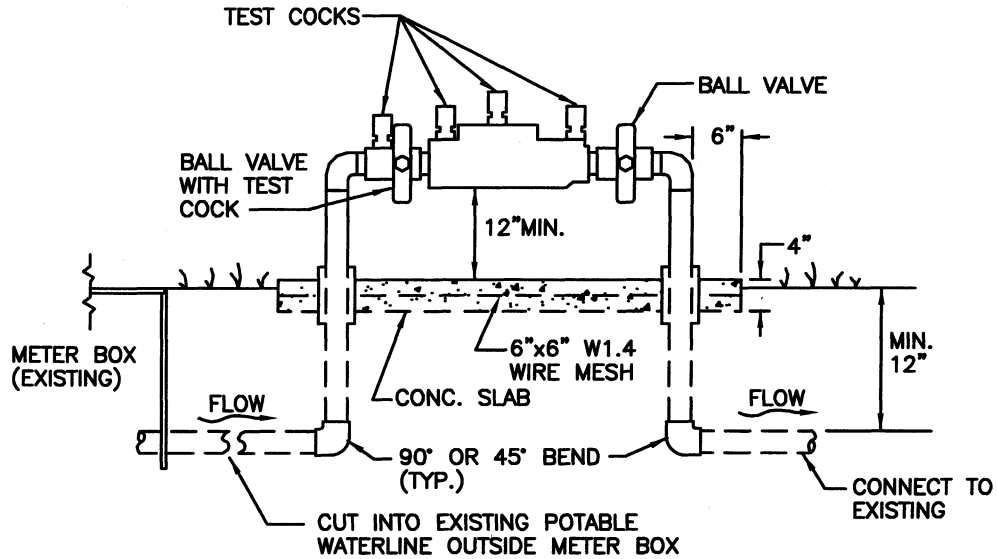

NOTES:

1. BOTTOM OF BACKFLOW DEVICE MUST BE 12" ABOVE CONCRETE PAD. CONCRETE PAD MUST BE 1" ABOVE FINISHED GRADE.
2. BACKFLOW DEVICE MUST BE INSTALLED DOWNSTREAM OF METER, AS CLOSE TO METER AS POSSIBLE.
3. COPPER PIPE TYPE "L" OR "K" OR BRASS PIPE MINIMUM SCHEDULE 40 SHALL BE USED TO A MINIMUM DEPTH OF 12" BELOW GRADE.
4. PIPES PASSING THROUGH OR ENCASED IN CONCRETE MUST BE PROPERLY PROTECTED AND SLEEVED.
5. THE SYSTEM MUST MEET ALL REQUIRMENTS OF THE MANATEE COUNTY PLUMBING CODE (LATEST EDITION) AND THE MANATEE COUNTY BACKFLOW PREVENTION CODE (LATEST EDITION).
6. ALL PIPING FROM BACKFLOW DEVICE TO THE FIRST ATMOSPHERIC OPENING OR TO EACH BRANCH VALVE, MUST BE COLOR CODED BLUE.

MANATEE COUNTY  
PUBLIC WORKS DEPARTMENT

3/4" & 1" BACKFLOW  
PREVENTER DETAIL

UW-10A

REV. BY	DATE	
		NOVEMBER 1, 1999
		DATE OF APPROVAL

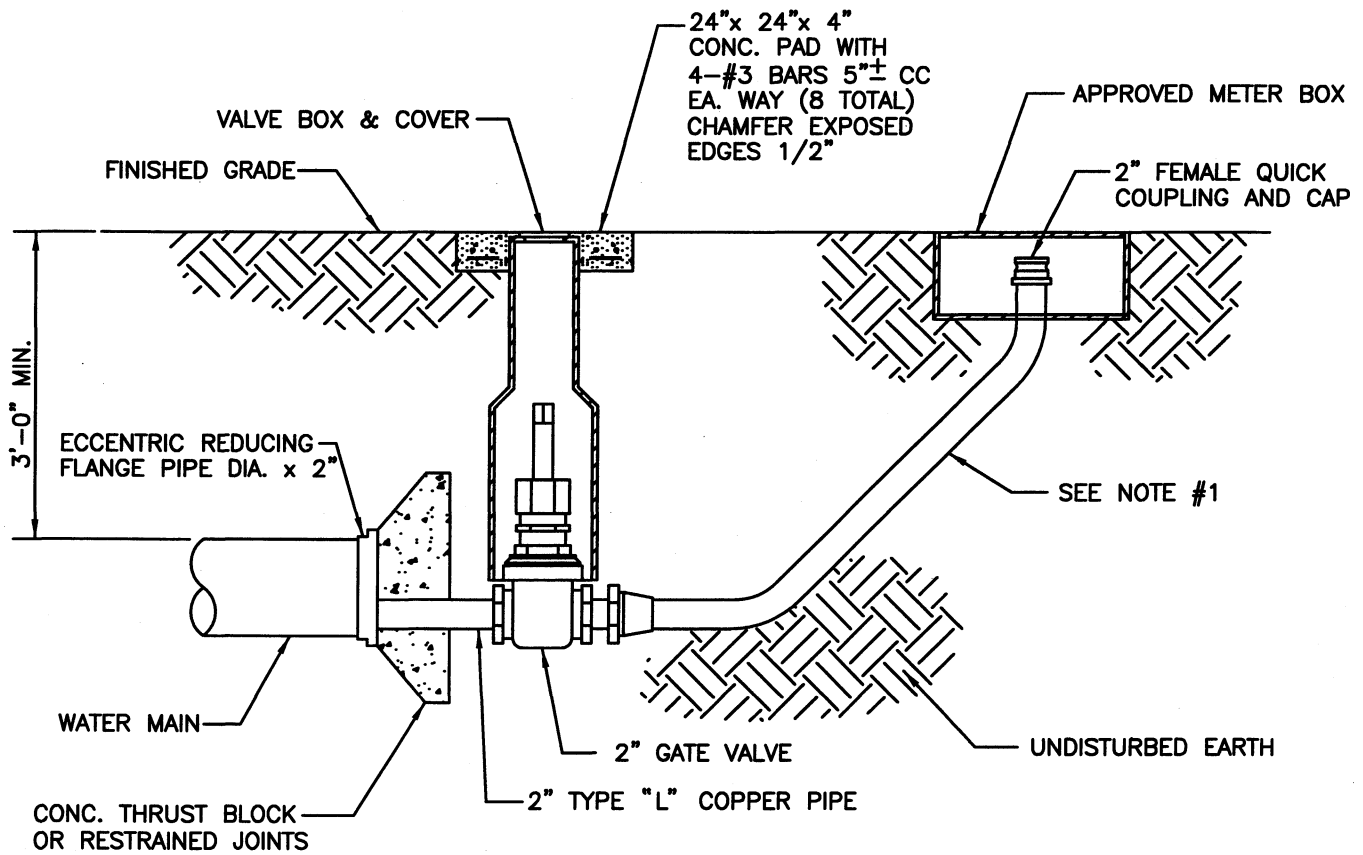

**NOTES:**

1. POLYETHYLENE SERVICE PIPE MEETING AWWA C-901, SHALL BE POLY-E DRISCOPIPE 5100 ULTRA-LINE OR ENDOPURE BY ENDOT OR APPROVED EQUAL. PIPE SHALL BE BLUE OR ENCASED IN BLUE SLEEVE.
2. IF FUTURE WATER MAIN EXTENSION BEYOND THIS PLUG IS POSSIBLE, PROVIDE A MAIN-LINE GATE VALVE BETWEEN THIS PLUG & THE LAST SERVICE BUT THE DISTANCE BETWEEN THE IN-LINE VALVE & THE PLUG SHALL NOT EXCEED 40 FEET.
3. THIS DETAIL TO BE USED FOR ALL WATER MAINS 10"DIA. OR SMALLER.

MANATEE COUNTY PUBLIC WORKS DEPARTMENT		MARCH 18, 1997 DATE OF APPROVAL	END OF LINE 2" BLOW-OFF ASSEMBLY	UW-11
REV. BY	DATE			
RTH	11/99			

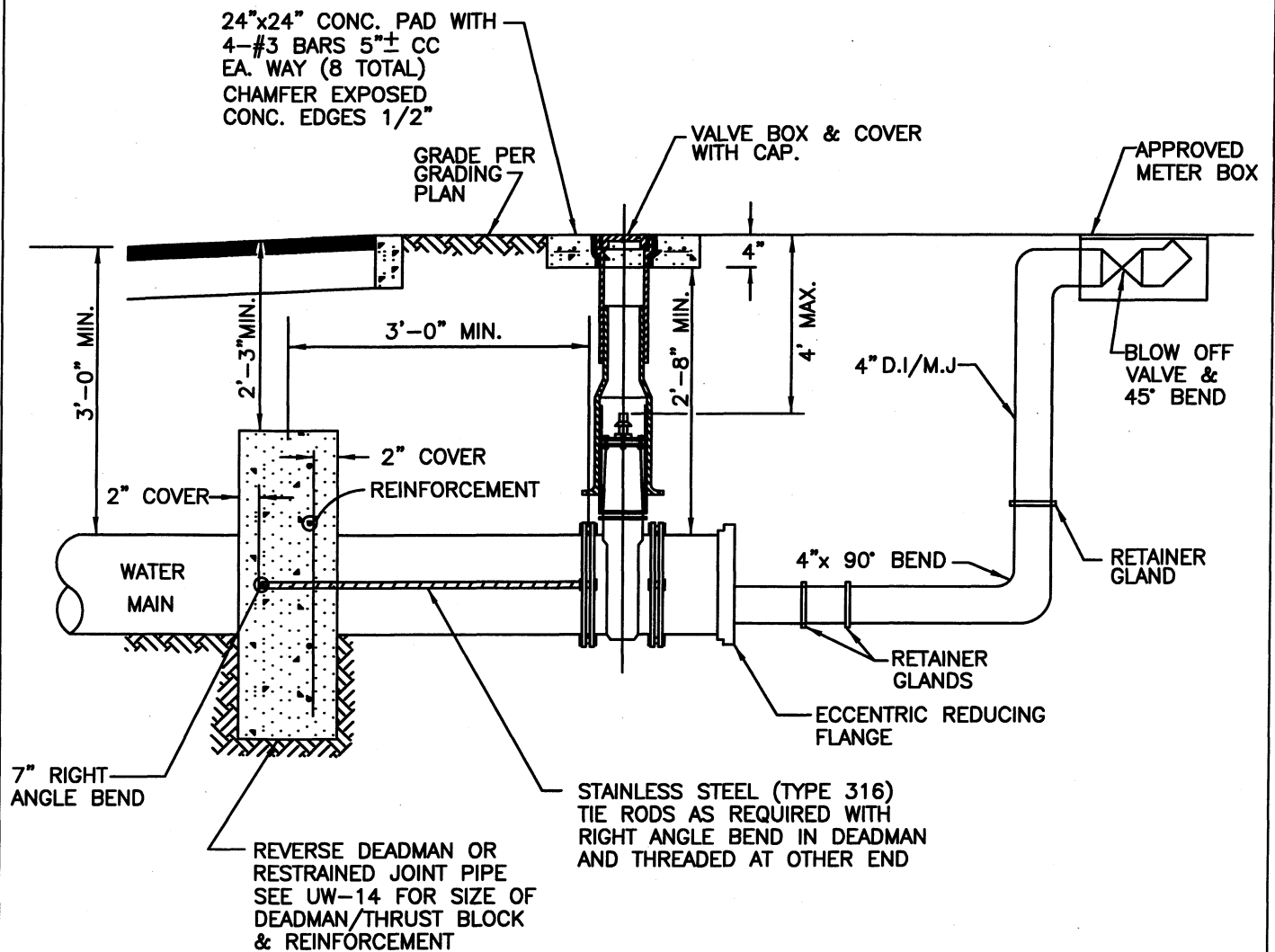

**NOTE:**

THIS DETAIL TO BE USED FOR ALL  
WATER MAINS LARGER THAN 10" DIA.

MANATEE COUNTY  
PUBLIC WORKS DEPARTMENT

REV. BY	DATE

MARCH 18, 1997  
DATE OF APPROVAL

4" AND LARGER  
BLOW-OFF ASSEMBLY

UW-12

**NOTES:**

- 1.) METER BOXES & YOKE ARE TO BE INSTALLED BY THE INFRASTRUCTURE CONTRACTOR AND SHALL NOT BE SET IN DRAINAGE SWALES, EASEMENTS OR SIDEWALKS.
- 2.) SERVICES TO BE MARKED IN CURB WITH A BLUE DISC THAT HAS THE FOOTAGE FROM THE BACK OF CURB TO THE CENTER OF THE METER BOX OR IF NO CURB, A BLUE DISC IN THE EDGE OF PAVEMENT WITH THE FOOTAGE FROM THE DISC TO THE CENTER OF THE METER BOX.

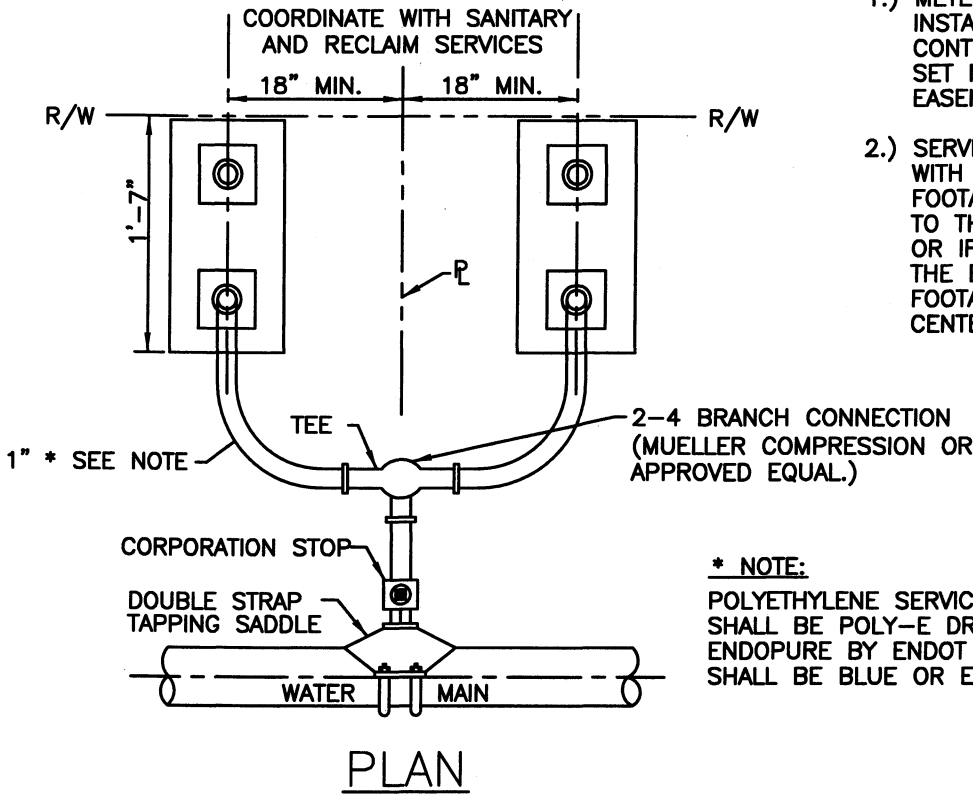

**\* NOTE:**

POLYETHYLENE SERVICE PIPE MEETING AWWA C-901, SHALL BE POLY-E DRISCOPIPE 5100 ULTRA-LINE OR ENDOPURE BY ENDOT OR APPROVED EQUAL. PIPE SHALL BE BLUE OR ENCASED IN BLUE SLEEVE.

PLAN

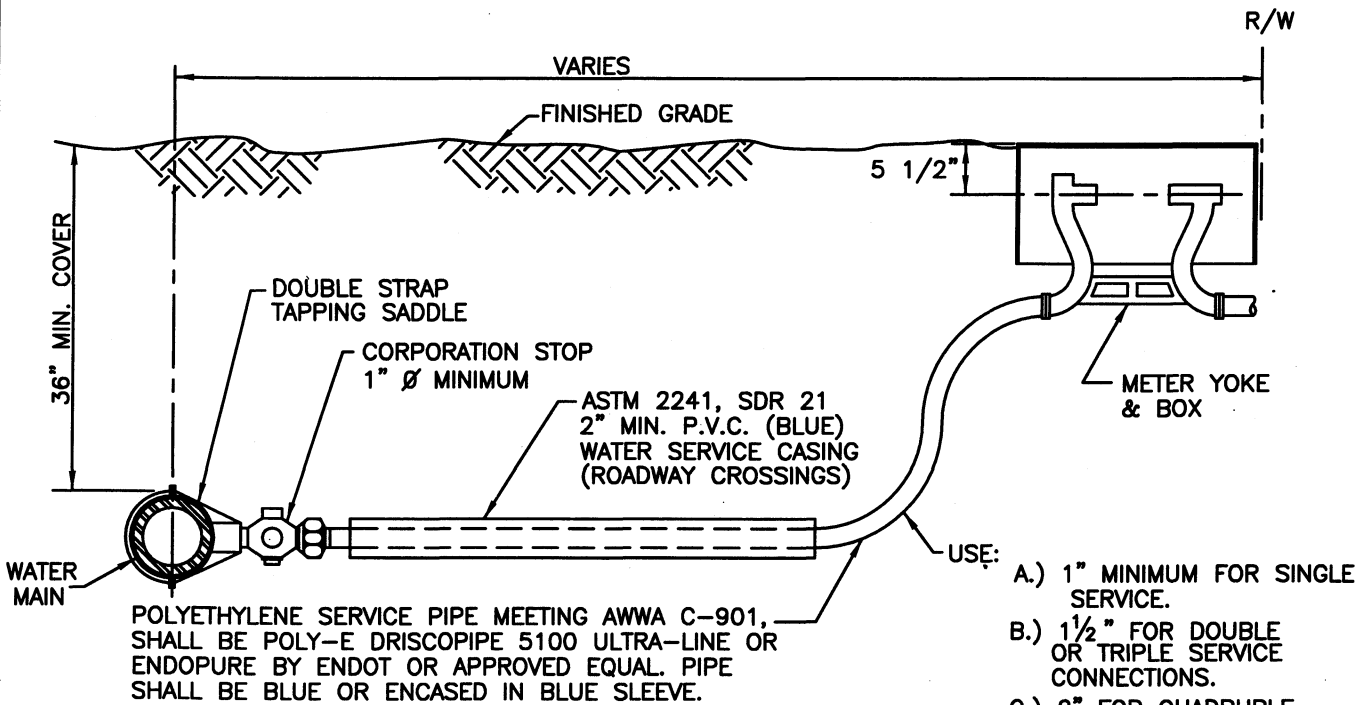

POLYETHYLENE SERVICE PIPE MEETING AWWA C-901, SHALL BE POLY-E DRISCOPIPE 5100 ULTRA-LINE OR ENDOPURE BY ENDOT OR APPROVED EQUAL. PIPE SHALL BE BLUE OR ENCASED IN BLUE SLEEVE.

- USE:
- A.) 1" MINIMUM FOR SINGLE SERVICE.
  - B.) 1 1/2" FOR DOUBLE OR TRIPLE SERVICE CONNECTIONS.
  - C.) 2" FOR QUADRUPLE SERVICE USING 3" CASING.

**NOTES:**

SECTION

1. ALL SERVICE TAPS TO BE LOCATED IN FIELD. TAPS SHALL BE NO CLOSER THAN 2'-0" STAGGERED INTERVALS OR WITHIN 2'-0" FROM BELL OR SPIGOT ENDS.
2. METER YOKE AND BOX TO BE FURNISHED AND INSTALLED BY THE INFRASTRUCTURE CONTRACTOR.

MANATEE COUNTY PUBLIC WORKS DEPARTMENT		TYPICAL WATER SERVICE CONNECTION	UW-13
REV. BY	DATE		
	MARCH 18, 1997		
	DATE OF APPROVAL		

THRUST BLOCK DIMENSIONS B ft. x d inches												
PIPE SIZE (IN.)	90° BEND		45° BEND		22.5° BEND		11.25° BEND		DEAD END & TEE		45° WYE	
	B	d	B	d	B	d	B	d	B	d	B	d
4	1.3	3 1/2	1.0	3 1/2	0.7	3 1/2	0.6	3 1/2	1.1	3 1/2	1.0	3 1/2
6	1.9	4 1/2	1.5	3 3/4	1.1	3 1/2	0.8	3 1/2	1.6	4	1.5	3 3/4
8	2.6	6 1/4	1.9	4 3/4	1.4	3 1/2	1.0	3 1/2	2.2	5 1/2	1.8	4 1/2
10	3.2	7 3/4	2.4	6	1.7	4 1/4	1.2	3 1/2	2.7	6 1/2	2.3	5 1/2
12	3.8	9 1/4	2.8	6 3/4	2.0	5	1.5	3 3/4	3.2	7 3/4	2.7	6 1/2
14	4.5	11	3.3	8	2.4	6	1.7	4 1/4	3.8	9 1/4	3.2	7 3/4
16	5.1	12 1/4	3.8	9 1/4	2.7	6 1/2	1.9	4 3/4	4.3	10 1/2	3.6	8 3/4
18	5.7	13 3/4	4.2	10 1/4	3.0	7 1/4	2.2	5 1/2	4.8	11 3/4	4.1	10
20	6.4	15 1/2	4.7	11 1/2	3.4	8 1/4	2.4	6	5.4	13	4.5	11
24	7.6	18 1/4	5.6	13 1/2	4.0	9 3/4	2.9	7	6.4	15 1/2	5.4	13
30	9.5	23	7.0	17	5.0	12	3.6	8 3/4	8.0	19 1/4	6.7	16
36	11.4	27 1/2	8.4	20 1/4	6.0	14 1/2	4.3	10 1/2	9.6	23	8.1	19 1/2

	REINFORCEMENT MAT SCHEDULE
	FOR DIM. "B" BETWEEN 5.75' & 11.5' USE #4 @ 8" EACH WAY FOR DIM. "B" LESS THAN 5.75' USE #3 @ 8" EACH WAY

**NOTES:**

1. THIS TABLE IS BASED ON WATER PRESSURE=180 PSI WITH AN ALLOWABLE SOIL BEARING PRESSURE=2000 PSF, CONCRETE STRENGTH  $f_c=3000$  PSI, REINFORCEMENT  $f_y=60.0$  KSI THRUST BLOCK CAST AGAINST FIRM UNDISTURBED OR COMPACTED SOIL.
2. FOR LARGER "B" DIMENSIONS IT IS NECESSARY TO CHECK THAT PIPE IS SUFFICIENTLY DEEP TO ALLOW 15" MIN. SOIL COVER OVER TOP EDGE OF THRUST BLOCK.

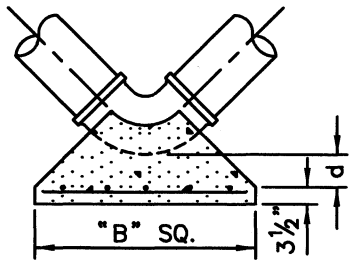

90° BEND

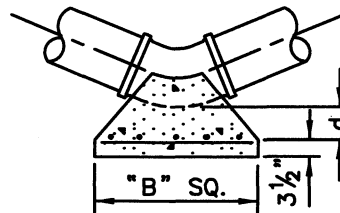

45°, 22.5° OR 11.25° BEND

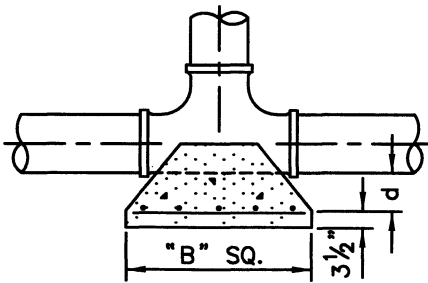

TEE OR DEAD END

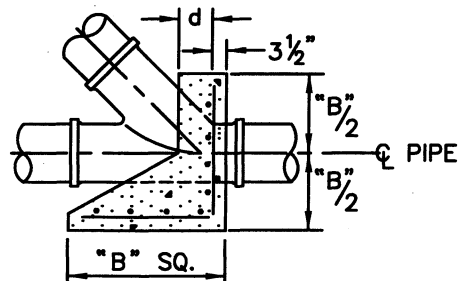

45° WYE

MANATEE COUNTY  
PUBLIC WORKS DEPARTMENT

REV. BY	DATE

MARCH 18, 1997  
DATE OF APPROVAL

THRUST BLOCK  
DETAILS

UW-14



## REQUIRED LENGTH OF RESTRAINED JOINT PIPE FOR DR-18 PVC PIPE

MAIN PIPE SIZE	HORIZ. BENDS			TEES					REDUCERS			PLUGS
	90°	45°	22.5°	SIZE					SIZE			
				LENGTH					LENGTH			
24	90	38	18	X24 177	X20 139	X16 94	X12 40	X10 6	X20 64	X16 117	X12 158	214
20	78	32	15	X20 148	X16 105	X12 56	X10 25	X8 0	X16 65	X12 115	X10 149	184
16	66	27	13	X16 116	X12 70	X10 42	X8 12		X12 64	X10 90	X8 111	151
12	51	22	10	X12 83	X10 59	X8 32	X6 0		X10 34	X8 62	X6 86	118
10	44	18	9	X10 66	X8 41	X6 8			X8 33	X6 61	X4 81	100
8	37	15	7	X8 50	X6 21	X4 0			X6 35	X4 59		83
6	29	12	5	X6 30	X4 0				X4 32			63
4	21	8	4	X4 14								45

**NOTES:**

- 1.) RESTRAIN TO NEXT FULL JOINT BEYOND GIVEN LENGTH.
- 2.) RESTRAIN 11.25° BENDS 50% OF LENGTH FOR 22.5° BENDS.
- 3.) ALL VALVES AND FITTINGS SHALL BE RESTRAINED TO THE CONNECTING SECTIONS OF PIPE.
- 4.) ALL VALVES MUST BE PROPERLY ANCHORED OR RESTRAINED TO RESIST A 180 PSI TEST PRESSURE IN EITHER DIRECTION.
- 5.) PIPE SIZES ARE GIVEN IN INCHES.
- 6.) PIPE LENGTHS ARE GIVEN IN FEET.
- 7.) LENGTHS SHOWN ARE FOR A TEST PRESURE OF 180 PSI.
- 8.) THE RESTRAINED LENGTHS SHOWN IN THESE TABLES ARE BASED ON THE USE OF LIGHTLY COMPACTED CLEAN SAND WITH AT LEAST A 95% COARSE PARTICLE CONTENT. ACTUAL SOIL CONDITIONS MUST BE DETERMINED BY THE ENGINEER OF RECORD AND THE RESTRAINED LENGTHS MODIFIED ACCORDINGLY.

MANATEE COUNTY PUBLIC WORKS DEPARTMENT		RESTRAINED LENGTHS FOR PVC PIPE	UW-14A
REV. BY	DATE		
		DATE OF APPROVAL	

## REQUIRED LENGTH OF RESTRAINED JOINT PIPE FOR DIP (POLY-WRAPPED)

MAIN PIPE SIZE	HORIZ. BENDS			TEES						REDUCERS				PLUGS
	90°	45°	22.5°	SIZE						SIZE				
				LENGTH			LENGTH			LENGTH		LENGTH		
36	116	48	23	x36 282	x30 232	x24 175	x20 130	x16 77	x12 11	X30 96	X24 173	X20 216	X16 257	317
30	102	42	20	X30 241	X24 186	X20 144	X16 95	X12 35	x10 0	X24 96	X20 150	X16 194		275
24	87	36	17	X24 197	X20 157	X16 112	X12 58	X10 25	x8 0	X20 69	X16 125	X12 170		230
20	75	31	15	X20 165	X16 122	X12 72	X10 41	x8 6		X16 69	X12 123	X10 145		197
16	63	26	13	X16 132	X12 85	X10 57	X8 25	x6 0		X12 69	X10 97	X8 119		163
12	50	21	10	X12 97	X10 71	X8 43	x6 7			X10 37	X8 68	X6 93		128
10	43	18	9	X10 78	X8 52	x6 19				X8 37	X6 67	X4 89		109
8	36	15	7	X8 60	X6 29	x4 0				X6 38	X4 65			90
6	28	12	6	X6 40	x4 5					X4 36				70
4	20	8	4	x4 19										49

## REQUIRED LENGTH OF RESTRAINED JOINT PIPE FOR DIP (NON-WRAPPED)

MAIN PIPE SIZE	HORIZ. BENDS			TEES						REDUCERS				PLUGS
	90°	45°	22.5°	SIZE						SIZE				
				LENGTH			LENGTH			LENGTH		LENGTH		
36	100	42	20	x36 198	x30 162	x24 123	x20 91	x16 54	x12 7	X30 67	X24 121	X20 151	X16 176	222
30	88	37	18	X30 169	X24 131	X20 101	X16 67	X12 25	x10 0	X24 67	X20 105	X16 136		192
24	75	31	15	X24 138	X20 110	X16 78	X12 40	X10 17	x8 0	X20 48	X16 88	X12 119		161
20	65	27	13	X20 115	X16 86	X12 50	X10 29	x8 4		X16 48	X12 86	X10 101		138
16	54	22	11	X16 92	X12 59	X10 40	x8 18	x6 0		X12 49	X10 68	X8 83		114
12	43	18	8	X12 68	X10 50	X8 30	x6 5			X10 26	X8 47	X6 65		89
10	37	15	7	X10 55	X8 36	x6 13				X8 26	X6 47	X4 62		76
8	30	13	6	X8 42	X6 20	x4 0				X6 26	X4 45			63
6	24	10	5	X6 28	x4 4					X4 25				49
4	17	7	3	x4 14										34

**NOTE:**

SEE DETAIL UW-14A FOR NOTES 1 THRU 8

MANATEE COUNTY PUBLIC WORKS DEPARTMENT		RESTRAINED LENGTHS FOR DIP	UW-14B
REV. BY	DATE		
NOVEMBER 1, 1999 DATE OF APPROVAL			

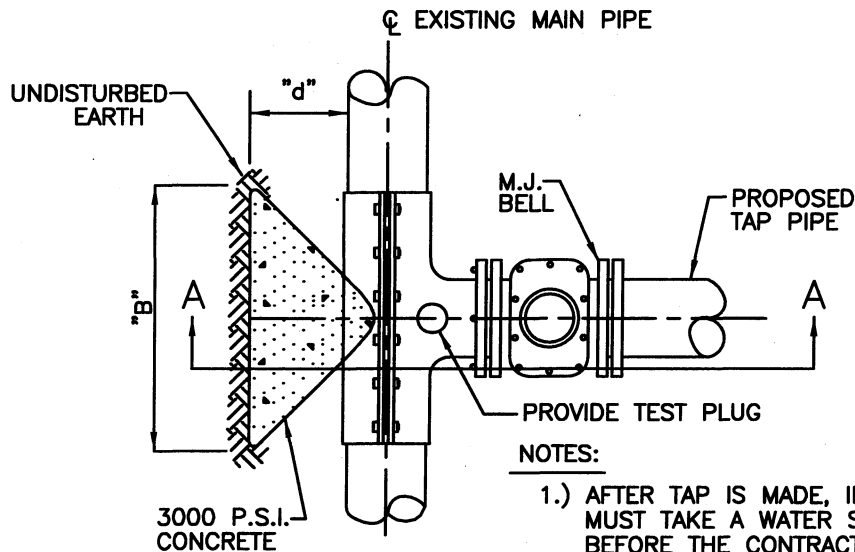

PLAN

NOTES:

- 1.) AFTER TAP IS MADE, INDUSTRIAL COMPLIANCE MUST TAKE A WATER SAMPLE AND TEST IT BEFORE THE CONTRACTOR CAN CONNECT TO M.C.P.W.D. LINE.
- 2.) CONTRACTOR TO SUPPLY A DRY HOLE FOR TAPPING CREW TO WORK AND A BACK-HOE TO LOWER MACHINE INTO HOLE.

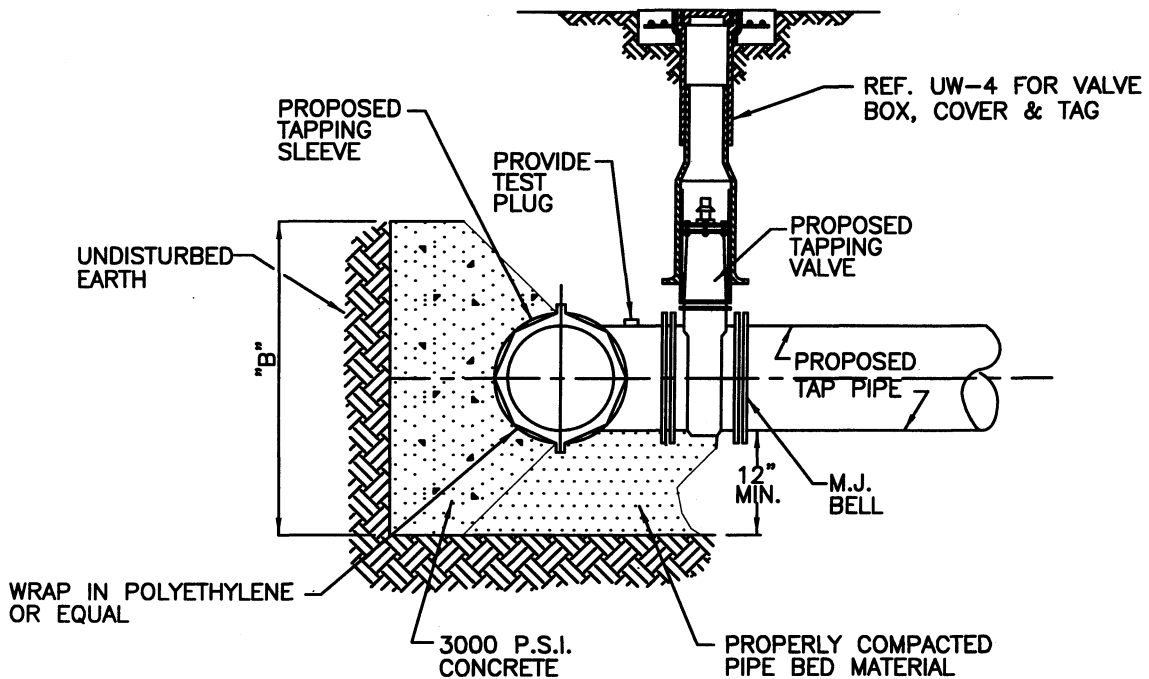

SECTION A-A

SEE UW-14 FOR DIMENSIONS "B" & "d"

NOTES:

- 1.) NO CUTS SHALL BE MADE BEFORE:
  - (A) A TEST OF 180 P.S.I. FOR 60 MINUTES IS MADE.
  - (B) ALL FITTINGS TO BE WRAPPED WITH 20 MIL VISQUEEN AT THRUST BLOCK.
  - (C) ALL TAPS TO BE MADE BY M.C.P.W.D. AND MATERIAL TO BE FURNISHED BY THE INFRASTRUCTURE CONTRACTOR.
- 2.) ALL TAPS MUST BE OF A SMALLER SIZE THAN THE MAIN BEING TAPPED & PLACED NO CLOSER THAN 30" OR A DISTANCE EQUAL TO (1) MAIN PIPE DIAMETER PLUS (2) TAP PIPE DIAMETERS (WHICHEVER IS LARGER) FROM A JOINT OR FITTING.

MANATEE COUNTY  
PUBLIC WORKS DEPARTMENT

TAPPING SLEEVE &  
VALVE BLOCKING DETAIL

UW-15

REV. BY	DATE
RTH	11/99

MARCH 18, 1997  
DATE OF APPROVAL

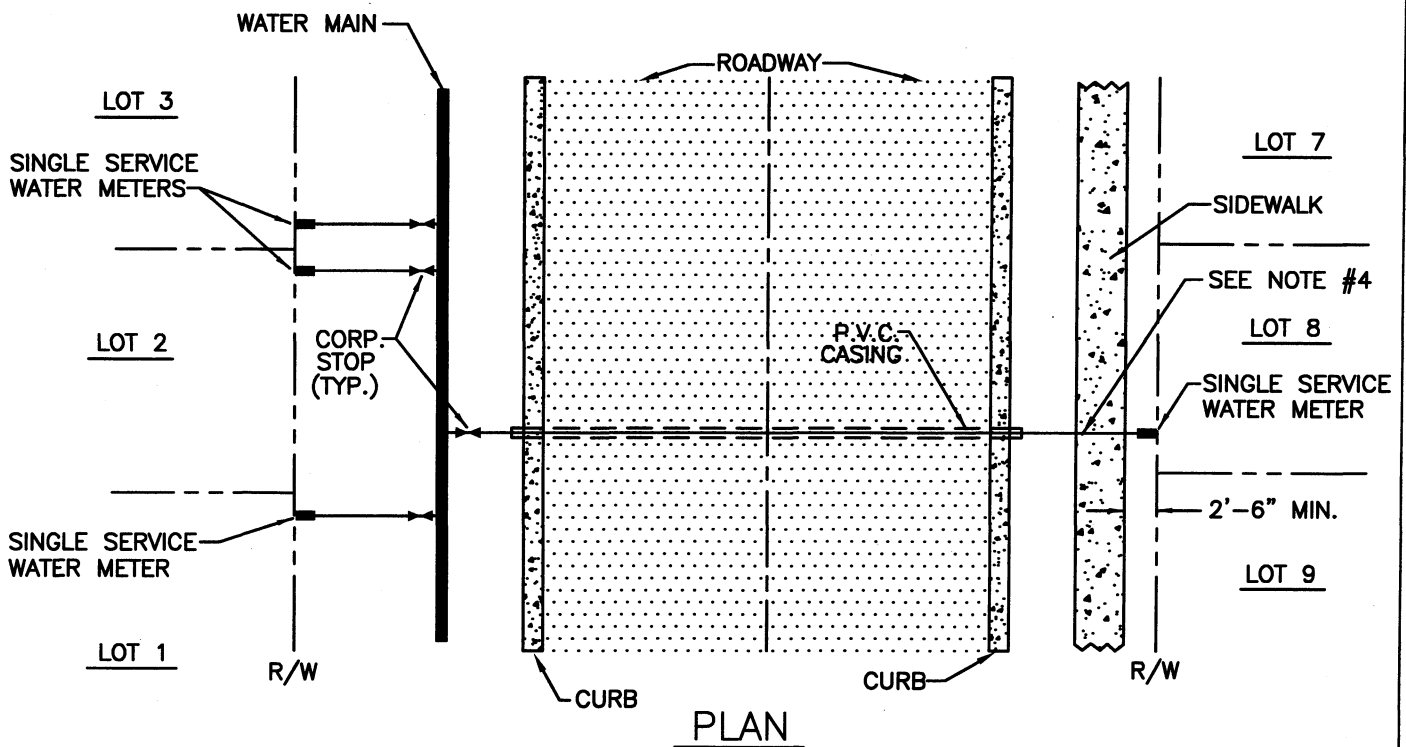
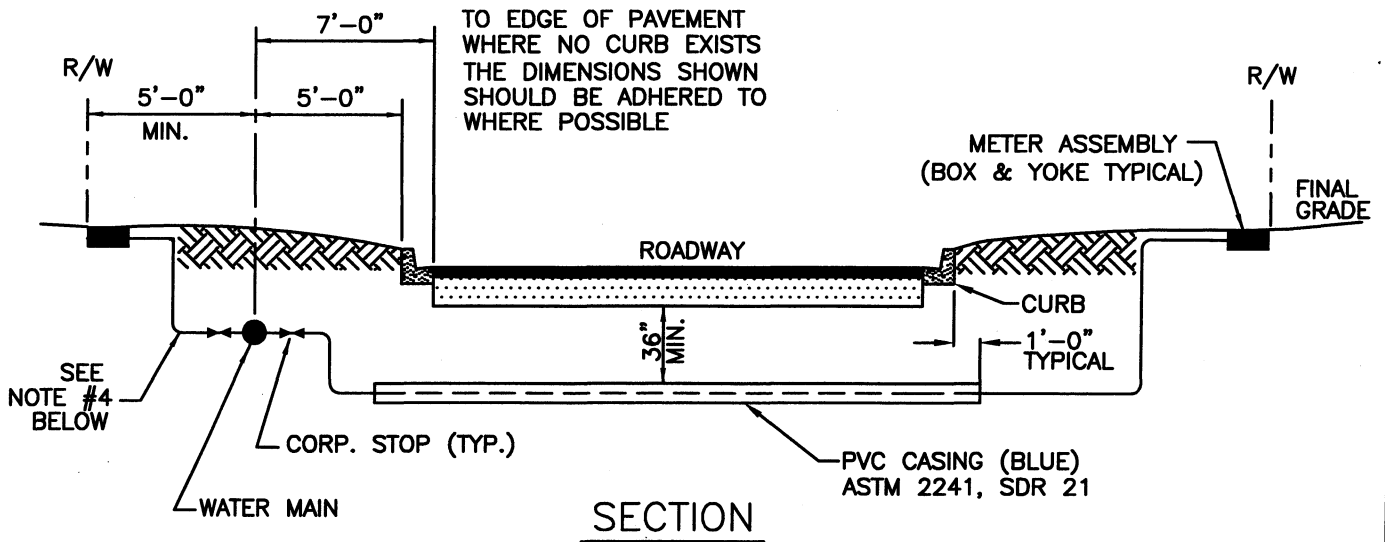

- NOTES:**
1. WATER METER SERVICE SHALL BE LOCATED TO AVOID CONFLICT WITH FPL TRANSFORMER LOCATIONS.
  2. FPL ELECTRICAL CONDUCTOR AND TRANSFORMER MAY BE ON EITHER SIDE OF THE ROADWAY.
  3. ALL METER BOX & YOKE ASSEMBLIES TO BE INSTALLED BY THE INFRASTRUCTURE CONTRACTOR.
  4. POLYETHYLENE SERVICE PIPE MEETING AWWA C-901 SHALL BE POLY-DRISCOPIPE 5100 ULTRA-LINE OR ENDOPURE BY ENDOT OR APPROVED EQUAL. PIPE SHALL BE BLUE OR ENCASED IN BLUE SLEEVE.
  5. EXACT METER LOCATIONS SHALL BE COORDINATED WITH OTHER UTILITY SERVICES.
  6. WHERE POSSIBLE WATER MAINS SHALL BE LOCATED ON THE SOUTHERLY AND EASTERLY SIDE OF ROADS AND ON THE OPPOSITE SIDE OF ROAD FROM SIDEWALK.

MANATEE COUNTY  
PUBLIC WORKS DEPARTMENT

REV. BY	DATE
RTH	11/99

MARCH 18, 1997  
DATE OF APPROVAL

SINGLE  
WATER SERVICE

UW-16

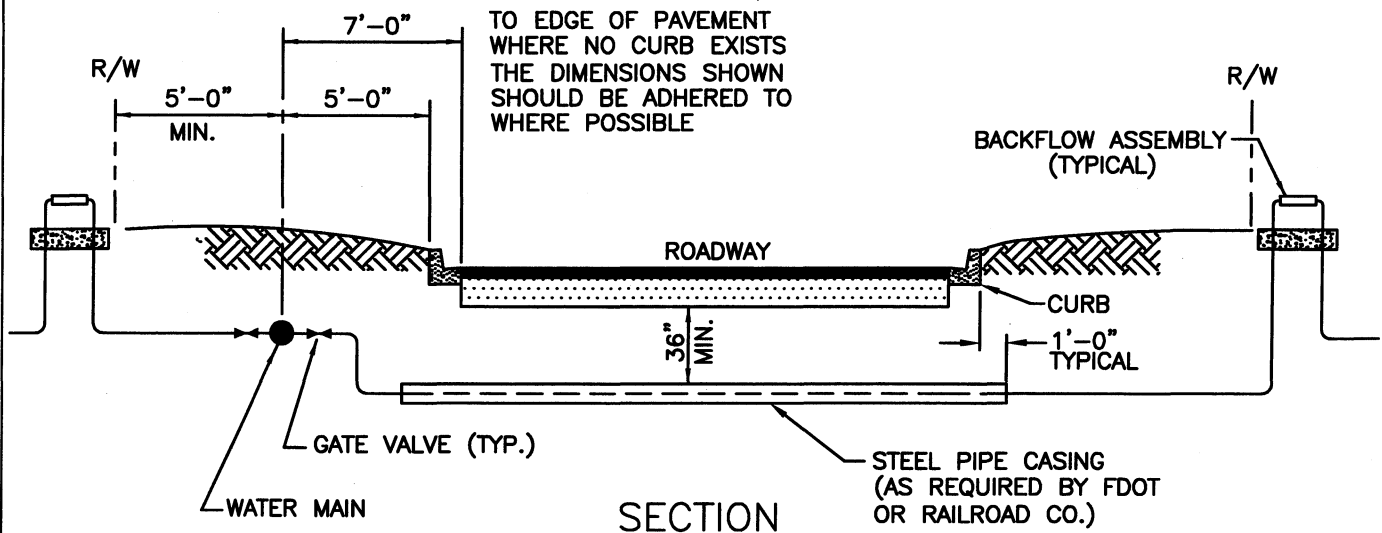

SECTION

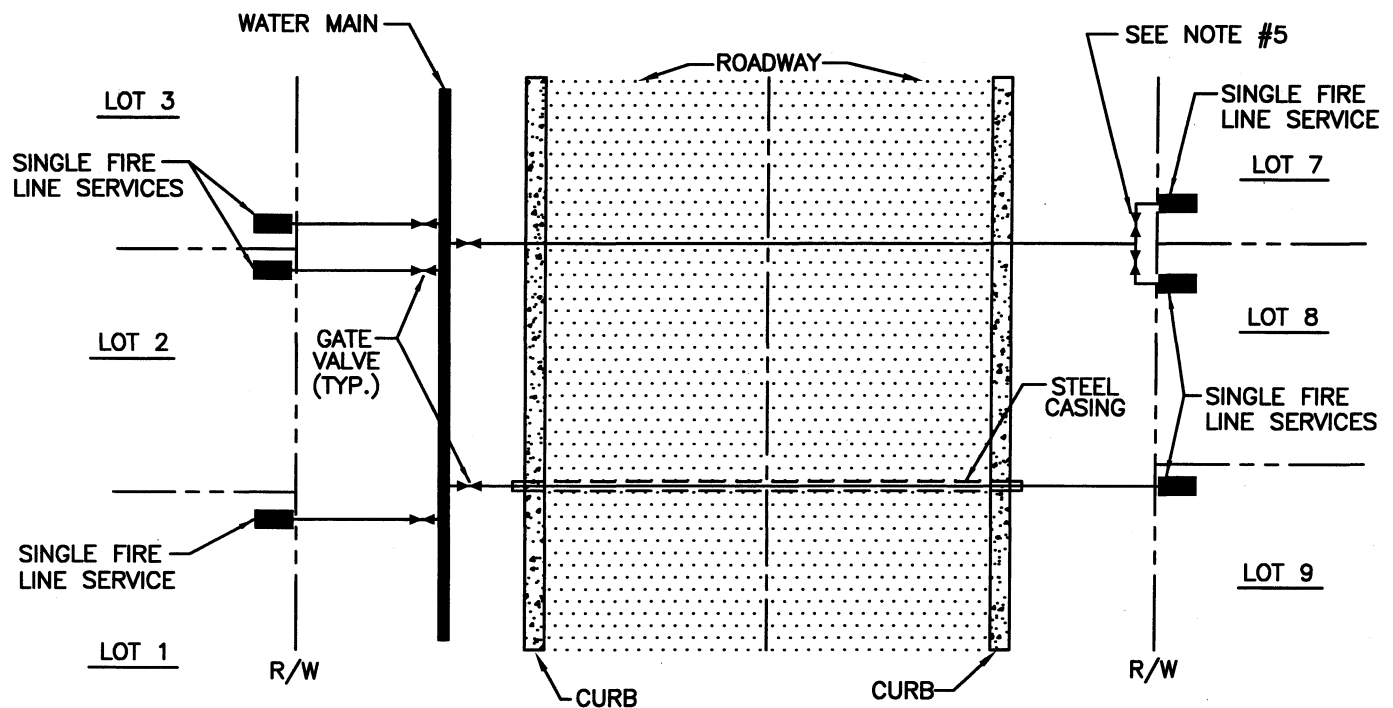

PLAN

NOTES:

1. FIRE LINE SERVICE SHALL BE LOCATED TO AVOID CONFLICT WITH FPL TRANSFORMER LOCATIONS.
2. FPL ELECTRICAL CONDUCTOR AND TRANSFORMER MAY BE ON EITHER SIDE OF THE ROADWAY.
3. EXACT BACKFLOW ASSEMBLY LOCATIONS SHALL BE COORDINATED WITH OTHER UTILITY SERVICES.
4. WHERE POSSIBLE WATER MAINS SHALL BE LOCATED ON THE SOUTHERLY AND EASTERLY SIDE OF ROADS AND ON THE OPPOSITE SIDE OF ROAD FROM SIDEWALK.
5. IF SINGLE FIRE LINE IS TO SERVE TWO LOTS THERE MUST BE A VALVE ON EACH END OF TEE.

<b>MANATEE COUNTY</b> PUBLIC WORKS DEPARTMENT		SINGLE FIRE LINE SERVICE	UW-16A
REV. BY	DATE		
	NOVEMBER 1, 1999 DATE OF APPROVAL		

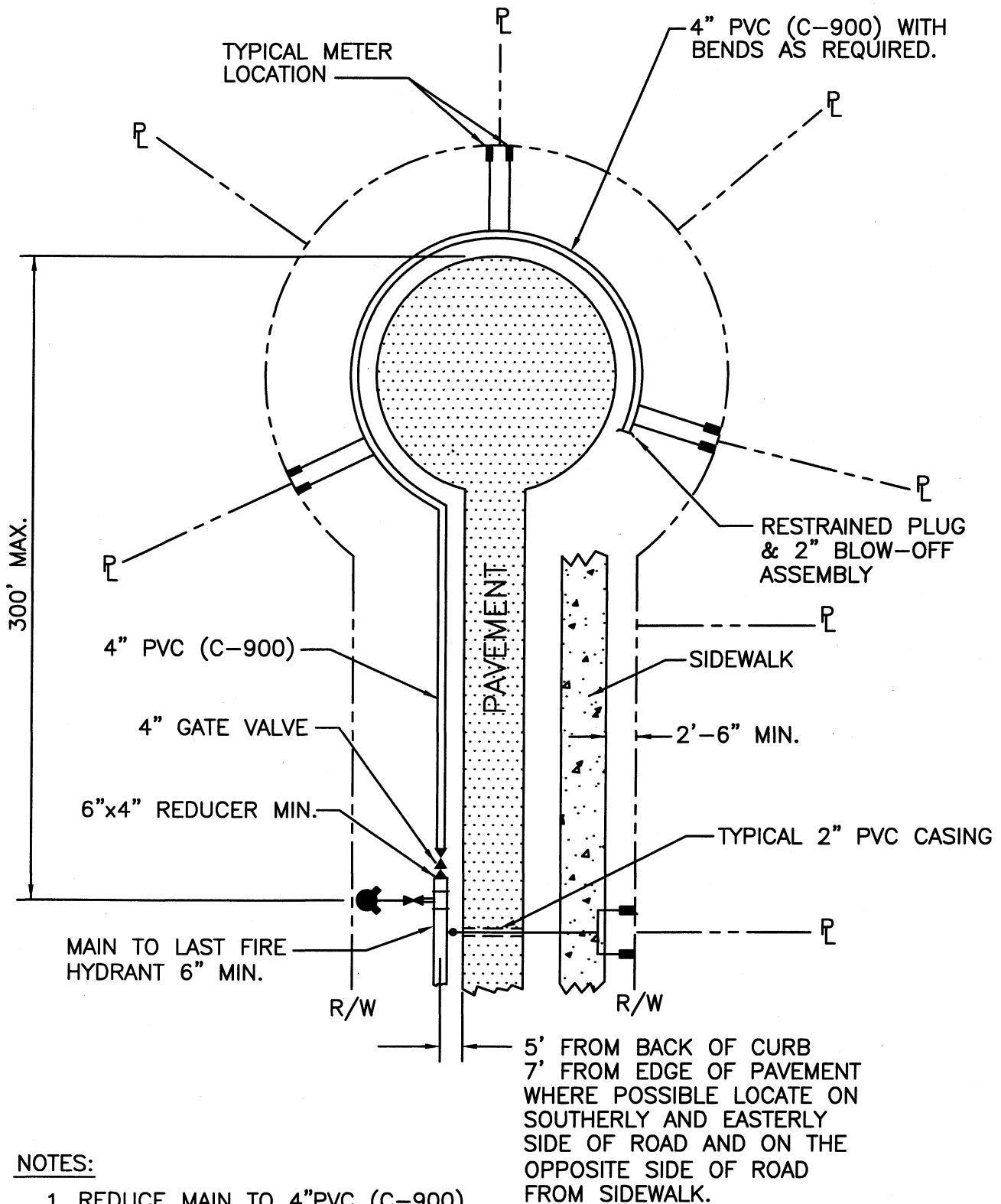

**NOTES:**

1. REDUCE MAIN TO 4" PVC (C-900) FOR PERMANENT CUL-DE-SAC CONNECTIONS ONLY. FITTINGS AS REQUIRED.
2. 5'-0" MIN. SEPARATION BETWEEN POTABLE WATER AND RECLAIMED WATER AND 10'-0" MIN. BETWEEN POTABLE WATER AND WASTE WATER SHALL BE MAINTAINED.

MANATEE COUNTY  
PUBLIC WORKS DEPARTMENT

CUL-DE-SAC DETAIL

UW-17

REV. BY	DATE
RTH	11/99

MARCH 18, 1997  
DATE OF APPROVAL

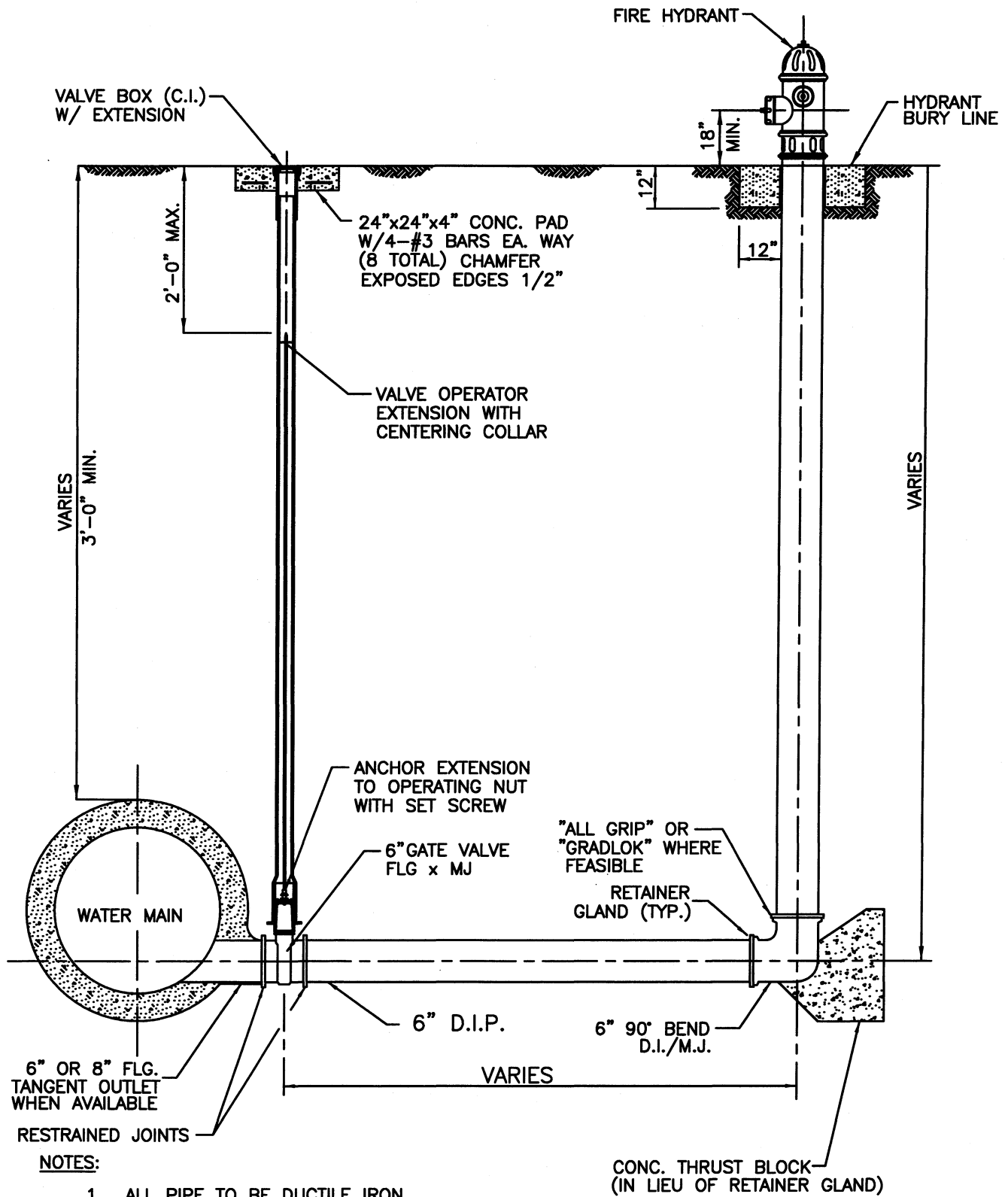

**NOTES:**

1. ALL PIPE TO BE DUCTILE IRON, CLASS 50 (MIN).
2. ALL BOLTED FITTINGS SHALL BE WRAPPED WITH POLYETHYLENE.
3. ALL CONC. TO BE A MIN. OF 2500 P.S.I.

THIS DETAIL NEEDED ONLY ON MAINS 20" AND ABOVE, REF. UW-5 FOR ALL OTHER.

<b>MANATEE COUNTY</b> PUBLIC WORKS DEPARTMENT		<b>FIRE HYDRANT          BLOW-OFF ASSY.</b>	<b>UW-18</b>
REV. BY RTH	DATE 11/99		

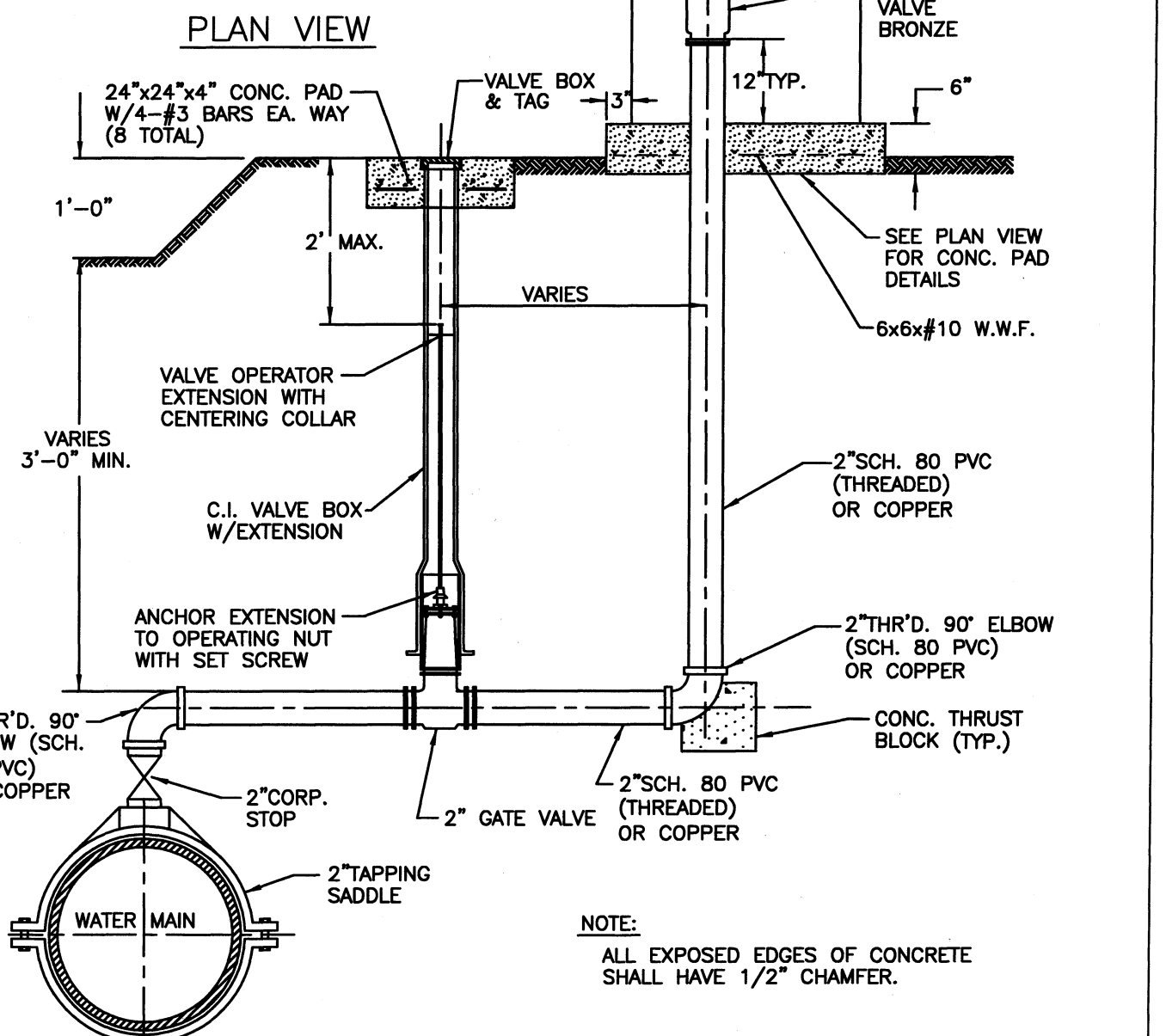
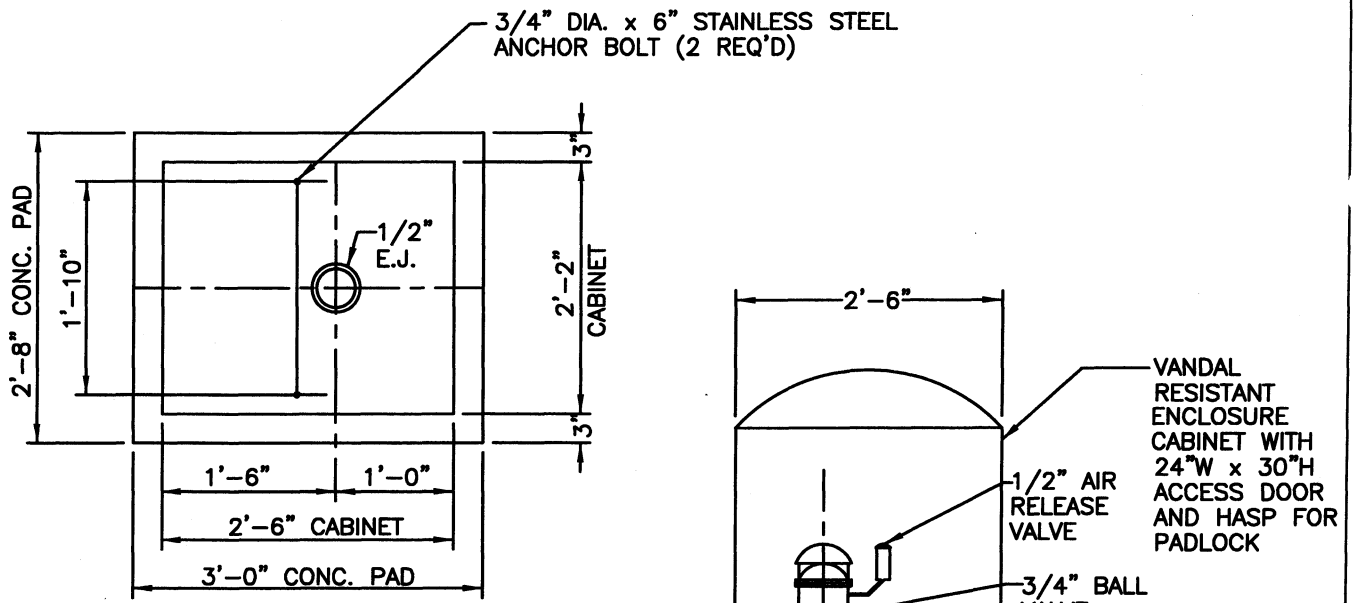

NOTE:  
ALL EXPOSED EDGES OF CONCRETE SHALL HAVE 1/2" CHAMFER.

MANATEE COUNTY PUBLIC WORKS DEPARTMENT		COMBINATION AIR/VACUUM & AIR RELEASE ASSY. FOR 18" & LARGER MAINS	UW-19
REV. BY RTH	DATE 11/99		
MARCH 18, 1997 DATE OF APPROVAL			



TABLE OF CONTENTS

UTILITY STANDARDS—WATER DISTRIBUTION SYSTEM

UW-0	COVER
UW-1	INTRODUCTION – MANATEE COUNTY UTILITY STANDARDS
UW-2	TABLE OF CONTENTS—WATER DISTRIBUTION
UW-3	SYMBOLS—WATER CONSTRUCTION
UW-4	GATE VALVE, BOX, COVER AND TAG
UW-5	TYPICAL FIRE HYDRANT ASSEMBLY
UW-6	JACK & BORE UNDER COUNTY OWNED ROADS
UW-7	CARRIER & CASING DETAIL FOR F.D.O.T. ROADS & RAILROAD CROSSINGS
UW-8	TYPICAL WATER/SEWER CROSSING
UW-9	TYPICAL CANAL CROSSING
UW-10	1 1/2" & 2" METER & BACKFLOW PREVENTER DETAIL
UW-10A	3/4" & 1" METER & BACKFLOW PREVENTER DETAIL
UW-11	END OF LINE 2" BLOW-OFF ASSEMBLY
UW-12	4" AND LARGER BLOW-OFF ASSEMBLY
UW-13	TYPICAL WATER SERVICE CONNECTION
UW-14	THRUST BLOCK DETAILS
UW-14A	RESTRAINED JOINT PIPE LENGTHS FOR PVC
UW-14B	RESTRAINED JOINT PIPE LENGTHS FOR DIP
UW-15	TAPPING SLEEVE & VALVE BLOCKING DETAIL
UW-16	SINGLE WATER SERVICE
UW-16A	SINGLE FIRE LINE SERVICE
UW-17	CUL-DE-SAC DETAIL
UW-18	FIRE HYDRANT BLOW-OFF ASSEMBLY
UW-19	COMBINATION AIR/VACUUM & AIR RELEASE ASSEMBLY FOR 18" & LARGER MAINS
UW-20	MULTIPLE METER VAULT DETAIL
UW-21	COPPER METER YOKE DETAIL FOR 5/8" x 3/4", 3/4" & 1" METERS
UW-22	3" AND ABOVE MASTER METER DETAIL
UW-22A	3" AND ABOVE FIRE SERVICE METER DETAIL
UW-23	BELOW GRADE AIR RELEASE VALVE
UW-24	TYPICAL FIRE HYDRANT WITH LOCKED 90° BEND
UW-25	FIRE LINES 3" DIAMETER AND ABOVE BACKFLOW PREVENTER
UW-26	TRENCH DETAIL—UNIMPROVED SURFACE, TYPE A-1 PIPE BEDDING
UW-27	TRENCH DETAIL—ASPHALT PAVEMENT SURFACE, TYPE A-1 PIPE BEDDING
UW-28	TRENCH DETAIL—CONCRETE PAVEMENT SURFACE, TYPE A-1 PIPE BEDDING
UW-29	TRENCH DETAIL—TYPE A-2 PIPE BEDDING
UW-30	TRENCH DETAIL—TYPE A-3 PIPE BEDDING
UW-31	DIRECTIONAL BORE ROADWAY CROSSING
UW-32	DIRECTIONAL BORE CANAL CROSSING

NOTE:

WATER WORKS SHALL BE DESIGNED IN ACCORDANCE WITH F.D.E.P. REGULATIONS AND "RECOMMENDED STANDARDS FOR WATER WORKS" BY THE GREAT LAKES—UPPER MISSISSIPPI RIVER BOARD OF STATE PUBLIC HEALTH AND ENVIRONMENTAL MANAGERS LATEST EDITION.

MANATEE COUNTY PUBLIC WORKS DEPARTMENT		TABLE OF CONTENTS WATER DISTRIBUTION	UW-2
REV. BY	DATE		
RTH	11/99		
MARCH 18, 1997 DATE OF APPROVAL			

BRASS DISC (1" MIN. DIA.) INDICATING UNIT NUMBER OR ADDRESS SHALL BE INSTALLED AT EACH WATER METER BY DEVELOPER/APPLICANT.

6'-0" (MAX.)

NOTE: DIMENSION WILL VARY WITH NUMBER OF METERS.

#4 PERIMETER BAR LAPPED 16" @ CORNERS

4" SIDEWALK AS REQUIRED

FINISHED GRADE

2" TYP.

1/4" ALUMINIUM ACCESS COVER (TO BE MARKED WATER)

1-#4 @ 16" O.C. (TYPICAL)

6" MIN.

RIVER GRAVEL (OR EQUAL)

12" TYP.

8" POURED CONCRETE OR 8" CONCRETE BLOCK WALLS CORES FILLED WITH CONCRETE.

3/4", 1" GATE VALVE (TYPICAL)

BY OTHERS (TYPICAL)

ALUMINIUM ACCESS COVER (TO BE MARKED WATER)

5/8", 3/4" & 1" WATER METER INSTALLATION BY MCPWD (TYPICAL)

4'-0"

3'-0"

2" TYP.

6"

2'-8"

2" TYP.

COPPER PIPE

GATE VALVE, BOX & COVER

COPPER WITH BRASS OR COPPER FITTINGS OR TYPE "L" COPPER SERVICE (TYPICAL)

ALUMINIUM HINGE (TYPICAL)

CURB STOP W/LOCKING WINGS (TYPICAL)

POLYETHYLENE SERVICE PIPE MEETING AWWA C-901, SHALL BE POLY-E DRISCOPIPE 5100 ULTRA-LINE OR ENDOPURE BY ENDOT OR APPROVED EQUAL. PIPE SHALL BE BLUE OR ENCASED IN BLUE SLEEVE.

**NOTES:**

1. SEE DETAIL UW-10A FOR BACKFLOW PREVENTERS THAT MAY BE REQUIRED DOWN STREAM OF THE METERS.
2. ALUMINIUM ACCESS COVER SHALL HAVE RECESSED LIFTING HANDLES AND BE CAPABLE OF SUPPORTING A SUPER-IMPOSED LOAD OF 75 P.S.F.

MANATEE COUNTY  
PUBLIC WORKS DEPARTMENT

REV. BY	DATE
RTH	11/99

MARCH 18, 1997

DATE OF APPROVAL

MULTIPLE METER  
VAULT DETAIL

UW-20

CAST IRON OVAL METER BOX, 19"L x 10"D  
 ROME 1910 OR APPROVED EQUAL  
 EPOXY PAINTED BLUE AND  
 MARKED WATER

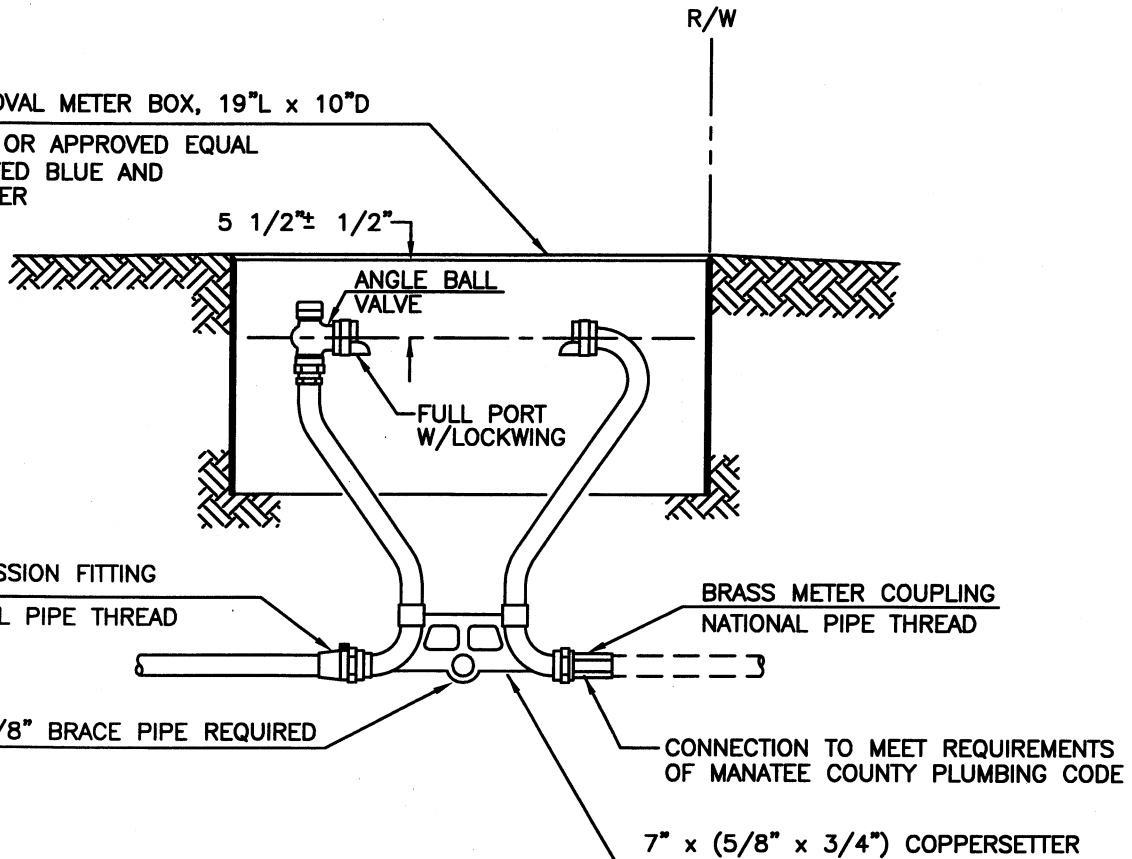

**NOTES:**

1. REFERENCE UW-13 FOR COMPLETE SERVICE CONNECTION ASSEMBLY.
2. FORD 70 SERIES, MUELLER B-2434 OR APPROVED EQUAL. COPPER INLET W/ANGLE BALL VALVE, FIP OUTLET MIN. 7" HGT. ALL VALVES SHALL BE FULL PORT 5/8"x 3/4", OR 3/4" OR 1" METERS. (CHECK VALVES SHOULD NOT BE USED)
3. METER BOX AND YOKE ARE TO BE INSTALLED BY THE INFRASTRUCTURE CONTRACTOR AND SHALL NOT BE SET IN DRAINAGE SWALES, EASEMENTS, SIDEWALKS OR DRIVEWAYS.

7" x (5/8" x 3/4") COPPERSETTER  
 FORD 70 SERIES, MUELLER  
 B-2434 OR APPROVED EQUAL.  
 LOCKING CAMS ON CURB STOP

MANATEE COUNTY  
 PUBLIC WORKS DEPARTMENT

COPPER METER YOKE  
 DETAIL FOR  
 5/8" x 3/4",  
 3/4" & 1" METERS

UW-21

REV.BY	DATE
RTH	11/99

MARCH 18, 1997  
 DATE OF APPROVAL

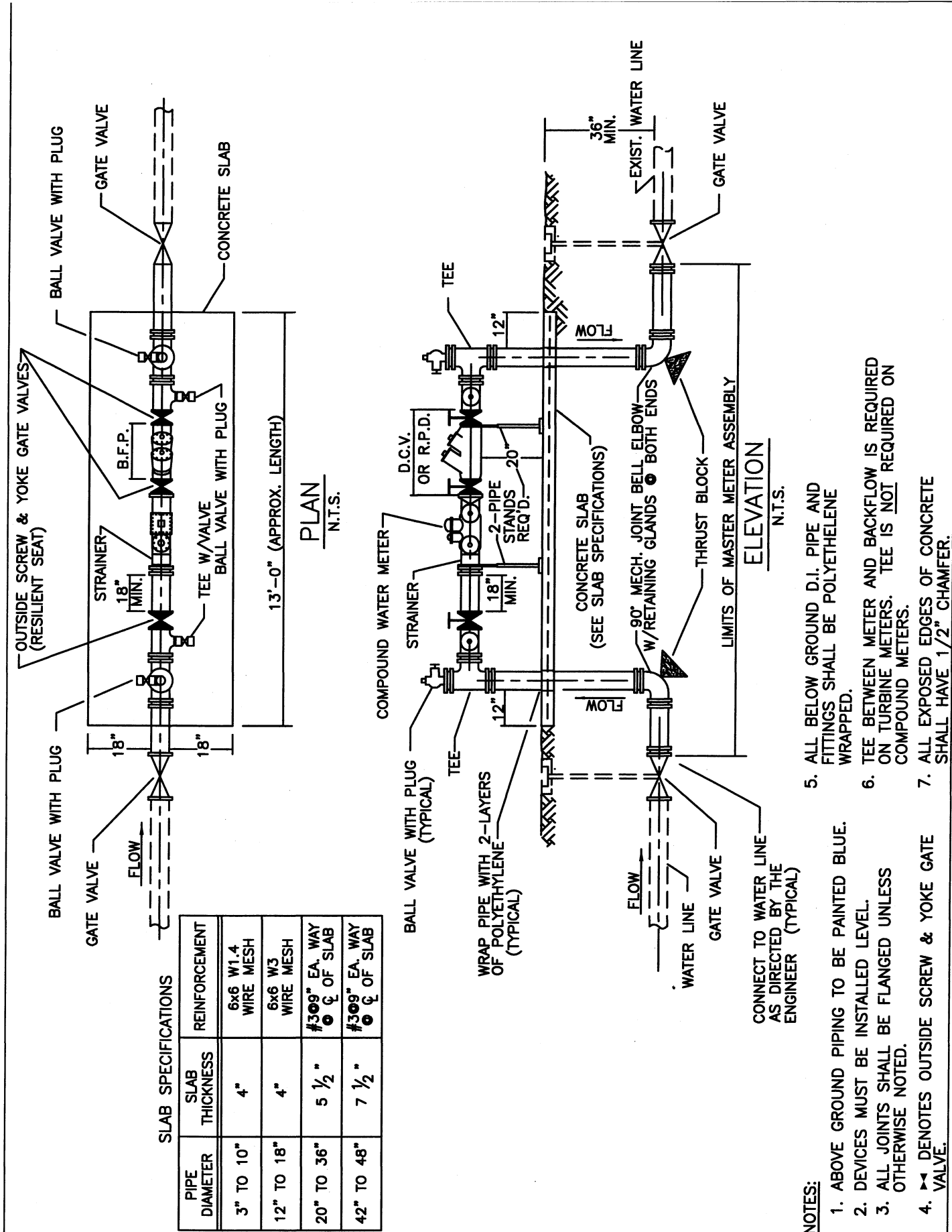

PLAN  
N.T.S.  
13'-0" (APPROX. LENGTH)

ELEVATION  
N.T.S.

SLAB SPECIFICATIONS

PIPE DIAMETER	SLAB THICKNESS	REINFORCEMENT
3" TO 10"	4"	6x6 W1.4 WIRE MESH
12" TO 18"	4"	6x6 W3 WIRE MESH
20" TO 36"	5 1/2"	#309" EA. WAY @ C OF SLAB
42" TO 48"	7 1/2"	#309" EA. WAY @ C OF SLAB

- NOTES:
1. ABOVE GROUND PIPING TO BE PAINTED BLUE.
  2. DEVICES MUST BE INSTALLED LEVEL.
  3. ALL JOINTS SHALL BE FLANGED UNLESS OTHERWISE NOTED.
  4. <math>\nabla</math> DENOTES OUTSIDE SCREW & YOKE GATE VALVE.
  5. ALL BELOW GROUND D.I. PIPE AND FITTINGS SHALL BE POLYETHYLENE WRAPPED.
  6. TEE BETWEEN METER AND BACKFLOW IS REQUIRED ON TURBINE METERS. TEE IS NOT REQUIRED ON COMPOUND METERS.
  7. ALL EXPOSED EDGES OF CONCRETE SHALL HAVE 1/2" CHAMFER.

MANATEE COUNTY  
PUBLIC WORKS DEPARTMENT

REV. BY	DATE
RTH	11/99

MARCH 18, 1997  
DATE OF APPROVAL

3" AND ABOVE  
MASTER METER DETAIL

UW-22

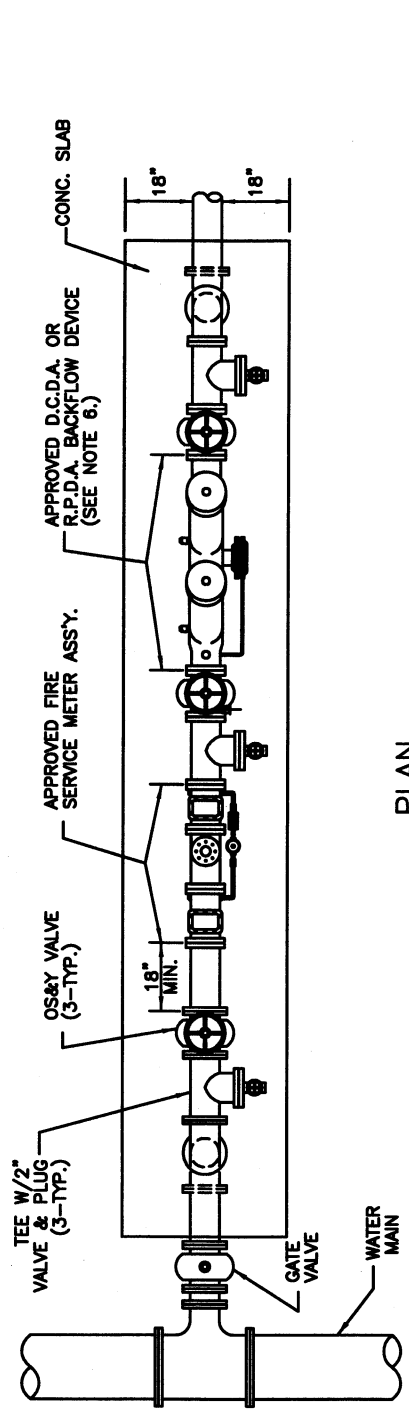

PLAN

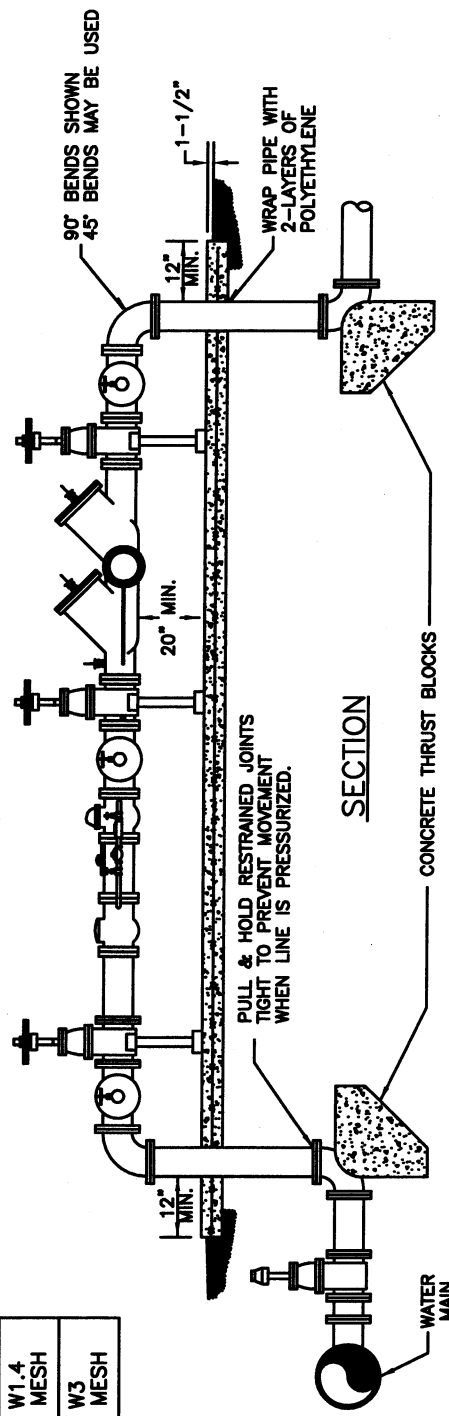

SECTION

SLAB DETAILS

PIPE DIAMETER	SLAB THICKNESS	REINFORCEMENT
3" TO 10"	4"	6x6 W1.4 WIRE MESH
12" TO 18"	4"	6x6 W3 WIRE MESH

NOTES:

1. ABOVE GROUND PIPING TO BE PAINTED BLUE.
2. DEVICES MUST BE INSTALLED LEVEL.
3. ABOVE GROUND JOINTS SHALL BE FLANGED BELOW GROUND JOINTS SHALL BE RESTRAINED PRESSURE TEST FIRE LINE AGAINST DOWNSTREAM GATE VALVE. TEST PRESSURE SHALL NOT BE LESS THAN 180 P.S.I.
4. ABOVE GROUND D.I. PIPE AND FITTINGS SHALL BE POLYETHYLENE WRAPPED.
5. THE SYSTEM MUST MEET THE LATEST REQUIREMENTS OF THE MANATEE COUNTY PLUMBING CODE, THE MANATEE COUNTY BACKFLOW PREVENTION CODE AND THE MANATEE COUNTY FIRE MARSHALL REQUIREMENTS.
6. SOIL BELOW CONCRETE SLAB SHALL BE COMPACTED TO 95% MODIFIED PROCTER.
7. SLAB REINFORCEMENT SHALL BE PLACED ON 2" HIGH CHAIRS.
8. CONCRETE STRENGTH  $f_c$  = 3000 P.S.I.
9. ALL EXPOSED EDGES OF CONCRETE SHALL HAVE 1/2" CHAMFER.

MANATEE COUNTY  
PUBLIC WORKS DEPARTMENT

REV.BY	DATE
RTH	11/99

MARCH 18, 1997  
DATE OF APPROVAL

3" & ABOVE  
FIRE SERVICE METER

UW-22A

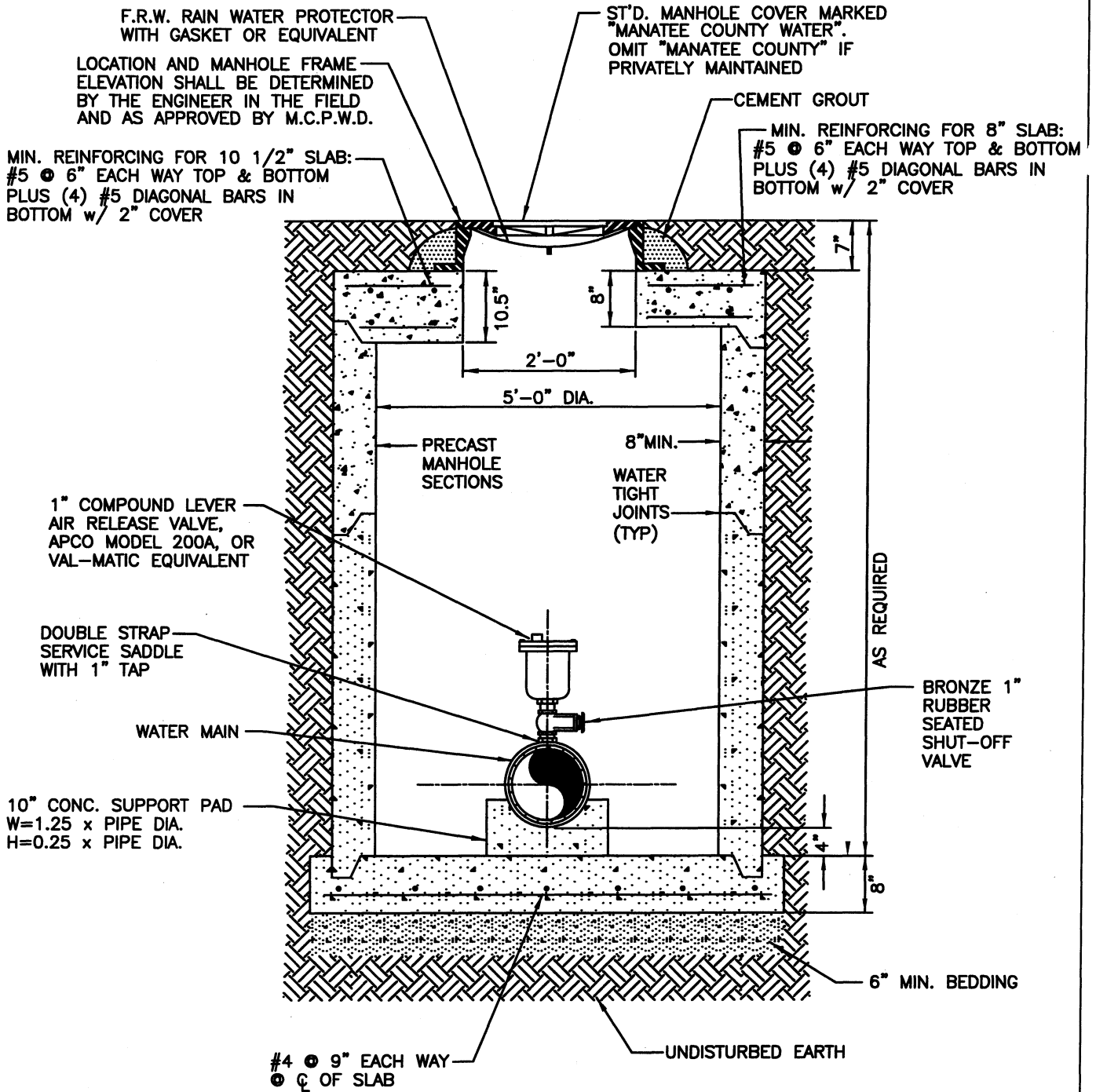

**NOTES:**

- 1.) WHEREVER POSSIBLE AIR RELEASE VALVES SHALL BE PLACED ABOVE GROUND IN STAINLESS STEEL CABINET.
- 2.) ALL PIPE STUBS, NIPPLES AND HARDWARE TO BE 304 STAINLESS STEEL
- 3.) TO PREVENT DAMAGE TO VALVE FROM TIPPED MANHOLE COVERS IN SHALLOW BOXES IT MAY BE NECESSARY TO OFFSET VALVE FROM CENTERLINE.
- 4.) AIR RELEASE VALVES TO BE INSTALLED AT HIGH POINTS OF MAIN AS DIRECTED BY THE ENGINEER.
- 5.) ALL PIPE APPURTENANCES AND SIZING IN ACCORDANCE WITH SPECIFIC DEVICE APPLICATION.
- 6.) WHERE AIR RELEASE VALVE IS 12' OR FURTHER FROM CURB OR SHOULDER OF ROADWAY SERIES H1R3030 ACCESS DOOR OR APPROVED EQUAL MAY BE USED.

<b>MANATEE COUNTY</b> PUBLIC WORKS DEPARTMENT		<b>BELOW GRADE AIR RELEASE VALVE</b>	<b>UW-23</b>
REV. BY RTH	DATE 11/99	<b>MARCH 18, 1997</b> DATE OF APPROVAL	

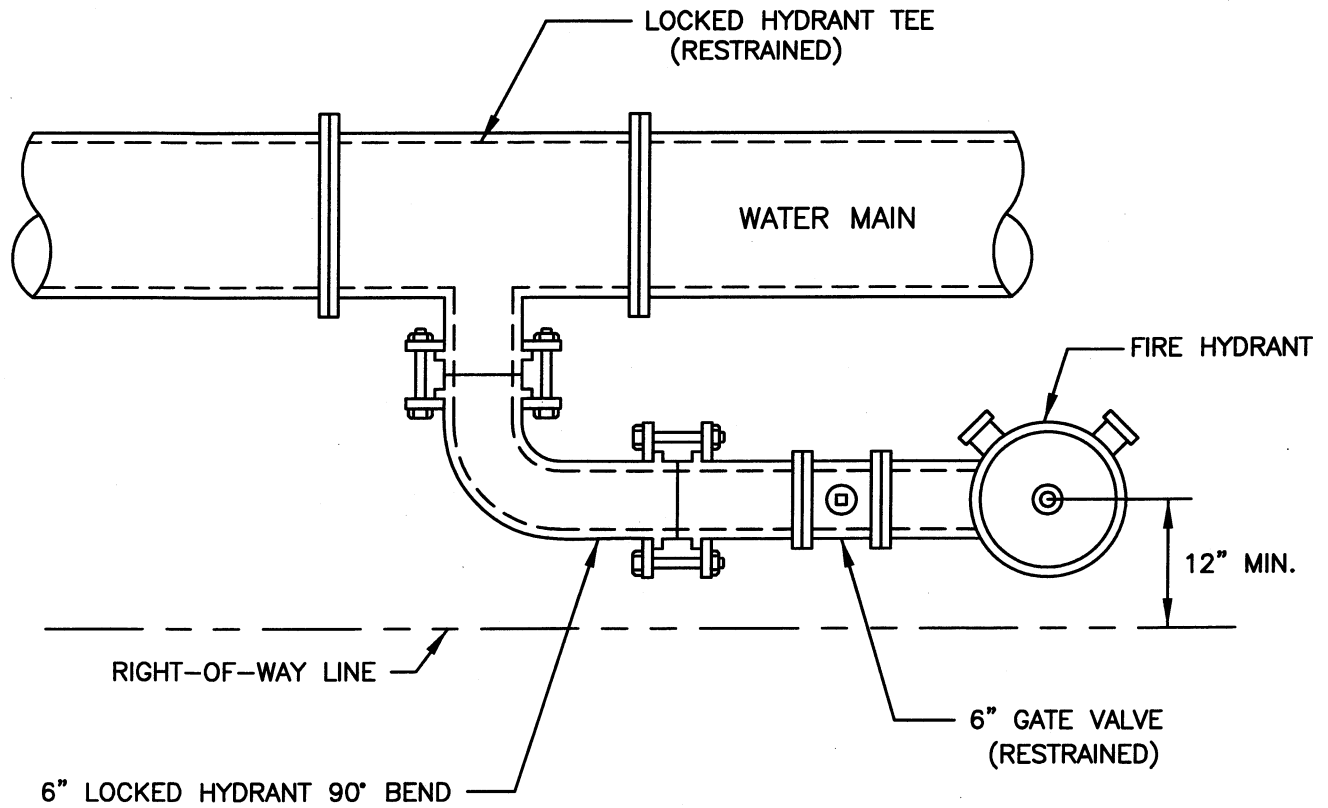

PLAN

NOTE:

THIS DETAIL FOR USE ONLY WHEN THE WATER MAIN IS LOCATED TOO CLOSE TO THE RIGHT-OF-WAY LINE TO USE DETAIL UW-5.

MANATEE COUNTY PUBLIC WORKS DEPARTMENT		TYPICAL FIRE HYDRANT WITH LOCKED 90° BEND	UW-24
REV. BY	DATE		
	MARCH 18, 1997		
	DATE OF APPROVAL		

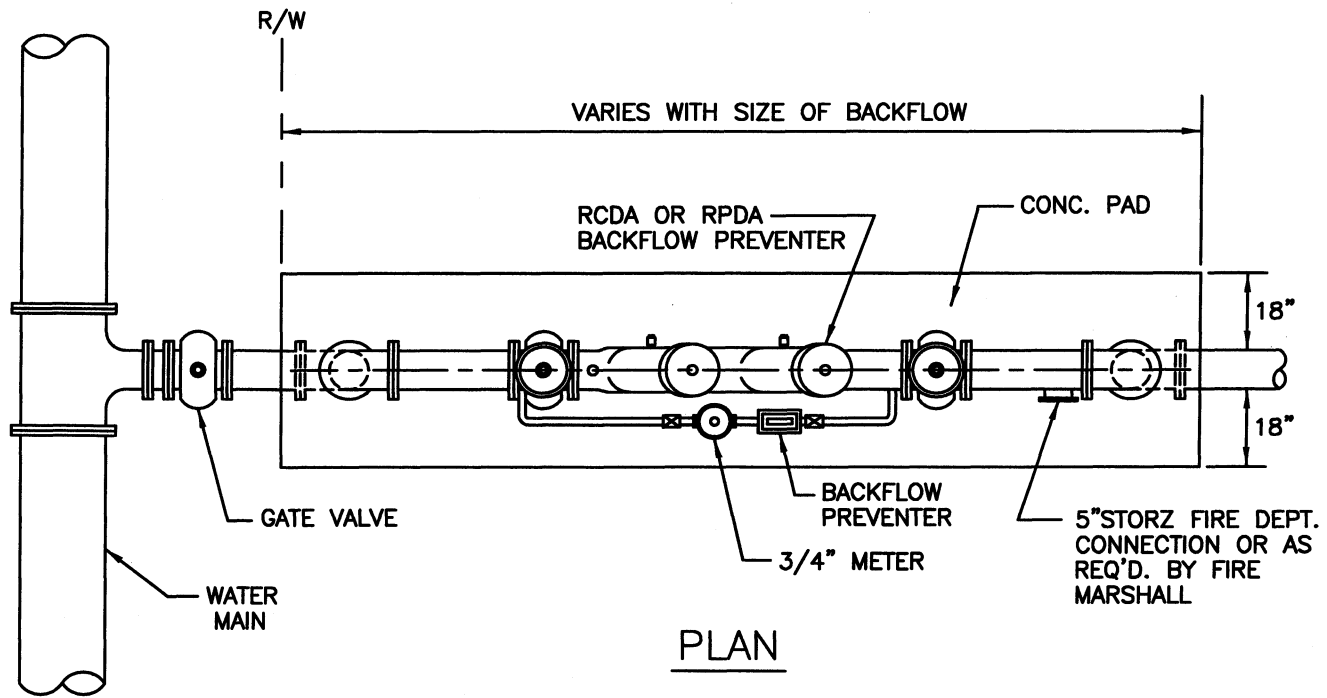

PLAN

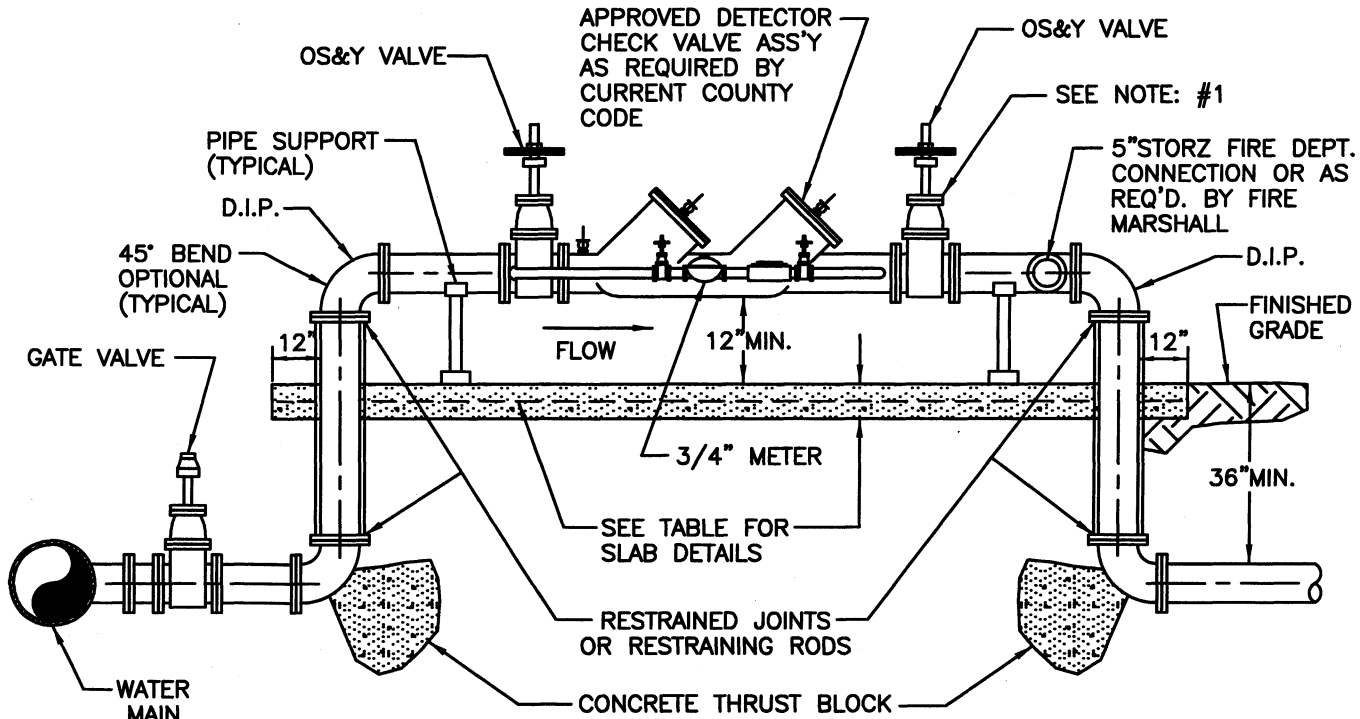

SECTION

NOTES:

1. WHEN PRESSURE TESTING FIRE LINE, TEST AGAINST DOWNSTREAM GATE VALVE.
2. THE SYSTEM MUST MEET ALL REQUIREMENTS OF THE MANATEE COUNTY PLUMBING CODE (LATEST EDITION) AND THE MANATEE COUNTY BACKFLOW PREVENTION CODE (LATEST EDITION), AND THE MANATEE COUNTY FIRE MARSHALL REQUIREMENTS.
3. PAINT BACKFLOW ASSEMBLY RED.
4. ALL EXPOSED EDGES OF CONCRETE SHALL HAVE 1/2" CHAMFER.

SLAB DETAILS

PIPE DIAMETER	SLAB THICKNESS	REINFORCEMENT
3" TO 10"	4"	6x6 W1.4 WIRE MESH
12" TO 18"	4"	6x6 W3 WIRE MESH

<b>MANATEE COUNTY</b> PUBLIC WORKS DEPARTMENT		<b>3" AND ABOVE FIRE LINES</b> <b>BACKFLOW PREVENTER</b>	<b>UW-25</b>
REV. BY	DATE		
RTH	11/99	MARCH 18, 1997	
		DATE OF APPROVAL	



**NOTES:**

- 1.) USE OF TYPE A-2 AND A-3 PIPE BEDDING TO BE DETERMINED IN THE FIELD BY THE ENGINEER.
- 2.) 10" MAX. FOR PIPE DIAMETER LESS THAN 24"; 12" MAX. FOR PIPE DIAMETER 24" AND LESS THAN 42"; 24" MAX. FOR PIPE DIAMETER 42" AND OVER.
- 3.) 4" MAX. FOR PIPE 16" DIAMETER & LESS; 6" MAX. FOR PIPE 18" TO 36" DIAMETER; AND 9" MAX FOR PIPE 42" DIAMETER AND LARGER.
- 4.) INSTALLATION SHALL BE IN ACCORDANCE WITH THE MANUFACTURER'S SPECIFICATIONS.

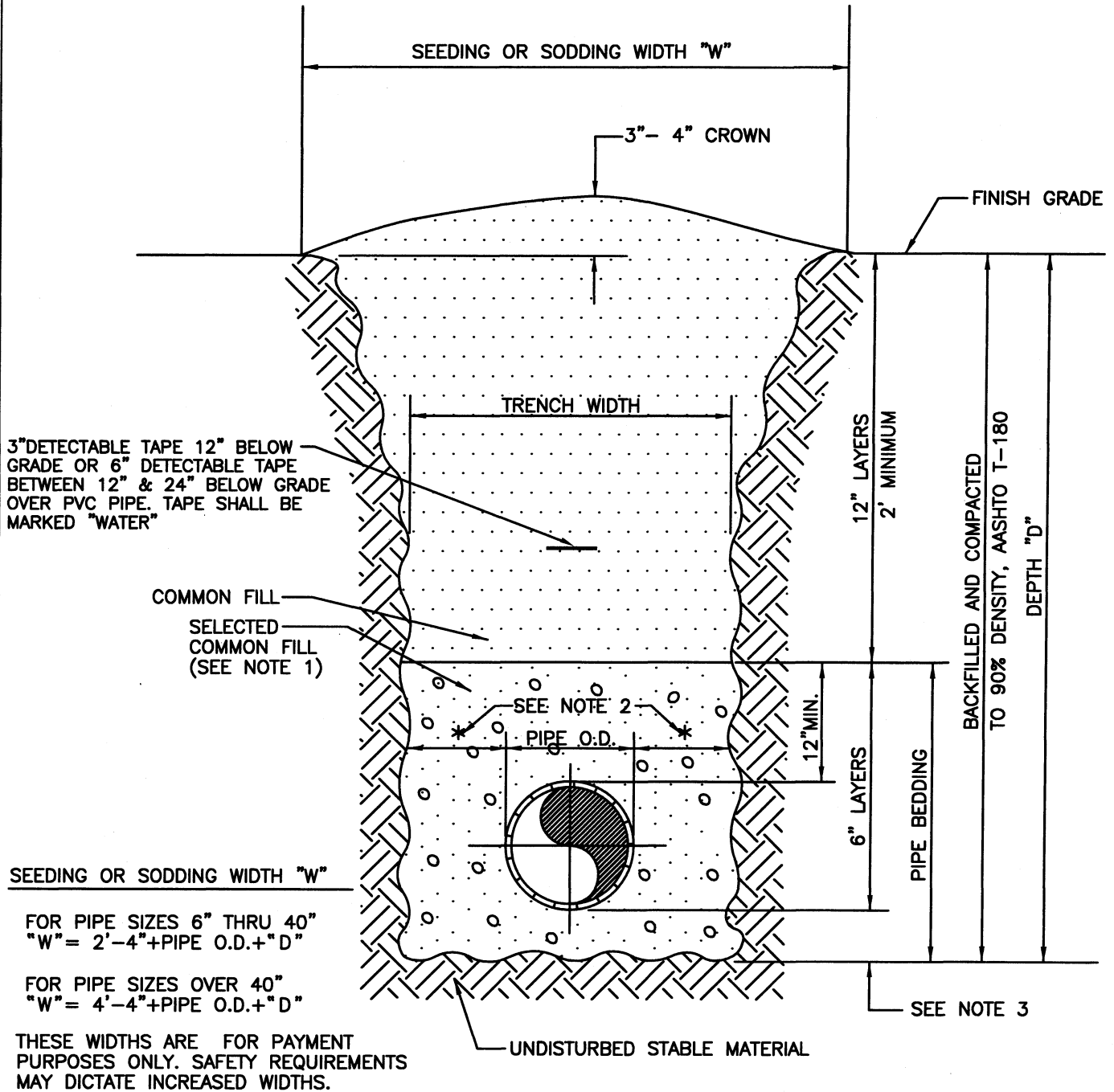

MANATEE COUNTY PUBLIC WORKS DEPARTMENT		TRENCH DETAIL UNIMPROVED SURFACE TYPE A-1 PIPE BEDDING		UW-26
REV. BY	DATE	MARCH 18, 1997 DATE OF APPROVAL		
RTH	11/99			

**NOTES:**

- 1.) USE OF TYPE A-2 AND A-3 PIPE BEDDING TO BE DETERMINED IN THE FIELD BY THE ENGINEER.
- 2.) 10" MAX. FOR PIPE DIAMETERS LESS THAN 24"; 12" MAX. FOR PIPE DIAMETER 24" AND LESS THAN 42"; 24" MAX. FOR PIPE DIAMETER 42" AND OVER.
- 3.) 4" MAX. FOR PIPE 16" DIAMETER & LESS; 6" MAX. FOR PIPE 18" TO 36" DIAMETER; AND 9" MAX. FOR PIPE 42" DIAMETER AND LARGER.
- 4.) INSTALLATION SHALL BE IN ACCORDANCE WITH THE MANUFACTURER'S SPECIFICATIONS.
- 5.) WEARING SURFACE TO BE SAME TYPE & THICKNESS (1½" MIN.) AS EXISTING PAVEMENT.
- 6.) SHEETING ORDERED LEFT IN PLACE TO BE CUT OFF 24" BELOW FINISHED GRADE OR 12" BELOW SUBGRADE.
- 7.) BASE SHALL BE 6" MINIMUM THICKNESS SAND ASPHALT, 10" MIN. THICKNESS CRUSHED CONCRETE, OR APPROVED EQUAL.
- 8.) BACKFILL AASHTO M-145 SHALL BE PLACED IN LAYERS NOT TO EXCEED 6 INCHES. EACH LAYER SHALL BE THOROUGHLY TAMPED AND/OR ROLLED TO 98% AASHTO T-180 DENSITY.
- 9.) TEMPORARY PATCHES WILL BE INSTALLED TO PROVIDE A SMOOTH ALL WEATHER SURFACE AT ALL TIME. PERMANENT REPLACEMENT TO BE MADE AS SOON AS POSSIBLE.
- 10.) NOTES 5.) THRU 9.) ARE MINIMUM REQUIREMENTS. REFER TO MANATEE COUNTY TRANSPORTATION DEPARTMENT STANDARDS FOR ADDITIONAL REQUIREMENTS.

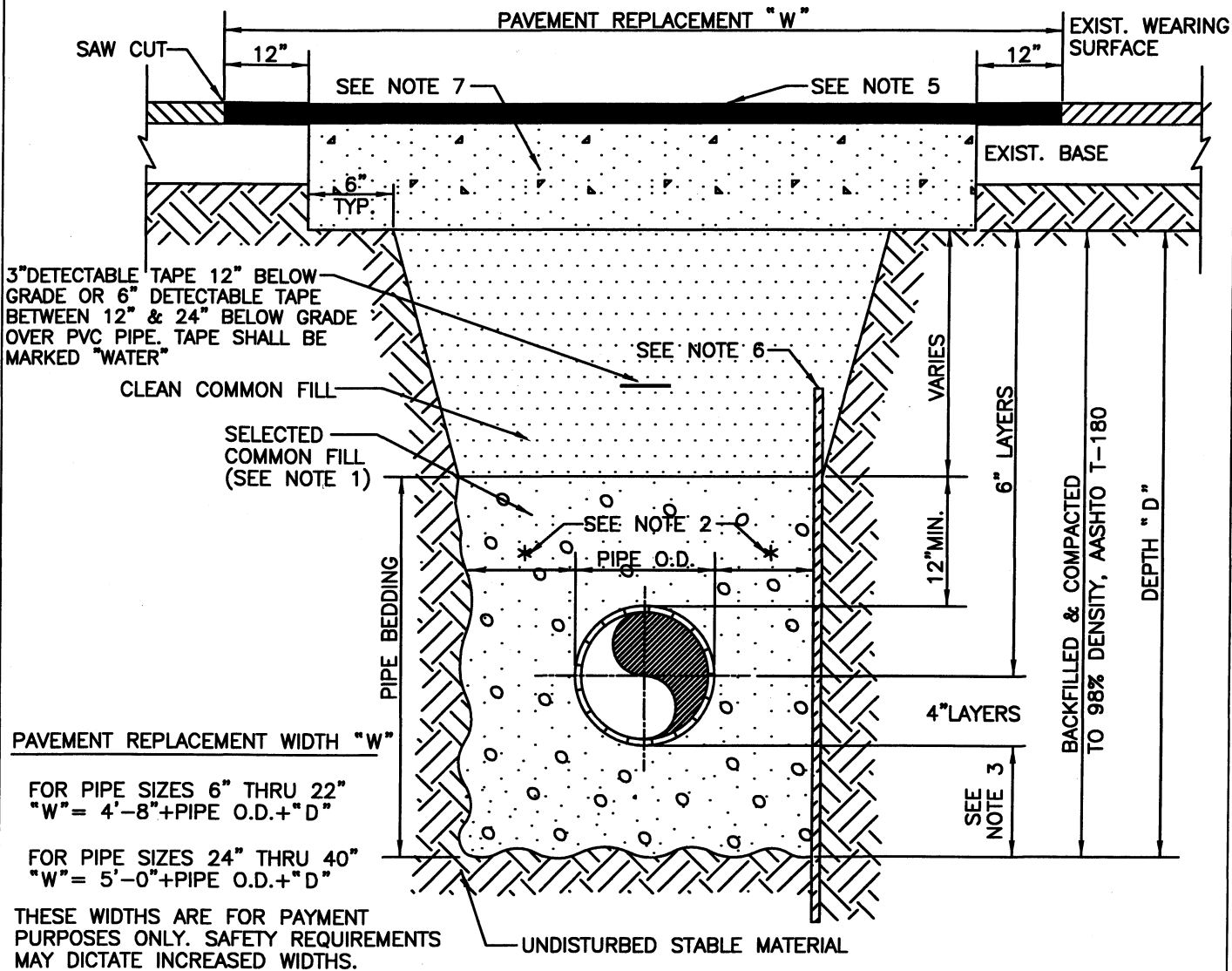

MANATEE COUNTY PUBLIC WORKS DEPARTMENT		TRENCH DETAIL		UW-27
REV. BY	DATE	ASPH. PAVEMENT SURFACE		
RTH	11/99	TYPE A-1 PIPE BEDDING		
MARCH 18, 1997				
DATE OF APPROVAL				

**NOTES:**

- 1.) USE OF TYPE A-2 AND A-3 PIPE BEDDING TO BE DETERMINED IN THE FIELD BY THE ENGINEER.
  - 2.) 10" MAX. FOR PIPE DIAMETER LESS THAN 24"; 12" MAX. FOR PIPE DIAMETER 24" AND LESS THAN 42"; 24" MAX. FOR PIPE DIAMETER 42" AND OVER.
  - 3.) 4" MAX. FOR PIPE 16" DIAMETER & LESS; 6" MAX. FOR PIPE 18" TO 36" DIAMETER; AND 9" MAX. FOR PIPE 42" DIAMETER AND LARGER.
  - 4.) INSTALLATION SHALL BE IN ACCORDANCE WITH THE MANUFACTURER'S SPECIFICATIONS.
  - 5.) THICKNESS TO MATCH EXISTING OR BE 8" MINIMUM, WHICHEVER IS GREATER.
- FOR NOTES 6.) THRU 10.) SEE UW-27

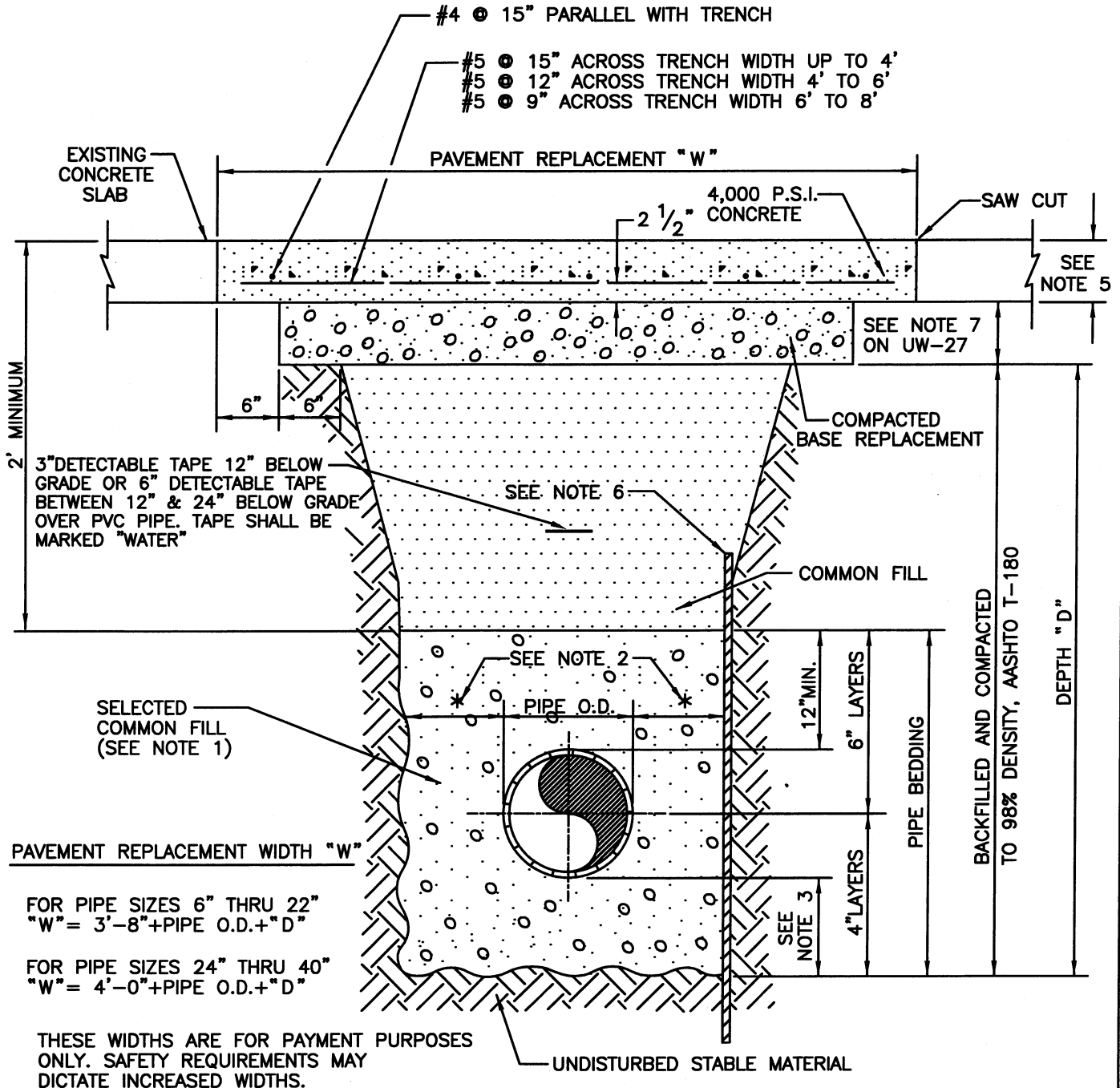

PAVEMENT REPLACEMENT WIDTH "W"

FOR PIPE SIZES 6" THRU 22"  
 "W" = 3'-8" + PIPE O.D. + "D"

FOR PIPE SIZES 24" THRU 40"  
 "W" = 4'-0" + PIPE O.D. + "D"

THESE WIDTHS ARE FOR PAYMENT PURPOSES ONLY. SAFETY REQUIREMENTS MAY DICTATE INCREASED WIDTHS.

MANATEE COUNTY PUBLIC WORKS DEPARTMENT		TRENCH DETAIL CONC. PAVEMENT SURFACE TYPE A-1 PIPE BEDDING	UW-28
REV. BY RTH	DATE 11/99		
MARCH 18, 1997 DATE OF APPROVAL			

NOTES:

- 1.) 10" MAX. FOR PIPE DIAMETER LESS THAN 24"; 12" MAX. FOR PIPE DIAMETER 24" AND LESS THAN 42"; 24" MAX. FOR PIPE DIAMETER 42" AND OVER.
- 2.) 4" MAX. FOR PIPE 16" DIAMETER AND LESS; 6" MAX. FOR PIPE DIAMETER 18" TO 36" AND 9" MAX. FOR PIPE DIAMETER 42" AND OVER.
- 3.) INSTALLATION SHALL BE IN ACCORDANCE WITH MANUFACTURER'S SPECIFICATIONS.

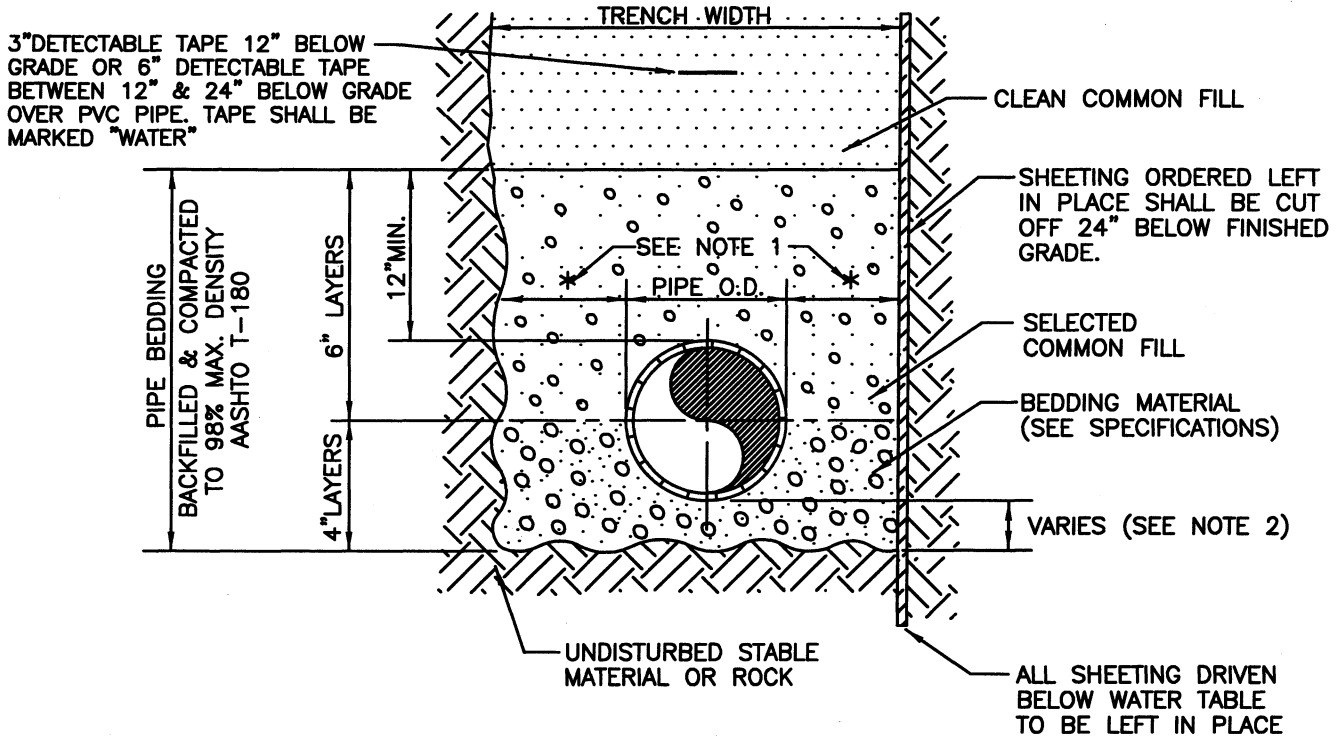

MANATEE COUNTY PUBLIC WORKS DEPARTMENT		TRENCH DETAIL TYPE A-2 PIPE BEDDING	UW-29
REV. BY RTH	DATE 11/99		
MARCH 18, 1997 DATE OF APPROVAL			

	WATER MAIN (PROPOSED)
	WATER MAIN (EXISTING)
	PLUG/CAP
	BLOW-OFF
	VALVE (PROPOSED)
	VALVE (EXISTING)
	BUTTERFLY VALVE
	CHECK VALVE, CLAPPER TYPE
	BACKFLOW, DOUBLE CHECK, REDUCED PRESSURE
	REDUCER FITTING
	PRESSURE REGULATOR
	FITTING WITH THRUST BLOCK
	FIRE HYDRANT ASSEMBLY (EXISTING)
	FIRE HYDRANT ASSEMBLY (PROPOSED)
	SINGLE SERVICE WATER METER (PROPOSED)
	SINGLE SERVICE WATER METER (EXISTING)
	DOUBLE SERVICE WATER METER (PROPOSED)
	GANG WATER METER ASSEMBLY (PROPOSED)
	MANHOLE (PROPOSED)

<b>MANATEE COUNTY</b> PUBLIC WORKS DEPARTMENT		<b>SYMBOLS</b> <b>WATER</b> <b>CONSTRUCTION</b>	UW-3
REV. BY	DATE		
MARCH 18, 1997 DATE OF APPROVAL			

NOTES:

- 1.) 10" MAX. FOR PIPE DIAMETER LESS THAN 24"; 12" MAX. FOR PIPE DIAMETER 24" AND LESS THAN 42"; 24" MAX. FOR PIPE DIAMETER 42" AND OVER.
- 2.) 4" MAX. FOR PIPE 16" DIAMETER & LESS; 6" MAX. FOR PIPE 18" TO 36" DIAMETER; AND 9" MAX FOR PIPE 42" DIAMETER AND LARGER.
- 3.) INSTALLATION SHALL BE IN ACCORDANCE WITH THE MANUFACTURER'S SPECIFICATIONS.

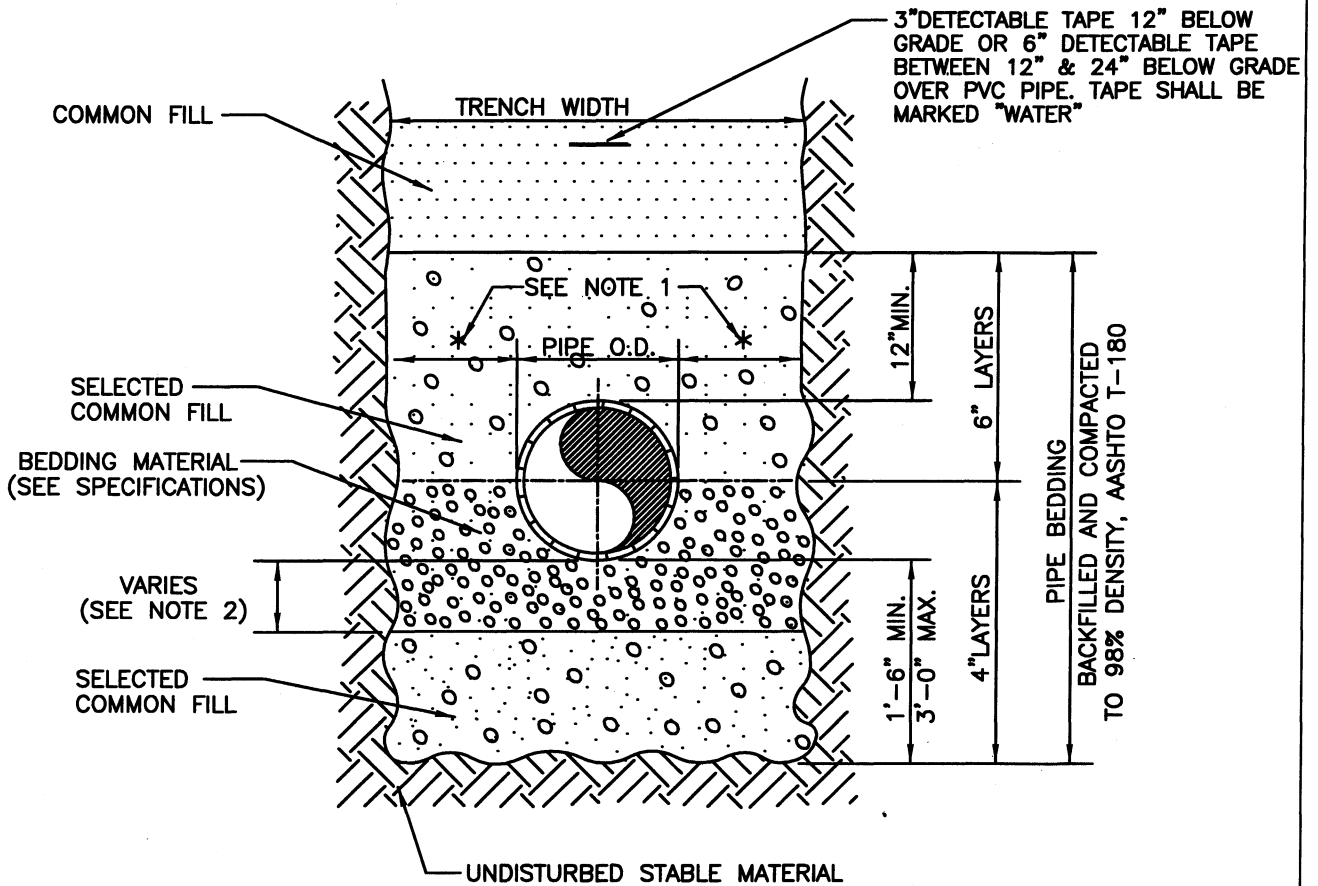

MANATEE COUNTY  
PUBLIC WORKS DEPARTMENT

TRENCH DETAIL

UW-30

REV. BY	DATE
RTH	11/99

MARCH 18, 1997  
DATE OF APPROVAL

TYPE A-3 PIPE BEDDING

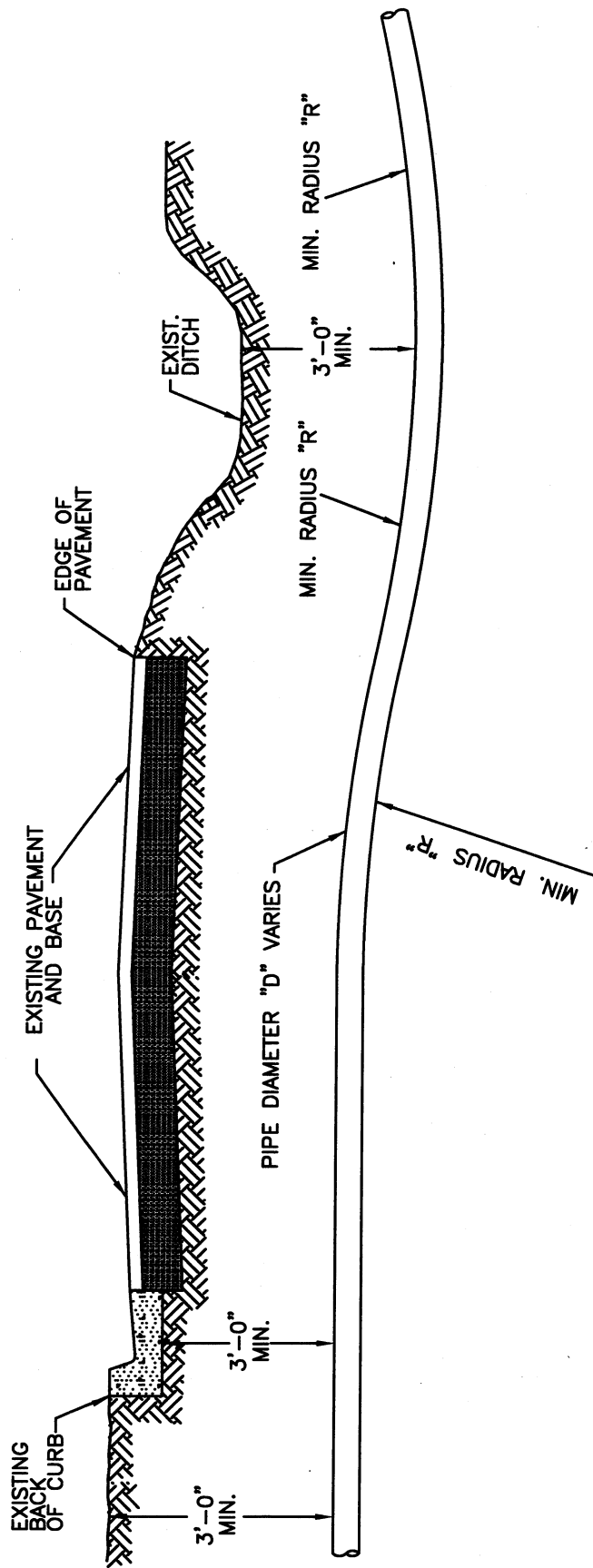

ALL POLYETHYLENE PIPING SHALL MEET MANATEE COUNTY STANDARDS AND SPECIFICATIONS

SDR-9, CLASS 200 FOR POTABLE WATER & RECLAIMED WATER  
 SDR-11, CLASS 160 FOR SANITARY FORCE MAINS  
 COLOR CODED BLUE FOR POTABLE WATER  
 COLOR CODED PURPLE FOR RECLAIMED WATER  
 COLOR CODED GREEN FOR SANITARY FORCE MAIN

PIPE DIAMETER "D" IN INCHES	MIN. RADIUS FOR PE PIPE IN FEET	
	MIN. RADIUS "R" FOR SDR-11	MIN. RADIUS "R" FOR SDR-9
2	4	5.5
3	6	8.3
4	8	11.0
6	12	16.5
8	16	22.0
10	20	27.5
12	24	33.0
16	32	44.0
18	36	49.5
20	40	55.0

MANATEE COUNTY  
 PUBLIC WORKS DEPARTMENT

REV. BY    DATE

NOVEMBER 1, 1999  
 DATE OF APPROVAL

DIRECTIONAL BORE  
 ROADWAY CROSSING

UW-31

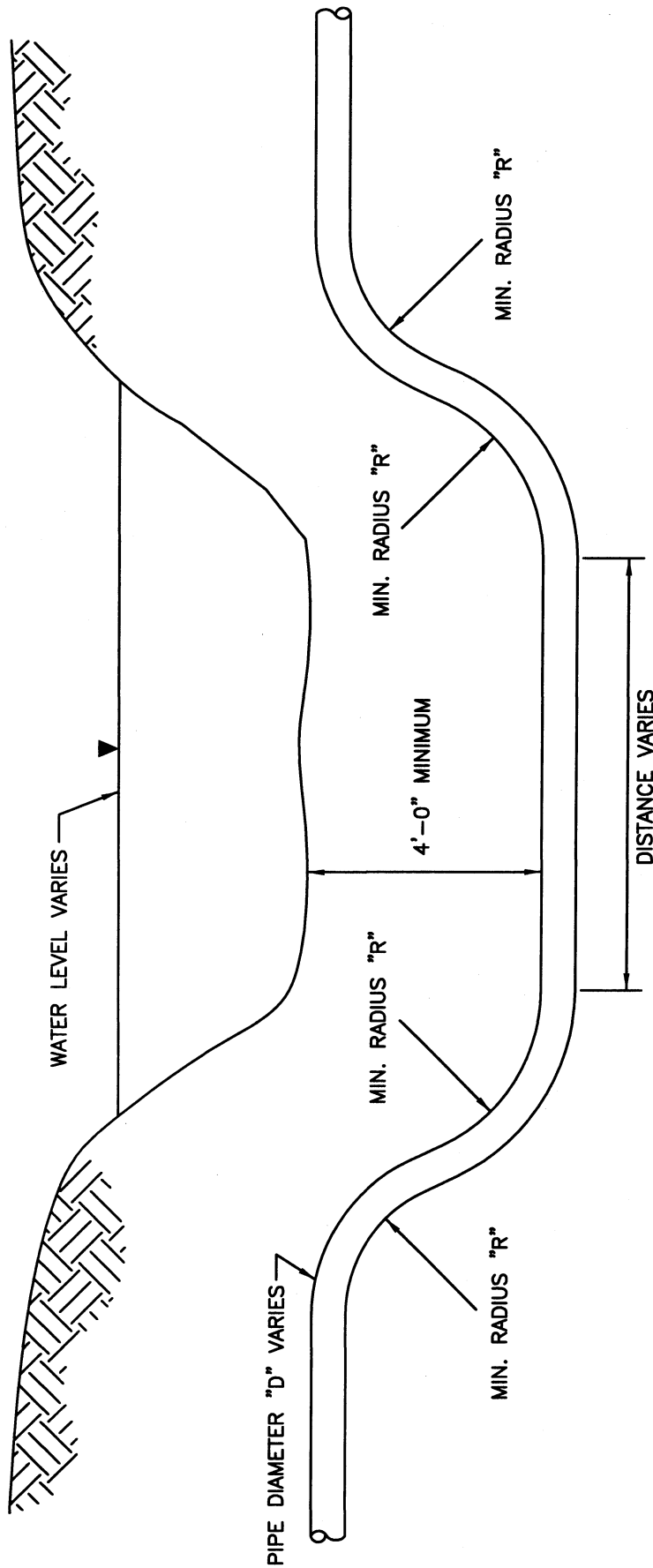

ALL POLYETHYLENE PIPING SHALL MEET MANATEE COUNTY STANDARDS AND SPECIFICATIONS

SDR-9, CLASS 200 FOR POTABLE WATER & RECLAIMED WATER  
 SDR-11, CLASS 160 FOR SANITARY FORCE MAINS  
 COLOR CODED BLUE FOR POTABLE WATER  
 COLOR CODED PURPLE FOR RECLAIMED WATER  
 COLOR CODED GREEN FOR SANITARY FORCE MAIN

PIPE DIAMETER "D" IN INCHES	MIN. RADIUS FOR PE PIPE IN FEET	
	MIN. RADIUS "R" FOR SDR-11	MIN. RADIUS "R" FOR SDR-9
2	4	5.5
3	6	8.3
4	8	11.0
6	12	16.5
8	16	22.0
10	20	27.5
12	24	33.0
16	32	44.0
18	36	49.5
20	40	55.0

MANATEE COUNTY  
 PUBLIC WORKS DEPARTMENT

REV. BY	DATE

NOVEMBER 1, 1999  
 DATE OF APPROVAL

DIRECTIONAL BORE  
 CANAL CROSSING

UW-32



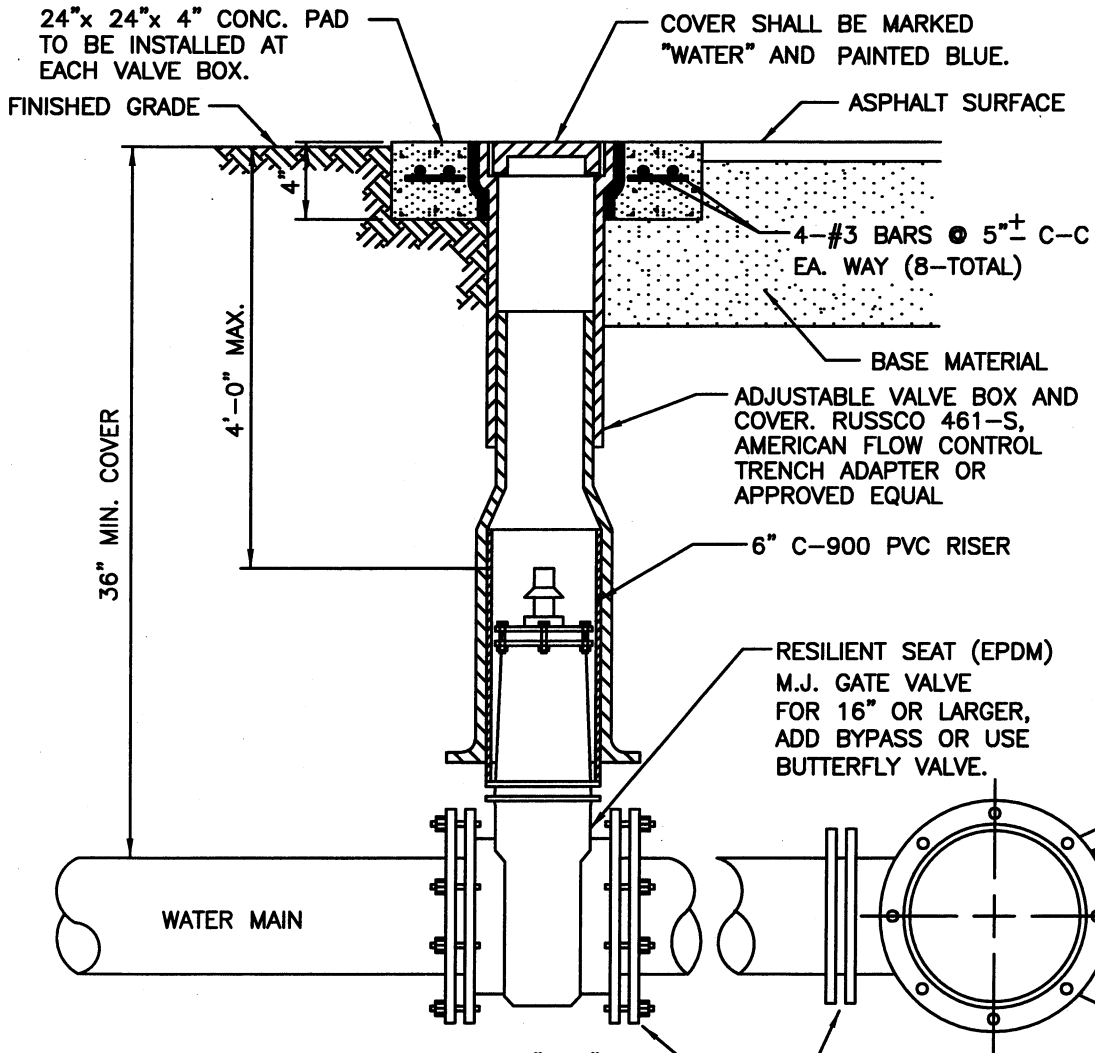
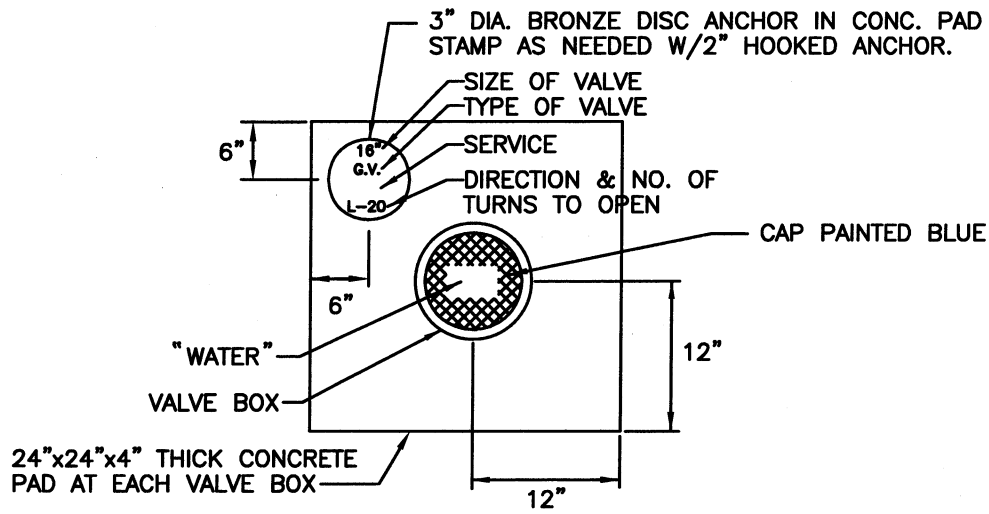

**NOTES:**

1. GATE VALVE TO BE MARKED IN CURB WITH A "WV" WITH A FOOTAGE FROM THE BACK OF CURB TO THE VALVE OR IF NO CURB, A BLUE DISC WITH "WV" IN THE EDGE OF PAVEMENT WITH THE FOOTAGE FROM THE DISC TO THE VALVE.
2. ALL EXISTING AND PROPOSED VALVE BOXES SHALL BE ADJUSTED TO FINISHED GRADES AS ESTABLISHED IN THE FIELD.
3. WATER VALVES SHALL NOT BE PLACED IN HANDICAPPED RAMPS.
4. ALL EXPOSED EDGES OF CONCRETE SHALL BE CHAMFERED 1/2".

MANATEE COUNTY PUBLIC WORKS DEPARTMENT		GATE VALVE, BOX, COVER AND TAG	UW-4
REV. BY	DATE		
RTH	11/99	MARCH 18, 1997	
		DATE OF APPROVAL	

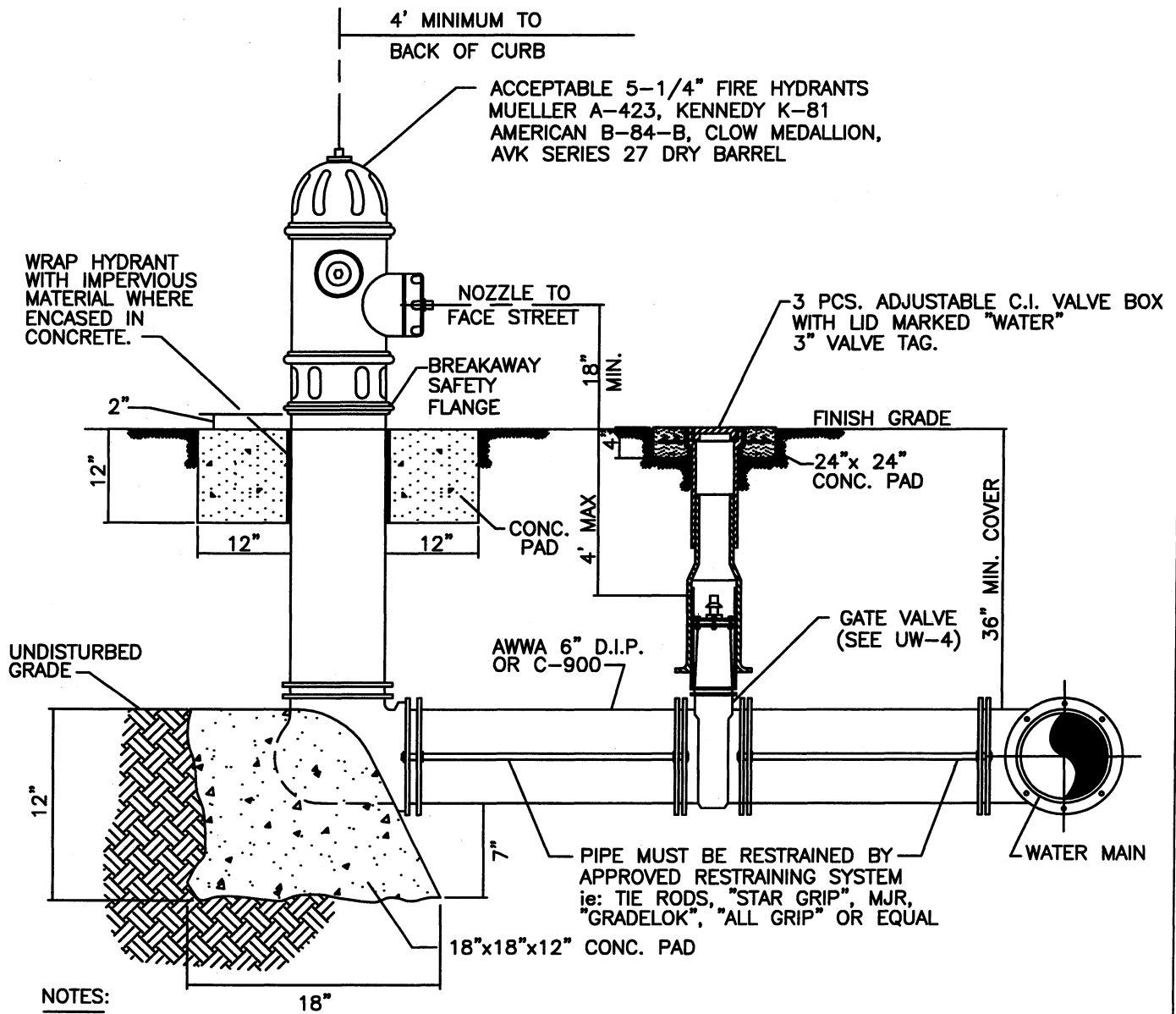

**NOTES:**

1. WEEPHOLES TO BE PLUGGED WITH BRASS PLUGS.
2. FIRE HYDRANTS SHALL BE A MINIMUM OF 6'-0" OFF EDGE OF PAVEMENT AND 10'-0" MAX. FROM BACK OF CURB WHERE POSSIBLE AND WHERE SIDEWALK IS TO BE INSTALLED, SHALL BE LOCATED BETWEEN THE SIDEWALK AND EDGE OF ROAD.
3. HYDRANTS SHALL BE PAINTED SAFETY YELLOW. HYDRANT SHALL BE ALL CAST IRON CONSTRUCTION.
4. PAY ITEMS FOR FIRE HYDRANT ASSEMBLIES SHALL INCLUDE HYDRANT, VALVE, PIPING, MAINLINE TEE & HARNESSING, VALVE BOX & CONCRETE ENCASEMENTS.
5. FIRE HYDRANTS SHALL BE PREFERABLY PLACED SO THAT STORM WATER FLOWS AWAY FROM & NOT TOWARDS THE HYDRANT.
6. FIRE HYDRANTS SHALL BE CONSTRUCTED WITH "GROUND LINE" SET TO FINISHED GRADES AS ESTABLISHED IN THE FIELD. NORMAL BURY IS 3 FEET OF COVER FOR WATER LINES. IF EXTENSIONS ARE REQUIRED, THE COST SHALL BE INCLUDED IN THE PRICE BID.
7. FIRE HYDRANTS MAY BE CONSTRUCTED WITH "GRADELOK" OFFSET FITTING.
8. RAISED REFLECTIVE PAVEMENT MARKER (BLUE) SHALL BE INSTALLED AT CENTERLINE OF PAVEMENT ADJACENT TO EACH HYDRANT.
9. ALL EXPOSED EDGES OF CONCRETE SHALL HAVE 1/2" CHAMFER.

MANATEE COUNTY  
PUBLIC WORKS DEPARTMENT

REV. BY	DATE
RTH	11/99

MARCH 18, 1997  
DATE OF APPROVAL

TYPICAL FIRE  
HYDRANT ASSEMBLY

UW-5

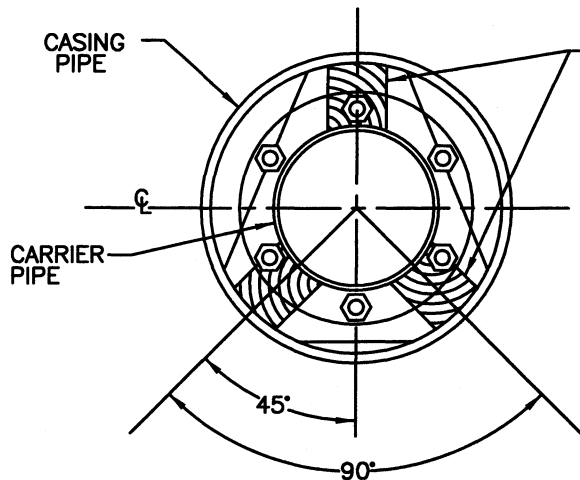
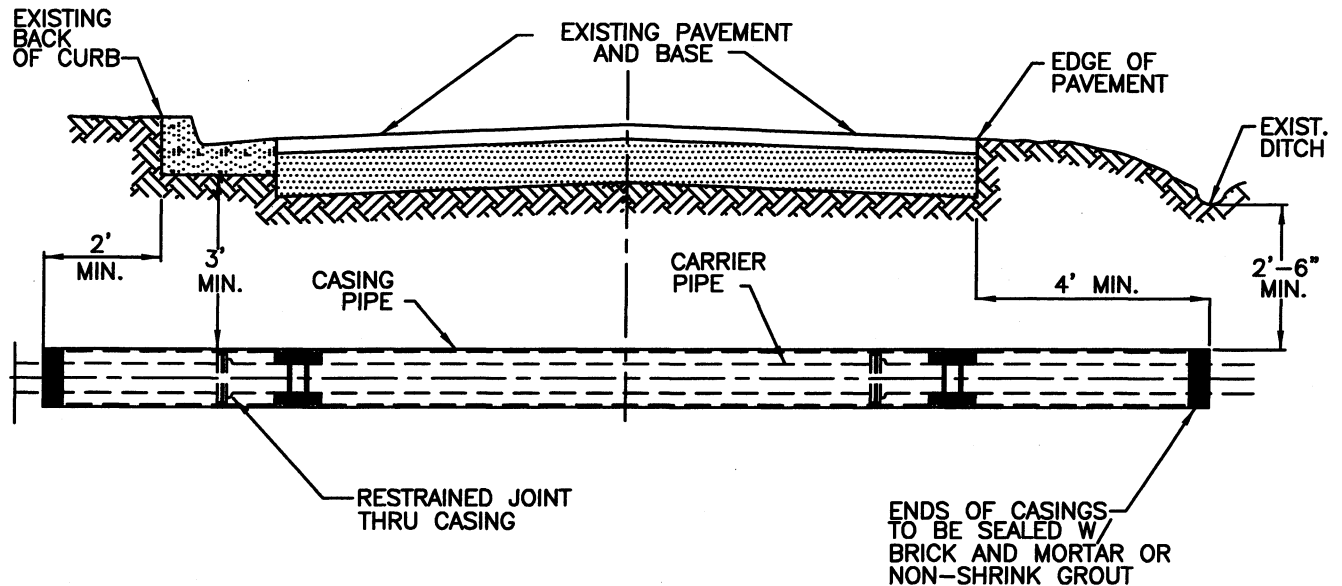

CARRIER PIPE TO BE DUCTILE IRON CLASS 53 OR AWWA C-900 PVC CLASS 150 (DR-18) AS REQUIRED. ALL BLOCKING TO BE PRESSURE TREATED TIMBER. BLOCKING TO BE FASTENED TO BARREL OF CARRIER PIPE BEHIND EACH BELL WITH STAINLESS STEEL BANDING OR 304 STAINLESS STEEL BAND CASING INSULATORS AS MANUFACTURED BY ADVANCE PRODUCTS & SYSTEMS INC. AND PIPELINE SEAL & INSULATOR INC. PLASTIC (HDPE) SPACERS AS MANUFACTURED BY RACI MAY BE USED ON CARRIER PIPE UP TO 12" DIAMETER OR APPROVED EQUAL.

CASING PIPE JOINTS SHALL BE MADE BY USING A FULL CIRCUMFERENCE COMPLETE PENETRATION GROOVE WELD.

CARRIER & CASING SIZE									
CARRIER	4"	6"	8"	10"	12"	14"	16"	18"	20"
CASING	12"	14"	16"	20"	24"	24"	30"	36"	42"
CASING / WALL THICKNESS	0.188	0.188	0.219	0.250	0.344	0.344	0.406	0.406	0.500

MANATEE COUNTY  
PUBLIC WORKS DEPARTMENT

REV. BY	DATE
RTH	11/99

MARCH 18, 1997  
DATE OF APPROVAL

JACK & BORE UNDER  
COUNTY OWNED ROADS

UW-6

DIMENSION AS REQUIRED BY DEPARTMENT OF TRANSPORTATION OR RAILROADS BUT NOT LESS THAN 4'-0"

DIMENSION AS REQUIRED BY F.D.O.T. OR RAILROAD CO. BUT NOT LESS THAN 3'-0"

FINISHED GRADE OF HIGHWAY OR RAILROAD BED

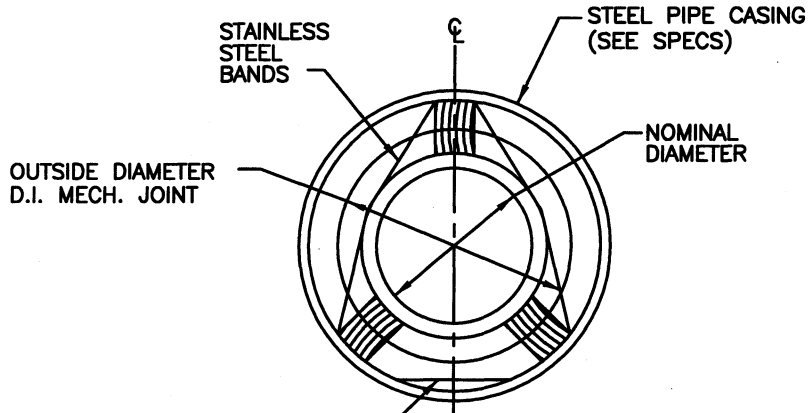
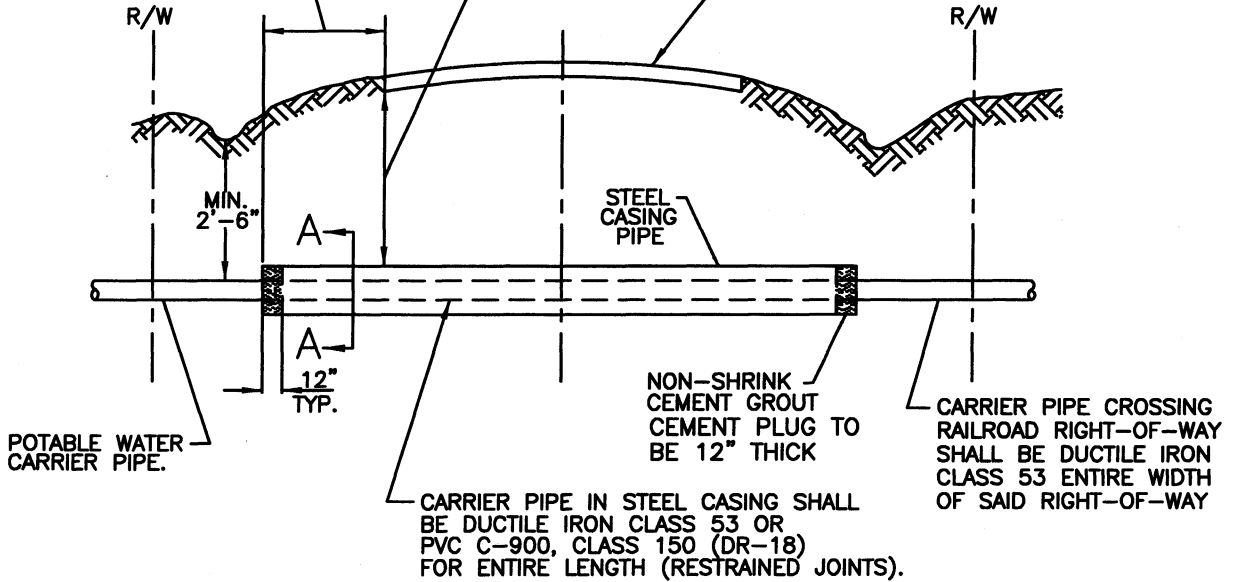

12" THICK PLUG SHALL BE MADE BY GROUTING ANNULAR SPACE BETWEEN CARRIER PIPE & CASING W/ NON SHRINKING CEMENT GROUT.

NOTE: PRESSURE TREATED WOOD OR STEEL SUPPORT BLOCKS STRAPPED TO CARRIER PIPE OR 304 STAINLESS STEEL BAND CASING INSULATORS AS MANUFACTURED BY ADVANCE PRODUCTS & SYSTEMS INC., PIPELINE SEAL & INSULATOR INC. OR APPROVED EQUAL PLASTIC (HDPE) SPACERS AS MANUFACTURED BY RACI OR APPROVED EQUAL MAY BE USED ON CARRIER PIPE UP TO 12" DIAMETER.

SECTION A-A

MANATEE COUNTY  
PUBLIC WORKS DEPARTMENT

CARRIER & CASING DETAIL  
FOR F.D.O.T. ROADS &  
RAILROAD CROSSINGS

UW-7

REV. BY	DATE
RTH	11/99

MARCH 18, 1997  
DATE OF APPROVAL

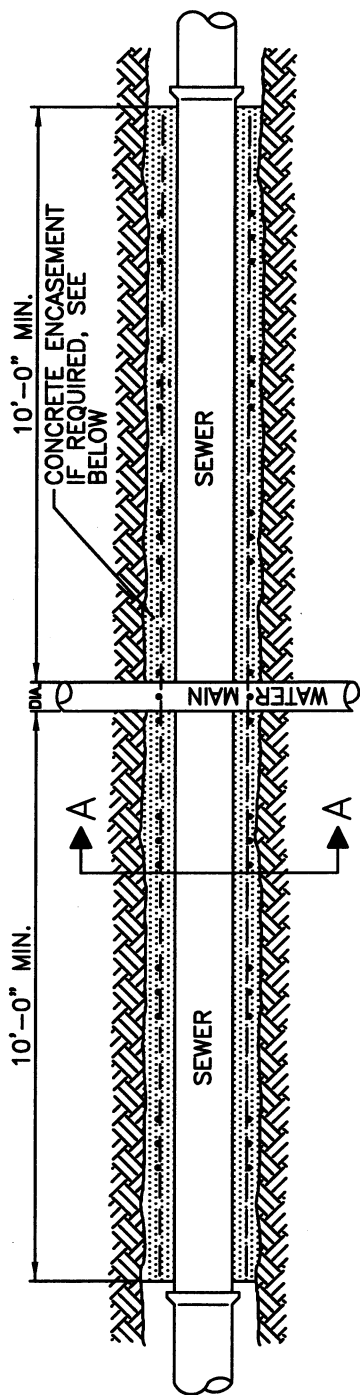

PLAN VIEW

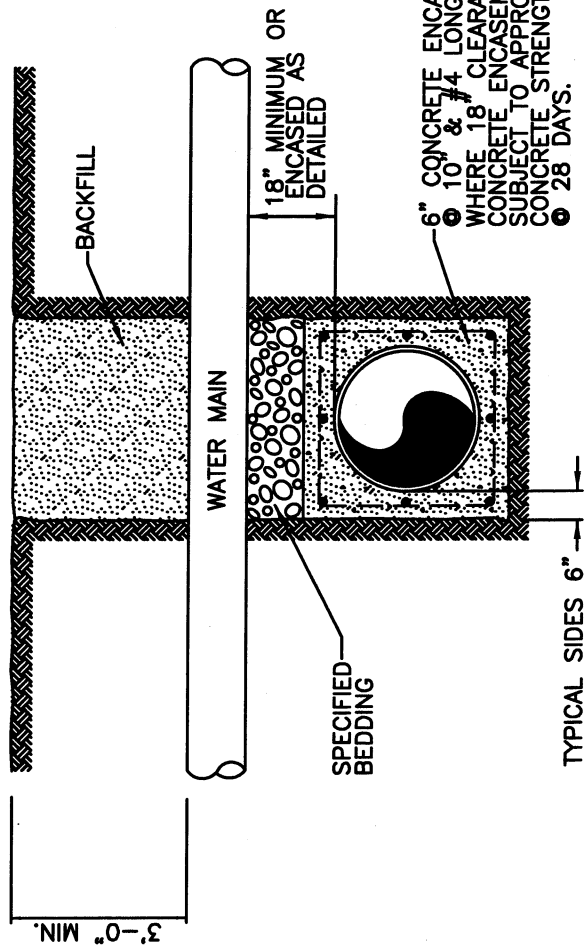

SECTION A-A

MANATEE COUNTY  
PUBLIC WORKS DEPARTMENT

REV. BY	DATE

MARCH 18, 1997  
DATE OF APPROVAL

TYPICAL WATER/  
SEWER CROSSING

UW-8

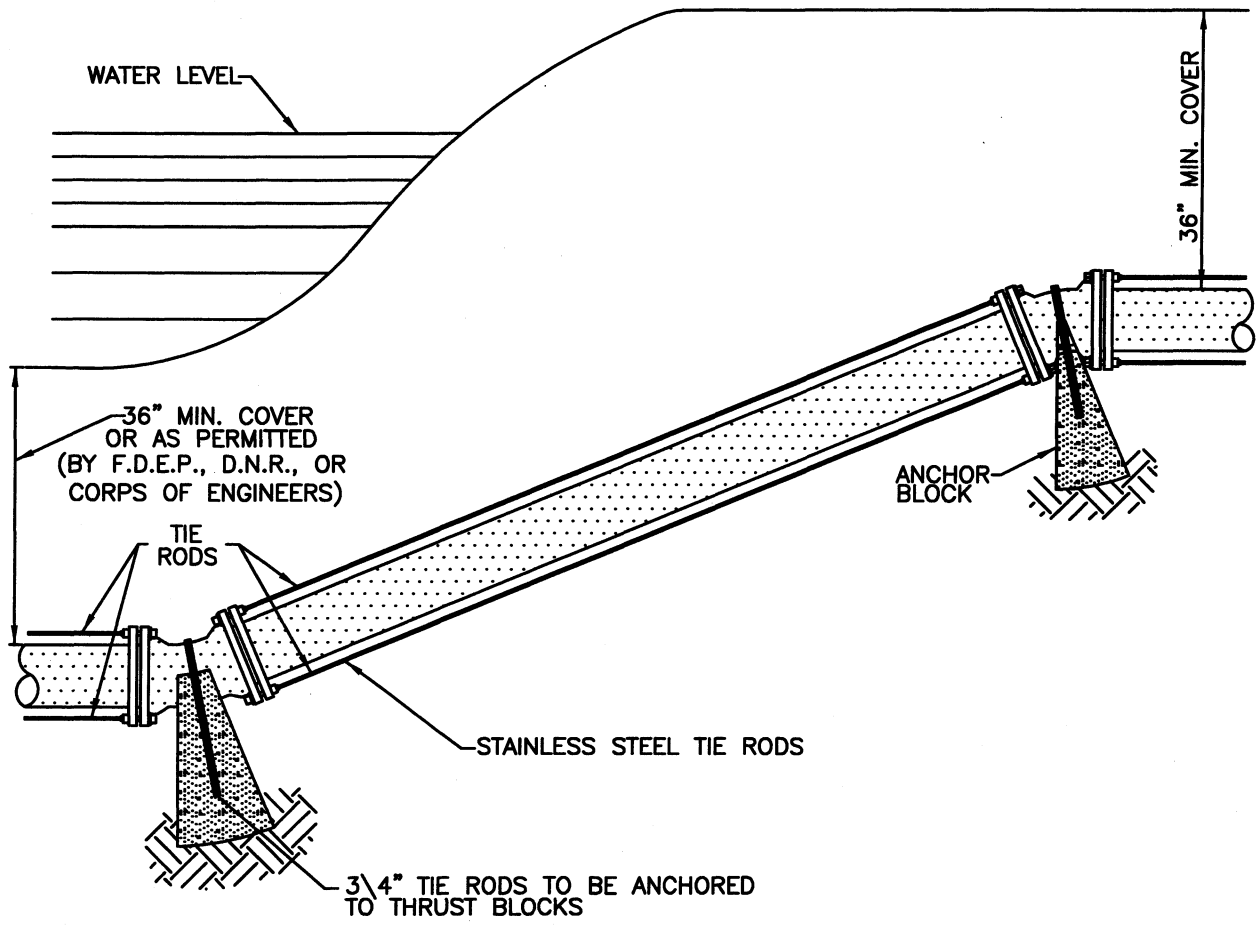

- NOTE: 1. RESTRAINED JOINT PIPE & FITTINGS MAY BE USED IN LIEU OF TIE-RODS & BLOCKS, J.C.M., M.J.R., "STAR GRIP", "ALL GRIP" OR APPROVED EQUAL. SUBMIT DETAILS TO MCPWD, ENGINEERING DIVISION FOR APPROVAL.
2. SEE UW-14 FOR THRUST BLOCK DETAILS.
3. ENGINEER TO DETERMINE REQUIRED LENGTH OF RESTRAINT EACH SIDE OF BEND.

MANATEE COUNTY PUBLIC WORKS DEPARTMENT		TYPICAL CANAL CROSSING	UW-9
REV.BY RTH	DATE 11/99		
MARCH 18, 1997 DATE OF APPROVAL			