

# MANATEE COUNTY GOVERNMENT

## INVITATION FOR BIDS (IFB) #09-0485CD

### PURCHASE OF SPORTS LIGHTING SYSTEMS FOR VARIOUS PARK'S SOCCER FIELDS

Manatee County, a political subdivision of the State of Florida, (hereinafter "Manatee County" or the "County") will receive sealed bids from individuals, corporations, partnerships, and other legal entities organized under the laws of the State of Florida or authorized to conduct business in the State of Florida.

INFORMATION CONFERENCE: In order to insure that all prospective bidders have sufficient information and understanding of the County's needs, an information conference will be held:

**Thursday, January 15, 2009 at 1:00 PM**

at the Manatee County Administrative Center, Purchasing Division, 1112 Manatee Avenue West, Suite 803, Bradenton, Florida 34205. Site visits will be conducted immediately following the informational conference. All interested bidders are encouraged to attend. THE INFORMATION CONFERENCE IS **NOT** A MANDATORY MEETING.

TIME AND DATE DUE: **Monday, January 26, 2009 at 1:00 PM**

#### CONTENTS OF THIS INVITATION FOR BIDS:

A.	Information to Bidders	Pages 2 - 8
B.	General Terms & Conditions	Pages 9 - 10
C.	Specific Terms & Conditions	Pages 11 - 13
D.	Specifications	Pages 14 - 18
E.	Basis of Award	Pages 19
F.	Bid Form	Page 20
	Statement of No Bid	Attachment A
	Drug Free Work Place Form	Attachment B
	Public Contracting and Environmental Crime Form	Attachment C
	Site Layout Plans	3 Pages
	Manatee County Outdoor Lighting Regulations	13 Pages

**Important Note:** A prohibition of Lobbying has been enacted. Please review paragraph A.20 carefully to avoid violation and possible sanctions.

**FOR INFORMATION CONTACT:**

**CHRIS DALEY, CPPB- SENIOR BUYER**

Phone (941) 749-3048 - Fax (941) 749-3034

AUTHORIZED TO RELEASE: 

## INFORMATION TO BIDDERS

### A.01 OPENING LOCATION

These bids will be publicly opened in the Manatee County Purchasing Office, 1112 Manatee Avenue West, Suite 803, Bradenton, Florida 34205 in the presence of County officials at the time and date stated. All bidders or their representatives are invited to be present.

### A.02 BID INFORMATION AND BID DOCUMENTS

Manatee County Purchasing Division posts **notices of bid or proposal opportunities and addenda** on the Purchasing Division's web page at <http://www.mymanatee.org> which can be accessed by clicking on the "Purchasing" button on the left side of the screen and then clicking on the "Bids and Proposals" button and **on the County's document distribution service** at <http://www.demandstar.com>.

Electronic copies of Bid or Proposal documents may be requested at no cost per Florida Statute 119.01 (2) (e). These files in PDF format may be obtained by calling the person or persons identified to contact on page one.

A fee may be charged for creating a CD recording or a printed copy of the documents requested. Cost Details shall be provided when you specify the format.

The **documents are available in a portable document format (.PDF) files** which you may view and print using Adobe Acrobat software. You may download a free copy of this software (Adobe) from the County's web page if you do not have it.

Onvia **DemandStar** provides direct electronic distribution of email/fax notices of the agency's formal bid or proposal opportunities, at no charge. The distribution lists provided by this service are supplemented by the County.

Vendors may choose to download individual documents from DemandStar for a download fee posted on that services website. Vendors may contact DemandStar regarding an agency level subscription option that allows vendors to download bid documents and transact business with any one (1) agency for free. If a vendor chooses to increase the number of agencies beyond their single agency, subscription fees based on the level of service chosen will apply.

Documents may be purchased from Onvia DemandStar. The cost for copies of documents purchased from Onvia DemandStar is established per document and the cost information is published as part of the specific Proposal detail, subsection "Pre Bid Conference" on the Onvia DemandStar web pages.

**Award Document/Recommendations** appear on the Onvia DemandStar web page.

**Notices of Source Selections** appear on the Onvia DemandStar web page and the County's web page (Financial Management – Purchasing Division).



## A.02 BID INFORMATION AND BID DOCUMENTS (Continued)

Onvia DemandStar may be directly contacted at <http://demandstar.com> or by calling 800-331-5537, if you have any questions.

**IMPORTANT NOTE:** AUTOMATED NOTICES OF ADDENDA ARE ISSUED ONLY VIA THE ONVIA DEMANDSTAR "PLANHOLDER" DISTRIBUTION SYSTEM

IF YOU OBTAIN A COPY OF THIS BID OR PROPOSAL DOCUMENT FROM OTHER THAN REGISTERING WITH ONVIA DEMANDSTAR WEB SERVICE FOR THIS SPECIFIC PROPOSAL – YOU SHALL NOT RECEIVE AUTOMATED NOTIFICATIONS OF ADDENDA.

IT IS THE RESPONSIBILITY OF EACH BIDDER OR PROPOSER, PRIOR TO SUBMITTING THEIR BID OR PROPOSAL, TO CONTACT THE MANATEE COUNTY PURCHASING OFFICE (see contact information on page one) TO DETERMINE IF ADDENDA WERE ISSUED AND TO MAKE SUCH ADDENDA A PART OF THEIR BID OR PROPOSAL.

Please contact the individual named on the first page of this bid or proposal document, if you have questions on this instruction.

## A.03 BID FORM DELIVERY REQUIREMENTS

Any bids received after the stated time and date will not be considered. It shall be the sole responsibility of the bidder to have their bid delivered to the Manatee County Purchasing Office for receipt on or before the stated time and date. If a bid is sent by U.S. Mail, the bidder shall be responsible for its timely delivery to the Purchasing Office. Bids delayed by mail shall not be considered, shall not be opened at the public opening, and arrangements shall be made for their return at the bidder's request and expense.

## A.04 CLARIFICATION & ADDENDA

Each bidder shall examine all Invitation for Bids documents and shall judge all matters relating to the adequacy and accuracy of such documents. Any inquiries, suggestions or requests concerning interpretation, clarification or additional information pertaining to the Invitation for Bids shall be made through the Manatee County Purchasing Office. The County shall not be responsible for oral interpretations given by any County employee, representative, or others. The issuance of a written addendum is the only official method whereby interpretation, clarification or additional information can be given.

**If any addenda are issued to this Invitation for Bids, the County will BROADCAST THE ADDENDA ON ONVIA DEMANDSTAR TO "PLANHOLDERS" IDENTIFIED ON THIS WEB SERVICE**, however, it shall be the responsibility of each bidder, prior to submitting their bid, to contact the Manatee County Purchasing Office (see contact information on page 1) to determine if addenda were issued and to make such addenda a part of their bid.

A.05 SEALED & MARKED

Three signed copies of your bid shall be submitted in one sealed package, clearly marked on the outside "Sealed Bid #09-0485CD – Purchase of Sports Lighting Systems for Various Park's Soccer Fields" with your company name. Address package to:

Manatee County Purchasing Office  
1112 Manatee Avenue West, Suite 803  
Bradenton, Florida 34205

A.06 LEGAL NAME

Bids shall clearly indicate the legal name, address and telephone number of the bidder. Bids shall be signed above the typed or printed name and title of the signer. The signer must have the authority to bind the bidder to the submitted bid.

A.07 BID EXPENSES

All expenses for making bids to the County are to be borne by the bidder.

A.08 IRREVOCABLE OFFER

Any bid may be withdrawn up until the date and time set for opening of the bid. Any bid not so withdrawn shall, upon opening, constitute an irrevocable offer for a period of 90 days to sell to Manatee County the goods or services set forth in the attached specifications until one or more of the bids have been duly accepted by the County.

A.09 RESERVED RIGHTS

The County reserves the right to accept or reject any and/or all bids, to waive irregularities and technicalities, and to request resubmission. Also, the County reserves the right to accept all or any part of the bid and to increase or decrease quantities to meet additional or reduced requirements of the County. Any sole response received by the first submission date may or may not be rejected by the County depending on available competition and current needs of the County. For each item or for all items combined, the bid of the lowest responsive, responsible bidder will be accepted, unless all bids are rejected. The lowest responsive bidder shall mean that bidder who makes the lowest bid to sell goods and/or services of a quality which conforms closest to or most exceeds the quality of goods and/or services set forth in the attached specifications or otherwise required by the County, and who is fit and capable to perform the bid as made.

To be responsive, a bidder shall submit a bid which conforms in all material respects to the requirements set forth in the Invitation for Bids. To be a responsible bidder, the bidder shall have the capability in all respects to perform fully the contract requirements, and the tenacity, perseverance, experience, integrity, reliability, capacity, facilities, equipment, and credit which will assure good faith performance. Also, the County reserves the right to make such investigation as it deems necessary to determine the ability of any bidder to deliver the goods or service requested. Information the County deems necessary to make this determination shall be provided by the bidder. Such information may include, but shall not be limited to: current financial statements, verification of availability of equipment and personnel, and past performance records.



#### A.10 APPLICABLE LAWS

Bidder must be authorized to transact business in the State of Florida. All applicable laws and regulations of the State of Florida and ordinances and regulations of Manatee County will apply to any resulting agreement. Any involvement with any Manatee County procurement shall be in accordance with Manatee County Purchasing Code Ordinance 08-43, as amended. Any actual or prospective Bidder who is aggrieved in connection with the solicitation or award of a contract may protest to the Board of County Commissioners of Manatee County as required in Section 2-26/61 of the Purchasing Code.

A protest with respect to this Invitation For Bid shall be submitted in writing prior to the scheduled opening date of this proposal, unless the aggrieved person did not know and could not have been reasonably expected to have knowledge of the facts giving rise to such protest prior to the scheduled opening date of this proposal. The protest shall be submitted within seven calendar days after such aggrieved person knows or could have reasonably been expected to know of the facts giving rise thereto.

#### A.11 CODE OF ETHICS

With respect to this bid, if any Bidder violates or is a party to a violation of the Code of Ethics of Manatee County per Manatee County Purchasing Code Ordinance 08-43, Article 3, Ethics in Public Contracting, and/or the state of Florida per Florida Statutes, Chapter 112, Part III, Code of Ethics for Public Officers and Employees, such Bidder may be disqualified from performing the work described in this bid or from furnishing the goods or services for which the bid is submitted and shall be further disqualified from submitting any future bids or proposals for work or for goods or services for Manatee County.

The County anticipates that all statements made and materials submitted in a bid will be truthful. If a bidder is determined to be untruthful in its bid or any related presentation, such bidder may be disqualified from further consideration regarding this Invitation For Bid.

#### A.12 COLLUSION

By offering a submission to this Invitation for Bids, the bidder certifies that the bidder has not divulged, discussed or compared their bid with other bidders, and has not colluded with any other bidder or parties to this bid whatsoever. Also, bidder certifies, and in the case of a joint bid each party thereto certifies as to their own organization, that in connection with this bid:

- a. any prices and/or cost data submitted have been arrived at independently, without consultation, communication, or agreement, for the purpose of restricting competition, as to any matter relating to such prices and/or cost data, with any other bidder or with any competitor;
- b. any prices and/or cost data quoted for this bid have not been knowingly disclosed by the bidder and will not knowingly be disclosed by the bidder, prior to the scheduled opening, directly or indirectly to any other bidder or to any competitor;
- c. no attempt has been made or will be made by the bidder to induce any other person or firm to submit or not to submit a bid for the purpose of restricting competition;

A.12 COLLUSION (Continued)

- d. the only person or persons interested in this bid, principal or principals is/are named therein and that no person other than therein mentioned has any interest in this bid or in the contract to be entered into; and
- e. no person or agency has been employed or retained to solicit or secure this contract upon an agreement or understanding or a commission, percentage, brokerage, or contingent fee excepting bona fide employees or established commercial agencies maintained by bidder for purpose of doing business.

A.13 BID FORMS

Bids must be submitted on attached County forms, although additional pages may be attached. **Bidders must fully comply with all bid specifications, terms and conditions.** Failure to comply shall result in contract default, whereupon, the defaulting vendor shall be required to pay for any and all re-procurement costs, damages, and attorney fees as incurred by the County.

A.14 DISCOUNTS

Any and all discounts must be incorporated in the prices contained in the bid; and not shown separately. The prices as shown on the bid form shall be the price used in determining award(s).

A.15 TAXES

Manatee County is exempt from Federal Excise and State Sales Taxes. (F.E.T. Exempt Cert. No. 59-78-0089K; FL Sales Tax Exempt Cert. No. **51-02-027548-53C**); therefore, the vendor is prohibited from delineating a separate line item in his bid for any sales or service taxes. Nothing herein shall affect the vendor's normal tax liability.

A.16 MATHEMATICAL ERRORS

In the event of multiplication/extension error(s), the unit price shall prevail. In the event of addition error(s) the extension totals will prevail. All bids shall be reviewed mathematically and corrected, if necessary, using these standards, prior to additional evaluation.

A.17 DESCRIPTIVE INFORMATION

Unless otherwise specifically provided in the specifications, all equipment, materials and articles incorporated in the work covered by this contract shall be new and of the most suitable grade for the purpose intended. Unless otherwise specifically provided in the specifications, reference to any equipment, material, article or patented process, by trade name, brand name, make or catalog number, shall be regarded as establishing a standard of quality and shall not be construed as limiting competition.



#### A.18 MODIFICATION OF BID SPECIFICATIONS

If a bidder wishes to recommend changes to the bid specifications, the bidder shall furnish in writing, data and information necessary to aid the County in evaluating the request to modify the bid specifications. The County is not obligated to make any changes to the bid specifications. Unless an addendum is issued as outlined in paragraph A.04, six calendar days prior to the opening date of this bid, the bid specifications shall remain unaltered. **Bidders must fully comply with the bid specifications, terms, and conditions.**

#### A.19 AMERICANS WITH DISABILITIES ACT

The Board of County Commissioners of Manatee County, Florida, does not discriminate upon the basis of any individual's disability status. This non-discrimination policy involves every aspect of the County's functions including one's access to, participation, employment, or treatment in its programs or activities. Anyone requiring reasonable accommodation for an **Information Conference** or **Bid Opening**, should contact the person named on the first page of this Bid document at least twenty four (24) hours in advance of either activity.

#### A.20 LOBBYING

After the issuance of any Request for Proposals or Invitation for Bids, prospective bidders, proposers or any agent, representative or person acting at the request of such bidder or proposer shall not contact, communicate with or discuss any matter relating in any way to the Request for Proposals or Invitation for Bids with any officer, agent or employee of Manatee County other than the Purchasing Director or as directed in the Request for Proposals or Invitation for Bids. This prohibition begins with the issuance of any Request for Proposals or Invitation for Bids, and ends upon execution of the final contract or when the invitation or request has been canceled. Violators of this prohibition shall be subject to sanctions as provided in the Manatee County Purchasing code.

The County reserves the right to amend or to add to the names listed as persons to contact. All amendments or additions to the names listed as persons to contact shall be issued by the Purchasing Office, in writing.

#### A.21 DRUG FREE WORK PLACE

The Manatee County Board of County Commissioners adopted a policy regarding Bidders maintaining a Drug Free Work Place, prohibiting the award of bids to any person or entity that has not submitted written certification to the County that it has complied with those requirements [Reference Resolution R-93-22, Manatee County Purchasing Policies, Section 4, E (1) (a)]. A Drug Free Work Place Certification Form is attached to this bid for this purpose.

#### A.22 PUBLIC ENTITY CRIMES

In accordance with Section 287.133, Florida Statutes, a person or affiliate who has been placed on the convicted vendor list following a conviction for a public entity crime may not submit a bid on a contract to provide any goods or services to a public entity, may not submit a bid on a contract with a public entity for the construction or repair of a public building or public work, may not submit bids on leases or real property to a public entity, may not be awarded or perform work as a contractor, supplier, subcontractor, or consultant under a contract with any public entity, and may not transact business with any public entity in excess of the threshold amount provided in Section 287.017 for Category Two (as of 1/01/2005 is \$25,000) for a period of 36 months from the date of being placed on the convicted vendor list.

#### A.23 PUBLIC CONTRACTING AND ENVIRONMENTAL CRIMES CERTIFICATION

In accordance with Ordinance 08-43, adding Article 5, Manatee County Board of County Commissioners adopted a policy prohibiting the award of County contracts to persons, business entities, or affiliates of business entities who have not submitted written certification to the County that they have not been convicted of bribery, attempted bribery, collusion, restraints of trade, price fixing, and violations of certain environmental laws. A Non-Conviction Certification Form is attached for this purpose.

#### A.24 EQUAL EMPLOYMENT OPPORTUNITY CLAUSE

Manatee County, in accordance with the provisions of Title VI of the Civil Rights Act of 1964 and the Regulations of the Department of Commerce (15 CFR, Part 8) issued pursuant to such Act, hereby notifies all vendors that it will affirmatively ensure that in any contract entered into pursuant to this advertisement, minority business enterprises will be afforded full opportunity to submit bids in response to this advertisement and will not be discriminated against on the grounds of race, color or national origin in consideration for an award.

**NOTE: ANY OR ALL STATEMENTS CONTAINED IN THE FOLLOWING SECTIONS: GENERAL TERMS AND CONDITIONS, SPECIFIC TERMS AND CONDITIONS, SPECIFICATIONS OR BASIS OF AWARD, WHICH VARY FROM THE INFORMATION TO BIDDERS SHALL HAVE PRECEDENCE**



## GENERAL TERMS AND CONDITIONS

### B.01 CONTRACT FORMS

Any agreement, contract, or Purchase Order resulting from the acceptance of a bid shall be made by a purchase order and be bound by the terms and conditions herein.

### B.02 AUTHORIZED PRODUCT REPRESENTATION

The vendor, by virtue of submitting the name and specifications of a manufacturer's product, will be required to furnish the named manufacturer's product. The vendor's failure to perform accordingly may, in the County's sole discretion, be deemed a breach of contract, and shall constitute grounds for the County's immediate termination of the contract.

### B.03 QUALITY GUARANTEE

If any product/service delivered does not meet performance representations or other quality assurance representations as published by manufacturers, producers or distributors of such products or the specifications listed in this bid, the vendor shall pick up the product from the County at no expense to the County. The County reserves the right to reject any or all materials if, in its judgment, the item reflects unsatisfactory workmanship or manufacturing or shipping damage. Also, the vendor shall refund to Manatee County any money which has been paid for same. The vendor will be responsible for attorney fees in the event the supplier defaults and court action is required.

### B.04 ROYALTIES AND PATENTS

The vendor shall pay all royalties and license fees for equipment or processes in conjunction with the equipment and/or services he is furnishing. Vendor shall defend all suits or claims for infringement of any patent, trademark or copyright, and shall save the County harmless from loss on account thereof, including costs and attorney's fees.

### B.05 INDEMNIFICATION

The successful vendor covenants and agrees to indemnify and save harmless the County, its agents and employees, from and against all claims, suits, actions, damages, causes of action, or judgments arising out of the terms of the resulting agreement for any personal injury, loss of life, or damage to the property sustained as a result of the performance or non-performance of services or delivery of goods; from and against any orders, judgments, or decrees, which may be entered against the County, its agents or employees; and from and against all costs, attorney's fees, expenses and other liabilities incurred in the defense of any such claim, suit or action, and the investigation thereof. Nothing in the award, resulting agreement, contract or Purchase Order shall be deemed to affect the rights, privileges and immunities of the County as set forth in Florida Statute Section 768.28.

**B.06 REGULATIONS**

It shall be the responsibility of the bidder to assure compliance with any OSHA, EPA and/or other Federal or State of Florida rules, regulations or other requirements, as each may apply.

**B.07 MANUALS, SCHEMATICS, HANDBOOKS**

All manuals, schematics and handbooks shall be provided which are applicable to the equipment delivered. An operators manual, parts manual and technician manual must also be provided. Parts lists (manuals) must include OEM part numbers for items not manufactured by the bidder. Vendor shall furnish two (2) copies of each publication.



## SPECIFIC TERMS & CONDITIONS

### C.01 PURPOSE

It is the intent of the County of Manatee to purchase Sports Lighting Systems, for installation by others at the Buffalo Creek, Braden River, and Lakewood Ranch Park's soccer fields, in accordance with the specifications listed herein.

### C.02 QUANTITIES

The quantity to be purchased is listed on the bid form.

### C.03 DELIVERY TIME

Delivery by the vendor shall be made within forty five (45) days of receipt of a Notice to Proceed from the County. All deliveries shall be made between the hours of 8:00 A.M. and 3:00 P.M., Monday through Friday, excluding holidays, to the predesignated location agreed to by the County's representative. Large shipments, i.e., truckloads requiring material handling equipment, must be preceded by no less than 24 hours notice.

Vendor shall provide a separate delivery ticket for each delivery and will obtain authorized signatures from buyer's employee. At least one copy of the delivery ticket shall be left with employee on each delivery.

### C.04 LIQUIDATED DAMAGES

If the Vendor refuses or fails to deliver the Systems, or any separable part thereof, with such diligence as will hinder its completion within the time specified, the County may seek damages. The actual damages for delay will be impossible to determine and in lieu thereof, the Vendor shall pay to the County the sum of **\$544** as fixed, agreed, and liquidated damages for each calendar day of the delay until the Systems are finally accepted by the County and the Vendor shall be liable for the amount thereof.

### C.05 PRICES & TERM

Bidders shall bid unit prices, F.O.B. Destination, including all discounts in accordance with unit of quantity indicated on Bid Form. The prices bid shall be used for payment and shall be deemed to include payment in full for all transportation, labor, equipment, and lighting plans used in delivering all supplies and materials to the point of delivery.

### C.06 PAYMENT

Within forty-five (45) days after delivery by the vendor, acceptance by the County, and presentation of an appropriate invoice, the County shall pay the total amount due. Payment invoices must indicate both the Blanket Purchase Order number and the Release Order number.

C.07 CANCELLATION

Upon any failure of the vendor to furnish or perform the Work (including, but not limited to, commencement of the Work, failure to supply sufficient skilled workers or suitable materials or equipment) in accordance with the contract, the County may order the stop of the Work, or any portion thereof, until the cause for such order has been eliminated. If the vendor persistently fails to perform the Work in accordance with the contract, the County reserves the right to terminate the contract and select the next qualified bidder or readvertise this procurement in part or in whole. The County reserves the right to cancel all or any undelivered or unexecuted portion of this contract with or without cause.

C.08 WARRANTY, MAINTENANCE SERVICE AND SUPPORT

If any product/service delivered does not meet performance representations or other quality assurance representations as published by manufacturers, producers or distributors of such products or the specifications listed in this bid, the vendor shall pick up the product from the County at no expense to the County. Also, the vendor shall refund to Manatee County any money which has been paid for same. The vendor will be responsible for attorney fees in the event the supplier defaults and court action is required.

C.09 INSURANCE

The vendor will not commence work under a contract until the vendor has obtained all insurance under this section and such insurance coverage as might be required by the County. The vendor shall obtain, at his expense, the following minimum amounts of insurance (inclusive of any amounts provided by an umbrella or excess policy):

a. Commercial General Liability

The limits are to be applicable only to work performed under this contract and shall be those that would be provided with the attachment of the Amendment of Limits of Insurance (Designated Project or Premises) endorsement (ISO Form CG 25 03) to a Commercial General Liability Policy with the following minimum limits.

Products/Completed Operations Aggregate	<u>\$300,000</u>
Personal and Advertising Injury	<u>\$300,000</u>
Each Occurrence	<u>\$300,000</u>
Fire Damage (Any One Fire)	\$ Nil
Medical Expense (Any One Person)	\$ Nil

b. Business Auto Policy

Each Occurrence Bodily Injury and Property Damage Liability Combined \$300,000  
Annual Aggregate (If Applicable) Three Times Each Occurrence Limit.

c. Owners Protective Liability Coverage

The minimum OCP Policy limits per occurrence and, if subject to an aggregate, annual aggregate to be provided by the bidder shall be the same as the amounts shown above as the minimum per occurrence and general policy aggregate limits respectively required for the Commercial General Liability coverage. The limits afforded by the OCP Policy and any excess policies shall apply only to the Owner and the Owner's officials, officers, agents and employees and only to claims arising out of or in connection with the work under this contract.



C.09 INSURANCE (Continued)d. Certificates of Insurance and Copies of Policies

Certificates of Insurance in triplicate evidencing the insurance coverage specified in the above paragraphs shall be filed with the Purchasing Director before operations are begun. The required certificates of insurance shall name the types of policy, policy number, date of expiration, amount of coverage, companies affording coverage, and also shall refer specifically to the bid number, project title and location of project. Insurance shall remain in force at least one year after completion and acceptance of the project by the County, in the amounts and types as stated herein, including coverage for all products and services completed under this contract.

**ADDITIONAL INSURED: - The successful vendor shall name Manatee County as additional insured in items b. and d. of the required policies.**

If the initial insurance expires prior to the completion of operations and/or services by the vendor, renewal certificates of insurance and required copies of policies shall be furnished by the vendor and delivered to the Purchasing Director thirty (30) days prior to the date of their expiration.

Nothing herein shall in any manner create any liability of the County in connection with any claim against the vendor for labor, services, or materials, or of subcontractors; and nothing herein shall limit the liability of the vendor or his sureties to the County or to any workers, suppliers, materialmen or employees.

C.10 MATERIAL/SAFETY DATA SHEET

It shall be the responsibility of the awarded bidder(s) to submit, upon notification of award, a Material Safety Data Sheet (MSDS) for all toxic substances in accordance with Florida Statutes Chapter 442, The Right To Know Law, which mandates on-site MSDS for all toxic substances appearing in the work place.

## TECHNICAL SPECIFICATIONS

### D.01 THE WORK

The Work described herein shall include the furnishing of all materials, labor, and equipment to supply and deliver a new sports lighting system for one (1) soccer field at the Buffalo Creek Park Complex, one (1) soccer field at the Braden River Park Complex, and two (2) soccer fields at the Lakewood Ranch Park Complex per the following specifications:

#### **A. SPECIFICATIONS FOR NEW SPORTS LIGHTING SYSTEMS**

The purpose of this specification is to define the performance and design standards for the sports field lighting equipment. The vendor shall supply lighting equipment to meet or exceed the following criteria.

##### **1. LIGHTING PERFORMANCE/PLAYABILITY**

The minimum lighting performance standards for the fields have been established as described in **Figure 1** below.

**Figure 1**

FIELD LOCATION AND DESCRIPTION	MIN. AVG. MAINTAINED FOOTCANDLE	Uniformity Max / Min Ratio	Coefficient of Variation (CV)	Off Field Light Criteria (Boundary)
<b>Buffalo Creek Park- (1) Soccer/Football-</b> Design criteria is a 180 ft x 360 ft soccer/football field, 30 FC design, 4- poles (70 ft min height) in a universal layout (four corners design) setbacks are to be field determined.	30	3:1 (or less)	0.25 (or less)	<b>East-</b> Show Spill at 100 ft ; <b>North-</b> Show spill light at 100 ft
<b>Braden River Park- (1) Soccer Field #3-</b> Design criteria is a 180 ft x 360 ft soccer field, 30 FC design, 4- poles (70 ft min height)-setbacks are to be field determined	30	3:1 (or less)	0.25 (or less)	<b>South-</b> Show spill light at 50 ft (ROW) and 100 ft. <b>East-</b> Show spill light at 75 ft.
<b>Lakewood Ranch Park- (2) Soccer Fields-</b> Design criteria are two (2) soccer fields at 220 ft x 360 ft aligned north and south, 30 FC design, 6- poles (70 ft min height) in a universal layout (four corners design) with the fields sharing two poles-setbacks are to be field determined.	30	3:1 (or less)	0.25 (or less)	<b>North Field-</b> Show spill light at 100 ft (north of field) and 100 ft to the west. <b>South Field-</b> Show spill light at 100 ft to the east, 100 ft to the west, and 50 ft to the south.



## 1. LIGHTING PERFORMANCE/PLAYABILITY (Continued)

- a. **Quantity:** Since there are many varying technologies and design approaches in the sports lighting industry today, each vendor will be required to submit their formulas for the design calculations used to arrive at the maintained values in **Figure 1**. Each vendor shall be required to show their initial and maintained lighting values. There shall be a minimum average of maintained horizontal footcandles on the playing surface for the facilities listed above in **Figure 1** for a minimum of 3000 hours. **At no time during the 3000 hours usage is the horizontal footcandles allowed to drop below the maintained minimum average.**
- b. **Quality:** The quality of the lighting system shall be determined on a basis of uniformity and smoothness. The lighting measurements shall be taken on a 30ft by 30ft grid over the entire field. The criteria for the uniformity and smoothness of the lighting system are defined as follows:
  - 1) **Uniformity:** The uniformity shall be such that the highest measure of quantity of light shall not be greater than the lowest quantity per ratios in **Figure 1**.
  - 2) **Smoothness:** Over the entire area of the fields described in **Figure 1**, the change in the quantity of horizontal footcandles shall not occur at a rate greater than +/- 10% per grid point.
  - 3) **Lamps:** The lamps shall be 1500 watt metal halide.

## B. ENVIRONMENTAL LIGHT CONTROL

The lighting system must conform to the Outdoor Lighting Regulations from the Manatee County Land Development Code Ordinance 05-37; a copy of which is attached to this bid. All lighting fixtures shall have full oblique shielding so that the lighting systems do not directly illuminate another property that has an outdoor lighting protected area. The total illumination caused by the lighting systems for any configuration shall not illuminate (spill onto) another property in excess of the following limits:

1. 0.2 foot-candles on property with outdoor lighting protected areas but not including the street rights-of-way.
2. 1.5 foot-candles on street rights-of-way.

## C. REMOTE MONITORING AND CONTROL

The lighting system shall have technology that allows for flexible control and facility management of the lighting system. This technology shall include, but not limited to, automatic timers and controllers as required by the Outdoor Lighting Regulations from the Manatee County land Development Code Ordinance 05-37, and shall be included in the cost of the lighting system(s). All systems shall have an hour meter, at least one per field, and shall be included in the cost of the lighting system(s).

**C. REMOTE MONITORING AND CONTROL (Continued)**

The lighting systems shall also have the capability of remote switching and control. Vendors shall submit literature from the lighting system's manufacture about this technology with their bid, including specific operating procedures. The price for this feature shall be included in the equipment price.

**D. LIGHTING SYSTEM CONSTRUCTION**

The pole shaft may either be galvanized with a concrete foundation, or spun prestressed concrete for direct burial. The pole shaft and all attachments of the lighting system shall comply with the Florida Building Code Edition 2004 by withstanding winds of up to 130 mph with an importance factor of 1.0 exposure B. The luminaire assembly, including crossarms, shall withstand the maximum wind speed above and still maintain proper alignment. All poles shall have the ability to be used as common or shared poles.

The vendor shall supply an electrical component enclosure (ECE) that is either aluminum or stainless steel and UL or NEMA 4 rated. The ECE shall house and include the ballast, capacitors and fusing for each luminaire as well as the safety disconnect switch. The ECE shall be mounted onto the pole shaft approximately ten (10) feet above grade.

All exposed components of the lighting system shall be constructed of corrosion resistant material and/or coated to help prevent corrosion. All exposed steel shall be hot dipped galvanized per ASTM 123. All exposed aluminum shall be powder coated with high performance polyester. All wiring shall be enclosed within the crossarms, pole, or ECE.

All lighting system structures shall be equipped with lightning protection meeting NFPA 780 standards. All system components shall be UL listed for the appropriate application.

All components shall be designed and manufactured as a system. All luminaires, wire harnesses, ballast and other enclosures shall be factory assembled, aimed, wired and tested.

The successful vendor shall supply a signed and sealed engineering drawing for the foundation designs showing the foundation shape, depth backfill requirements, rebar and anchor bolts (if required). Pole base reaction forces shall be shown on the foundation drawing along with soil bearing pressures.

The typical Florida soil can achieve a bearing capacity of 2000 psf. However, there may be instances where the bearing capacity could be lower. Therefore, all foundation designs for this order shall be based on soils that meet or exceed those of a Class 5 material, as defined by the 2004 Florida Building Code Table 1804.2.



D.02 WARRANTY AND GUARANTEE

The successful quoter shall furnish a manufacturer's warranty on all equipment furnished hereunder against defect in material and/or workmanship for a minimum of twenty five (25) years. The manufacturer shall provide spot (individual) lamp changes when the lamp outages materially affect the usage and/or play on the field. The manufacturer shall warranty that the light levels shall not fall below the maintained minimum average during 3000 hours of use, and each subsequent lamp change for 3000 hours of use, over a minimum of twenty five (25) years. Warranty may exclude major storm damage, vandalism, failure of owner's electrical service, and unauthorized repairs or alterations. The manufacturer's warranty shall become effective on the date of delivery and acceptance by the County.

The successful bidder shall perform, at a minimum, a light level test after the initial 100 hour burn-in period for each lamp change. The light level test shall be conducted by a trained manufacturer's representative with a calibrated light meter accompanied by a representative of Manatee County. If at anytime during 3000 hours of use (of any lamp change over 25 years), Manatee County feels that the light levels have fallen below the maintained minimum average, the manufacture shall perform a light level test. If the light level is below the maintained minimum average, then the manufacturer shall correct the problem at the manufacturer's full expense.

If the test reveals that the system is at or above the maintained minimum average, Manatee County shall pay for the light level test.

The following table will serve as further clarification of the warranty, and the responsibility of each party:

DESCRIPTION OF SITUATION	RESPONSIBLE PARTY
Individual lamp outages that materially affect the usage and/or play on the field, during 3000 hours of use	Manufacturer- All related expenses
Group Re-Lamp after 3000 hours of use	County- All related expenses
Light levels fall below maintained minimum average before 3000 hours of use (Regardless if only one lamp is out)	Manufacturer- All related expenses to bring the light levels above the maintained minimum average

D.03 SUBMITTAL REQUIREMENTS

Each bidder will be required to submit the following items with their bid in order for their bid to be considered responsive:

1. An on field lighting design for each facility as described in **Figure 1** showing the pole height, number of fixtures per pole, luminaire information including wattage, lumens and optics. The designs shall also include a summary table showing the number and spacing of grid points; average, minimum, and maximum illuminance levels in foot-candles (fc); uniformity gradient; number of luminaires, total kilowatts, average tilt factor; light loss factor.

D.03 SUBMITTAL REQUIREMENTS (Continued)

2. An off field lighting design for each facility as described in **Figure 1** showing the capability to adhere to the Outdoor Lighting Regulations from the Manatee County Land Development Code Ordinance 05-37 spill light levels as described in section D.01.B of the bid.
3. A CAD drawing showing pole structural calculations and foundation design showing the foundation shape, depth backfill requirements, rebar and anchor bolts (if required). Pole base reaction forces shall be shown on the foundation drawing along with soil bearing pressures.
4. Written definition and schematics for the flexible control and facility management system of the lighting equipment. If applicable, the quoters shall also provide samples of any system reporting capabilities.
5. Provide written manufacturer's warranty information.

D.04 SITE LOCATIONS

1. Buffalo Creek Park Complex  
7550 69<sup>th</sup> Street East  
Palmetto, FL 34221
2. Braden River Park Complex  
5201 51<sup>st</sup> Street East  
Bradenton, FL 34203
3. Lakewood Ranch Park Complex  
5350 Lakewood Ranch Boulevard  
Bradenton, FL 34202



## BASIS OF AWARD

### E.01 BASIS OF AWARD

Award shall be made on a location by location basis to the most responsive, responsible bidder having the lowest total offer price meeting specifications for each location listed on the Bid Form in the form of a purchase order.

Whenever two or more quotes are equal with respect to price, quality and service, the bid received from a local business shall be given preference in award. Whenever two or more bids which are equal with respect to price, quality and service are received, and both bids or neither of these bids are received from a local business, the award shall be determined by a chance drawing conducted by the Purchasing Office and open to the public.

Local business is defined as a business duly licensed and authorized to engage in the sale of goods and/or services to be procured, which has a place of business in Manatee County with full time employees at that location.

**BID FORM**  
(Submit in Triplicate)

TO: Manatee County Purchasing  
1112 Manatee Avenue West  
Bradenton, Florida 34205

RE: "IFB #09-0485CD- Purchase of Sports Lighting Systems for Various Park's Soccer Fields"

DESCRIPTION	TOTAL PRICE
<b>Buffalo Creek Park- (1) Soccer/Football-</b> Design criteria is a 180 ft x 360 ft soccer/football field, 30 FC design, 4- poles (70 ft min height) in a universal layout (four corners design) setbacks are to be field determined.	\$ _____
<b>Braden River Park- (1) Soccer Field #3-</b> Design criteria is a 180 ft x 360 ft soccer field, 30 FC design, 4- poles (70 ft min height)- setbacks are to be field determined	\$ _____
<b>Lakewood Ranch Park- (2) Soccer Fields-</b> Design criteria are two (2) soccer fields at 220 ft x 360 ft aligned north and south, 30 FC design, 6- poles (70 ft min height) in a universal layout (four corners design) with the fields sharing two poles- setbacks are to be field determined.	\$ _____

We, the undersigned, hereby declare that we have carefully reviewed the bid documents, and with full knowledge and understanding of the aforementioned herewith submit this bid, meeting each and every specification, term and condition contained in this Invitation for Bids.

We understand that the bid specifications, terms and conditions in their entirety shall be made a part of any agreement or contract between Manatee County and the successful bidder. Failure to comply shall result in contract default, whereupon, the defaulting vendor shall be required to pay for any and all re-procurement costs, damages, and attorney fees as incurred by the County.

COMPANY NAME: \_\_\_\_\_

AUTHORIZED SIGNATURE: \_\_\_\_\_

\_\_\_\_\_  
(Print Name & Title of Signer)

DATE: \_\_\_\_\_

COMPANY ADDRESS: \_\_\_\_\_

\_\_\_\_\_

TEL. NO.: \_\_\_\_\_ FAX NO.: \_\_\_\_\_

FEIN NO.: \_\_\_\_\_

Acknowledge Addendum No. \_\_\_\_ Dated: \_\_\_\_\_

Acknowledge Addendum No. \_\_\_\_ Dated: \_\_\_\_\_



Attachment "A"

STATEMENT OF NO BID

If you do not intend to bid please return this form immediately to:

Manatee County Purchasing  
1112 Manatee Avenue West, Suite 803  
Bradenton, Florida 34205

We, the undersigned, have declined to bid on Bid No.: 09-0485CD- Purchase of Sports Lighting Systems for Various Park's Soccer Fields, for the following reason(s):

- Specifications too restrictive, i.e., geared toward one brand or manufacturer.
- Insufficient time to respond
- We do not offer this product or service
- Our schedule would not permit us to perform
- Unable to meet specifications
- Unable to meet Bond requirement
- Specifications unclear (explain below)
- Unable to meet insurance requirements
- Remove us from your "Bidders List"
- Other (specify below)

REMARKS:

We understand that if we do not submit a Bid and this Statement of No Bid is not executed and returned, our name may be deleted from your Bidders List for this commodity or service.

Company Name: \_\_\_\_\_

Company Address: \_\_\_\_\_

Telephone: \_\_\_\_\_

Date: \_\_\_\_\_

Signature: \_\_\_\_\_

\_\_\_\_\_  
(Print or type name and title of above signer)

**ATTACHMENT "B"****Drug Free Work Place Certification**

SWORN STATEMENT PURSUANT TO SECTION 6-101(7)(B),  
MANATEE COUNTY PURCHASING CODE, ON DRUG FREE WORK PLACES

THIS FORM MUST BE SIGNED AND SWORN TO IN THE PRESENCE OF A NOTARY PUBLIC OR OTHER OFFICIAL AUTHORIZED TO ADMINISTER OATHS.

This sworn statement is submitted to the Manatee County Board of County Commissioners by \_\_\_\_\_

[print individual's name and title]

\_\_\_\_\_ for \_\_\_\_\_  
 [print name of entity submitting sworn statement]

whose business address is: \_\_\_\_\_

and (if applicable) its Federal Employer Identification Number (FEIN) is \_\_\_\_\_ (If the entity has no FEIN, include the Social Security Number of the individual signing this sworn statement: \_\_\_\_\_.)

I understand that no person or entity shall be awarded or receive a county contract for public improvements, procurement of goods or services (including professional services) or a county lease, franchise, concession or management agreement, or shall receive a grant of county monies unless such person or entity has submitted a written certification to the County that it will provide a drug free work place by:

(1) providing a written statement to each employee notifying such employee that the unlawful manufacture, distribution, dispensation, possession or use of a controlled substance as defined by '893.02(4), Florida Statutes, as the same may be amended from time to time, in the person's or entity's work place is prohibited specifying the actions that will be taken against employees for violation of such prohibition. Such written statement shall inform employees about:

- (i) the dangers of drug abuse in the work place;
- (ii) the person's or entity's policy of maintaining a drug free environment at all its work places, including but not limited to all locations where employees perform any task relating to any portion of such contract, business transaction or grant;
- (iii) any available drug counseling, rehabilitation, and employee assistance programs; and
- (iv) the penalties that may be imposed upon employees for drug abuse violations.

(2) Requiring the employee to sign a copy of such written statement to acknowledge his or her receipt of same and advice as to the specifics of such policy. Such person or entity shall retain the statements signed by its employees. Such person or entity shall also post in a prominent place at all of its work places a written statement of its policy containing the foregoing elements (i) through (iv).

(3) Notifying the employee in the statement required by subsection (1) that as a condition of employment the employee will:

- (i) abide by the terms of the statement; and
- (ii) notify the employer of any criminal drug statute conviction for a violation occurring in the work place no later than five (5) days after such a conviction.



(4) Notifying the County within ten (10) days after receiving notice under subsection (3) from an employee or otherwise receiving actual notice of such conviction.

(5) Imposing appropriate personnel action against such employee up to and including termination; or requiring such employee to satisfactorily participate in a drug abuse assistance or rehabilitation program approved for such purposes by a federal, state, or local health, law enforcement, or other appropriate agency.

(6) Making a good faith effort to continue to maintain a drug free work place through implementation of sections (1) through (5) stated above.

I UNDERSTAND THAT THE SUBMISSION OF THIS FORM TO THE CONTRACTING OFFICER FOR MANATEE COUNTY IS VALID THROUGH DECEMBER 31 OF THE CALENDAR YEAR IN WHICH IT IS FILED. I ALSO UNDERSTAND THAT ANY CONTRACT OR BUSINESS TRANSACTION SHALL PROVIDE FOR SUSPENSION OF PAYMENTS, OR TERMINATION, OR BOTH, IF THE CONTRACTING OFFICER OR THE COUNTY ADMINISTRATOR DETERMINES THAT:

- (1) Such person or entity has made false certification.
- (2) Such person or entity violates such certification by failing to carry out the requirements of sections (1), (2), (3), (4), (5), or (6) or subsection 3-101(7)(B); or
- (3) Such a number of employees of such person or entity have been convicted of violations occurring in the work place as to indicate that such person or entity has failed to make a good faith effort to provide a drug free work place as required by subsection 3-101(7)(B).

\_\_\_\_\_  
[Signature]

STATE OF FLORIDA  
COUNTY OF \_\_\_\_\_

Sworn to and subscribed before me this \_\_\_\_\_ day of \_\_\_\_\_, 200\_\_ by \_\_\_\_\_.

Personally known \_\_\_\_\_ OR Produced identification \_\_\_\_\_  
[Type of identification]

\_\_\_\_\_  
Notary Public Signature My commission expires \_\_\_\_\_

\_\_\_\_\_  
[Print, type or stamp Commissioned name of Notary Public]

**Attachment "C"**

**PUBLIC CONTRACTING AND ENVIRONMENTAL CRIMES CERTIFICATION**

SWORN STATEMENT PURSUANT TO ARTICLE 6,  
MANATEE COUNTY PURCHASING CODE

THIS FORM MUST BE SIGNED AND SWORN TO IN THE PRESENCE OF A NOTARY PUBLIC OR OTHER OFFICIAL AUTHORIZED TO ADMINISTER OATHS.

This sworn statement is submitted to the Manatee County Board of County Commissioners by \_\_\_\_\_  
[print individual's name and title]

\_\_\_\_\_ for \_\_\_\_\_  
[print name of entity submitting sworn statement]

whose business address is: \_\_\_\_\_

and (if applicable) its Federal Employer Identification Number (FEIN) is \_\_\_\_\_. If the entity has no

FEIN, include the Social Security Number of the individual signing this sworn statement: \_\_\_\_\_

I understand that no person or entity shall be awarded or receive a county contract for public improvements, procurement of goods or services (including professional services) or a county lease, franchise, concession or management agreement, or shall receive a grant of county monies unless such person or entity has submitted a written certification to the County that it has not:

- (1) been convicted of bribery or attempting to bribe a public officer or employee of Manatee County, the State of Florida, or any other public entity, including, but not limited to the Government of the United States, any state, or any local government authority in the United States, in that officer's or employee's official capacity; or
- (2) been convicted of an agreement or collusion among bidders or prospective bidders in restraint of freedom of competition, by agreement to bid a fixed price, or otherwise; or
- (3) been convicted of a violation of an environmental law that, in the sole opinion of the County's Purchasing Director, reflects negatively upon the ability of the person or entity to conduct business in a responsible manner; or
- (4) made an admission of guilt of such conduct described in items (1), (2) or (3) above, which is a matter of record, but has not been prosecuted for such conduct, or has made an admission of guilt of such conduct, which is a matter of record, pursuant to formal prosecution. An admission of guilt shall be construed to include a plea of nolo contendere; or
- (5) where an officer, official, agent or employee of a business entity has been convicted of or has admitted guilt to any of the crimes set forth above on behalf of such and entity and pursuant to the direction or authorization of an official thereof (including the person committing the offense, if he is an official of the business entity), the business shall be chargeable with the conduct herein above set forth. A business entity shall be chargeable with the conduct of an affiliated entity, whether wholly owned, partially owned, or one which has common ownership or a common Board of Directors. For purposes of this Form, business entities are affiliated if, directly or indirectly, one business entity controls or has the power to control another business entity, or if an individual or group of individuals controls or has the power to control both entities. Indicia of control shall include, without limitation, interlocking management or ownership, identity of interests among family members, shared organization of a business entity following the ineligibility of a business entity under this Article, or using substantially the same management, ownership or principles as the ineligible entity.

Any person or entity who claims that this Article is inapplicable to him/her/it because a conviction or judgement has been reversed by a court of competent jurisdiction, shall prove the same with documentation satisfactory to the County's Purchasing Director. Upon presentation of such satisfactory proof, the person or entity shall be allowed to contract with the County.



I UNDERSTAND THAT THE SUBMISSION OF THIS FORM TO THE CONTRACTING OFFICER FOR MANATEE COUNTY IS VALID THROUGH DECEMBER 31 OF THE CALENDAR YEAR IN WHICH IT IS FILED. I ALSO UNDERSTAND THAT ANY CONTRACT OR BUSINESS TRANSACTION SHALL PROVIDE FOR SUSPENSION OF PAYMENTS, OR TERMINATION, OR BOTH, IF THE CONTRACTING OFFICER OR THE COUNTY ADMINISTRATOR DETERMINES THAT **SUCH PERSON OR ENTITY HAS MADE FALSE CERTIFICATION.**

\_\_\_\_\_  
[Signature]

STATE OF FLORIDA  
COUNTY OF \_\_\_\_\_

Sworn to and subscribed before me this \_\_\_\_\_ day of \_\_\_\_\_, 20\_\_\_\_ by \_\_\_\_\_.

Personally known \_\_\_\_\_ OR Produced identification \_\_\_\_\_

\_\_\_\_\_  
[Type of identification]

My commission expires \_\_\_\_\_

\_\_\_\_\_  
Notary Public Signature

\_\_\_\_\_  
[Print, type or stamp Commissioned name of Notary Public]

**Signatory Requirement** - In the case of a business entity other than a partnership or a corporation, this affidavit shall be executed by an authorized agent of the entity. In the case of a partnership, this affidavit shall be executed by the general partner(s). In the case of a corporation, this affidavit shall be executed by the corporate president.

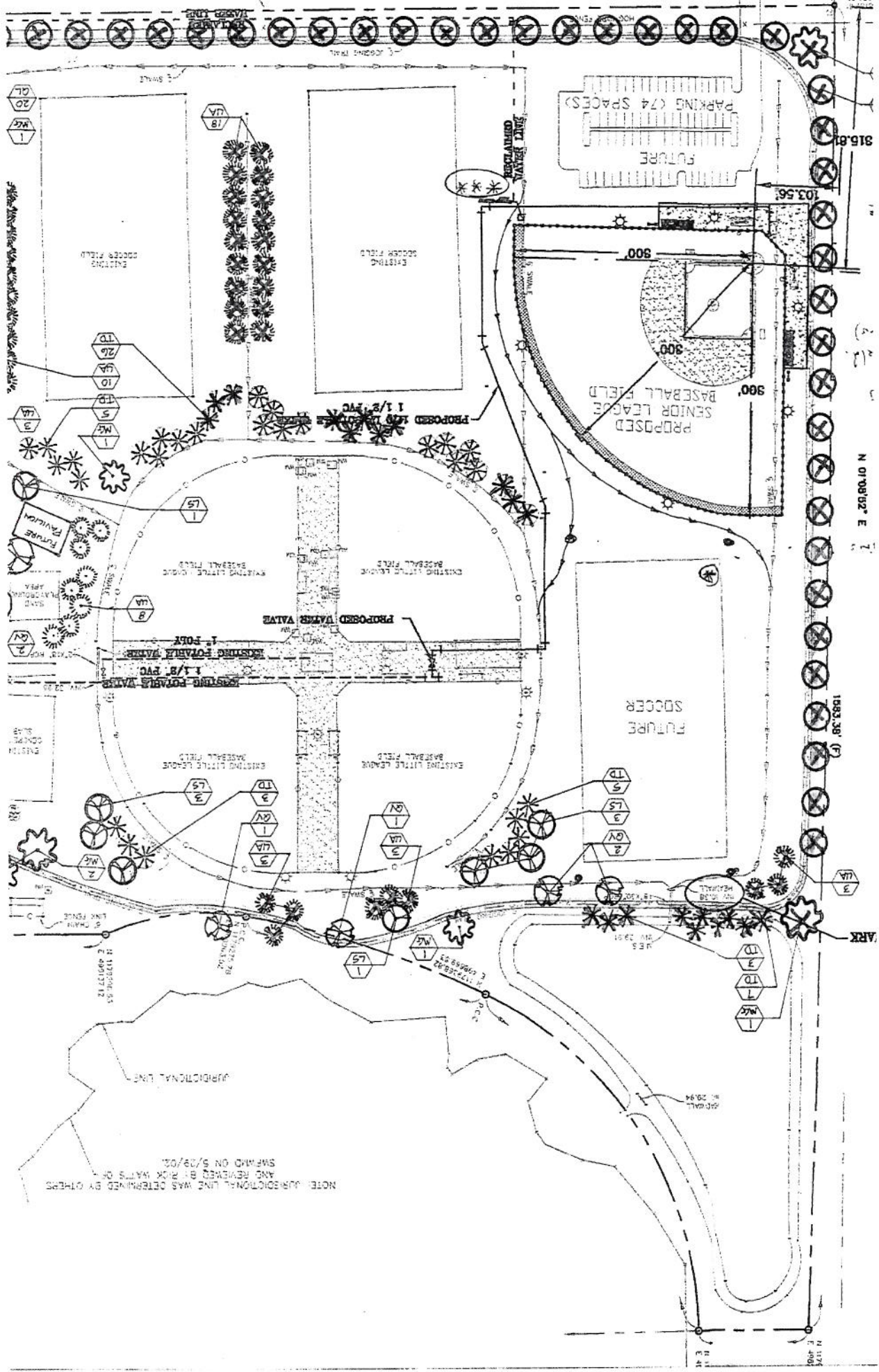

NOTE: JURISDICTIONAL LINE WAS DETERMINED BY OTHERS AND REVERSED BY ROCK WATTS ON 5/29/03.

N 01°09'32" E

1583.38' (P)

ARK

N 117°

E 40'

1.00'

SPOTLIGHT

18.28' 34"

18.28' 34"

18.28' 34"

18.28' 34"

18.28' 34"

18.28' 34"

18.28' 34"

18.28' 34"

18.28' 34"

18.28' 34"

18.28' 34"

18.28' 34"

18.28' 34"

18.28' 34"

18.28' 34"



**PROJECT DATA**  
 PROJECT: BRADEN RIVER PARK  
 CLIENT: MANARTEE COUNTY  
 LOCATION: BRADEN RIVER PARK, MANARTEE COUNTY, NC  
 DATE: 10/15/14  
 DRAWING NO: RSMH-6  
 SHEET NO: 1-1



**LEGAL DESCRIPTION**  
 PARCEL A, PARCEL B, PARCEL C, PARCEL D, PARCEL E, PARCEL F, PARCEL G, PARCEL H, PARCEL I, PARCEL J, PARCEL K, PARCEL L, PARCEL M, PARCEL N, PARCEL O, PARCEL P, PARCEL Q, PARCEL R, PARCEL S, PARCEL T, PARCEL U, PARCEL V, PARCEL W, PARCEL X, PARCEL Y, PARCEL Z, PARCEL AA, PARCEL AB, PARCEL AC, PARCEL AD, PARCEL AE, PARCEL AF, PARCEL AG, PARCEL AH, PARCEL AI, PARCEL AJ, PARCEL AK, PARCEL AL, PARCEL AM, PARCEL AN, PARCEL AO, PARCEL AP, PARCEL AQ, PARCEL AR, PARCEL AS, PARCEL AT, PARCEL AU, PARCEL AV, PARCEL AW, PARCEL AX, PARCEL AY, PARCEL AZ, PARCEL BA, PARCEL BB, PARCEL BC, PARCEL BD, PARCEL BE, PARCEL BF, PARCEL BG, PARCEL BH, PARCEL BI, PARCEL BJ, PARCEL BK, PARCEL BL, PARCEL BM, PARCEL BN, PARCEL BO, PARCEL BP, PARCEL BQ, PARCEL BR, PARCEL BS, PARCEL BT, PARCEL BU, PARCEL BV, PARCEL BW, PARCEL BX, PARCEL BY, PARCEL BZ, PARCEL CA, PARCEL CB, PARCEL CC, PARCEL CD, PARCEL CE, PARCEL CF, PARCEL CG, PARCEL CH, PARCEL CI, PARCEL CJ, PARCEL CK, PARCEL CL, PARCEL CM, PARCEL CN, PARCEL CO, PARCEL CP, PARCEL CQ, PARCEL CR, PARCEL CS, PARCEL CT, PARCEL CU, PARCEL CV, PARCEL CW, PARCEL CX, PARCEL CY, PARCEL CZ, PARCEL DA, PARCEL DB, PARCEL DC, PARCEL DD, PARCEL DE, PARCEL DF, PARCEL DG, PARCEL DH, PARCEL DI, PARCEL DJ, PARCEL DK, PARCEL DL, PARCEL DM, PARCEL DN, PARCEL DO, PARCEL DP, PARCEL DQ, PARCEL DR, PARCEL DS, PARCEL DT, PARCEL DU, PARCEL DV, PARCEL DW, PARCEL DX, PARCEL DY, PARCEL DZ, PARCEL EA, PARCEL EB, PARCEL EC, PARCEL ED, PARCEL EE, PARCEL EF, PARCEL EG, PARCEL EH, PARCEL EI, PARCEL EJ, PARCEL EK, PARCEL EL, PARCEL EM, PARCEL EN, PARCEL EO, PARCEL EP, PARCEL EQ, PARCEL ER, PARCEL ES, PARCEL ET, PARCEL EU, PARCEL EV, PARCEL EW, PARCEL EX, PARCEL EY, PARCEL EZ, PARCEL FA, PARCEL FB, PARCEL FC, PARCEL FD, PARCEL FE, PARCEL FF, PARCEL FG, PARCEL FH, PARCEL FI, PARCEL FJ, PARCEL FK, PARCEL FL, PARCEL FM, PARCEL FN, PARCEL FO, PARCEL FP, PARCEL FQ, PARCEL FR, PARCEL FS, PARCEL FT, PARCEL FU, PARCEL FV, PARCEL FW, PARCEL FX, PARCEL FY, PARCEL FZ, PARCEL GA, PARCEL GB, PARCEL GC, PARCEL GD, PARCEL GE, PARCEL GF, PARCEL GG, PARCEL GH, PARCEL GI, PARCEL GJ, PARCEL GK, PARCEL GL, PARCEL GM, PARCEL GN, PARCEL GO, PARCEL GP, PARCEL GQ, PARCEL GR, PARCEL GS, PARCEL GT, PARCEL GU, PARCEL GV, PARCEL GW, PARCEL GX, PARCEL GY, PARCEL GZ, PARCEL HA, PARCEL HB, PARCEL HC, PARCEL HD, PARCEL HE, PARCEL HF, PARCEL HG, PARCEL HH, PARCEL HI, PARCEL HJ, PARCEL HK, PARCEL HL, PARCEL HM, PARCEL HN, PARCEL HO, PARCEL HP, PARCEL HQ, PARCEL HR, PARCEL HS, PARCEL HT, PARCEL HU, PARCEL HV, PARCEL HW, PARCEL HX, PARCEL HY, PARCEL HZ, PARCEL IA, PARCEL IB, PARCEL IC, PARCEL ID, PARCEL IE, PARCEL IF, PARCEL IG, PARCEL IH, PARCEL II, PARCEL IJ, PARCEL IK, PARCEL IL, PARCEL IM, PARCEL IN, PARCEL IO, PARCEL IP, PARCEL IQ, PARCEL IR, PARCEL IS, PARCEL IT, PARCEL IU, PARCEL IV, PARCEL IW, PARCEL IX, PARCEL IY, PARCEL IZ, PARCEL JA, PARCEL JB, PARCEL JC, PARCEL JD, PARCEL JE, PARCEL JF, PARCEL JG, PARCEL JH, PARCEL JI, PARCEL JJ, PARCEL JK, PARCEL JL, PARCEL JM, PARCEL JN, PARCEL JO, PARCEL JP, PARCEL JQ, PARCEL JR, PARCEL JS, PARCEL JT, PARCEL JU, PARCEL JV, PARCEL JW, PARCEL JX, PARCEL JY, PARCEL JZ, PARCEL KA, PARCEL KB, PARCEL KC, PARCEL KD, PARCEL KE, PARCEL KF, PARCEL KG, PARCEL KH, PARCEL KI, PARCEL KJ, PARCEL KK, PARCEL KL, PARCEL KM, PARCEL KN, PARCEL KO, PARCEL KP, PARCEL KQ, PARCEL KR, PARCEL KS, PARCEL KT, PARCEL KU, PARCEL KV, PARCEL KW, PARCEL KX, PARCEL KY, PARCEL KZ, PARCEL LA, PARCEL LB, PARCEL LC, PARCEL LD, PARCEL LE, PARCEL LF, PARCEL LG, PARCEL LH, PARCEL LI, PARCEL LJ, PARCEL LK, PARCEL LL, PARCEL LM, PARCEL LN, PARCEL LO, PARCEL LP, PARCEL LQ, PARCEL LR, PARCEL LS, PARCEL LT, PARCEL LU, PARCEL LV, PARCEL LW, PARCEL LX, PARCEL LY, PARCEL LZ, PARCEL MA, PARCEL MB, PARCEL MC, PARCEL MD, PARCEL ME, PARCEL MF, PARCEL MG, PARCEL MH, PARCEL MI, PARCEL MJ, PARCEL MK, PARCEL ML, PARCEL MM, PARCEL MN, PARCEL MO, PARCEL MP, PARCEL MQ, PARCEL MR, PARCEL MS, PARCEL MT, PARCEL MU, PARCEL MV, PARCEL MW, PARCEL MX, PARCEL MY, PARCEL MZ, PARCEL NA, PARCEL NB, PARCEL NC, PARCEL ND, PARCEL NE, PARCEL NF, PARCEL NG, PARCEL NH, PARCEL NI, PARCEL NJ, PARCEL NK, PARCEL NL, PARCEL NM, PARCEL NN, PARCEL NO, PARCEL NP, PARCEL NQ, PARCEL NR, PARCEL NS, PARCEL NT, PARCEL NU, PARCEL NV, PARCEL NW, PARCEL NX, PARCEL NY, PARCEL NZ, PARCEL OA, PARCEL OB, PARCEL OC, PARCEL OD, PARCEL OE, PARCEL OF, PARCEL OG, PARCEL OH, PARCEL OI, PARCEL OJ, PARCEL OK, PARCEL OL, PARCEL OM, PARCEL ON, PARCEL OO, PARCEL OP, PARCEL OQ, PARCEL OR, PARCEL OS, PARCEL OT, PARCEL OU, PARCEL OV, PARCEL OW, PARCEL OX, PARCEL OY, PARCEL OZ, PARCEL PA, PARCEL PB, PARCEL PC, PARCEL PD, PARCEL PE, PARCEL PF, PARCEL PG, PARCEL PH, PARCEL PI, PARCEL PJ, PARCEL PK, PARCEL PL, PARCEL PM, PARCEL PN, PARCEL PO, PARCEL PP, PARCEL PQ, PARCEL PR, PARCEL PS, PARCEL PT, PARCEL PU, PARCEL PV, PARCEL PW, PARCEL PX, PARCEL PY, PARCEL PZ, PARCEL QA, PARCEL QB, PARCEL QC, PARCEL QD, PARCEL QE, PARCEL QF, PARCEL QG, PARCEL QH, PARCEL QI, PARCEL QJ, PARCEL QK, PARCEL QL, PARCEL QM, PARCEL QN, PARCEL QO, PARCEL QP, PARCEL QQ, PARCEL QR, PARCEL QS, PARCEL QT, PARCEL QU, PARCEL QV, PARCEL QW, PARCEL QX, PARCEL QY, PARCEL QZ, PARCEL RA, PARCEL RB, PARCEL RC, PARCEL RD, PARCEL RE, PARCEL RF, PARCEL RG, PARCEL RH, PARCEL RI, PARCEL RJ, PARCEL RK, PARCEL RL, PARCEL RM, PARCEL RN, PARCEL RO, PARCEL RP, PARCEL RQ, PARCEL RR, PARCEL RS, PARCEL RT, PARCEL RU, PARCEL RV, PARCEL RW, PARCEL RX, PARCEL RY, PARCEL RZ, PARCEL SA, PARCEL SB, PARCEL SC, PARCEL SD, PARCEL SE, PARCEL SF, PARCEL SG, PARCEL SH, PARCEL SI, PARCEL SJ, PARCEL SK, PARCEL SL, PARCEL SM, PARCEL SN, PARCEL SO, PARCEL SP, PARCEL SQ, PARCEL SR, PARCEL SS, PARCEL ST, PARCEL SU, PARCEL SV, PARCEL SW, PARCEL SX, PARCEL SY, PARCEL SZ, PARCEL TA, PARCEL TB, PARCEL TC, PARCEL TD, PARCEL TE, PARCEL TF, PARCEL TG, PARCEL TH, PARCEL TI, PARCEL TJ, PARCEL TK, PARCEL TL, PARCEL TM, PARCEL TN, PARCEL TO, PARCEL TP, PARCEL TQ, PARCEL TR, PARCEL TS, PARCEL TT, PARCEL TU, PARCEL TV, PARCEL TW, PARCEL TX, PARCEL TY, PARCEL TZ, PARCEL UA, PARCEL UB, PARCEL UC, PARCEL UD, PARCEL UE, PARCEL UF, PARCEL UG, PARCEL UH, PARCEL UI, PARCEL UJ, PARCEL UK, PARCEL UL, PARCEL UM, PARCEL UN, PARCEL UO, PARCEL UP, PARCEL UQ, PARCEL UR, PARCEL US, PARCEL UT, PARCEL UY, PARCEL UZ, PARCEL VA, PARCEL VB, PARCEL VC, PARCEL VD, PARCEL VE, PARCEL VF, PARCEL VG, PARCEL VH, PARCEL VI, PARCEL VJ, PARCEL VK, PARCEL VL, PARCEL VM, PARCEL VN, PARCEL VO, PARCEL VP, PARCEL VQ, PARCEL VR, PARCEL VS, PARCEL VT, PARCEL VU, PARCEL VV, PARCEL VW, PARCEL VX, PARCEL VY, PARCEL VZ, PARCEL WA, PARCEL WB, PARCEL WC, PARCEL WD, PARCEL WE, PARCEL WF, PARCEL WG, PARCEL WH, PARCEL WI, PARCEL WJ, PARCEL WK, PARCEL WL, PARCEL WM, PARCEL WN, PARCEL WO, PARCEL WP, PARCEL WQ, PARCEL WR, PARCEL WS, PARCEL WT, PARCEL WU, PARCEL WV, PARCEL WW, PARCEL WX, PARCEL WY, PARCEL WZ, PARCEL XA, PARCEL XB, PARCEL XC, PARCEL XD, PARCEL XE, PARCEL XF, PARCEL XG, PARCEL XH, PARCEL XI, PARCEL XJ, PARCEL XK, PARCEL XL, PARCEL XM, PARCEL XN, PARCEL XO, PARCEL XP, PARCEL XQ, PARCEL XR, PARCEL XS, PARCEL XT, PARCEL XU, PARCEL XV, PARCEL XW, PARCEL XX, PARCEL XY, PARCEL XZ, PARCEL YA, PARCEL YB, PARCEL YC, PARCEL YD, PARCEL YE, PARCEL YF, PARCEL YG, PARCEL YH, PARCEL YI, PARCEL YJ, PARCEL YK, PARCEL YL, PARCEL YM, PARCEL YN, PARCEL YO, PARCEL YP, PARCEL YQ, PARCEL YR, PARCEL YS, PARCEL YT, PARCEL YU, PARCEL YV, PARCEL YW, PARCEL YX, PARCEL YY, PARCEL YZ, PARCEL ZA, PARCEL ZB, PARCEL ZC, PARCEL ZD, PARCEL ZE, PARCEL ZF, PARCEL ZG, PARCEL ZH, PARCEL ZI, PARCEL ZJ, PARCEL ZK, PARCEL ZL, PARCEL ZM, PARCEL ZN, PARCEL ZO, PARCEL ZP, PARCEL ZQ, PARCEL ZR, PARCEL ZS, PARCEL ZT, PARCEL ZU, PARCEL ZV, PARCEL ZW, PARCEL ZX, PARCEL ZY, PARCEL ZZ

**SITE DATA**  
 TOTAL AREA: 1,234,567 SQ. FT.  
 TOTAL ACRES: 28.3  
 ZONING: PD-MU/CH  
 PERMITTED USES: COMMERCIAL, OFFICE, PROFESSIONAL, PUBLIC USE, RETAIL, SERVICE, SPECIAL USE, USES NOT SPECIFICALLY LISTED IN THE ZONING ORDINANCE.  
 PROHIBITED USES: MANUFACTURING, INDUSTRIAL, STORAGE, USES NOT SPECIFICALLY LISTED IN THE ZONING ORDINANCE.  
 SETBACKS: 10 FT. FRONT, 10 FT. SIDE, 10 FT. REAR.  
 HEIGHT: 35 FT. MAXIMUM.  
 SIGNAGE: PERMITTED AS SHOWN ON THE SITE PLAN.  
 UTILITIES: ALL UTILITIES TO BE DELETED OR RELOCATED AS SHOWN ON THE SITE PLAN.  
 EROSION CONTROL: EROSION CONTROL MEASURES TO BE INSTALLED AS SHOWN ON THE SITE PLAN.  
 TRAFFIC: TRAFFIC IMPROVEMENTS TO BE INSTALLED AS SHOWN ON THE SITE PLAN.  
 LANDSCAPE: LANDSCAPE ARCHITECTURE TO BE INSTALLED AS SHOWN ON THE SITE PLAN.  
 LIGHTING: LIGHTING TO BE INSTALLED AS SHOWN ON THE SITE PLAN.  
 SECURITY: SECURITY MEASURES TO BE INSTALLED AS SHOWN ON THE SITE PLAN.  
 OTHER: OTHER REQUIREMENTS TO BE INSTALLED AS SHOWN ON THE SITE PLAN.

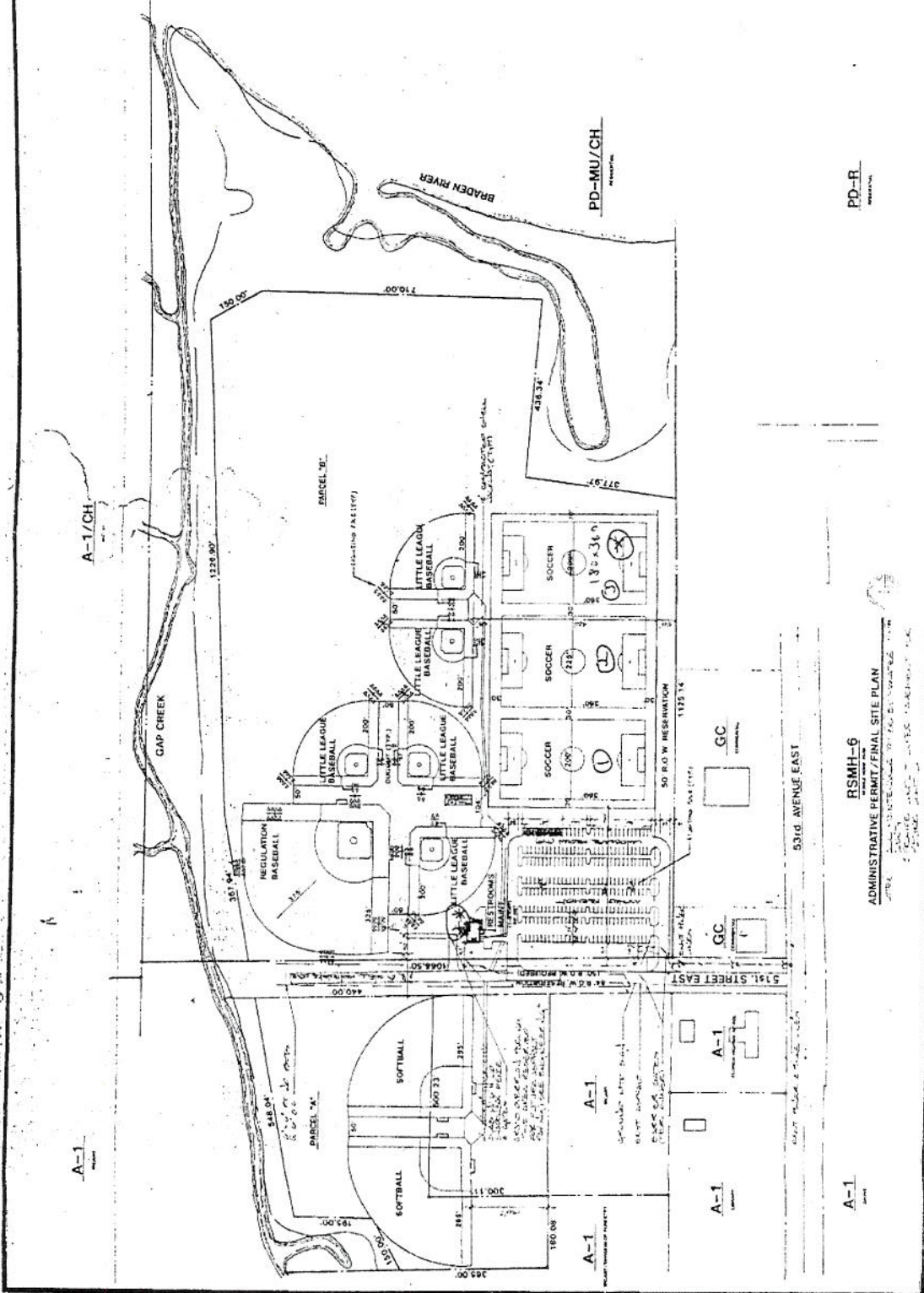

**RSMH-6**  
 ADMINISTRATIVE PERMIT/FINAL SITE PLAN  
 JERRY M. ZOLLER ARCHITECT / PLANNER P.A.  
 1515 15th STREET W. BRANTFORD, ONT. L6A 3K9  
 DATE: 10/15/14

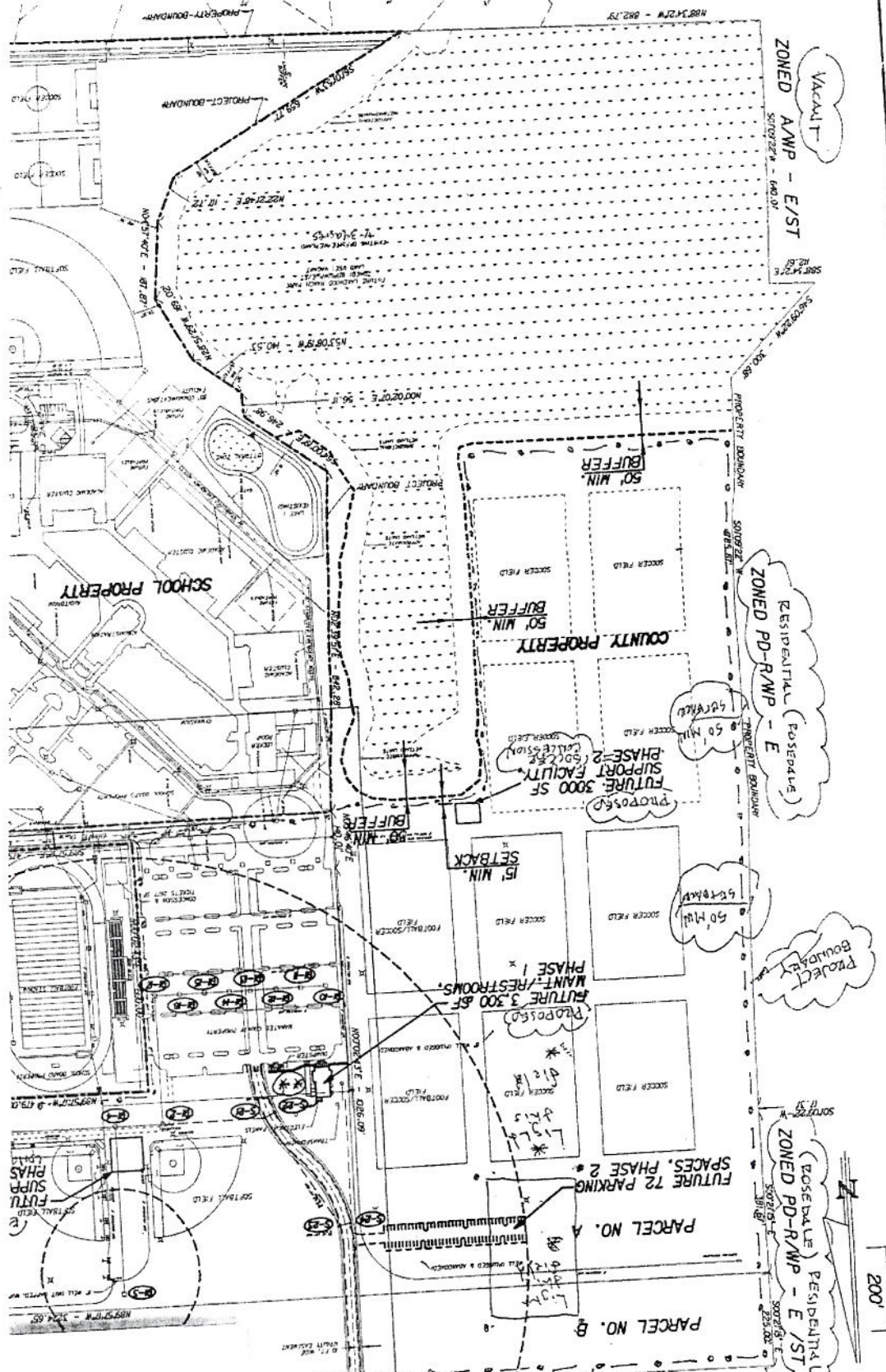

\*Assess Mineral Holdings  
 Layout for a new drill  
 site on stem poles

Field size 220' x 360'



# Regulations – Land Development Code Excerpts

## Outdoor Lighting

Manatee County, Florida

Selected content from Ordinance 05-37

Adopted September 20, 2005 by the Manatee County Board of County Commissioners

Manatee County Land Development Code

Excerpts related to outdoor lighting

## Table of Contents

<b>Definitions</b> .....	3
<i>Fixture</i> .....	3
<i>Footcandle</i> .....	3
<i>Full horizontal shielding</i> .....	3
<i>Full oblique shielding</i> .....	4
<i>Light source</i> .....	4
<i>Lumen</i> .....	4
<i>Protected area</i> .....	5
<i>Shield</i> .....	5
<i>Shielding Angle</i> .....	5
<b>Amendments to Official Zoning Atlas</b> .....	6
<i>Factors for Reviewing Proposed Amendments</i> .....	6
<b>Site Plans</b> .....	7
<i>Final Site Plan Requirements</i> .....	7
<b>Lighting</b> .....	7
<i>Intent</i> .....	7
<i>Applicability</i> .....	7
<i>Exemptions</i> .....	7
<i>Low Intensity</i> .....	7
<i>Streets</i> .....	7
<i>Emergency</i> .....	8
<i>Construction</i> .....	8
<i>Road and Utility Repairs</i> .....	8
<i>Signs</i> .....	8
<i>Religious or National Symbols and Flags</i> .....	8
<i>Underwater Lamps</i> .....	8
<i>Safety</i> .....	8
<i>Illumination Limits</i> .....	8
<i>Direct Illumination</i> .....	8
<i>Driver Vision Impairment</i> .....	9
<i>Measurable Spill Illumination Limits</i> .....	9
<i>Fixture Height</i> .....	9
<i>Controllers, Timers and Sensors</i> .....	9
<i>Special Lights</i> .....	9
<i>Aerial Lights</i> .....	9
<i>Accent Lights</i> .....	10
<i>Boat Dock &amp; Marina Lights</i> .....	10
<i>Canopy Lights</i> .....	10
<i>Fascia Lights</i> .....	10
<i>Gas Pump, Convenience Business, Automatic Teller Machine, and other Required Security Lights</i> .....	10
<i>Outline Lights</i> .....	10
<i>Projection Lights</i> .....	10
<i>Required Lights</i> .....	10
<i>Stadium and Recreation Lights</i> .....	10
<i>Lighting Plan</i> .....	11
<i>Submittal</i> .....	11
<i>Fixture Locations</i> .....	11
<i>Fixture Detail</i> .....	11
<i>Fixture Height and Mounts</i> .....	11
<i>Direct Illumination Plots</i> .....	11
<i>Photometric Diagram</i> .....	12
<i>Review</i> .....	12
<i>Inspection</i> .....	13



**Section 201. Definitions.**

*Lighting, Outdoor.* (See "OUTDOOR LIGHTING.")

*Lumen (Outdoor Lighting).* (See "OUTDOOR LIGHTING.")

**OUTDOOR LIGHTING.**

*Fixture (Outdoor Lighting).* The light source, the lamp holder, the shields, and their housing in an assembly that may include other components, e.g., electrical devices. Including but not limited to: security, flood, spot, wall, fascia, back, advertising, landscape, foot path, accent, outline, swivel, directional, movable, portable, yard, seawall, or dock light.

*Footcandle (Outdoor Lighting).* The unit for measurement of illumination received by a surface located at a distance from a source of visible light. Typically calculated for a lighting plan and measured with a light meter.

*Full horizontal shielding (Outdoor Lighting).* A design for a fixture that does not emit light above the horizontal plane running through the lowest point on the light source. Does not include a drop lens, sag lens, or convex lens if the lens extends below the shield. Sometimes called *fully shielded* by manufacturers of outdoor lighting. The following illustrations provide examples:

The bulb, reflectors, or lens do not extend below the shield:

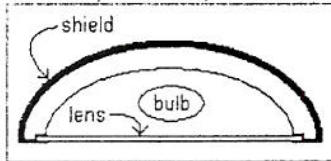

Vertical cross section of fixture with *full horizontal shielding*

The illumination does not project above the fixture:



Street lighting from fixture with *full horizontal shielding*

*Full oblique shielding (Outdoor Lighting).* A design for a fixture that does not emit light above the line of sight to the light source when viewed from protected property. The shield blocks direct illumination of protected property. The fixture completely conceals and recesses the light source from all viewing positions except those positions permitted to receive illumination. The following illustrations provide examples:

The interior surface of the shield below the lens has a dull and dark finish to prevent reflection of light.

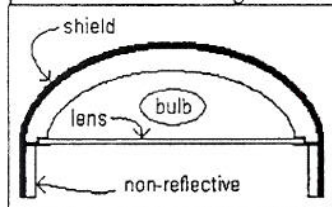

Vertical cross section of fixture with *full oblique shielding*

The illumination does not project into protected property:

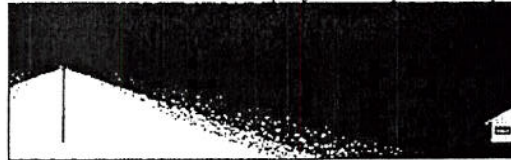

Area lighting from fixture with *full oblique shielding*

Observations along the sight line to an installed fixture can determine if the fixture has full oblique shielding. Sight lines exist along the oblique boundary between the illumination cone and the shielded area above it.



Sight line between observer and light source

An observer can establish a sight line at any location where the observer can see only a small part of the fixture's light source. By moving away from the fixture until the light source no longer appears, the observer will cross the sight line. Where the observer's eyes coincide with the sight line, the observer can project the sight line to the ground. The sight line coincides with the oblique line along the bottom of the shielding angle (see definition). If the sight line falls on protected property, then the fixture does not provide adequate full oblique shielding.

*Light source (Outdoor Lighting).* The medium producing the visible light or changing the direction of the light. Such media may include bulbs, lenses, refractors, reflectors, diffusers, or any emitter of visible light either directly from the material discharging the visible radiant energy or indirectly from material that redirects the illuminating light.

*Lumen (Outdoor Lighting).* The unit of measurement of the total visible light produced by a light source. Typically published in specifications by the manufacturer.



*Protected area (Outdoor Lighting).* An area intended for protection from outdoor lighting including any property: 1) in residential use, 2) in a residential zoning district that may develop into a residential use, 3) in a planned development zoning district that may develop into a residential use, or 4) in a public street right-of-way.

*Shield (Outdoor Lighting).* The opaque barrier on the fixture to block the light from illuminating certain distant surfaces. No light escapes through a shield.

*Shielding Angle (Outdoor Lighting).* The opaque angle shielded below the horizontal plane that runs through the bottom of the light source in a fixture with full oblique shielding. The oblique line along the bottom of the angle coincides with the sight line (see definition of full oblique shielding) along the oblique boundary between the illumination cone and the shielded area above it. Lighting plans use the shielding angles in calculations to plot projections of the sight lines onto land areas. Manufacturers of fixtures can provide specifications with shielding angles or diagrams showing vertical cross sections of the fixtures. Also, direct measurements of actual fixtures can determine shielding angles. Shielding angle and sample light ray paths in vertical cross sections of fixtures appear in the following illustrations showing examples of how to determine a shielding angle:

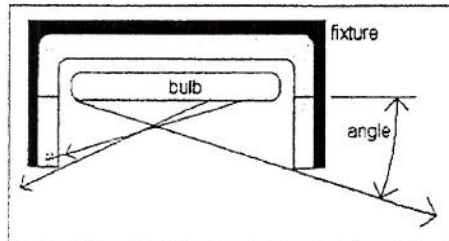

**Simple shield blocking light rays above and around sides**

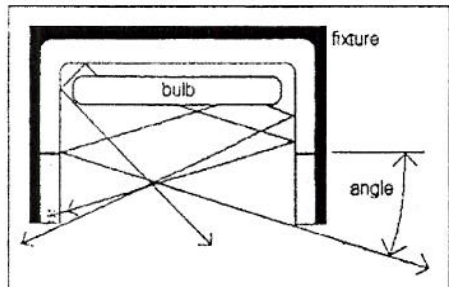

**Reflectors redirecting light rays. Shield around bottom does not reflect**

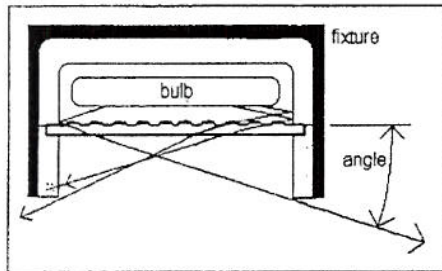

Lens diffusing or refracting, i.e., changing direction of light rays

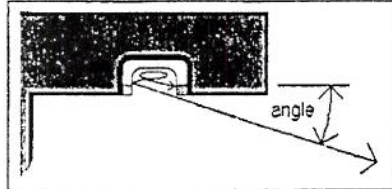

Soffit shielding with recessed fixture

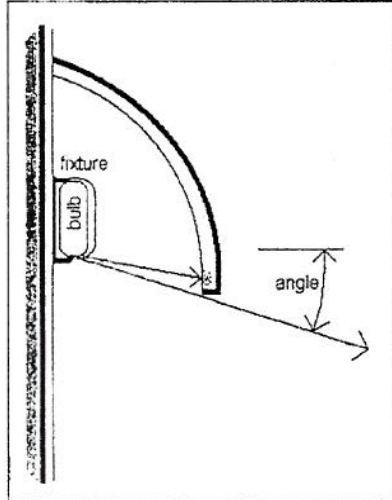

Opaque fabric canopy or fixed-awning shielding a hidden fixture

Section 540. Amendments to Official Zoning Atlas.

504.5. *Factors for Reviewing Proposed Amendments.* In deciding whether to recommend approval of a proposed amendment, or in deciding whether to adopt a proposed amendment, the Planning Director, Planning Commission and the Board shall consider whether the proposed amendment is consistent with the Comprehensive Plan. In particular, the Planning Director, the Planning Commission and the Board shall consider the following factors:

- 13. Will the proposed change allow uses that require so much outdoor lighting that even the light from shielded fixtures may reflect off-site with potentially adverse



effects on residential areas?

...  
**Section 508. Site Plans.**  
...

508.3.4. *Final Site Plan Requirements.* All Final Site Plans required by this Code shall be submitted in the number of copies required by the Planning Director, together with the required fee established by the Board. Such plans shall include the following information:

5. *Site Design*  
...

- g. Plans for outdoor lighting pursuant to Section 709 and signs, if any, including the location, type, height, and area.

...  
**Section 709. Lighting**

709.1. *Intent.* These outdoor lighting regulations intend to protect people and property values from the nuisance and harm of excessive outdoor lighting that:

Hinders or decreases visibility.

Glares into the eyes of drivers looking for safe nighttime visibility.

Creates a blinding brightness that leaves high-contrast, unsafely dark, shadowed areas.

Creates an artificial atmospheric glow that prevents residents from enjoying the night sky around their homes.

Spills into the yards, homes and streets of neighborhoods trying to maintain a visually calm residential character.

709.2. *Applicability.* Unless exempted in Section 709.3 *Exemptions*, these lighting regulations apply to and require a Lighting Plan for:

709.2.1. Development and redevelopment of nonresidential projects, multi-family dwelling residential projects, and common improvements in other residential projects, e.g., recreational facilities.

709.2.2. Outdoor lighting fixtures added to or intensified in nonresidential projects, multifamily projects, and common improvements in single-family residential projects, e.g., vehicle use areas and recreational facilities. Routine maintenance, e.g., cleaning and changing bulbs, ballast, starter, housing, lenses and other similar components, shall not constitute intensification provided such changes do not result in a higher lumen output compared to the fixture when new, i.e., a light brighter than the intensity of the original installation as determined by the lumen rating printed on the bulb, the shipping package, or the specification sheet.

709.3. *Exemptions:*

709.3.1. *Low Intensity* Lighting to safely illuminate street address numbers, residential building entries, residential driveways, and residential yards with light sources rated less than 800 lumens or with fixtures shielded to block direct illumination beyond these areas.

709.3.2. *Streets* Lighting to safely illuminate streets, including but not limited to their driving lanes, sidewalks, roadside recovery shoulders, and emergency lanes. Such fixtures shall have full horizontal shielding to prevent direct illumination above the

fixture and to minimize direct illumination of residences nearby.

709.3.3. *Emergency* Lighting for emergency safety repairs or natural disaster recovery.

709.3.4. *Construction* Lighting for building or site construction not exceeding ten days during any consecutive twelve months.

709.3.5. *Road and Utility Repairs* Lighting for construction, renovation, or repair of roads and utilities.

709.3.6. *Signs* Lighting for signs permitted by this Land Development Code, under the following conditions:

- a. Externally illuminated signs shall have full oblique shielding aiming the light down onto the sign.
- b. Internally illuminated signs shall comply with the Driver Vision Impairment requirements of this Section unless the signs serve only to provide driver directions without interfering with safe driver vision or traffic controls.
- c. The light from a sign shall not exceed the Measurable Spill Illumination Limits of this Section or violate the Driver Vision Impairment requirements of this Section.
- d. The extensive illuminated area of the background shall count toward the maximum sign area permitted by sign regulations.

709.3.7. *Religious or National Symbols and Flags* Lighting for religious or national symbols and flags permitted by this Land Development Code, under the following conditions:

- a. Symbols and flags that need illumination should have full oblique shielding but may have spot lights aimed up only to illuminate the symbol or flag.
- b. Internally illuminated symbols shall comply with the Driver Vision Impairment requirements of this Section.
- c. The light for a symbol or flag shall not exceed the Measurable Spill Illumination Limits of this Section or violate the Driver Vision Impairment requirements of this Section.

709.3.8. *Underwater Lamps* Underwater lamps in swimming pools and other water bodies for safety.

709.3.9. *Safety* Lighting required by government law for safety as follows:

- a. Lamps for exit signs, traffic control, waterway navigation, and aviation navigation shall have no restriction.
- b. Lamps for ramps, stairs, handicap access, boat dock decks, and other safety purposes shall have fully shielded fixtures aiming the light down onto the area requiring illumination by law.

#### 709.4. *Illumination Limits*

709.4.1. *Direct Illumination* Unless otherwise exempted in Section 709.3, all outdoor



lighting fixtures shall have full oblique shielding so that a property's light sources do not directly illuminate another property that has an outdoor lighting protected area.

709.4.2. *Driver Vision Impairment* Lights shall not impair the vision of drivers and interfere with safe driving. A light source shall have shields to prevent it from glaring into the eyes of drivers where drivers need to see structures, signs, other vehicles, and overhead clearances to a height of sixteen (16) feet. Affected driving areas include streets, driveways, parking lots, and other vehicle use areas on-site or off-site.

709.4.3. *Measurable Spill Illumination Limits* The total illumination caused by all of a property's outdoor lighting, including light sources, diffraction, and reflections from on-site objects, shall not illuminate another property in excess of the following limits:

- a. 0.2 foot-candles on property with outdoor lighting protected areas but not including the street rights-of-way.
- b. 1.5 foot-candles on street rights-of-way because such limited coincidental illumination of a street will not constitute a nuisance to people using the street.

#### 709.5. *Fixture Height*

709.5.1. Fixture height, measured from finished grade at ground level to the bottom of the light source, determines the vertical point from which the light projects downward. Regardless of height limits, below, prevention of spill illumination may require lower heights according to calculations and plots in the Lighting Plan.

##### 709.5.2. *Limits*

709.5.2.1. All light fixtures located within 50 feet of any another property that has an outdoor lighting protected area shall not exceed 16 feet in height.

709.5.2.2. All light fixtures located within 100 feet of any another property that has an outdoor lighting protected area shall not exceed 20 feet in height.

709.5.2.3. All other light fixtures elsewhere shall not exceed 30 feet in height.

#### 709.6. *Controllers, Timers and Sensors*

709.6.1. Lights shall not illuminate when not needed. Unnecessary light constitutes a nuisance and a harm that timers, light sensors, switches, motion detectors, and occupancy sensors may prevent.

709.6.2. All electrical circuits for outdoor lighting shall have manually controlled switches conveniently located for manual operation.

709.6.3. Light sensors shall automatically turn off lights when they sense adequate daylight.

709.6.4. Timers shall automatically turn off and turn on lights when their clocks arrive at pre-set times corresponding to the times needing the lights. Alternatively, the controller may dim lights or allow fewer lights to remain on for security and safety. Motion detectors and occupancy sensors may interrupt to turn on lights for timed durations.

#### 709.7. *Special Lights*

709.7.1. *Aerial Lights* No fixture shall aim light upward to search, sweep, or move through the sky.

709.7.2. *Accent Lights* Light used to accent architectural features, fascia, landscaping, art, or similar objects shall not directly illuminate outdoor lighting protected areas. All such light shall terminate on opaque surfaces within the property.

709.7.3. *Boat Dock & Marina Lights*

709.7.3.1. All lighting for boat docks and marinas, public or private, shall provide shields to prevent spill illumination beyond the property and beyond the permitted boat docking and turning areas.

709.7.3.2. If required by government law for safe navigation, then red and green navigation lights may mark channels in the waterways.

709.7.3.3. If required by government law for safety, then lamps for boat dock decks shall have fully shielded fixtures aiming the light down onto the area requiring illumination by law.

709.7.4. *Canopy Lights* An opaque canopy, soffit, or overhang may serve as the required horizontal cut off and fixture shielding for lights fully recessed into the underside of the canopy. Such shielding shall appear as part of the Fixture Detail required on a Lighting Plan.

709.7.5. *Fascia Lights* Fascia on a canopy shall not include fixtures for outdoor lighting of the site or buildings. A sign on the fascia may include lights to illuminate the sign, but the illuminated area of the fascia shall count toward the maximum sign area permitted by sign regulations.

709.7.6. *Gas Pump, Convenience Business, Automatic Teller Machine, and other Required Security Lights* Whenever state or federal law requires certain intense illumination levels for security, then the location, intensity, quantity, height, shielding, and aim of such lights shall satisfy such requirement while still complying with these regulations, e.g., preventing direct illumination off-site, to the maximum extent possible.

709.7.7. *Outline Lights* Illuminated tubing, strings of lights, back-lighted objects, or similar fixtures that outline structures, sales areas, roofs, doors, windows, plants, or similar areas shall not light upward.

709.7.8. *Projection Lights* All projected light, laser or otherwise, shall terminate on an opaque surface.

709.7.9. *Required Lights* Whenever state or federal law requires certain illumination, e.g., safe access, then the location, intensity, quantity, height, shielding, and aim of such lights shall satisfy such requirements while still complying with these regulations, e.g., preventing direct illumination off-site, to the maximum extent possible.

709.7.10. *Stadium and Recreation Lights*

709.7.10.1. Whenever players in sporting events and recreational activities require certain intense illumination levels for safety, then the location, intensity, quantity, height, shielding, and aim of such lights shall satisfy such requirement while still complying with these regulations, e.g., preventing direct illumination off-site, to the maximum extent possible.

709.7.10.2. The illumination of outdoor recreational activities shall stop at 11:00 PM for the remainder of the night. An activity should not begin earlier if it will normally exceed this time limit. Regardless, an activity already in progress from



an earlier starting time may continue with illumination until no later than 11:30 PM. Other lower level illumination may remain for safe spectator departure and security.

#### 709.8. Lighting Plan

709.8.1. *Purpose* A lighting plan shall serve to prevent excessive lighting prior to installation of the fixtures and to avoid costly compliance remedies later.

709.8.2. *Submittal* A Lighting Plan shall accompany all applications for Final Site Plan approval of development and redevelopment of nonresidential projects, multi-family dwelling residential projects, and common improvements in other residential projects, e.g., recreational facilities. When these regulations require a Lighting Plan but the project does not require a Final Site Plan, then the plan shall accompany the application for a Building Permit for electrical fixtures. Lighting Plans shall provide enough information to determine the potential for direct illumination of outdoor lighting protected areas, spill illumination, and compliance with this Section for all lighting not exempted in Section 709.3.

709.8.3. *Fixture Locations* A lighting plan shall show the horizontal position of the fixtures on the site.

709.8.4. *Fixture Detail* An inset drawing of a typical fixture shall show the directional controls, e.g., shields, reflectors, refractors, and lenses, that will aim and limit the angle of illumination. The detail shall show the vertical angle of illumination that will determine the shielding angle.

709.8.5. *Fixture Height and Mounts* The plan shall show the height of the fixtures and describe the mounts, e.g., wall, pole, or canopy.

709.8.6. *Direct Illumination Plots* For each and every fixture, the lighting plan shall use the fixture shielding angle and fixture height in calculations to plot the edge of the projection of the expected direct illumination onto the areas, both on-site and off-site, shown on the plan. The calculations and horizontal plots for each and every fixture shall appear on the plan. The horizontal plotting shall result from the following calculations based on the following illustration:

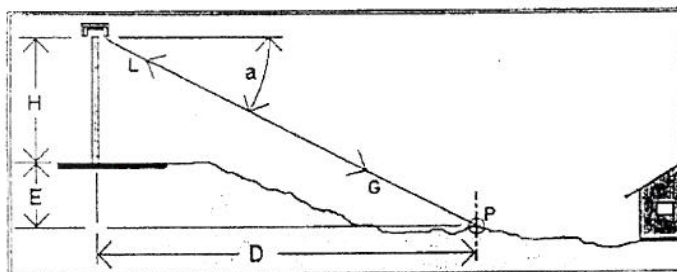

Cross section in the vertical plane through a light fixture, pole, and grade

Legend for symbols in illustration and calculation:

- a shielding angle of fixture
- LG line along the oblique boundary between the illumination cone and the shielded area above it, i.e., also the sight line between the light

- source and ground level at the edge of direct illumination
- P projection of the line LG onto the ground level, i.e., also the edge of direct illumination
- D distance horizontally from light source to P
- H height vertically from ground to bottom of light source
- E elevation difference vertically between ground level below light source and ground level at P
- / divided by
- tan trigonometric tangent function

Calculation of the distance to the edge of direct illumination:

$$D = (H + E) / \tan a$$

#### 709.8.7. *Photometric Diagram*

709.8.7.1. Any of the following conditions require that the Lighting Plan shall also include a Photometric Diagram:

- a. A projection of direct illumination within 10 horizontal feet of the property line of outdoor lighting protected areas or a street.
- b. A fixture within 80 horizontal feet of the property line of outdoor lighting protected areas or a street.
- c. A fixture higher than 20 feet above ground level within 600 horizontal feet of the property line of outdoor lighting protected areas.

709.8.7.2. A lighting engineer shall prepare the diagram.

709.8.7.3. The diagram shall plot foot-candles of illumination calculated:

- a. For the direction of the most illumination from the light sources;
- b. For a height of five (5) feet above ground level;
- c. To the nearest tenth (0.1) foot-candle; and
- d. At horizontal grid intervals of ten (10) feet.

709.8.7.4. The diagram shall cover a certain part of the affected street or property having the outdoor lighting protected area. Such part shall include the area within the circle formed with the light fixture at the center and the radius extending one hundred (100) feet into the affected street right-of-way or property of the protected area.

709.8.7.5. The plotted levels of calculated illumination shall determine if the lighting will comply with the Measurable Spill Illumination Limits of this Section.

#### 709.9. *Review*

709.9.1. The Planning Department of Manatee County shall review the Lighting Plan and determine compliance with this Section..



709.10. *Inspection*

709.10.1. The Planning Department of Manatee County shall inspect the installed lighting fixtures and determine compliance with this Section and the approved Lighting Plan.